

(19) World Intellectual Property Organization
International Bureau



(43) International Publication Date
31 January 2002 (31.01.2002)

PCT

(10) International Publication Number
WO 02/07653 A1

- (51) International Patent Classification⁷: A61F 2/36
- (21) International Application Number: PCT/US01/22999
- (22) International Filing Date: 20 July 2001 (20.07.2001)
- (25) Filing Language: English
- (26) Publication Language: English
- (30) Priority Data:

60/219,955	20 July 2000 (20.07.2000)	US
60/219,963	20 July 2000 (20.07.2000)	US
- (71) Applicant: DEPUY ORTHOPAEDICS, INC. [US/US];
700 Orthopaedic Drive, P.O. Box 988, Warsaw, IN 46581-0988 (US).
- (72) Inventors: DESPRES, Alfred S., III; 4607 Hillwood Drive, Shingle Springs, CA 95682 (US). HAYES, Daniel, E., Jr.; 6500 Wagon Loop, Placerville, CA 95667 (US).
- (74) Agent: PANDISCIO, Mark, J.; Pandiscio & Pandiscio, 470 Totten Pond Road, Waltham, MA 02451-1914 (US).
- (81) Designated States (*national*): AE, AG, AL, AM, AT, AU, AZ, BA, BB, BG, BR, BY, BZ, CA, CH, CN, CO, CR, CU, CZ, DE, DK, DM, DZ, EC, EE, ES, FI, GB, GD, GE, GH, GM, HR, HU, ID, IL, IN, IS, JP, KE, KG, KP, KR, KZ, LC, LK, LR, LS, LT, LU, LV, MA, MD, MG, MK, MN, MW, MX, MZ, NO, NZ, PL, PT, RO, RU, SD, SE, SG, SI, SK, SL, TJ, TM, TR, TT, TZ, UA, UG, UZ, VN, YU, ZA, ZW.
- (84) Designated States (*regional*): ARIPO patent (GH, GM, KE, LS, MW, MZ, SD, SL, SZ, TZ, UG, ZW), Eurasian patent (AM, AZ, BY, KG, KZ, MD, RU, TJ, TM), European patent (AT, BE, CH, CY, DE, DK, ES, FI, FR, GB, GR, IE, IT, LU, MC, NL, PT, SE, TR), OAPI patent (BF, BJ, CF, CG, CI, CM, GA, GN, GQ, GW, ML, MR, NE, SN, TD, TG).

[Continued on next page]

(54) Title: MODULAR FEMORAL STEM COMPONENT FOR A HIP JOINT PROSTHESIS

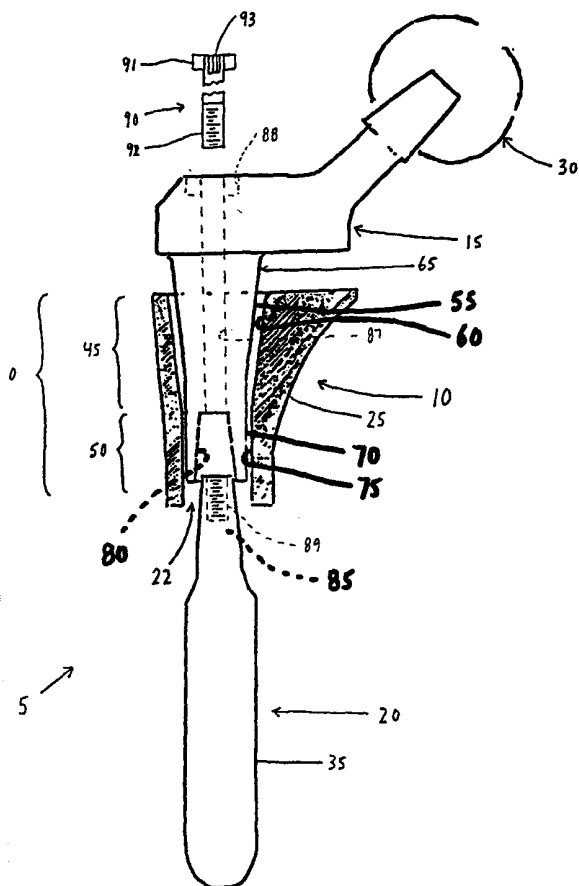

(57) Abstract: A prosthetic femoral stem component (5) comprising a body element (10), a neck element (15) and a stem element (20), with the body element (10), neck element (15) and stem element (20) being secured to one another with a modular connection (40), wherein the modular connection (40) comprises a taper junction (45) and an engaged-fit junction (50).



WO 02/07653 A1



Published:

- *with international search report*
- *before the expiration of the time limit for amending the claims and to be republished in the event of receipt of amendments*

For two-letter codes and other abbreviations, refer to the "Guidance Notes on Codes and Abbreviations" appearing at the beginning of each regular issue of the PCT Gazette.

MODULAR FEMORAL STEM COMPONENTFOR A HIP JOINT PROSTHESISReference To Pending Prior Applications

5 This application claims benefit of:

(1) pending prior U.S. Provisional Patent
Application Serial No. 60/219,955, filed 07/20/00 by
Alfred S. Despres III et al. for MODULAR ORTHOPEDIC
CONNECTION (Attorney's Docket No. HAYES-1 PROV); and

10 (2) pending prior U.S. Provisional Patent
Application Serial No. 60/219,963, filed 07/20/00 by
Alfred S. Despres III et al. for FORCE COUPLE
CONNECTION (Attorney's Docket No. HAYES-2 PROV).

15 The two above-identified patent applications are
hereby incorporated herein by reference.

Field Of The Invention

20 This invention relates to surgical apparatus and
procedures in general, and more particularly to
orthopedic prostheses for restoring the hip joint.

- 2 -

Background Of The Invention

Joint replacement surgery seeks to replace portions of a joint with prosthetic components so as to provide long-lasting function and pain-free mobility.

For example, in the case of a prosthetic total hip joint, the head of the femur is replaced with a prosthetic femoral stem component, and the socket of the acetabulum is replaced by a prosthetic acetabular cup component, whereby to provide a prosthetic total hip joint.

In the case of a prosthetic total knee joint, the top of the tibia is replaced by a prosthetic tibial component, and the bottom of the femur is replaced by a prosthetic femoral component, whereby to provide a prosthetic total knee joint.

The present invention is directed to orthopedic prostheses for restoring the hip joint and, more particularly, to improved prosthetic femoral stem components.

- 3 -

Prosthetic femoral stem components typically
comprise a proximal section for seating in the
proximal section of the resected femur and presenting
a ball for seating in the acetabular socket, and a
5 distal section for seating in the femur's medullary
canal so as to extend along the shaft of the femur.

It is, of course, important that the prosthetic
femoral stem component make a proper fit with the
surrounding bone. To this end, prosthetic femoral
10 stem components are typically offered in range of
different sizes in an effort to accommodate variations
in patient anatomy. However, despite this, it has
been found that it can be difficult to provide the
correct prosthetic femoral stem component for
15 patients. This is due to the wide variation in
patient anatomies and to the practical limitations of
hospital inventory. By way of example, where a
femoral component is selected having a proximal
section appropriately sized for the proximal section
20 of the resected femur, the distal section of the
prosthesis may not be appropriately sized for proper

- 4 -

seating in the distal section of the femur. This can present serious problems for the patient, including problems relating to joint stability and pain.

On account of the foregoing, there has been
5 substantial interest in forming prosthetic femoral stem components out of a plurality of separate elements, wherein each of the elements may be independently selected so as to most closely approximate patient anatomy, and wherein the separate
10 elements may be assembled to one another in situ, using modular connections, so as to provide the best possible prosthetic femoral stem component for the patient.

Once deployed in the patient's body, the
15 prosthetic femoral stem component, and hence the modular connections securing the separate elements to one another, are subjected to axial, bending and torsional loads. While different types of modular connections are known in the art, no one modular
20 connection is ideal for dealing with all three types of loads, i.e., axial, bending and torsional loads.

- 5 -

By way of example, taper connections generally accommodate axial (i.e., compressive) loads well, but they generally do not accommodate bending and torsional loads particularly well. By way of further example, concentric cylinder connections generally accommodate bending loads well, but they generally do not accommodate axial and torsional loads particularly well.

10 Summary Of The Invention

As a result, one object of the present invention is to provide an improved modular connection for connecting together a plurality of separate elements so as to form a prosthetic femoral stem component.

15 Another object of the present invention is to provide an improved prosthetic femoral stem component.

And another object of the present invention is to provide an improved prosthetic total hip joint.

20 Still another object of the present invention is to provide an improved method for restoring a hip joint.

- 6 -

These and other objects are addressed by the provision and use of the present invention.

In one form of the invention, there is provided an improved modular connection for connecting together
5 a plurality of separate elements so as to form a prosthetic femoral stem component, the improved modular connection comprising, in combination, a taper junction and an engaged-fit junction.

In another form of the invention, there is
10 provided an improved prosthetic femoral stem component comprising a body element, a neck element and a stem element, with the body element, neck element and stem element being secured to one another with a modular connection, wherein the modular connection comprises,
15 in combination, a taper junction and an engaged-fit junction.

In another form of the invention, there is provided an improved prosthetic total hip joint comprising a prosthetic femoral stem component and a
20 prosthetic acetabular cup component, wherein the femoral stem component comprises a body element, a

- 7 -

neck element and a stem element, with the body
element, neck element and stem element being secured
to one another with a modular connection, wherein the
modular connection comprises, in combination, a taper
5 junction and an engaged-fit junction.

In another form of the invention, there is
provided an improved method for restoring a hip joint,
wherein the method comprises the steps of: resecting
the head of the femur and preparing the interior of
10 the femur to receive a prosthetic femoral stem
component; assembling a prosthetic femoral stem
component comprising a body element, a neck element
and a stem element by selecting appropriately sized
elements and securing them together with a modular
15 connection, wherein the modular connection comprises,
in combination, a taper junction and an engaged-fit
junction; and seating the prosthetic femoral stem
component in the femur.

20

Brief Description Of The Drawings

These and other objects and features of the present invention will be more fully disclosed or rendered obvious by the following detailed description
5 of the preferred embodiments of the invention, which are to be considered together with the accompanying drawings wherein like numbers refer to like parts and further wherein:

Fig. 1 is a schematic, exploded side view of a
10 prosthetic femoral stem component formed in accordance with the present invention;

Fig. 2 is an enlarged, schematic, exploded side view of the modular connection used to form the prosthetic femoral stem component shown in Fig. 1;

15 Fig. 3 is a schematic side view of a prosthetic total hip joint formed in accordance with the present invention;

Fig. 4 is a schematic side view of another form of prosthetic femoral stem component formed in
20 accordance with the present invention; and

- 9 -

Fig. 5 is a schematic side view of a prosthetic total hip joint using the prosthetic femoral stem component shown in Fig. 4.

5 Detailed Description Of The Preferred Embodiments

Looking first at Fig. 1, there is shown a prosthetic femoral stem component 5 formed in accordance with the present invention. Prosthetic femoral stem component 5 generally comprises a body element 10, a neck element 15 and a stem element 20. Body element 10 includes a central aperture 22 into which portions of neck element 15 and stem element 20 extend. Body element 10 is selected so that its outer surface 25 is properly sized to be seated in the proximal section of a resected femur. Neck element 15 is selected so that when it is mounted to the remainder of prosthetic femoral stem component 5 deployed within the femur, the neck element's ball 30 will be properly seated in the hip joint's corresponding acetabular cup. Stem 20 is selected so

10

15

20

- 10 -

that its outer surface 35 is properly sized to be seated within the medullary canal of the femur.

In accordance with the present invention, body element 10, neck element 15 and stem element 20 are adapted to be secured to one another using an improved
5 modular connection 40 so as to form the complete prosthetic femoral stem component 5.

More particularly, modular connection 40 comprises, in combination, two load-bearing junctions:
10 a taper junction 45 and an engaged-fit junction 50.

Looking now at Figs. 1 and 2, taper junction 45 is formed by the interaction of a first taper 55 with a corresponding second taper 60. More particularly, first taper 55 is formed on the shaft 65 of neck
15 element 15. Second taper 60 is formed along a portion of the sidewall defining the body element's central aperture 22. First taper 55 and second taper 60 seat securely against one another so as to together form the load-bearing taper junction 45.

20 Still looking now at Figs. 1 and 2, engaged-fit junction 50 is formed by the interaction of a first

- 11 -

concentric wall 70 with a second concentric wall 75. More particularly, first concentric wall 70 is formed on shaft 65 of neck element 15. Preferably first concentric wall 70 is disposed on shaft 65 coaxial with, and distal to, first taper 55. Second concentric wall 75 is formed along a portion of the sidewall defining the body element's central aperture 22. Preferably second concentric wall 75 is disposed on body element 10 coaxial with, and distal to, second taper 60. First concentric wall 70 and second concentric wall 75 seat securely against one another so as to form the load-bearing engaged-fit junction 50.

In general, the engaged-fit junction 50 is a mechanical connection that achieves stability by the deformation of one member so that it is pressure locked against a constraining second member. This deformation can be expansion (e.g., as in a taper expanded collet) or contraction (e.g., as in a force fit). The deformation can also be effected by thermal expansion or thermal contraction (e.g., as with a

- 12 -

shape memory alloy such as Nitinol or the like).

Regardless of how the deformation is achieved, the resulting mechanical connection has surfaces which are forcefully engaged against one another as a result of the deformation, whereby to establish the engaged-fit junction.

As noted above, there are a number of ways in which first concentric wall 70 and second concentric wall 75 can be made to seat securely against one another so as to form the load-bearing engaged-fit junction 50.

For example, first concentric wall 70 can be made slightly oversized relative to second concentric wall 75, such that force fitting first concentric wall 70 internal to second concentric wall 75 will create the engaged-fit junction 50.

Alternatively, and in accordance with a preferred form of the present invention, the distal end of the neck element's shaft 65 may be formed with a recess 80, and the proximal end of stem element 20 may include a projection 85 for insertion into recess 80.

- 13 -

More particularly, projection 85 is diametrically oversized relative to recess 80, such that insertion of projection 85 into recess 80 will cause a radial expansion of first concentric wall 70 into engagement with second concentric wall 75, whereby to create the engaged-fit junction 50. In one preferred form of the invention, recess 80 and projection 85 are both tapered, and the distal end of neck 15 is a split collet. Alternatively, the distal end of neck 15 may be formed out of a material sufficiently resilient to engage second concentric wall 75 without being split. If desired, a threaded bolt can thereafter lock stem element 20 to neck element 15. By way of example, neck element 15 can include a bore 87 and a counterbore 88, and stem element 20 can include a threaded bore 89. Then a bolt 90, having a head 91 and a distal thread 92, may be driven, via a recessed hex drive 93, so that its distal thread 92 seats in stem threaded bore 89 and its head 91 seats in neck counterbore 88, whereby to lock stem element 20 to neck element 15.

- 14 -

Due to the unique construction of modular connection 40, the prosthetic femoral stem component 5 is able to accommodate axial, bending and torsional loads better than prior art devices. More particularly, modular connection 40 simultaneously provides two load-bearing junctions: the taper junction 45 and the engaged-fit junction 50. The taper junction 45 accommodates axial (i.e., compressive) loads extremely well. At the same time, the engaged-fit junction 50 accommodates bending and torsional loads extremely well. Additionally, the engaged-fit junction 50 stabilizes the taper junction 45 against bending and torsional loads. Together, the two load-bearing junctions collectively handle axial, bending and torsional loads significantly better than prior art devices.

Looking next at Fig. 3, prosthetic femoral stem component 5 is preferably used as follows.

First, the patient's femur 100 is prepared, e.g., by resecting the head of the femur, and clearing the

- 15 -

interior of the femur to receive the prosthetic femoral stem component.

Next, a body element 10 is selected so that its outer surface 25 is properly sized to be seated in the proximal section of the resected femur. Then a neck element 15 is selected so that when it is mounted to the remainder of the prosthetic femoral stem component deployed within the femur, the neck element's ball 30 will be properly seated in the hip joint's corresponding acetabular cup 105. Then a stem 20 is selected so that its outer surface is properly sized to be seated within the medullary canal 110 of the femur.

Next, body element 10, neck element 15 and stem element 20 are assembled into the prosthetic femoral stem component 5. This is preferably done by passing the distal end of the neck element's shaft 65 down the body element's central aperture 22 until first taper 55 engages second taper 60, whereby to create the tapered junction 45 (Figs. 1 and 2), and then passing the proximal end of stem element 20 up into central

- 16 -

aperture 22 until the stem element's oversized projection 85 is inserted into recess 80, whereupon first concentric wall 70 will expand into engagement with second concentric wall 75, whereby to create the engaged-fit junction 50 (Figs. 1 and 2). If desired, threaded bolt 90 can be used to lock system element 20 to neck element 15.

Next, prosthetic femoral stem component 5 is deployed in the resected femur, the acetabular side of the joint is prepared (i.e., prosthetic acetabular cup component 105 is deployed in the patient's acetabulum 115), ball 30 is set on neck element 15, and the hip is reduced.

As noted above, a bolt 90 can be passed down a bore 87 in neck element 15 and secured to stem element 20 as as to secure stem element 20 to neck element 15. Alternatively, other arrangements can also be used. Thus, for example, and looking now at Figs. 4 and 5, stem element 20 can include a shaft 85A proximal to its projection 85, with the proximal end of shaft 85A including screw threads 85B, and with this shaft 85A

- 17 -

being passed up through bore 87 in neck element 15. A nut 90A engages threads 85B and seats in the neck element's counterbore 88 to lock stem element 20 to neck element 15.

5 It will be understood that many additional changes in the details, materials, steps and arrangement of parts, which have been herein described and illustrated in order to explain the nature of the invention, may be made by those skilled the art
10 without departing from the principles and scope of the present invention.

- 18 -

What Is Claimed Is:

1. A modular connection for connecting together
a plurality of separate elements so as to form a
5 prosthetic femoral stem component, said modular
connection comprising, in combination, a taper
junction and an engaged-fit junction.

2. A modular connection according to claim 1
10 wherein said taper junction is formed by the
interaction of a first taper with a second taper.

3. A modular connection according to claim 2
wherein said first taper is formed on the shaft of a
15 neck element, and said second taper is formed along a
portion of a sidewall defining an aperture extending
through a body element.

4. A modular connection according to claim 1
20 wherein said engaged-fit junction is formed by the

- 19 -

interaction of a first concentric wall with a second concentric wall.

5 5. A modular connection according to claim 4
wherein said first concentric wall is formed on a
shaft of a neck element, and said second concentric
wall is formed along a portion of the sidewall
defining an aperture extending through a body element.

10 6. A modular connection according to claim 1
wherein:

 said taper junction is formed by the interaction
of a first taper with a second taper, with said first
taper being formed on the shaft of a neck element, and
15 said second taper being formed along a portion of a
sidewall defining an aperture extending through a body
element; and

 said engaged-fit junction is formed by the
interaction of a first concentric wall with a second
20 concentric wall, with said first concentric wall being
formed on the shaft of the neck element, and said

- 20 -

second concentric wall being formed along a portion of the sidewall defining the aperture extending through the body element.

5 7. A modular connection according to claim 6 wherein said first concentric wall is disposed on the shaft of the neck element coaxial with, and distal to, said first taper.

10 8. A modular connection according to claim 7 wherein said second concentric wall is disposed on the body element coaxial with, and distal to, said second taper.

15 9. A modular connection according to claim 4 wherein said first concentric wall is located internally of said second concentric wall.

20 10. A modular connection according to claim 9 wherein said first concentric wall is deformed so as

- 21 -

to be pressure locked against said second concentric wall.

5 11. A modular connection according to claim 10 wherein said first concentric wall is radially expanded so as to be pressure locked against said second concentric wall.

10 12. A modular connection according to claim 11 wherein said first concentric wall is formed on a shaft of a neck element, and said second concentric wall is formed along a portion of the sidewall defining an aperture extending through a body element, and further wherein said first concentric wall is
15 radially expanded by insertion of a stem element into a recess formed in the neck element.

20 13. A prosthetic femoral stem component comprising a body element, a neck element and a stem element, with the body element, neck element and stem element being secured to one another with a modular

- 22 -

connection, wherein said modular connection comprises, in combination, a taper junction and an engaged-fit junction.

5 14. A prosthetic femoral stem component according to claim 13 wherein said taper junction is formed by the interaction of a first taper with a second taper.

10 15. A prosthetic femoral stem component according to claim 14 wherein said first taper is formed on the shaft of said neck element, and said second taper is formed along a portion of a sidewall defining an aperture extending through said body
15 element.

 16. A prosthetic femoral stem component according to claim 13 wherein said engaged-fit junction is formed by the interaction of a first
20 concentric wall with a second concentric wall.

- 23 -

17. A prosthetic femoral stem component according to claim 16 wherein said first concentric wall is formed on a shaft of said neck element, and said second concentric wall is formed along a portion of the sidewall defining an aperture extending through said body element.

18. A prosthetic femoral stem component according to claim 13 wherein:

10 said taper junction is formed by the interaction of a first taper with a second taper, with said first taper being formed on the shaft of said neck element, and said second taper being formed along a portion of a sidewall defining an aperture extending through said body element; and

15 said engaged-fit junction is formed by the interaction of a first concentric wall with a second concentric wall, with said first concentric wall being formed on the shaft of said neck element, and said 20 second concentric wall being formed along a portion of

- 24 -

the sidewall defining the aperture extending through
said body element.

19. A prosthetic femoral stem component
5 according to claim 18 wherein said first concentric
wall is disposed on the shaft of the neck element
coaxial with, and distal to, said first taper.

20. A prosthetic femoral stem component
10 according to claim 19 wherein said second concentric
wall is disposed on the body element coaxial with, and
distal to, said second taper.

21. A prosthetic femoral stem component
15 according to claim 16 wherein said first concentric
wall is located internally of said second concentric
wall.

22. A prosthetic femoral stem component
20 according to claim 21 wherein said first concentric

- 25 -

wall is deformed so as to be pressure locked against said second concentric wall.

23. A prosthetic femoral stem component
5 according to claim 22 wherein said first concentric wall is radially expanded so as to be pressure locked against said second concentric wall.

24. A prosthetic femoral stem component
10 according to claim 23 wherein said first concentric wall is formed on a shaft of said neck element, and said second concentric wall is formed along a portion of the sidewall defining an aperture extending through said body element, and further wherein said first
15 concentric wall is radially expanded by insertion of said stem element into a recess formed in said neck element.

25. A prosthetic total hip joint comprising a
20 prosthetic femoral stem component and a prosthetic acetabular cup component, wherein said femoral stem

- 26 -

component comprises a body element, a neck element and
a stem element, with the body element, neck element
and stem element being secured to one another with a
modular connection, wherein said modular connection
5 comprises, in combination, a taper junction and an
engaged-fit junction.

26. A method for restoring a hip joint, wherein
the method comprises the steps of:

10 resecting the head of the femur and preparing the
interior of the femur to receive a prosthetic femoral
stem component;

assembling a prosthetic femoral stem component
comprising a body element, a neck element and a stem
15 element by selecting appropriately sized elements and
securing them together with a modular connection,
wherein the modular connection comprises, in
combination, a taper junction and an engaged-fit
junction; and

20

- 27 -

seating the prosthetic femoral stem component in
the femur.

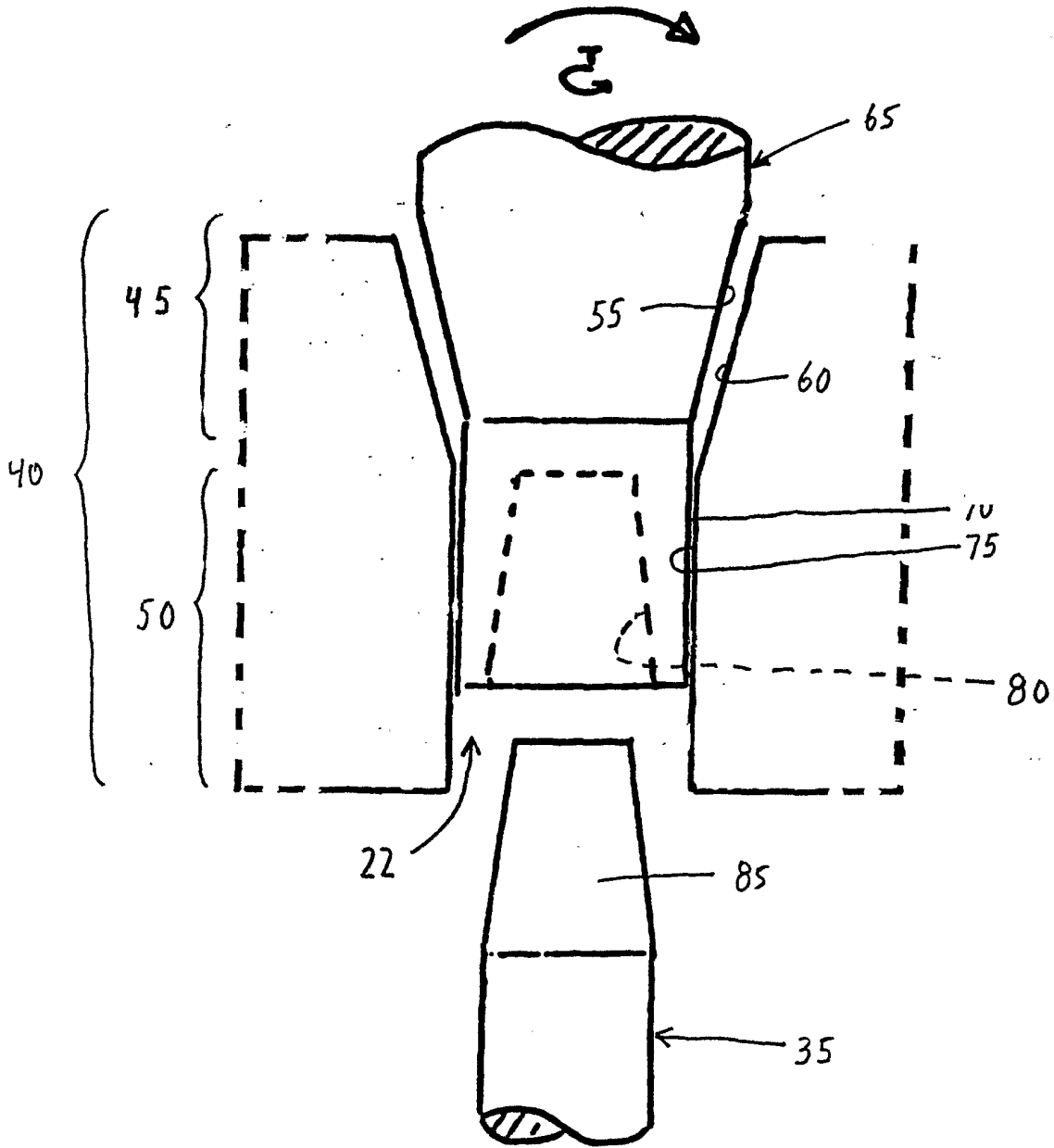

FIG. 2

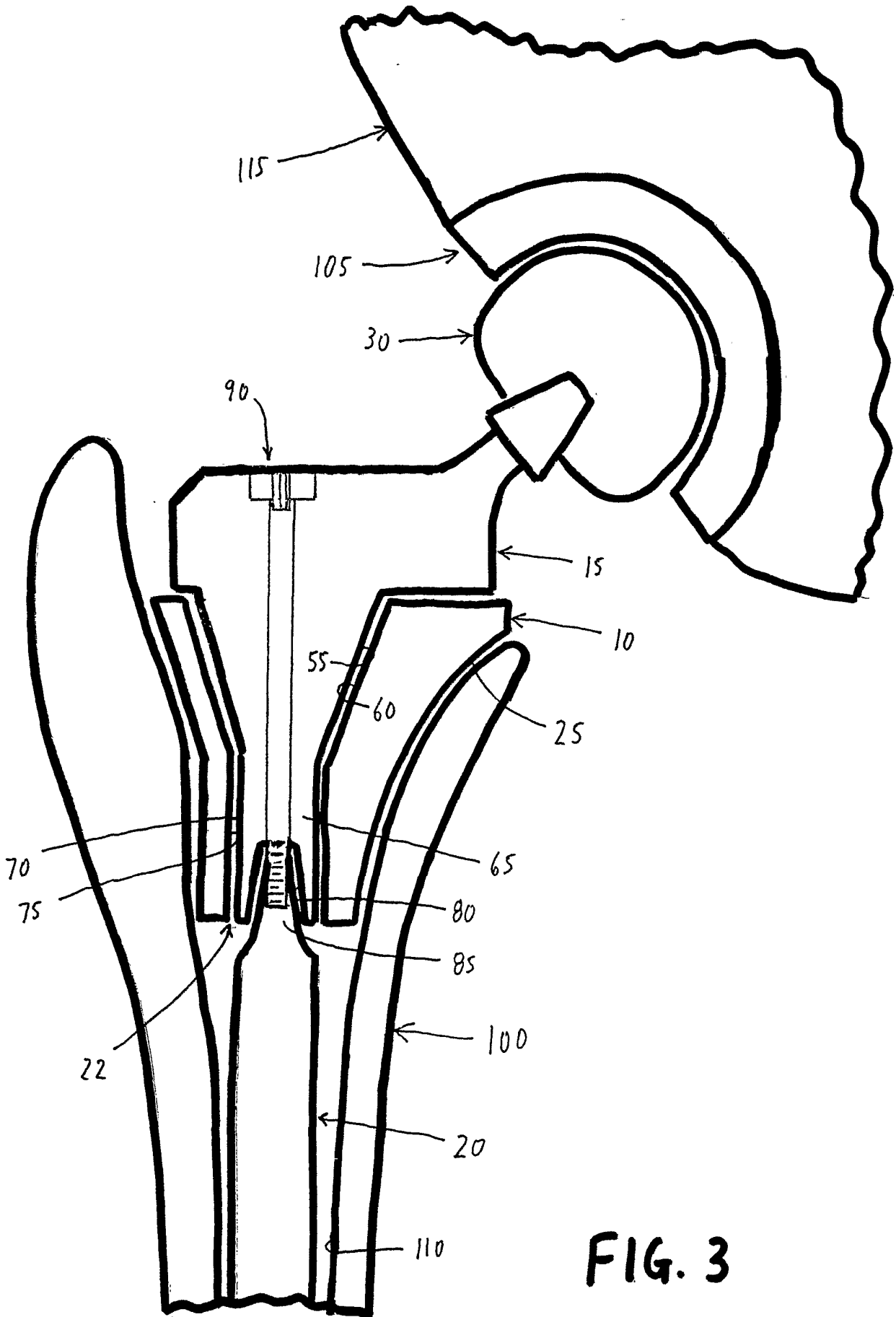

FIG. 3

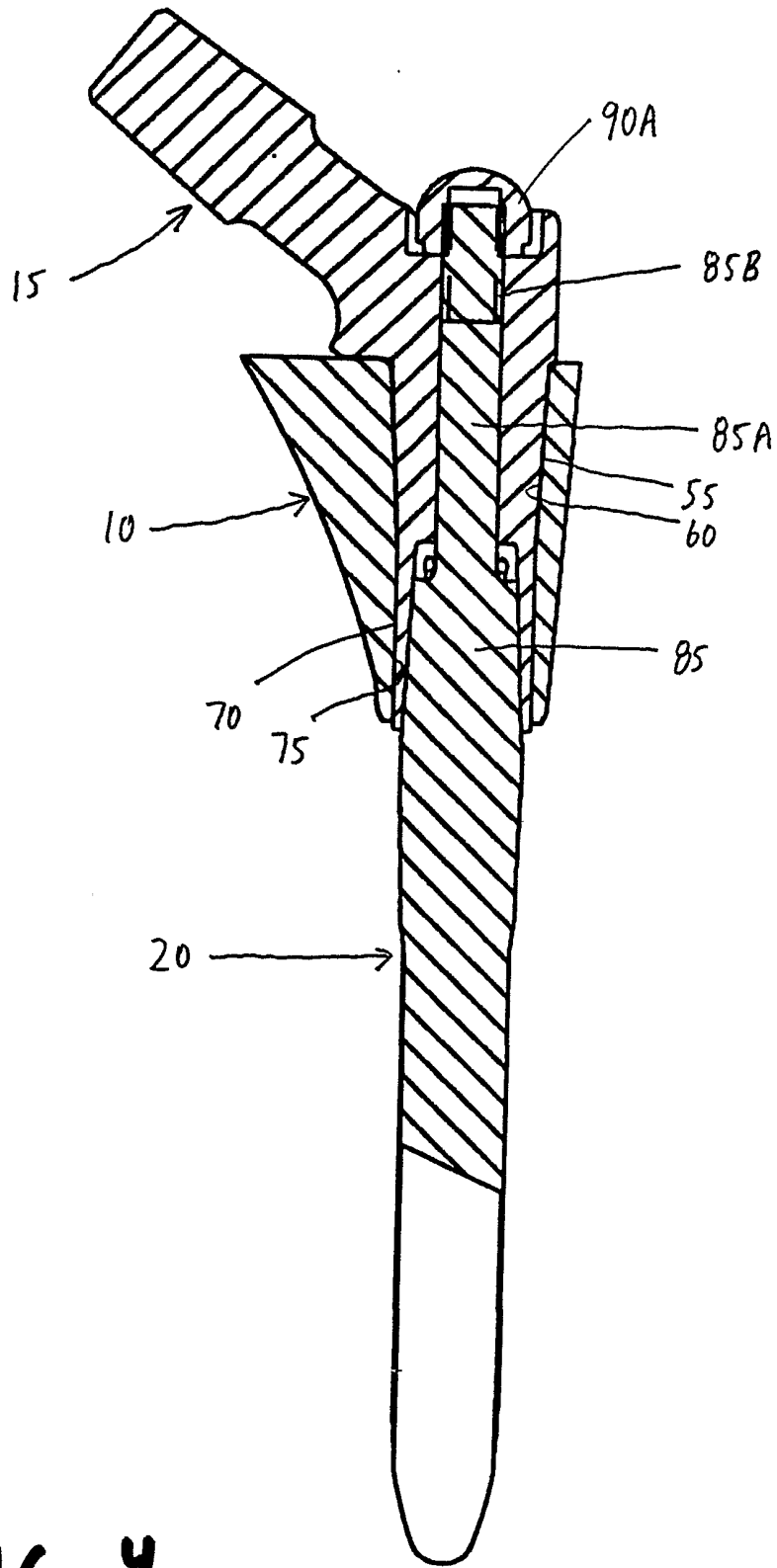

FIG. 4

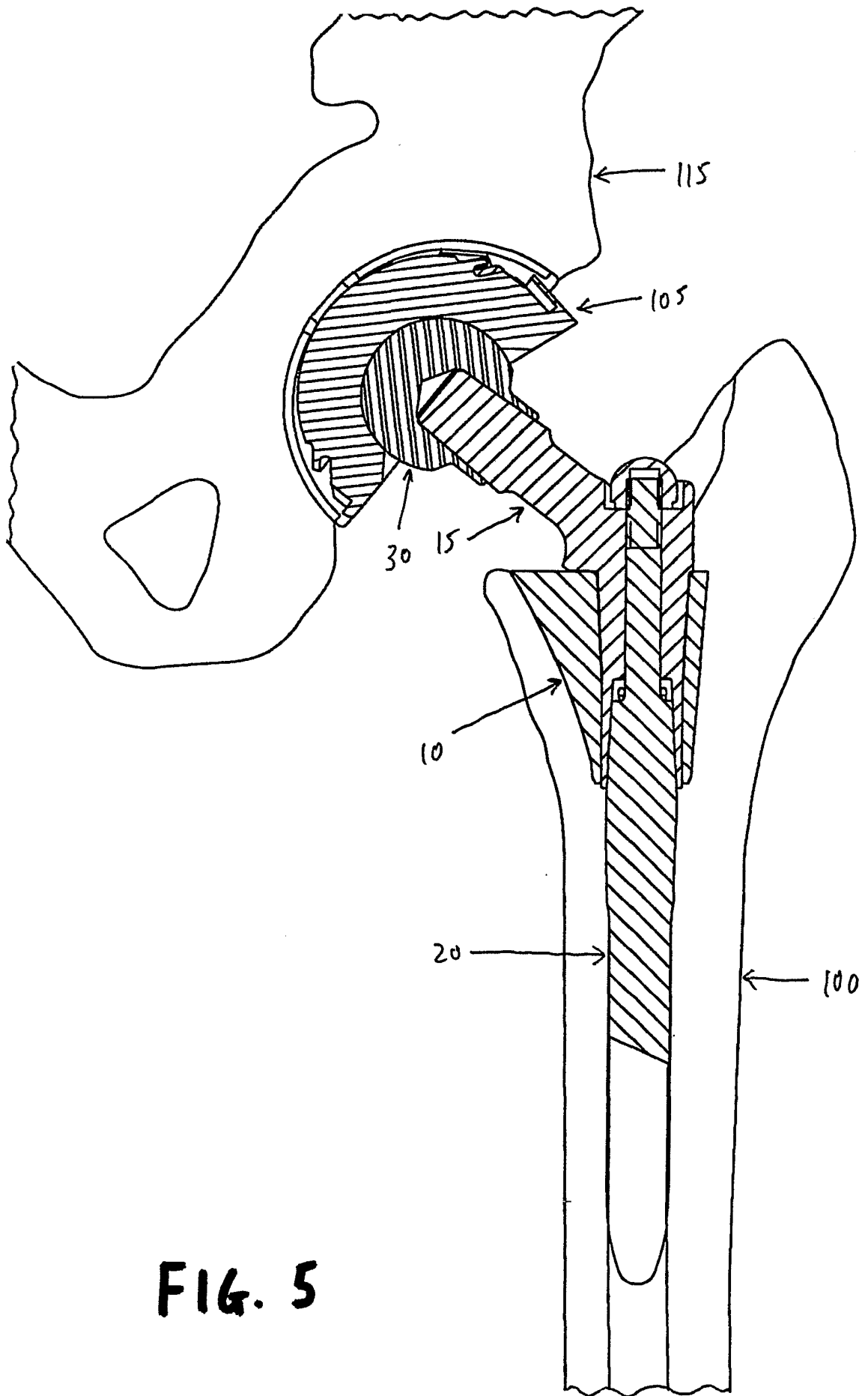

FIG. 5

INTERNATIONAL SEARCH REPORT

International application No.
PCT/US01/22999

A. CLASSIFICATION OF SUBJECT MATTER		
IPC(7) : A61F 2/36 US CL : 623/23.15		
According to International Patent Classification (IPC) or to both national classification and IPC		
B. FIELDS SEARCHED		
Minimum documentation searched (classification system followed by classification symbols)		
U.S. : 623/23.15, 22.11, 22.15, 22.40, 22.41, 22.42, 22.43, 22.44, 22.45, 23.21, 23.22		
Documentation searched other than minimum documentation to the extent that such documents are included in the fields searched		
Electronic data base consulted during the international search (name of data base and, where practicable, search terms used)		
C. DOCUMENTS CONSIDERED TO BE RELEVANT		
Category*	Citation of document, with indication, where appropriate, of the relevant passages	Relevant to claim No.
X	US 5,725,592 A (WHITE et al) 10 March 1998, see all the document.	1-26
A, E	US 6,264,699 B1 (NOILES et al) 24 July 2001, see complete document.	1-26
A, E	US 6,299,648 B1 (DOUBLER et al) 09 October 2001, see complete document.	1-24, 26
<input type="checkbox"/> Further documents are listed in the continuation of Box C. <input type="checkbox"/> See patent family annex.		
* Special categories of cited documents:	"T"	later document published after the international filing date or priority date and not in conflict with the application but cited to understand the principle or theory underlying the invention
"A" document defining the general state of the art which is not considered to be of particular relevance	"X"	document of particular relevance; the claimed invention cannot be considered novel or cannot be considered to involve an inventive step when the document is taken alone
"E" earlier document published on or after the international filing date	"Y"	document of particular relevance; the claimed invention cannot be considered to involve an inventive step when the document is combined with one or more other such documents, such combination being obvious to a person skilled in the art
"L" document which may throw doubts on priority claim(s) or which is cited to establish the publication date of another citation or other special reason (as specified)	"&"	document member of the same patent family
"O" document referring to an oral disclosure, use, exhibition or other means		
"P" document published prior to the international filing date but later than the priority date claimed		
Date of the actual completion of the international search	Date of mailing of the international search report	
19 OCTOBER 2001	27 DEC 2001	
Name and mailing address of the ISA/US Commissioner of Patents and Trademarks Box PCT Washington, D.C. 20231	Authorized officer	
Facsimile No. (703) 305-3230	EDUARDO C. ROBERT <i>Eduardo C. Robert</i>	
	Telephone No. (703) 305-7333	