



US00D748072S

(12) **United States Design Patent**
Jones

(10) **Patent No.:** **US D748,072 S**

(45) **Date of Patent:** **** Jan. 26, 2016**

(54) **SOUND BAR AUDIO SPEAKER**
(71) Applicant: **Emo Labs, Inc.**, Waltham, MA (US)
(72) Inventor: **Terrence Keith Jones**, Sharon, MA (US)
(73) Assignee: **Emo Labs, Inc.**, Wellesley, MA (US)

(**) Term: **14 Years**

(21) Appl. No.: **29/484,920**

(22) Filed: **Mar. 14, 2014**

(51) **LOC (10) Cl.** **14-01**

(52) **U.S. Cl.**
USPC **D14/204**

(58) **Field of Classification Search**
USPC D14/172, 207, 204, 209.1, 210–215;
181/148, 152, 153, 157, 192, 198, 199;
381/301–303, 332, 333, 336, 345, 361
CPC H04M 1/03; H04M 1/035; H04R 1/02;
H04R 1/06; H04R 1/021; H04R 1/025;
H04R 1/026; H04R 1/105; H04R 1/288;
H04R 1/323; H04R 1/345; H04R 1/403;
H04R 1/2803; H04R 1/2834; H04R 3/12;
H04R 5/02; H04R 2203/12

See application file for complete search history.

(56) **References Cited**

U.S. PATENT DOCUMENTS

D128,141 S * 7/1941 Meyer D6/472
2,895,062 A 7/1959 Abbott
3,057,961 A 10/1962 Turner
3,093,710 A 6/1963 Ten Eyck
3,412,518 A * 11/1968 Waite 52/591.4
3,509,387 A 4/1970 Davies et al.
3,544,201 A 12/1970 Fowler et al.
4,047,060 A 9/1977 Schafft
4,056,742 A 11/1977 Tibbetts
4,088,915 A 5/1978 Kodama
4,140,203 A 2/1979 Niguchi et al.
4,170,742 A 10/1979 Itagaki et al.
4,181,865 A 1/1980 Kohyama
4,186,323 A 1/1980 Cragg et al.
4,198,550 A 4/1980 Matsuda et al.

4,241,313 A 12/1980 Takehara
4,291,205 A 9/1981 Kamon et al.
4,297,185 A 10/1981 Chevreux et al.
4,315,557 A 2/1982 Nakaya et al.
4,352,961 A 10/1982 Kumada et al.
4,454,386 A 6/1984 Koyano
4,503,564 A 3/1985 Edelman et al.
4,571,553 A 2/1986 Yokoyama
4,573,189 A 2/1986 Hall
4,578,613 A 3/1986 Posthuma de Boer et al.
4,593,160 A 6/1986 Nakamura
4,607,145 A 8/1986 Ravinet et al.
4,618,814 A 10/1986 Kato et al.
4,625,138 A 11/1986 Ballato
4,625,259 A 11/1986 Krechmer et al.
4,638,207 A 1/1987 Radice
4,680,800 A 7/1987 Bank et al.
4,751,419 A 6/1988 Takahata
4,807,294 A 2/1989 Iwata et al.
4,847,904 A 7/1989 McShane
4,864,624 A 9/1989 Tichy
4,899,390 A 2/1990 Takewa et al.
4,969,197 A 11/1990 Takaya
4,979,219 A 12/1990 Lin
4,992,692 A 2/1991 Dias
4,997,058 A 3/1991 Bertagni
5,031,222 A 7/1991 Takaya
5,081,683 A 1/1992 Torgeson
5,115,472 A 5/1992 Park et al.
5,193,119 A 3/1993 Tontini et al.
5,265,165 A 11/1993 Rauch
5,283,835 A 2/1994 Athanas
5,368,917 A 11/1994 Rehfeld et al.
5,388,160 A 2/1995 Hashimoto et al.
5,392,000 A 2/1995 Gillig
5,428,832 A 6/1995 Nohara et al.
5,473,214 A 12/1995 Hildebrand
5,524,058 A 6/1996 Moseley
5,526,421 A 6/1996 Berger et al.
5,575,827 A 11/1996 Pieniecki
5,608,282 A 3/1997 Wilber et al.
5,615,270 A 3/1997 Miller et al.
5,638,454 A 6/1997 Jones et al.
5,638,456 A 6/1997 Conley et al.
5,642,332 A 6/1997 Chang et al.
5,652,801 A 7/1997 Paddock
5,676,612 A 10/1997 Schellekens et al.
5,684,689 A 11/1997 Hahn
5,684,884 A 11/1997 Nakaya et al.
5,705,878 A 1/1998 Lewis et al.
5,711,058 A 1/1998 Frey
5,736,808 A 4/1998 Szilagyi et al.
5,751,827 A 5/1998 Takahashi

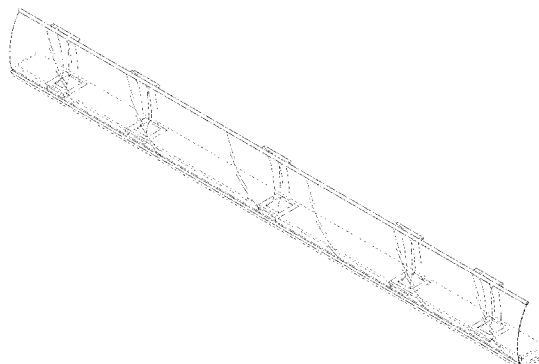
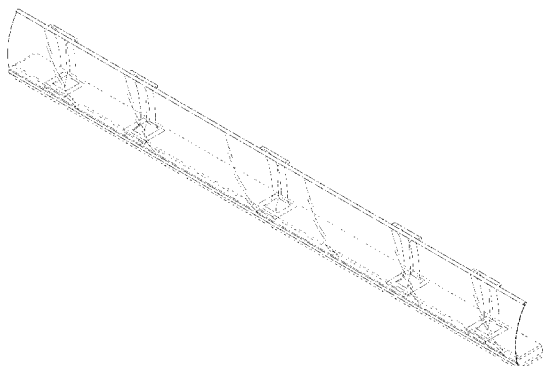

5,767,612 A	6/1998	Takeuchi et al.	8,395,371 B2	3/2013	Govil
5,773,102 A	6/1998	Rehfeld	2001/0026626 A1	10/2001	Athanas
5,780,958 A	7/1998	Strugach et al.	2001/0038701 A1	11/2001	Corynen
5,802,195 A	9/1998	Regan et al.	2001/0052627 A1	12/2001	Takahashi et al.
5,825,902 A	10/1998	Fujishima	2002/0001392 A1	1/2002	Isono et al.
5,828,768 A	10/1998	Eatwell et al.	2002/0044668 A1	4/2002	Azima
5,856,956 A	1/1999	Toki	2002/0153194 A1	10/2002	Pocock et al.
5,867,302 A	2/1999	Fleming	2003/0161479 A1	8/2003	Yang et al.
5,901,231 A	5/1999	Parrella et al.	2004/0037441 A1	2/2004	Konishi et al.
5,965,249 A	10/1999	Sutton et al.	2004/0189151 A1	9/2004	Athanas
5,973,441 A	10/1999	Lo et al.	2004/0228501 A1	11/2004	Saiki et al.
5,977,688 A	11/1999	Utsunomiya et al.	2005/0053257 A1	3/2005	Johnson et al.
6,003,766 A	12/1999	Azima et al.	2005/0069430 A1	3/2005	Sugahara
6,023,123 A	2/2000	Petiet	2005/0180592 A1	8/2005	Miura
6,028,389 A	2/2000	Bernstein	2005/0232435 A1	10/2005	Stothers et al.
6,031,926 A	2/2000	Azima et al.	2005/0288039 A1	12/2005	Liou
6,058,196 A	5/2000	Heron	2006/0066803 A1	3/2006	Aylward et al.
6,060,811 A	5/2000	Fox et al.	2006/0269087 A1	11/2006	Johnson et al.
6,064,746 A	5/2000	Nakamura et al.	2006/0290236 A1	12/2006	Ikehashi
6,144,746 A	11/2000	Azima et al.	2007/0000720 A1	1/2007	Noro et al.
6,151,402 A	11/2000	Azima et al.	2007/0003100 A1	1/2007	Liu
6,181,797 B1	1/2001	Parrella et al.	2007/0007859 A1	1/2007	Weber
6,188,775 B1	2/2001	Azima et al.	2007/0092088 A1	4/2007	Chang
6,195,440 B1	2/2001	Warnaka et al.	2007/0133837 A1	6/2007	Suzuki et al.
6,198,831 B1	3/2001	Azima et al.	2007/0223714 A1	9/2007	Nishikawa
6,215,881 B1	4/2001	Azima et al.	2007/0243364 A1	10/2007	Maekawa et al.
6,215,882 B1	4/2001	Heron	2007/0260019 A1	11/2007	Ohme et al.
6,215,884 B1	4/2001	Parrella et al.	2007/0297620 A1	12/2007	Choy
6,218,766 B1	4/2001	Warnaka et al.	2008/0007829 A1	1/2008	Mizushima et al.
6,243,473 B1	6/2001	Azima et al.	2008/0138541 A1	6/2008	Moto et al.
6,247,551 B1	6/2001	Heron	2008/0138543 A1	6/2008	Hoshino et al.
6,278,790 B1	8/2001	Davis et al.	2008/0273720 A1	11/2008	Johnson et al.
6,294,859 B1	9/2001	Jaenker	2009/0136690 A1	5/2009	Sasada
6,427,017 B1	7/2002	Toki	2009/0190791 A1	7/2009	Unruh et al.
6,437,485 B1	8/2002	Johansson	2009/0200896 A1	8/2009	Morris et al.
6,472,797 B1	10/2002	Kishimoto	2009/0285431 A1	11/2009	Carlson et al.
6,504,286 B1	1/2003	Porat et al.	2009/0317592 A1	12/2009	Yoshitomi et al.
6,522,460 B2	2/2003	Bonnedal et al.	2010/0224437 A1	9/2010	Booth et al.
6,522,760 B2	2/2003	Azima et al.	2010/0322455 A1	12/2010	Carlson
6,570,299 B2	5/2003	Takeshima et al.	2011/0026757 A1	2/2011	Takahashi et al.
6,617,765 B1	9/2003	Lagier et al.	2011/0033074 A1	2/2011	Chang et al.
6,708,797 B2	3/2004	Long et al.	2011/0044476 A1	2/2011	Burlingame et al.
6,720,708 B2	4/2004	Athanas	2011/0274283 A1	11/2011	Athanas
6,720,709 B2	4/2004	Porat et al.	2012/0186903 A1	7/2012	Booth et al.
6,785,393 B2	8/2004	Lipponen et al.			
6,797,396 B1	9/2004	Liu et al.			
6,844,657 B2	1/2005	Miller et al.			
6,845,166 B2	1/2005	Hara et al.			
7,009,326 B1	3/2006	Matsuo et al.	CA	2396260 A1	7/2001
7,010,143 B2	3/2006	Kam	CA	2610483 A1	12/2006
7,015,624 B1	3/2006	Su et al.	EP	1395083 A2	3/2004
7,020,302 B2	3/2006	Konishi et al.	FR	2649575 A1	1/1991
7,038,356 B2	5/2006	Athanas	GB	1369241 A	10/1974
7,039,206 B2	5/2006	Mellow	JP	52045923	4/1977
7,050,600 B2	5/2006	Saiki et al.	JP	57181298	11/1982
7,120,263 B2	10/2006	Azima et al.	JP	58034699	3/1983
7,151,837 B2	12/2006	Bank et al.	JP	58182999	10/1983
7,174,025 B2	2/2007	Azima et al.	JP	63176098	7/1988
7,194,098 B2	3/2007	Azima et al.	JP	63176099	7/1988
7,212,648 B2	5/2007	Saiki et al.	JP	63250995	10/1988
7,236,602 B2	6/2007	Gustavsson	JP	6217296	8/1994
D548,796 S *	8/2007	Sachnoff D20/43	JP	8102988	4/1996
7,274,855 B2	9/2007	Nevo et al.	JP	9298798	11/1997
D561,172 S *	2/2008	Seo et al. D14/211	JP	10094093	4/1998
7,339,736 B2	3/2008	Trapani et al.	JP	10327491	12/1998
D576,683 S *	9/2008	Frey D20/10	JP	11215578	8/1999
7,536,211 B2	5/2009	Saiki et al.	JP	2000350285 A	12/2000
7,565,949 B2	7/2009	Tojo	JP	2000356808 A	12/2000
7,583,811 B2	9/2009	Wada	JP	2001320798 A	11/2001
7,788,808 B1	9/2010	Ptak	JP	2004147286 A	5/2004
7,792,319 B2	9/2010	Kimura et al.	JP	2005105892 A	4/2005
7,884,529 B2	2/2011	Johnson et al.	JP	4140999 B2	8/2008
7,889,601 B2	2/2011	Goodmote et al.	JP	2010283867 A	12/2010
7,903,091 B2	3/2011	Lee et al.	JP	2012134998 A	7/2012
D643,002 S *	8/2011	Choi et al. D14/126	JP	5122793 B2	1/2013
8,033,674 B1	10/2011	Coleman et al.	KR	2008-0080258 A	9/2008
8,068,635 B2	11/2011	Carlson et al.	WO	96/35313 A1	11/1996
8,189,851 B2	5/2012	Booth et al.	WO	97/09844 A1	3/1997
D662,649 S *	6/2012	Watson-Levack D26/118	WO	97/09846 A1	3/1997
			WO	98/10252 A2	3/1998

FOREIGN PATENT DOCUMENTS

WO	98/28942	A1	7/1998
WO	01/52400	A1	7/2001
WO	2004/030406	A1	4/2004
WO	2006/130731	A2	12/2006
WO	2006/130782	A2	12/2006
WO	2009/067669	A1	5/2009
WO	2009/151892	A1	12/2009

OTHER PUBLICATIONS

Rainhandler Aluminum Fascia, announced Jul. 2011, [online], site visited Aug. 15, 2015. Available from Internet, <URL: <http://www.homedepot.com>>.*

International Search Report and Written Opinion mailed on Jul. 18, 2014, for International Patent Application No. PCT/US14/28345, filed Mar. 14, 2014 (17 pages).

Backman, 1999, "Improving Piezoelectric Speakers with Feedback," Proc. AES Convention 106, 10 pages.

Beck, 2006, "Hysteresis Characterization Using Charge Feedback Control for a LIPCA Device," Proc. SPIE Int. Soc. For Opt. Eng. 6170, 10 pages.

Furutani, 1998, "Displacement control of piezoelectric element by feedback of induced charge," Nanotechnology 9:93-98.

Decision of Dismissal of Amendment in Japanese Patent Application No. 2007-066645, dated Sep. 27, 2011, 6 pages.

EPO Search Report for European App No. 01901776.3, dated Nov. 2, 2005, 5 pages.

EPO Supplementary Partial Search Report for European App No. 01901776.3, dated Apr. 26, 2005, 6 pages.

EPO Supplementary Search Report for European App No. 01901776.3, dated Aug. 3, 2005, 6 pages.

International Preliminary Examination Report for International Patent App PCT/US01/00349, dated Nov. 22, 2002, 4 pages.

International Preliminary Report on Patentability for International Patent App PCT/US06/21189, dated Dec. 6, 2007, 7 pages.

International Search Report and Written Opinion for International Patent App PCT/US01/00349, dated Apr. 30, 2001, 6 pages.

International Search Report and Written Opinion for International Patent App PCT/US06/21189, dated Nov. 21, 2006, 8 pages.

International Search Report and Written Opinion for International Patent App PCT/US06/21311, dated Sep. 5, 2007, 8 pages.

International Search Report and Written Opinion for International Patent App PCT/US08/184359, dated Jan. 27, 2009, 6 pages.

International Search Report and Written Opinion for International Patent App PCT/US09/44544, dated Nov. 13, 2009, 7 pages.

International Search Report and Written Opinion for International Patent App PCT/US10/45628, dated Oct. 6, 2010, 10 pages.

International Search Report and Written Opinion for International Patent App PCT/US11/44564, dated Oct. 31, 2011, 9 pages.

International Search Report for International Patent App PCT/GB97/03090, dated Jun. 9, 1998, 5 pages.

Azom.com, A to Z of Materials, Cellulose Acetate—CA, added May 7, 2001, available at <http://azom.com/article.aspx?ArticleID=383>, retrieved Mar. 16, 2012, 2 pages.

Edmund Optics Worldwide, "TECHSPEC Linear Polarizing Laminated Film," available at <http://www.edmundoptics.com/onlinecatalog/displayproduct.cfm?productID=1912>, retrieved Dec. 3, 2009, 2 pages.

Harris, 1997, "The distributed-mode loudspeaker (DML) as a broadband acoustic radiator," Audio Engineering Society Preprint 4526 (D-6); Presented at the 103rd Convention Sep. 26-29, 1997 New York, 5 pages.

International Standard, 2006, "Adhesives—Peel test for a flexible-bonded-to-rigid test specimen assembly—Part I: 90 degree peel" ISO Reference No. ISO/FDIS 8510-1:2006 (E), 14 pages.

Kugel, "Bimorph-based piezoelectric air acoustic transducer: model," Sensors and Actuators A: Physical 69(3): 234-42.

PolymerProcessing.com, Poly(ethylene terephthalate), copyrighted 2000, 2001, available at <http://www.polymerprocessing.com/polymers/PET.html>, retrieved Mar. 16, 2012, 2 pages.

The Engineering Toolbox, Elastic Properties and Young Modulus for some Materials, available at http://www.engineeringtoolbox.com/young-modulus-d_417.html, retrieved Mar. 16, 2012, 4 pages.

The Physics Classroom, "Light Waves and Color—Lesson 1, How do we know light behaves as a wave?" available at <http://www.physicsclassroom.com/Class/light/U12L1a.cfm>, retrieved Dec. 3, 2009, 2 pages.

* cited by examiner

Primary Examiner — Derrick Holland

Assistant Examiner — Janice Lim

(74) *Attorney, Agent, or Firm* — Brown Rudnick LLP

(57)

CLAIM

The ornamental design for a sound bar audio speaker, as shown and described.

DESCRIPTION

FIG. 1 is a front perspective view of embodiment one, of a sound bar audio speaker, showing my new design.

FIG. 2 is a front view thereof.

FIG. 3 is a back view thereof.

FIG. 4 is a left side view thereof.

FIG. 5 is a right side view thereof.

FIG. 6 is a top plan view thereof.

FIG. 7 is a bottom plan view thereof.

FIG. 8 is another front perspective view thereof.

FIG. 9 is another front view thereof.

FIG. 10 is another rear view thereof.

FIG. 11 is another right side view thereof.

FIG. 12 is another top plan view thereof.

FIG. 13 is another bottom plan view thereof.

FIG. 14 is a partially enlarged view thereof, taken along the lines 14 of FIG. 8.

FIG. 15 is a partially enlarged view thereof, taken along the lines 15 of FIG. 9.

FIG. 16 is a partially enlarged view thereof, taken along the lines 16 of FIG. 10.

FIG. 17 is a right side view thereof, shown in an enlarged scale, taken along the lines 17 of FIG. 11.

FIG. 18 is a partially enlarged view thereof, taken along the lines 18 of FIG. 12.

FIG. 19 is a partially enlarged view thereof, taken along the lines 19 of FIG. 13.

FIG. 20 is a front perspective view of embodiment two, of a sound bar audio speaker, showing my new design.

FIG. 21 is a front view thereof.

FIG. 22 is a back view thereof.

FIG. 23 is a left side view thereof.

FIG. 24 is a right side view thereof.

FIG. 25 is a top plan view thereof.

FIG. 26 is a bottom plan view thereof.

FIG. 27 is another front perspective view thereof.

FIG. 28 is another front view thereof.

FIG. 29 is another rear view thereof.

FIG. 30 is another right side view thereof.

FIG. 31 is another top plan view thereof.

FIG. 32 is another bottom plan view thereof.

FIG. 33 is a partially enlarged view thereof, taken along the lines 33 of FIG. 27.

FIG. 34 is a partially enlarged view thereof, taken along the lines 34 of FIG. 28.

FIG. 35 is a partially enlarged view thereof, taken along the lines 35 of FIG. 29.

FIG. 36 is a right side view thereof, shown in an enlarged scale, taken along the lines 36 of FIG. 30.

FIG. 37 is a partially enlarged view thereof, taken along the lines 37 of FIG. 31; and,

FIG. 38 is a partially enlarged view thereof, taken along the lines 38 of FIG. 32.

The broken line portions of FIGS. 1-38 are included to show unclaimed subject matter only and form no part of the claimed design.

The dot-dash broken line portions of FIGS. 8-16, 18, 19, 27-35, 37, and 38 are included to show partly enlarged views only and form no part of the claimed design.

1 Claim, 24 Drawing Sheets

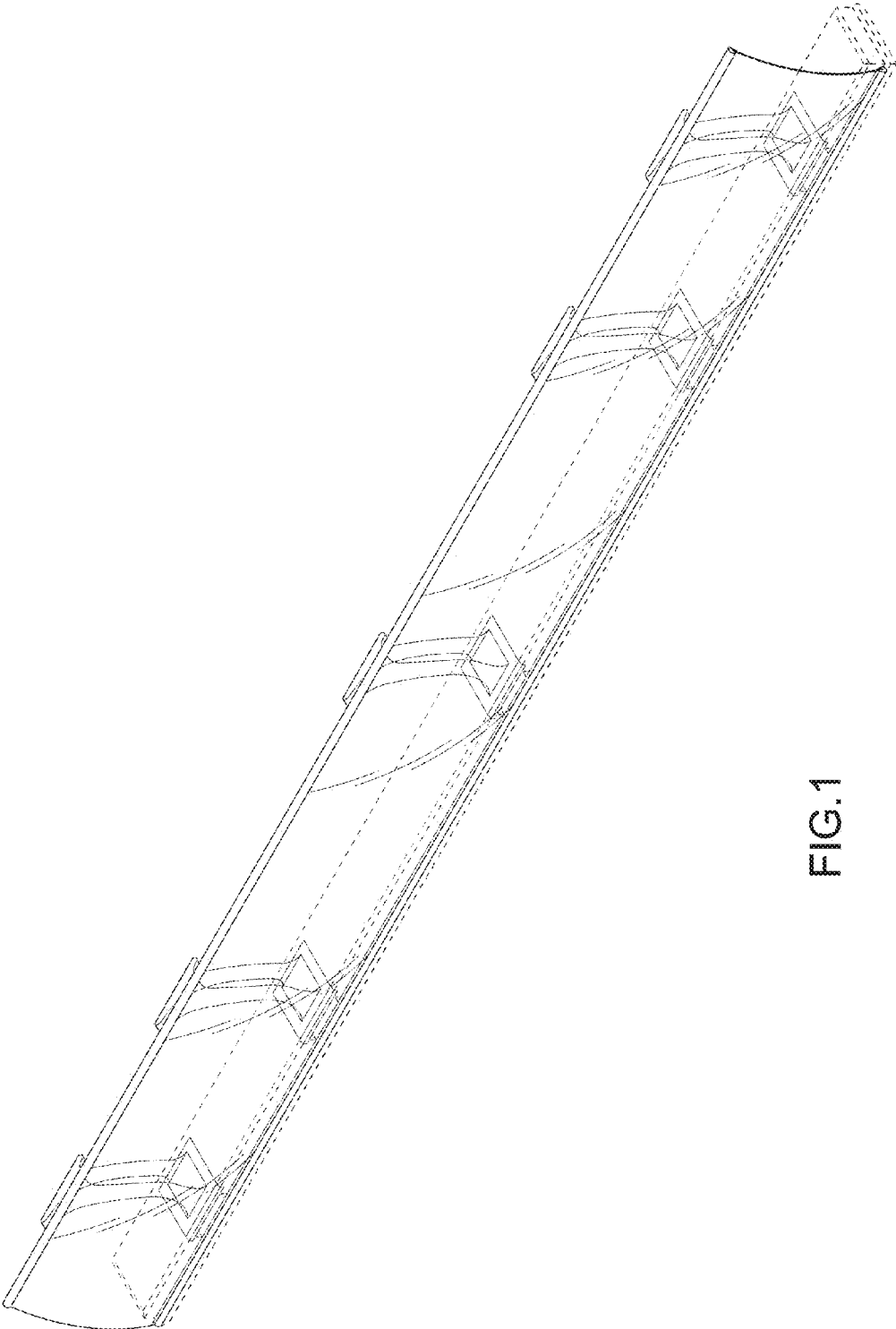

FIG.1

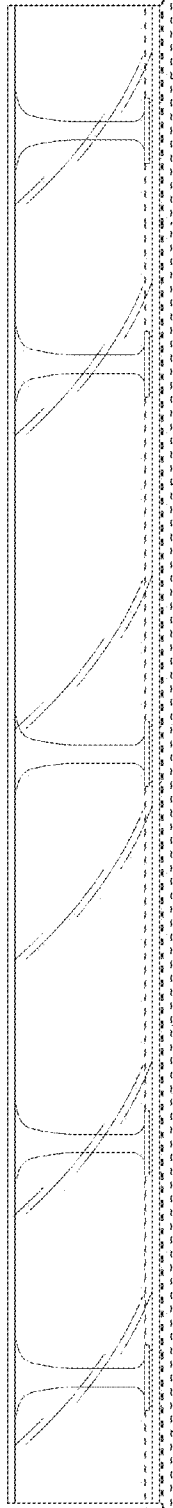

FIG. 2

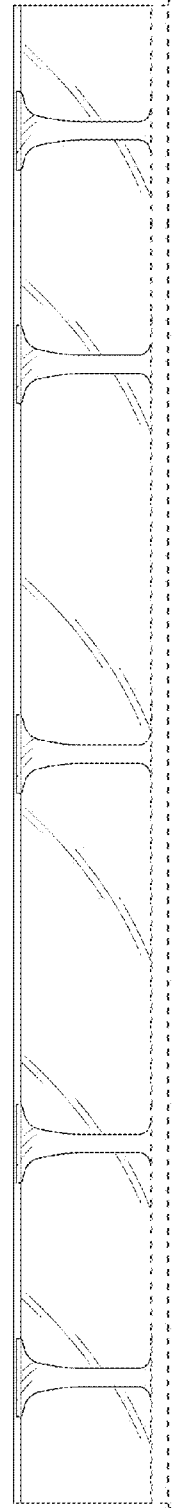

FIG. 3

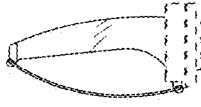

FIG.5

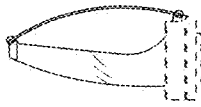

FIG.4

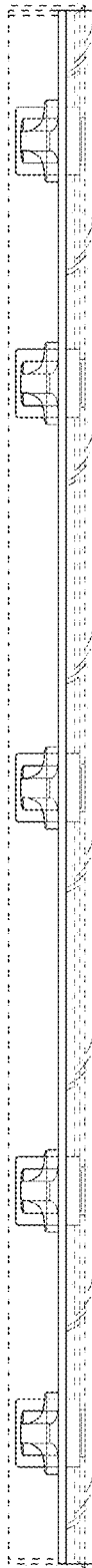

FIG. 6

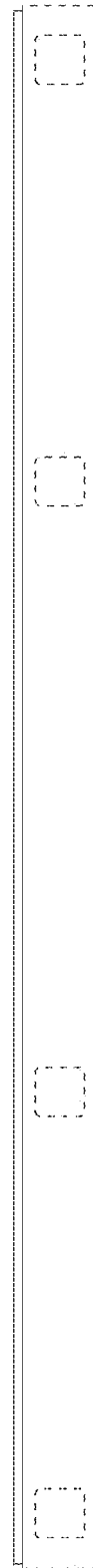

FIG. 7

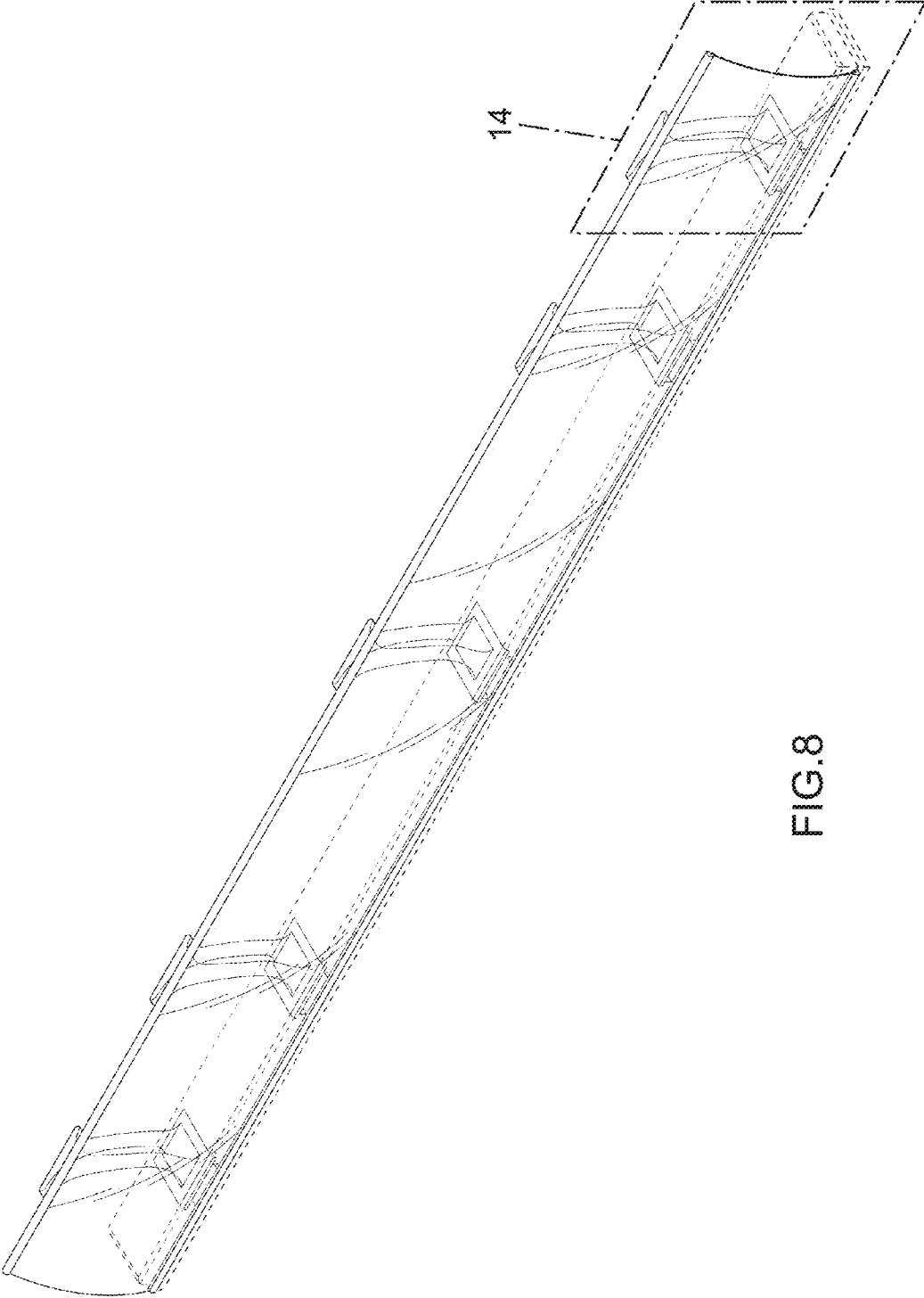
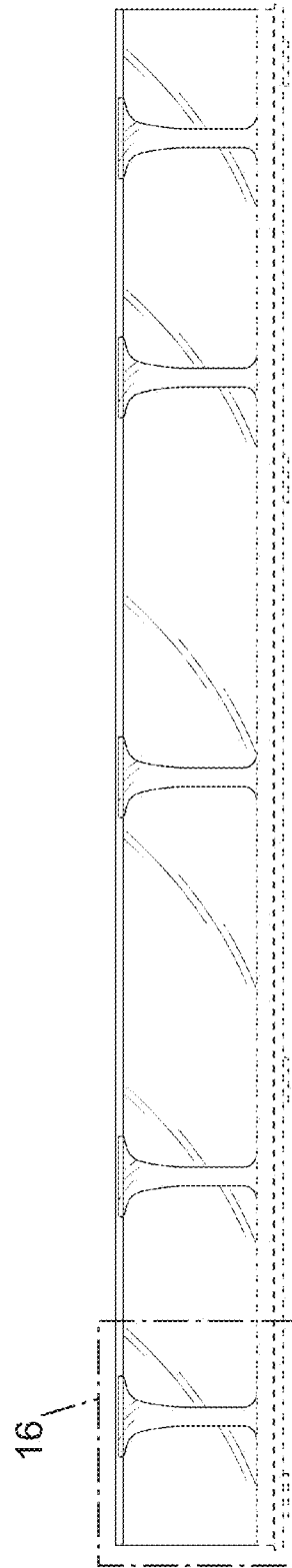
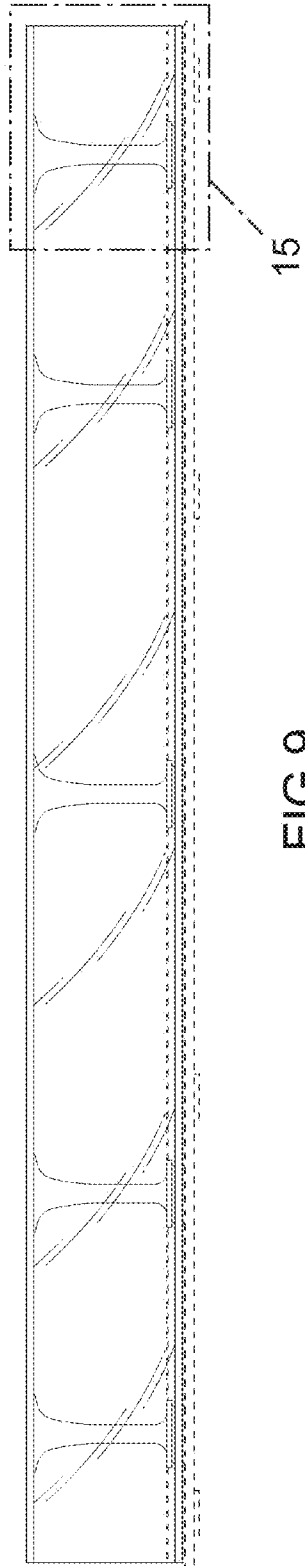

FIG.8



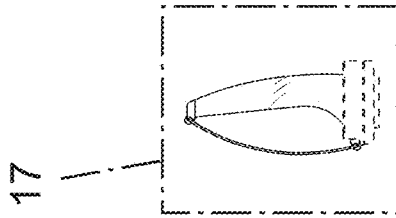

FIG. 11

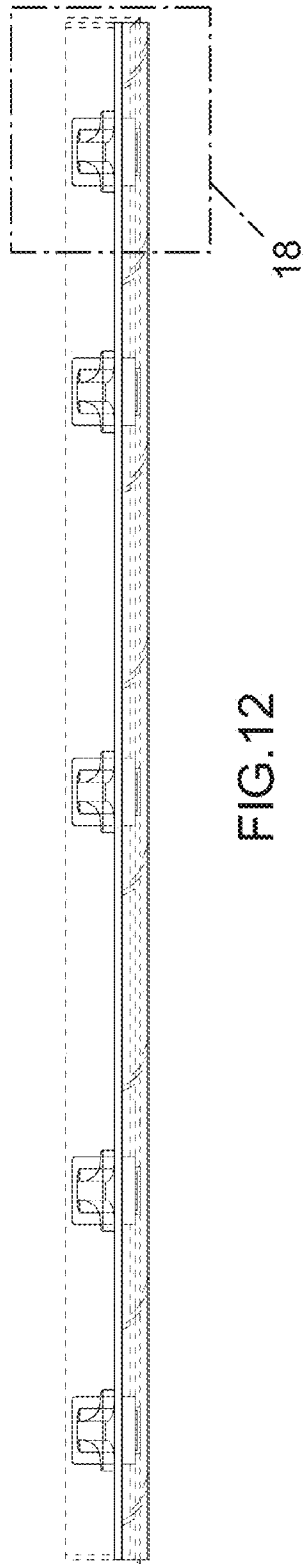

FIG. 12

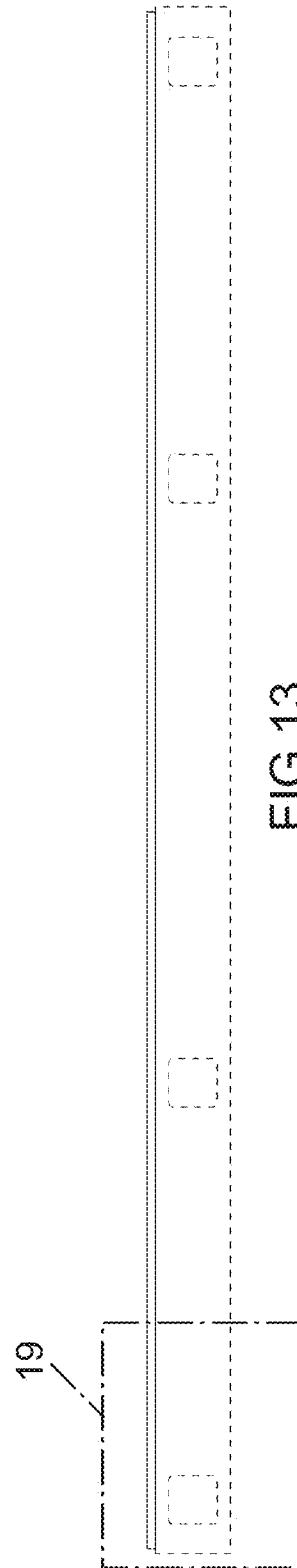

FIG. 13

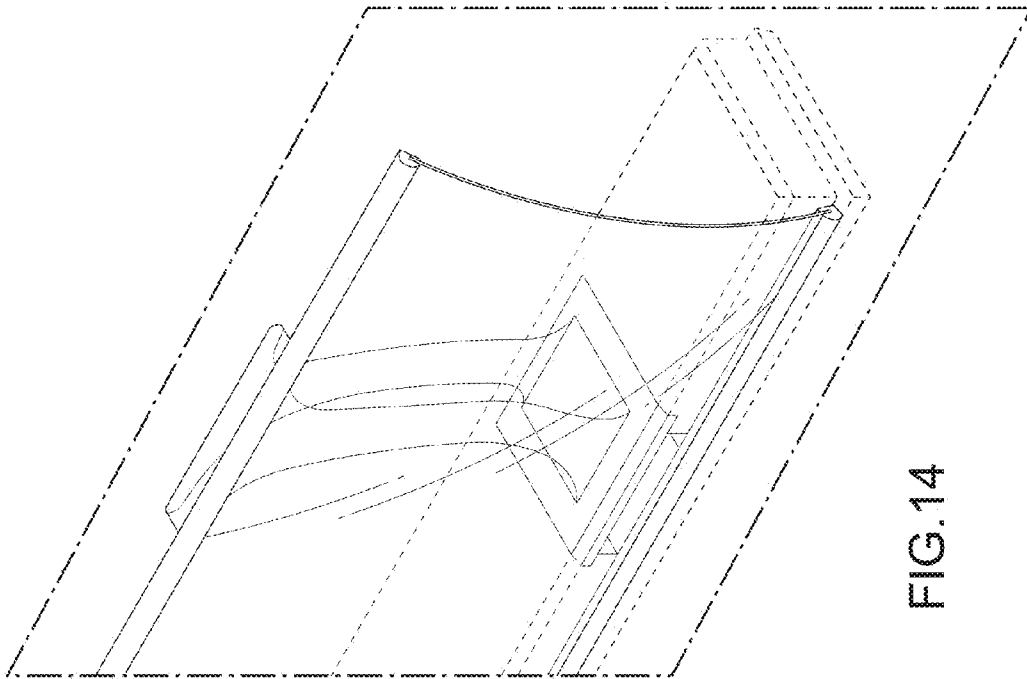

FIG.14

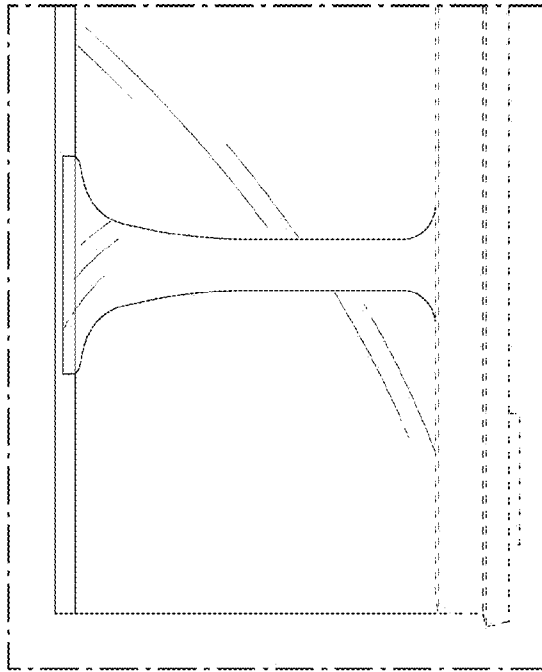

FIG. 15

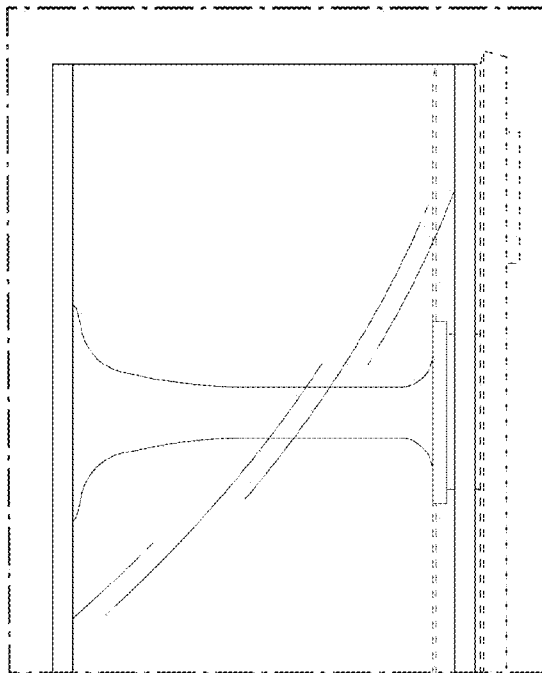

FIG. 16

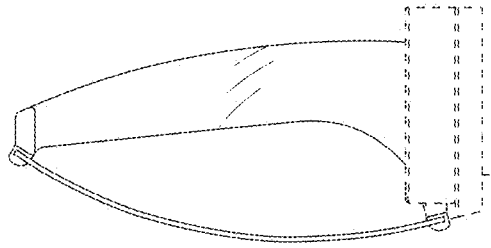

FIG.17

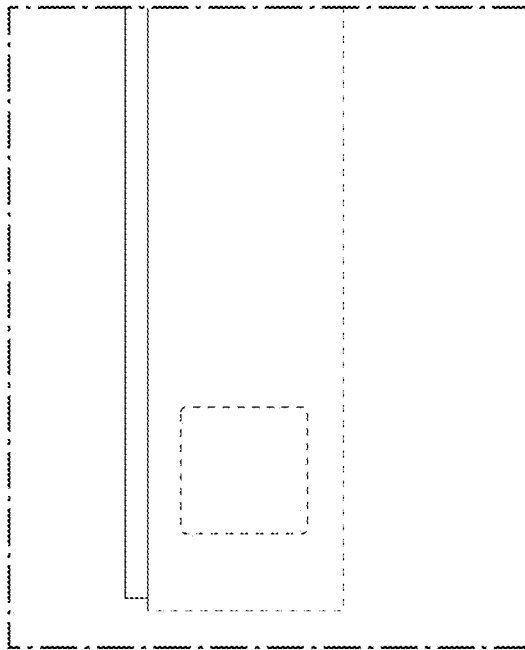

FIG.19

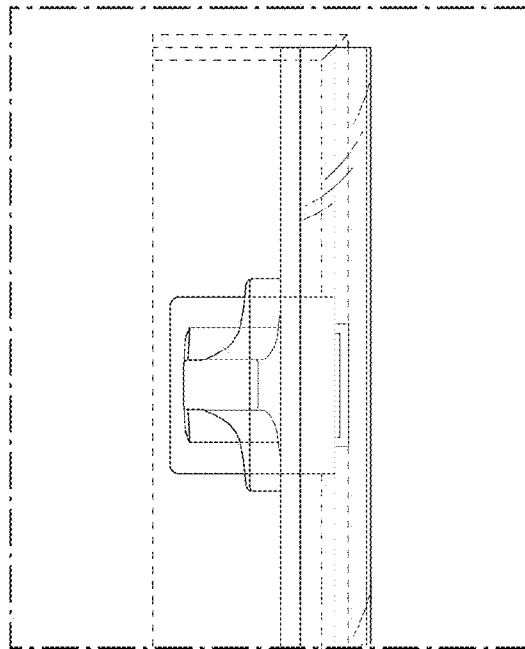

FIG.18

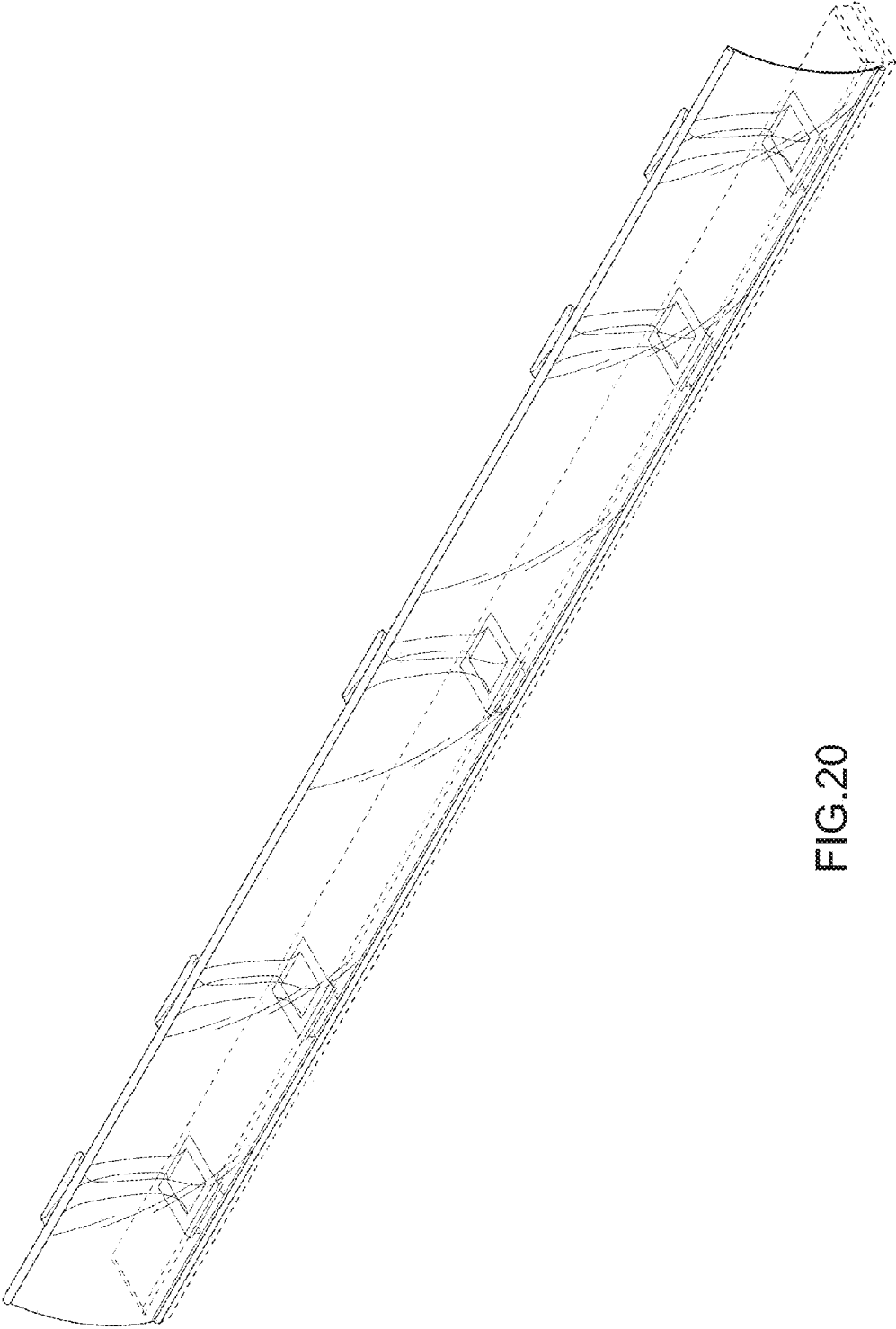

FIG.20

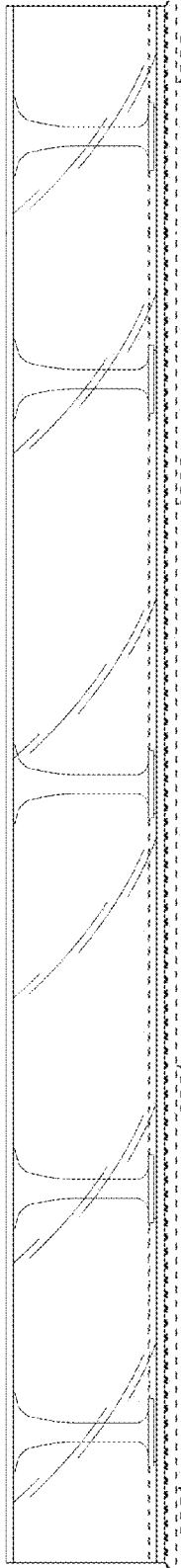

FIG. 21

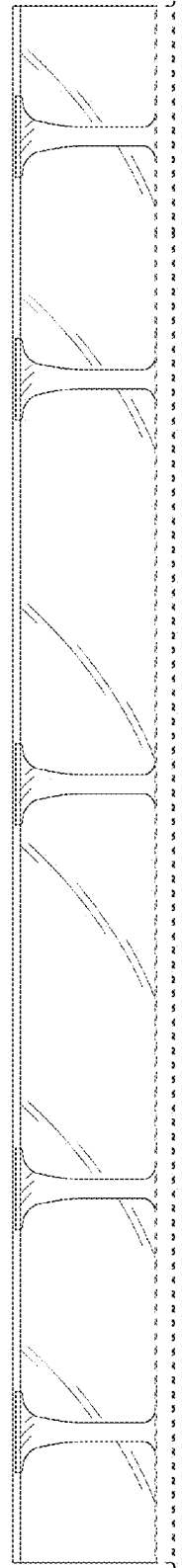

FIG. 22



FIG.24

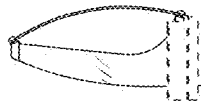

FIG.23

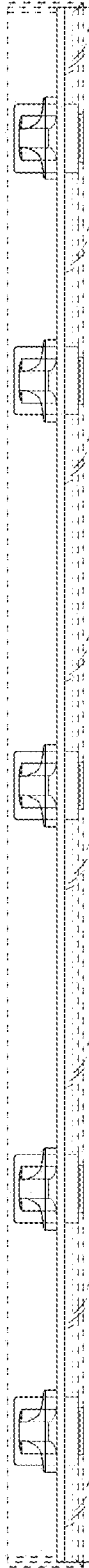

FIG. 25



FIG. 26

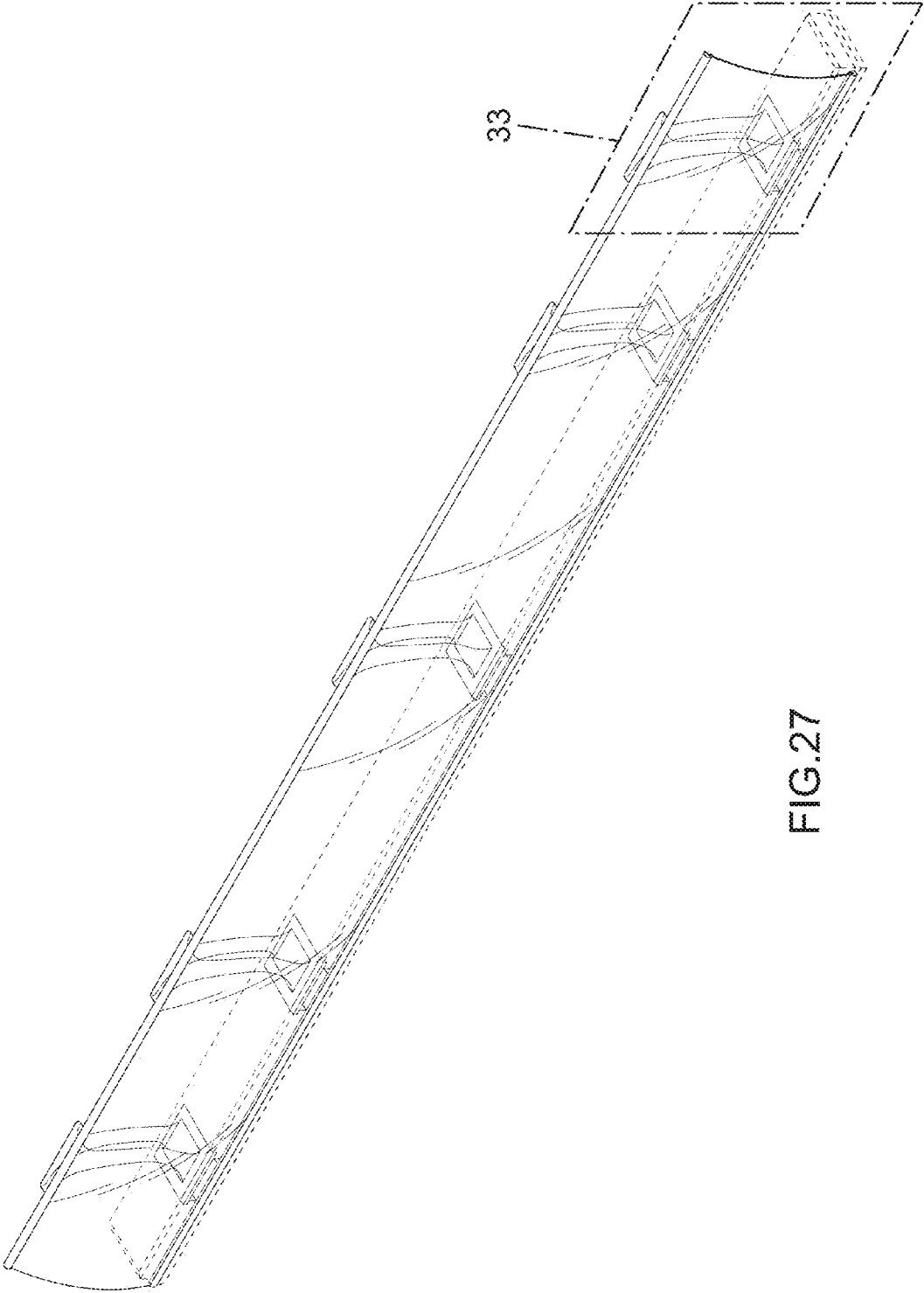

FIG.27

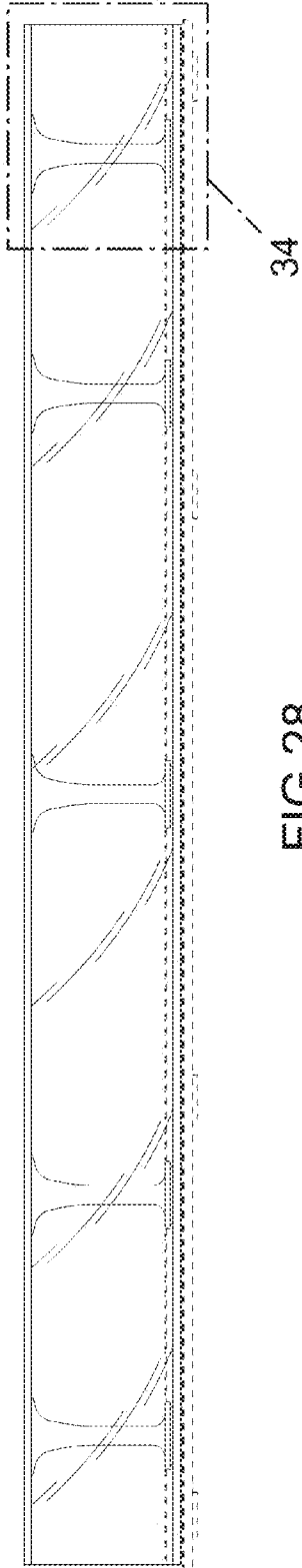

FIG. 28

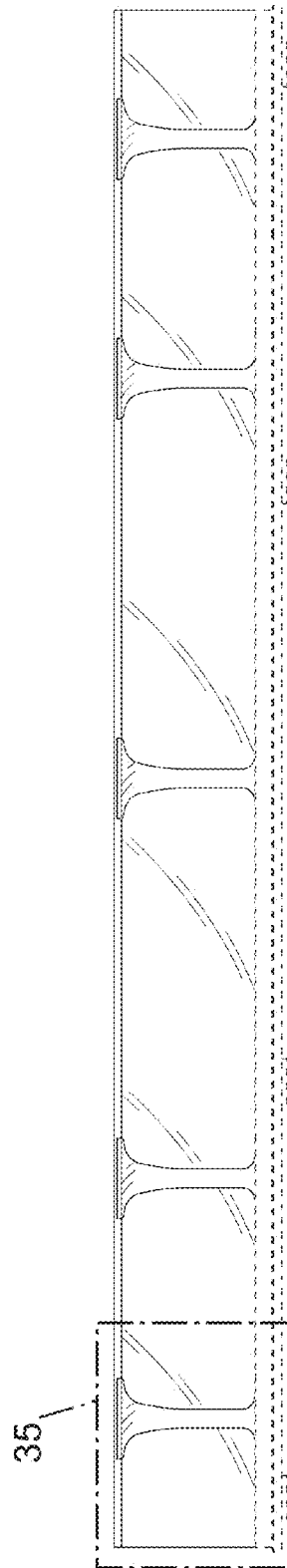

FIG. 29

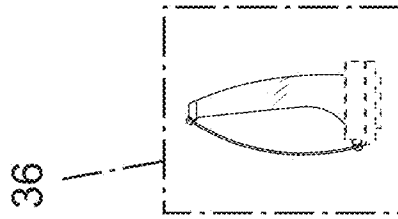

FIG.30

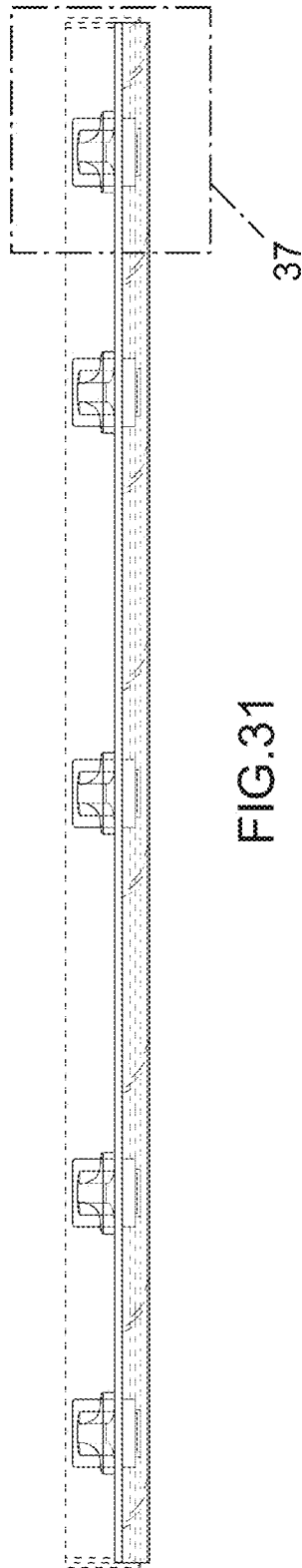

FIG. 31

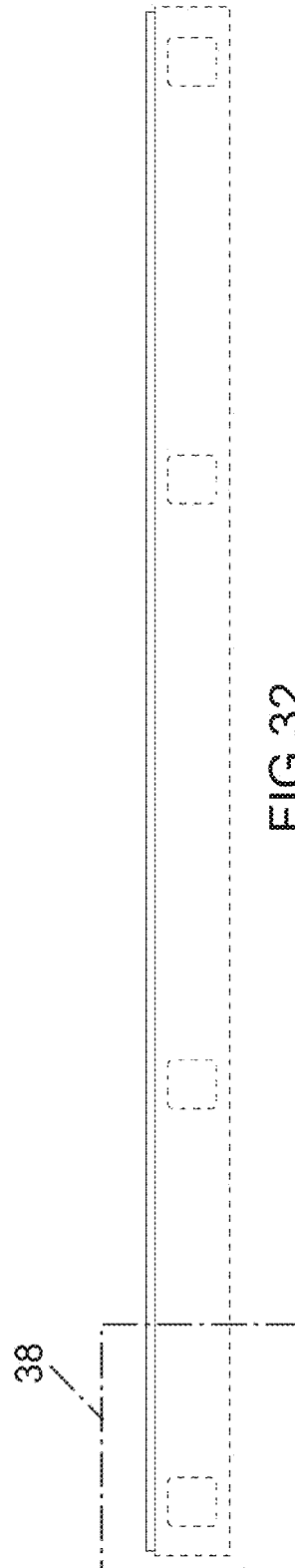

FIG. 32

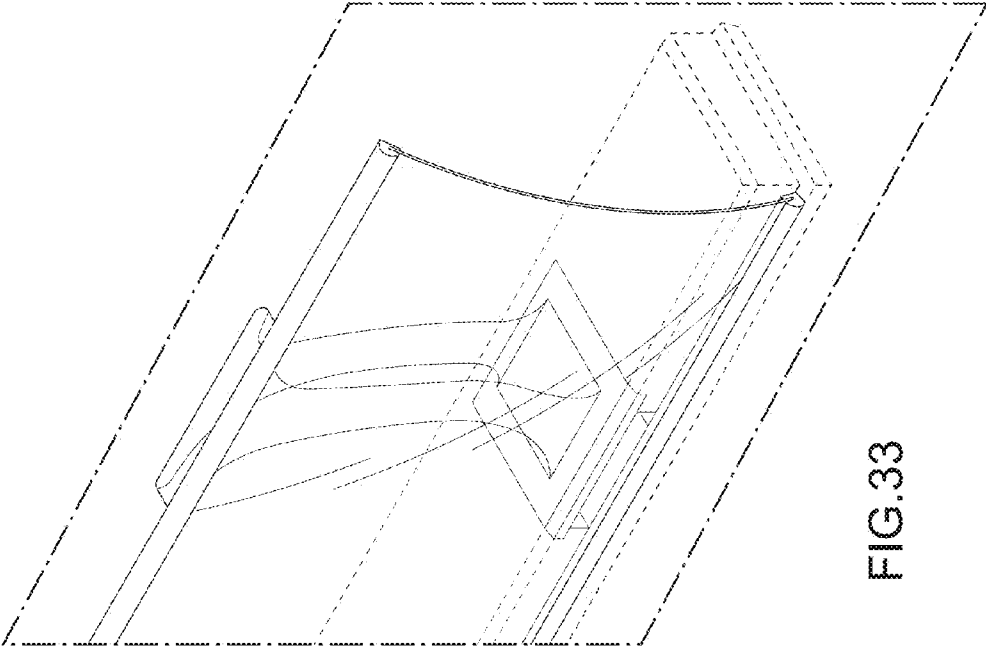

FIG.33

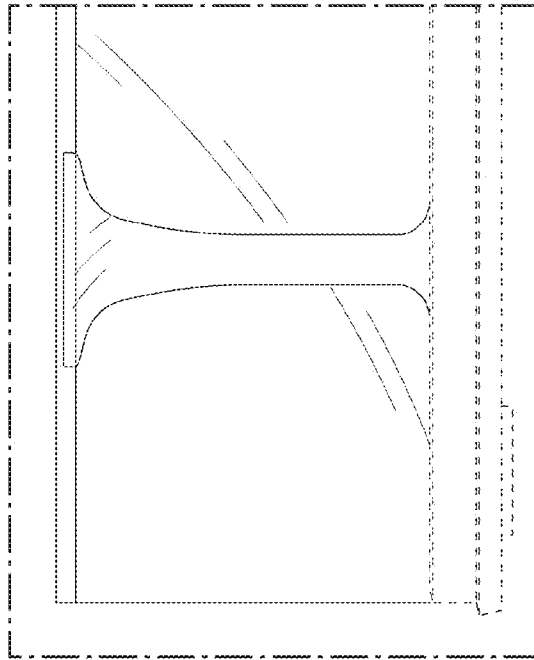

FIG.35

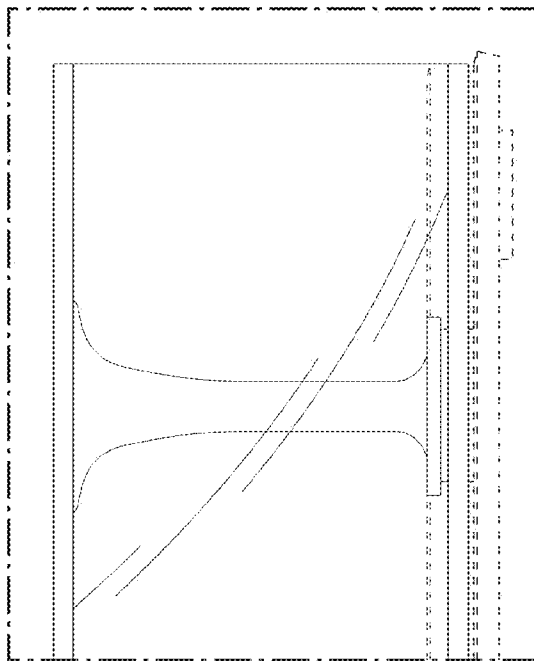

FIG.34

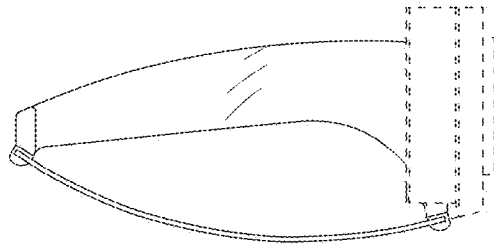

FIG.36

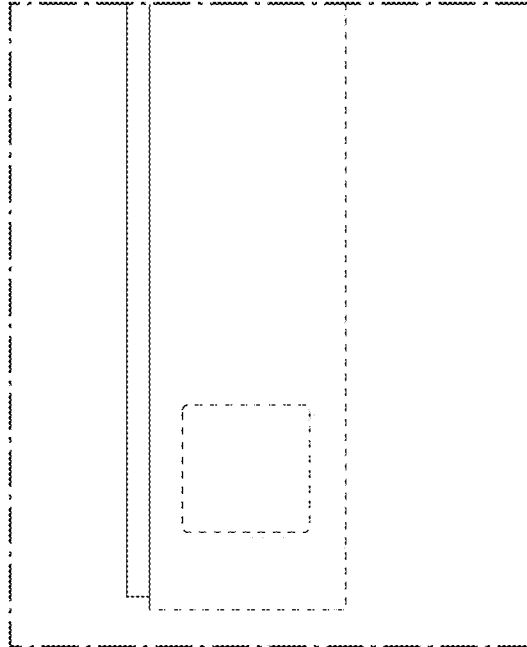

FIG.38

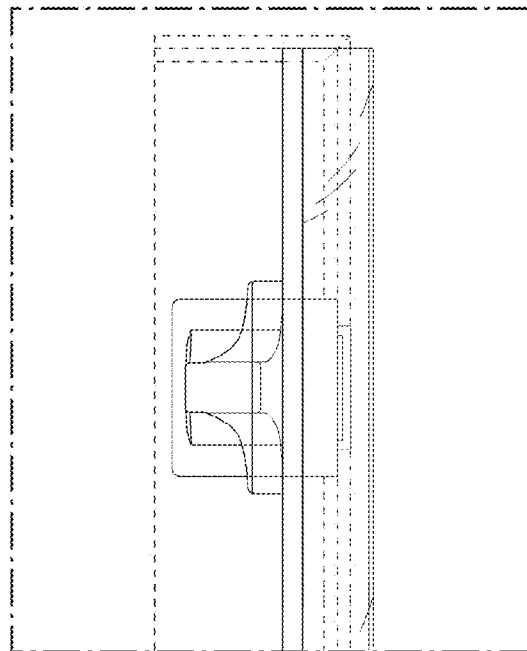

FIG.37