

(19)



(11)

**EP 2 953 498 B1**

(12)

**EUROPEAN PATENT SPECIFICATION**

(45) Date of publication and mention of the grant of the patent:  
**26.04.2017 Bulletin 2017/17**

(51) Int Cl.:  
**A44C 11/00 (2006.01)**

(21) Application number: **14703766.7**

(86) International application number:  
**PCT/DK2014/050024**

(22) Date of filing: **03.02.2014**

(87) International publication number:  
**WO 2014/121798 (14.08.2014 Gazette 2014/33)**

**(54) ORNAMENTAL COMPONENT WITH GRIPPING ELEMENT**

SCHMUCKKOMPONENTE MIT AUSKLEIDUNG

COMPOSANT DÉCORATIF COMPORTANT UN REVÊTEMENT

(84) Designated Contracting States:  
**AL AT BE BG CH CY CZ DE DK EE ES FI FR GB GR HR HU IE IS IT LI LT LU LV MC MK MT NL NO PL PT RO RS SE SI SK SM TR**

(72) Inventors:  
 • **GRAY, Lee Antony**  
**DK-2100 København Ø (DK)**  
 • **SELBE, Jean-Pierre**  
**10250 Bangkok (TH)**  
 • **WEERASAK, Wannachai**  
**10250 Bangkok (TH)**

(30) Priority: **11.02.2013 EP 13154844**  
**11.02.2013 EP 13154843**  
**11.02.2013 US 201361763251 P**

(74) Representative: **Awapatent A/S**  
**Strandgade 56**  
**1401 Copenhagen K (DK)**

(43) Date of publication of application:  
**16.12.2015 Bulletin 2015/51**

(56) References cited:  
**DE-U1- 20 021 250 JP-A- 2005 143 851**  
**US-A1- 2006 277 945**

(73) Proprietors:  
 • **Pandora A/S**  
**1561 København V (DK)**  
 • **Pandora Production Co., Ltd.**  
**Bangkok 10250 (TH)**

Note: Within nine months of the publication of the mention of the grant of the European patent in the European Patent Bulletin, any person may give notice to the European Patent Office of opposition to that patent, in accordance with the Implementing Regulations. Notice of opposition shall not be deemed to have been filed until the opposition fee has been paid. (Art. 99(1) European Patent Convention).

**EP 2 953 498 B1**

**Description****Field**

**[0001]** The present invention relates to an ornamental component for a bracelet or necklace, to a bracelet or necklace comprising such an ornamental component, to a method of manufacturing an ornamental component, and a tubular element for securing a gripping element inside a through hole of an ornamental component.

**Background**

**[0002]** Jewellery, such as necklaces and bracelets, often consists of a plurality of freely movable ornamental components e.g. beads strung on an elongated member e.g. chain, wire, or string. To prevent all the freely movable beads from grouping together at the bottom of the necklace or bracelet, an ornamental component provided with a stopping mechanism configured to grip the necklace or bracelet may be used. Such stopping mechanisms are known from the prior art in a variety of forms.

**[0003]** An example of a prior art variation of a stopping mechanism is disclosed in US 2003/0154742, in which a jewel is produced with an elastic body inside configured to provide a frictional force on an elongated member. A similar solution is disclosed in US 2002/0148250, in which the jewel itself is provided with a flexible resilient tube with an inside diameter slightly smaller than the outer diameter of an elongated member, as to fix said jewel on said elongated member.

**[0004]** US 2006/0277945 discloses a necklace or bracelet comprising links, that are formed by a set of parts including at least two caps including, on the one hand, means for assembling their feet to hold, between their heads a decorative casing element, and on the other hand, locking means at the junction of their feet for immobilising each link on the connecting member.

**[0005]** Another prior art variation is disclosed in WO 2006/125155.

**[0006]** It may, however, be difficult to produce such prior art ornamental components. Additionally, the stopping mechanisms may be vulnerable to damage.

**[0007]** Thus, it remains a problem to provide a robust ornamental component provided with a stopping mechanism that can be easily manufactured.

**Summary**

**[0008]** According to a first aspect, the invention relates to an ornamental component for a bracelet and / or a necklace, said ornamental component having a through hole allowing said ornamental component to be strung on an elongated member of a bracelet and / or necklace, said through hole defining a through hole axis; said ornamental component comprising:

- a self-supporting housing having a through hole

comprising a first opening at a first side of the self-supporting housing and a second opening at a second side of the self-supporting housing; and

- an insert assembly inserted in said through hole of said self-supporting housing;

wherein said insert assembly is assembled from a first tubular element having a through hole that forms at least a part of said through hole of said ornamental component and a gripping element for frictionally gripping a part of said bracelet and / or necklace; wherein said first tubular element is configured to secure said gripping element inside said through hole of said ornamental component, said first tubular element comprises a first circumferential opening extending along the through hole axis, and wherein said gripping element comprises a first gripping portion for frictionally gripping said elongated member of said bracelet and / or necklace, wherein said first gripping portion extends through said first circumferential opening.

**[0009]** Consequently, by using an insert assembly to provide an ornamental component with a gripping element, the production costs may be lowered. Additionally, by using a tubular element to secure the gripping element inside the self-supporting housing, the gripping element may be more efficiently protected from damage.

**[0010]** An ornamental component may be any component that can be strung on a bracelet and / or necklace for ornamental purposes such as a bead. An ornamental component according to the first aspect of the invention may be used to organize freely movable beads on a bracelet or necklace, e.g. two ornamental components may be pulled to a desired position on an elongated member of a bracelet or necklace and released, whereby they resiliently grip the elongated member. Consequently, the bracelet or necklace is divided into three distinct zones for freely movable beads. This may be used to prevent all the freely movable beads from grouping together.

**[0011]** The self-supporting housing may constitute the outer surface of the ornamental component or may be covered with another layer or element constituting the outer surface of the ornamental component. The self-supporting housing may have any shape such as approximately spherical, cylindrical or cubical. The self-supporting housing has a structural strength allowing it to be securely handled during the manufacturing process of the ornamental component. The self-supporting housing may provide the primary structural strength of the ornamental component. The self-supporting housing may be made of metal, glass, wood, plastic or a combination thereof. The through hole of the self-supporting housing may have a constant width or may have a varying width (measured in planes being perpendicular to the through hole axis), e.g. the through hole of the self-supporting housing may be wider in the central part of self-supporting housing than at the first opening and the second opening. The inner surface of the through hole of the self-supporting housing may be spaced apart from the insert assembly.

bly by another element or a fluid e.g. air. At least a part of the self-supporting housing may be transparent or semi-transparent.

**[0012]** The individual element of the insert assembly may be permanently attached or non-permanently attached. The insert assembly may be inserted into the through hole of the housing through the first opening of the housing, i.e. the insert assembly may have a size and shape allowing it to be insertable through the first opening of the self-supporting housing.

**[0013]** The first tubular element may have any outer shape such as round or rectangular. Correspondingly, the through hole of the first tubular element may have any shape such as round or rectangular. The first tubular element may be integrally molded, i.e. made from a single mold. The first tubular element may be made of metal and / or plastic.

**[0014]** The gripping element may be made of a material configured to establish a high frictional connection with an elongated member or a bracelet and / or necklace, e.g. a chain, band, or strand of a necklace or bracelet. The gripping element may be made of a deformable material such as a silicone material.

**[0015]** In some embodiments, said gripping element is made of a first material and said first tubular element is made of a second material, wherein said coefficient of friction of said first material is higher than said coefficient of friction of said second material relative to sterling silver.

**[0016]** The coefficient of friction of the first material may be at least 10%, 20%, 40% or 60% higher than the coefficient of friction of the second material relative to sterling silver.

**[0017]** In some embodiments of the invention, the gripping element is positioned in a central part of the ornamental component and have a width along the through hole axis of less than 95%, 90%, 80%, 70%, 60% or 50% of the width of the self-supporting housing along the through hole axis.

**[0018]** Consequently, the gripping element is better protected. Thus, a more robust ornamental component is provided.

**[0019]** In some embodiments, said gripping element comprises a tubular portion, said first gripping portion protrudes from an interior surface of said tubular portion, and wherein said tubular portion of said gripping element surrounds a part of said first tubular element.

**[0020]** Consequently, said tubular element may in an efficient manner secure said gripping element inside said through hole of said ornamental component.

**[0021]** The entire gripping element may be integrally molded, i.e. made from a single mold.

**[0022]** In some embodiments, said first tubular element comprises a second circumferential opening extending along the through hole axis and said gripping element comprises a second gripping portion protruding from an interior surface of said tubular portion of said gripping element, wherein said second gripping portion extends through said second circumferential opening.

**[0023]** In some embodiments, said first tubular element comprises a third circumferential opening extending along the through hole axis and said gripping element comprises a third gripping portion protruding from an interior surface of said tubular portion of said gripping element, and wherein said third gripping portion extends through said third circumferential opening.

**[0024]** In some embodiments, the first circumferential opening, the second circumferential opening and / or the third circumferential opening have a width along the through hole axis of less than 95%, 90%, 80%, 70%, 60% or 50% of the width of the first tubular element along the through hole axis.

**[0025]** In some embodiments, each of the first circumferential opening, the second circumferential opening and / or the third circumferential opening extends between 5% and 33% of the circumference of the first tubular element in a plane being perpendicular to the through hole axis.

**[0026]** In some embodiments, the first tubular element comprises a first portion and a second portion, wherein the second portion has a lower widest width than the widest width of the first portion, and wherein the tubular portion of the gripping element is arranged to fit snugly around the second portion of the first tubular element, and abutting the first portion of the first tubular element whereby the gripping element is prevented from moving in a first direction along the through hole axis relative to the first tubular element.

**[0027]** In some embodiments, the first tubular element further comprises a third portion, and wherein the second portion has a lower widest width than the widest width of the first portion and the third portion, and wherein the tubular portion of the gripping element further abuts the third portion of the first tubular element thereby preventing the gripping element from moving in any direction along the through hole axis relative to the first tubular element.

**[0028]** The widest width is measured in a plane being perpendicular to the through hole axis.

**[0029]** In some embodiments, said tubular portion of said gripping element has a widest width approximately equal to the widest width of the first portion and / or third portion of the first tubular element.

**[0030]** In some embodiments, the ornamental component further comprises a second tubular element, and wherein said first tubular element is positioned inside said second tubular element,

**[0031]** This may make it easier to insert the insert assembly into the self-supporting housing. The second tubular element may additionally hide non-decorative elements of the ornamental component, when the self-supporting housing is transparent or semi-transparent.

**[0032]** The second tubular element may have a width along the through hole axis being approximately equal to the width of the self-supporting housing. The second tubular element may be fully inserted into the through hole of the self-supporting housing.

**[0033]** In some embodiments, said first tubular element of said insert assembly at a first end further comprises a collar, wherein said collar is positioned outside said self-supporting housing at the first opening of said self-supporting housing and comprises a surface abutting an outer surface of said self-supporting housing thereby preventing said first tubular element of said insert assembly from moving in a first direction along said through hole axis relative to said ornamental component.

**[0034]** The outer surface may be an outer surface of said self-supporting housing. The collar may be an integral portion of the first tubular element or may be attached to the first tubular element.

**[0035]** In some embodiments, said ornamental component further comprises a locking element having a through hole wherein said locking element comprises an engagement portion positioned inside said self-supporting housing and a collar positioned outside said self-supporting housing, wherein said engagement portion is attached to said first tubular element and said collar comprises a surface abutting an outer surface of said self-supporting housing thereby preventing said first tubular element of said insert assembly from moving in a second direction along said through hole axis relative to said ornamental component.

**[0036]** Consequently, the insert assembly is in an effective manner secured to the self-supporting housing.

**[0037]** The outer surface may be an outer surface of said self-supporting housing.

**[0038]** The engagement portion and the collar of the locking element may be integrally formed. The locking element may be attached to the first tubular element by the use of glue or a mechanical locking mechanism.

**[0039]** In some embodiments, said engagement part of said locking element is inserted into said first tubular element whereby said through hole of said locking element and said through hole of said first tubular element together forms the through hole of said ornamental component.

**[0040]** In some embodiments, said engagement portion is attached to said first tubular element by a male / female locking mechanism, wherein the male part comprises a protruding portion and the female part comprises a recess and / or opening.

**[0041]** The engagement portion may be the male part and the first tubular element may be the female part, i.e. the engagement portion may comprise a protruding portion configured to engage with recess and / or opening in the first tubular element. Alternatively, the first tubular element may be the male part and the engagement portion may be the female part.

**[0042]** In some embodiments, the male / female locking mechanism is of the snap lock type wherein a translation and / or rotation from a free rotational orientation and / or position of the male and female part to a locked rotational orientation and / or position of the male and female part requires less force than a translation and /

or rotation from a locked rotational orientation and / or position of the male and female part to a free rotational orientation and / or position of the male and female part.

**[0043]** This may be beneficial as the locking element and the first tubular element typically are permanently attached.

**[0044]** In some embodiments, the male / female locking mechanism may be of the rotational lock type, wherein the female part (the engagement portion or the first tubular element) comprises a recess and / or opening configured to allow the protruding portion of the male part to translate inside the recess and / or opening along the through hole axis when the locking element is in a free rotational orientation relative to the first tubular element, and to be prevented from moving in at least a first direction along the through hole axis when the locking element is in a locked position relative to the first tubular element and the locking element is in a locked rotational orientation relative to the first tubular element.

**[0045]** In some embodiments, the male part comprises a plurality of protruding portions and the female part comprises a plurality of recess and / or openings.

**[0046]** When the male / female locking mechanism is of the rotational type the locking element may be attached to the first tubular element by firstly rotationally orienting the locking element in the free rotational orientation relative to the first tubular element, next translating the first tubular element and / or the locking element along the through hole axis until the locking element is in the locked position relative to the first tubular element, and finally rotating the first tubular element and / or the locking element from the free rotational orientation to the locked rotational orientation.

**[0047]** The protruding portion of the male part and / or the recess and / or opening of the female part may be configured so that a rotation from the free rotational orientation to the locked rotational orientation requires less force than a rotation from the locked rotational orientation to the free rotational orientation.

**[0048]** In some embodiments, the male part (the engagement portion or the first tubular element) comprises a flexible member configured to deform from a first shape to a second shape when the male part comes into contact with the female part, and further to snap back into approximately the first shape when the flexible member is aligned with the recess and / or opening of the female part, whereby the flexible member engages with the recess and / or opening and locks the male part to the female part, allowing the locking element to be attached to the first tubular element by a pure translation between the two.

**[0049]** In some embodiments, the male part comprises two flexible members, and the female part comprises two recesses and / or openings.

**[0050]** The two flexible members may be arranged at opposite sides of the male part. Correspondingly, the two recesses and / or openings may be arranged at opposite sides of the female part.

**[0051]** In some embodiments, the ornamental component has a length along the through hole axis between 2 mm and 5 cm.

**[0052]** In some embodiments, said first tubular element comprises a fourth circumferential opening extending along the through hole axis and said gripping element comprises a fourth gripping portion protruding from an interior surface of said tubular portion of said gripping element, and wherein said fourth gripping portion extends through said fourth circumferential opening.

**[0053]** According to a second aspect, the invention relates to a bracelet or a necklace comprising:

- an elongated member; and
- a first ornamental component as disclosed in relation to the first aspect of the invention, strung on said elongated member;

wherein the first ornamental component is configured so that the gripping element resiliently grips the elongated member to fix the first ornamental component along the elongated member until a particular force is acting on said first ornamental component, whereby the first ornamental component can be moved along the elongated member.

**[0054]** The elongated member may be any elongated member suitable for jewellery such as a metal chain, leather string, a fabric string, or an anchor type chain.

**[0055]** In some embodiments, the particular force is higher than the maximum gravitational force gravity acting on the ornamental component.

**[0056]** In some embodiments, the bracelet or necklace further comprises at least one freely movable ornamental component strung on said elongated member.

**[0057]** In some embodiments, the bracelet or necklace further comprises a plurality of freely movable ornamental components strung on said elongated member.

**[0058]** In some embodiments, the bracelet or necklace further comprises a second ornamental component as disclosed in relation to the first aspect of the invention strung on said elongated member; wherein the second ornamental component is configured so that the gripping element resiliently grips the elongated member to fix the second ornamental component along the elongated member until a particular force is acting on said second ornamental component, whereby the second ornamental component can be moved along the elongated member.

**[0059]** According to a third aspect, the invention relates to a method for manufacturing an ornamental component, said ornamental component having a through hole allowing said ornamental component to be strung on an elongated member of a bracelet and / or necklace, said through hole defining a through hole axis, comprising the steps of:

- providing a self-supporting housing, having a through hole, wherein said through hole comprises a first opening at a first side of the self-supporting

housing and a second opening at a second side of the self-supporting housing;

- assembling an insert assembly comprising a first tubular element having a through hole that at least partly forms said through hole of said ornamental component, and a gripping element for frictionally gripping said elongated member of a bracelet and / or a necklace; and
- inserting said insert assembly in said through hole of said housing,

wherein said first tubular element comprises a first circumferential opening extending along the through hole axis, and wherein said gripping element comprises a first gripping portion, for frictionally gripping said elongated member of said bracelet and / or necklace, and a tubular portion, wherein said first gripping portion is protruding from an inner surface of said tubular portion, and wherein the step of assembling said insert assembly comprises pulling said gripping element around said first tubular element until said first gripping portion is aligned with said first circumferential opening, whereby said first gripping portion extends through said first circumferential opening and a part of said inner surface of said tubular portion rests upon a part of the outer surface of said first tubular element thereby securing said gripping element to said first tubular element.

**[0060]** Consequently, an efficient method of producing an ornamental component comprising a gripping element is provided.

**[0061]** In some embodiments, the insert assembly is inserted in said through hole of said self-supporting housing through said first opening of said self-supporting housing.

**[0062]** In some embodiments, the ornamental component is an ornamental component as disclosed in relation to the first aspect of the invention.

**[0063]** In some embodiments, said insert assembly is assembled before it is inserted into said through hole of said self-supporting housing.

**[0064]** In some embodiments, said first tubular element further comprises a second circumferential opening extending along the through hole axis, and wherein said gripping element further comprises a second gripping portion for frictionally gripping said elongated member of said bracelet and / or necklace, wherein said second gripping portion is protruding from an inner surface of said tubular portion, and wherein the step of assembling said insert assembly comprises pulling said gripping element around said first tubular element until said first gripping portion is aligned with said first circumferential opening and said second gripping portion is aligned with said second circumferential opening, whereby said first gripping portion extends through said first circumferential opening, said second gripping portion extends through said second circumferential opening, and a part of said inner surface of said tubular portion rests upon a part of the outer surface of said first tubular element thereby attach-

ing said gripping element to said first tubular element.

**[0065]** In some embodiments, said first tubular element further comprises a third circumferential opening extending along the through hole axis, and wherein said gripping element further comprises a third gripping portion for frictionally gripping said elongated member of said bracelet and / or necklace, wherein said third gripping portion is protruding from an inner surface of said tubular portion, and wherein the step of assembling said insert assembly comprises pulling said gripping element around said first tubular element until said first gripping portion is aligned with said first circumferential opening, said second gripping portion is aligned with said second circumferential opening, and said third gripping portion is aligned with said third circumferential opening, whereby said first gripping portion extends through said first circumferential opening, said second gripping portion extends through said second circumferential opening, said third gripping portion extends through said third circumferential opening, and a part of said inner surface of said tubular portion rests upon a part of the outer surface of said first tubular element thereby attaching said gripping element to said first tubular element.

**[0066]** In some embodiments, said ornamental component further comprises a locking element having a through hole, wherein said locking element comprises an engagement part for engaging with said insert assembly and a collar for being positioned outside said self-supporting housing, said method further comprising the step of:

- inserting said engagement part of said locking element into said second opening of said self-supporting housing, and
- attaching said engagement part to said insert assembly.

**[0067]** In some embodiments, said engagement part is attached to said insert assembly by a male / female locking mechanism.

**[0068]** According to a fourth aspect, the invention relates to a tubular element for securing a gripping element, for gripping an elongated member of a bracelet and / necklace, in a through hole of an ornamental component, said tubular element having a through hole defining a tubular element through hole axis, wherein said tubular element comprises a first circumferential opening extending along the tubular element through hole axis for receiving a first gripping portion of said gripping element allowing said first gripping portion to extend through said first circumferential opening.

**[0069]** In some embodiments, said tubular element further comprises a second circumferential opening extending along the tubular element through hole axis for receiving a second gripping portion of said gripping element allowing said second gripping portion to extend through said second circumferential opening.

**[0070]** In some embodiments, said tubular element fur-

ther comprises a third circumferential opening extending along the tubular element through hole axis for receiving a third gripping portion of said gripping element allowing said third gripping portion to extend through said third circumferential opening.

**[0071]** In some embodiments, the first circumferential opening, the second circumferential opening and / or the third circumferential opening have a width along the tubular element through hole axis of less than 95%, 90%, 80%, 70%, 60% or 50% of the width of the tubular element along the tubular element through hole axis.

**[0072]** In some embodiments, each of the first circumferential opening, the second circumferential opening and / or the third circumferential opening extends between 5% and 33% of the circumference of the tubular element in a plane being perpendicular to the tubular element through hole axis.

**[0073]** In some embodiments, said tubular element is insertable in a through hole of a self-supporting housing of said ornamental component through a first opening of said through hole of said self-supporting housing.

**[0074]** In some embodiments, the tubular element comprises a first portion and a second portion, wherein the first portion is positioned next to the second portion, the second portion has a lower widest width than the widest width of the first portion measured in a plane being perpendicular to the tubular element through hole axis, and wherein the first circumferential opening is positioned at the second portion of the tubular element.

**[0075]** In some embodiments, the second circumferential opening is positioned at the second portion of the tubular element.

**[0076]** In some embodiments, the third circumferential opening is positioned at the second portion of the tubular element.

**[0077]** In some embodiments, the tubular element further comprises a third portion positioned next to the second portion, and wherein the second portion has a lower widest width than the widest width of the first portion and the third portion, measured in a plane being perpendicular to the tubular element through hole axis.

**[0078]** In some embodiments, the first circumferential opening extends approximately the entire length, along the tubular element through hole axis, of the second portion of the tubular element.

**[0079]** In some embodiments, the second circumferential opening extends approximately the entire length, along the tubular element through hole axis, of the second portion of the tubular element.

**[0080]** In some embodiments, the third circumferential opening extends approximately the entire length, along the tubular element through hole axis, of the second portion of the tubular element.

**[0081]** In some embodiments, said tubular element further comprises a collar for being positioned outside said self-supporting housing said collar comprising a surface for abutting an outer surface of said self-supporting housing for preventing said tubular element from moving in a

first direction along said tubular element through hole axis relative to said self-supporting housing.

**[0082]** The collar may be an integral portion of the first tubular element or may be attached to the first tubular element. The collar may be arranged at a first opening of the through hole of the tubular element.

**[0083]** In some embodiments, said engagement portion is attached to said first tubular element by a male / female locking mechanism, wherein the male part comprises a protruding portion and the female part comprises a recess and / or opening.

**[0084]** The engagement portion may be the male part and the first tubular element may be the female part, i.e. the engagement portion may comprise a protruding portion configured to engage with recess and / or opening in the first tubular element. Alternatively, the first tubular element may be the male part and the engagement portion may be the female part.

**[0085]** In some embodiments, the male / female locking mechanism is of the snap lock type wherein a translation and / or rotation from a free rotational orientation and / or position of the male and female part to a locked rotational orientation and / or position of the male and female part requires less force than a translation and / or rotation from a locked rotational orientation and / or position of the male and female part to a free rotational orientation and / or position of the male and female part.

**[0086]** This may be beneficial as the locking element and the first tubular element typically are permanently attached.

**[0087]** In some embodiments, the male / female locking mechanism may be of the rotational lock type, wherein the female part (locking element or the tubular element) comprises a recess and / or opening configured to allow the protruding portion of the male part to translate inside the recess and / or opening along the tubular element through hole axis when the locking element is in a free rotational orientation relative to the first tubular element, and to be prevented from moving in at least a first direction along the tubular element through hole axis when the locking element is in a locked position relative to the first tubular element and the locking element is in a locked rotational orientation relative to the first tubular element.

**[0088]** In some embodiments, the male part comprises a plurality of protruding portions and the female part comprises a plurality of recesses and / or openings.

**[0089]** The protruding portion of the male part and / or the recess and / or opening of the female part may be configured so that a rotation from the free rotational orientation to the locked rotational orientation requires less force than a rotation from the locked rotational orientation to the free rotational orientation.

**[0090]** In some embodiments, the tubular element has a length along the tubular element through hole axis between 2 mm and 3 cm.

**[0091]** According to a fifth aspect, the invention relates to an ornamental component for a bracelet and / or a necklace said ornamental component having a through

hole allowing said ornamental component to be strung on an elongated member of a bracelet and / or necklace, said through hole defining a through hole axis; said ornamental component comprising:

- a self-supporting housing having a through hole comprising a first opening at a first side of the housing and a second opening at a second side of the housing; and
- a first tubular element having a through hole inserted in said through hole of said self-supporting housing through said first opening of said self-supporting housing; and

wherein said ornamental component further comprises a locking element having a through hole inserted in said through hole of self-supporting housing through said second opening of said self-supporting housing, and said locking element comprises an engagement portion attached to said first tubular element.

**[0092]** Consequently, by providing an ornamental component with a lining by using two parts inserted from two sides of the ornamental component, the lining (the first tubular element and the locking element) may be attached to the bead without deforming it. This allows more complex insert elements to be used such as pre decorated linings and lining composed of a plurality of elements.

**[0093]** An ornamental component may be any component that can be strung on a bracelet and / or necklace for ornamental purposes such as a bead. An ornamental component according to the fifth aspect of the invention may be an freely movable ornamental component or an ornamental component used to organize freely movable beads on a bracelet or necklace. The self-supporting housing may constitute the outer surface of the ornamental component or may be covered with another layer or element constituting the outer surface of the ornamental component. The self supporting housing may have any shape such as approximately spherical, cylindrical or cubical. The self-supporting housing has a structural strength allowing it to be securely handled during the manufacturing process of the ornamental component. The self-supporting housing may provide the primary structural strength of the ornamental component. The self-supporting housing may be made of metal, glass, wood, plastic or a combination thereof. The through hole of the self-supporting housing may have a constant width or may have a varying width (measured in planes being perpendicular to the through hole axis), e.g. the through hole of the self-supporting housing may be wider in the central part of self-supporting housing than at the first opening and the second opening. The inner surface of the through hole of the self-supporting housing may be spaced apart from the insert assembly by another element or a fluid e.g. air. At least a part of the self-supporting housing may be transparent or semi-transparent.

**[0094]** The engagement portion and the first tubular

element may be permanently attached or non-permanently attached.

**[0095]** The first tubular element may have any outer shape such as round or rectangular. Correspondingly, the through hole of the first tubular element may have any shape such as round or rectangular. The first tubular element may be integrally molded, i.e. made from a single mold. The first tubular element may be made of metal and / or plastic.

**[0096]** The engagement portion of the locking element may be attached to the first tubular element by the use of an adhesive or a mechanical locking mechanism.

**[0097]** In some embodiments, said engagement portion is attached to said first tubular element by a male / female locking mechanism, wherein the male part comprises a protruding portion and the female part comprises a recess and / or opening.

**[0098]** The engagement portion may be the male part and the first tubular element may be the female part, i.e. the engagement portion may comprise a protruding portion configured to engage with recess and / or opening in the first tubular element. Alternatively, the first tubular element may be the male part and the engagement portion may be the female part.

**[0099]** In some embodiments, the ornamental component further comprises a second tubular element, and wherein said first tubular element and said engagement portion of said locking element is positioned inside said second tubular element.

**[0100]** This may make it easier to insert the insert assembly into the self-supporting housing. The second tubular element may additionally hide non-decorative elements of the ornamental component, when the self-supporting housing is transparent or semi-transparent. The second tubular element may additionally protect the attachment between the first tubular element and the engagement portion.

**[0101]** The second tubular element may have a length along the through hole axis being approximately equal to the length of the self-supporting housing. The second tubular element may be fully inserted into the through hole of the self-supporting housing. The engagement portion of the locking element may be fully inserted into the second tubular element.

**[0102]** In some embodiments, the male / female locking mechanism is of the snap lock type wherein a translation and / or rotation from a free rotational orientation and / or position of the male and female part, to a locked rotational orientation and / or position of the male and female part, requires less force than a translation and / or rotation from a locked rotational orientation and / or position of the male and female part to a free rotational orientation and / or position of the male and female part.

**[0103]** This may be beneficial as the locking element and the first tubular element typically are permanently attached.

**[0104]** In some embodiments, the male / female locking mechanism is of the rotational lock type, wherein the

female part (the engagement portion or the first tubular element) comprises a recess and / or opening configured to allow the protruding portion of the male part to translate inside the recess and / or opening along the through hole axis when the locking element is in a free rotational orientation relative to the first tubular element, and to be prevented from moving in at least a first direction along the through hole axis when the locking element is in a locked position relative to the first tubular element and the locking element is in a locked rotational orientation relative to the first tubular element.

**[0105]** In some embodiments, the male part comprises a plurality of protruding portions and the female part comprises a plurality of recesses and / or openings.

**[0106]** When the male / female locking mechanism is of the rotational type the locking element may be attached to the first tubular element by firstly rotationally orienting the locking element in the free rotational orientation relative to the first tubular element, next translating the first tubular element and / or the locking element along the through hole axis until the locking element is in the locked position relative to the first tubular element, and finally rotating the first tubular element and / or the locking element from the free rotational orientation to the locked rotational orientation.

**[0107]** The protruding portion of the male part and / or the recess and / or opening of the female part may be configured so that a rotation from the free rotational orientation to the locked rotational orientation requires less force than a rotation from the locked rotational orientation to the free rotational orientation.

**[0108]** In some embodiments, the male part (the engagement portion or the first tubular element) comprises a flexible member configured to deform from a first shape to a second shape when the male part comes into contact with the female part, and further to snap back into approximately the first shape when the flexible member is aligned with the recess and / or opening of the female part, whereby the flexible member engages with the recess and / or opening and locks the male part to the female part, allowing the locking element to be attached to the first tubular element by a pure translation between the two.

**[0109]** In some embodiments, the male part comprises two flexible members, and the female part comprises two recesses and / or openings.

**[0110]** The two flexible members may be arranged at opposite sides of the male part. Correspondingly, the two recesses and / or openings may be arranged at opposite sides of the female part.

**[0111]** In some embodiments, said engagement part of said locking element is inserted into said first tubular element whereby said through hole of said locking element and said through hole of said first tubular element together forms the through hole of said ornamental component.

**[0112]** In some embodiments, said first tubular element at a first end further comprises a collar, wherein

said collar is positioned outside said self-supporting housing at the first opening of said self-supporting housing and comprises a surface abutting an outer surface of said self-supporting housing thereby preventing said first tubular element from moving in a first direction along said through hole axis relative to said ornamental component.

**[0113]** In some embodiments, said locking element further comprises a collar positioned outside said self-supporting housing at the second opening of said self-supporting housing, said collar comprising a surface abutting an outer surface of said self-supporting housing thereby preventing said first tubular element from moving in a second direction along said through hole axis relative to said ornamental component.

**[0114]** In some embodiments, the first tubular element is part of an insert assembly inserted in said through hole of said self-supporting housing through said first opening of said self-supporting housing, wherein said insert assembly is assembled from said first tubular element and a gripping element for frictionally gripping a part of said bracelet and / or necklace; wherein said first tubular element is configured to secure said gripping element inside said through hole of said ornamental component.

**[0115]** According to a sixth aspect, the invention relates to a method for manufacturing an ornamental component, said ornamental component having a through hole allowing said ornamental component to be strung on an elongated member of a bracelet and / or necklace, said through hole defining a through hole axis, the method comprising the steps of:

- providing a self-supporting housing, having an through hole, wherein said through hole comprises a first opening at a first side of the self-supporting housing and a second opening at a second side of the self-supporting housing;
- inserting through said first opening of said self-supporting housing a first tubular element having a through hole;
- inserting through said second opening of said self-supporting housing a locking element having a through hole, said locking element comprising an engagement portion for being positioned inside said through hole of said self-supporting housing; and
- attaching said engagement portion of said locking element to said first tubular element.

**[0116]** Consequently, by using two parts inserted from two sides of the ornamental component, the lining (the first tubular element and the locking element) may be attached to the bead without deforming it. This allows more complex insert elements to be used such as pre decorated linings and linings composed of a plurality of elements.

**[0117]** In some embodiments, the engagement portion is attached to said tubular element by a male / female locking mechanism.

**[0118]** In some embodiments, the method further com-

prises the step of inserting a second tubular element into the through hole of the self-supporting housing, either through said first opening or said second opening of said self-supporting housing, wherein said first tubular element and said engagement portion of said locking element is inserted into said second tubular element.

**[0119]** In some embodiments, the ornamental component is an ornamental component as disclosed in relation to the fifth aspect of the invention.

**[0120]** The different aspects of the present invention can be implemented in different ways including as ornamental components, bracelets or necklaces comprising ornamental components, tubular elements for ornamental components, and methods for manufacturing ornamental components described above and In the following, each yielding one or more of the benefits and advantages described in connection with at least one of the aspects described above, and each having one or more preferred embodiments corresponding to the preferred embodiments described in connection with at least one of the aspects described above and / or disclosed in the dependant claims.

**[0121]** Furthermore, it will be appreciated that embodiments described in connection with one of the aspects described herein may equally be applied to the other aspects. Aspects of the first tubular element disclosed in relation to the first aspect of the invention may be applied to the tubular element disclosed in relation to the fourth aspect of the invention and vice versa. Similarly, aspects disclosed in relation to the ornamental component disclosed in relation to the first aspect of the invention may be applied to the method disclosed in relation to the third aspect of the invention and vice versa. Further aspects disclosed in relation to the ornamental component disclosed in relation to the fifth aspect of the invention may be applied to the method disclosed in relation to the sixth aspect of the invention and vice versa.

#### **Brief description of the drawings**

**[0122]** The above and / or additional objects, features and advantages of the present invention will be further elucidated by the following illustrative and non-limiting detailed description of embodiments of the present invention, with reference to the appended drawings, wherein:

Figs. 1a-c show an ornamental component according to an embodiment of the present invention.

Fig. 2 shows an ornamental component according to an embodiment of the present invention.

Fig. 3 shows an ornamental component according to an embodiment of the present invention.

Figs. 4a-d show a first tubular element according to an embodiment of the present invention.

Fig. 5a-b show a gripping element according to an embodiment of the present invention.

Fig. 6a-b show a self-supporting housing according

to an embodiment of the present invention.

Fig. 7a-b show a second tubular element according to an embodiment of the present invention.

Fig. 8a-c show a locking element according to an embodiment of the present invention.

Fig. 9 shows an ornamental component according to an embodiment of the present invention.

Figs. 10a-d show a first tubular element according to an embodiment of the present invention.

Fig. 11 a-c show a locking element according to an embodiment of the present invention.

Fig. 12 shows an ornamental component according to an embodiment of the present invention.

Figs. 13a-d show a first tubular element according to an embodiment of the present invention.

Fig. 14a-c show a locking element according to an embodiment of the present invention.

Fig. 15 shows an ornamental component according to an embodiment of the present invention.

### Detailed description

**[0123]** In the following description, reference is made to the accompanying figures, which show by way of illustration how the invention may be practiced.

**[0124]** Figs. 1 a-c show an ornamental component 100 for a bracelet and / or a necklace having a through hole defining a through hole axis 104, according to an embodiment of the present invention. Fig. 1a shows a side view, Fig. 1 b shows a front view, and Fig. 1 c shows a cross-section along the line A shown in Fig. 1 b. The ornamental component 100 comprises a self-supporting housing 101 having a through hole 150 comprising a first opening at a first side of the self-supporting housing 151 and a second opening at a second side of the self-supporting housing 152, and an insert assembly 102 103 inserted in said through hole 150 of said self-supporting housing 101. The insert assembly 102 103 comprises a first tubular element 102 and a gripping element 103 (only schematically shown). The gripping element 103 is configured for frictionally gripping a part of a bracelet and / or necklace. The first tubular element 102 has a through hole 140 which in this embodiment forms the full through hole of the ornamental component 100. However, in other embodiments of the invention the through hole of the first tubular element 140 forms only a limited part of the through hole of the ornamental component 100. The through hole of the ornamental component allows it to be strung on an elongated member of a bracelet and / or necklace. The through hole of the self-supporting housing 150 has a varying width (measured in planes being perpendicular to the through hole axis), i.e. the through hole of the self-supporting housing 150 is wider in the central part of self-supporting housing than at the first opening 151 and the second opening 152. The inner surface of the through hole of the self-supporting housing 150 is spaced apart from the insert assembly 102 103 by a fluid e.g. air. The first tubular element 102 is configured to

secure said gripping element 103 inside the through hole 150 of said ornamental component. This may be achieved by attaching said gripping element 103 to the first tubular element 102 e.g. by adhering the two elements together or by positioning the gripping element 103 in a recess of the first tubular element 102 e.g. as shown in Fig. 2. The first tubular element 102 may alternatively secure the gripping element 103 inside the through hole 150 of said ornamental component by having a part of the gripping element wrapped around its outer surface as disclosed in relation to Figs. 3-5.

**[0125]** Fig. 2 shows a cross-section of an ornamental component 200 for a bracelet and / or a necklace having a through hole defining a through hole axis 204 according to an embodiment of the present invention. The ornamental component 200 comprises a self-supporting housing 201 having a through hole 250 comprising a first opening at a first side of the self-supporting housing 251 and a second opening at a second side of the self-supporting housing 252, and an insert assembly 202 203 inserted in said through hole 250 of said self-supporting housing 201. The insert assembly 202 203 comprises a first tubular element 202 and a gripping element 203. The gripping element 203 is configured for frictionally gripping a part of a bracelet and / or necklace. The gripping element 203 has a tubular shape. The first tubular element 202 is configured to secure said gripping element 203 in said through hole of said ornamental component by having recess 290 in the central part of the inner wall of its through hole 240, where the gripping element 203 is positioned. Optionally, the gripping element 203 may further be adhered to the inner wall of the first tubular element 202. The through hole of the first tubular element 240 forms the full through hole of the ornamental component 200.

**[0126]** Fig. 3 shows an exploded view of an ornamental component 300 according to an embodiment of the present invention. The ornamental component 300 comprises an insert assembly 370, a second tubular element 305, a self-supporting housing 301, and a locking element 306. The insert assembly 370 comprises a first tubular element 302 and a gripping element 303. Shown is also the through hole axis 304. The first tubular element 302 has a through hole and comprises a collar 324, a first portion 321, a second portion 322, and a third portion 323, as will be more detailed explained in relation to Figs. 4a-d. The locking element 306 has a through hole, and comprises an engagement part 361 for engaging with the insert assembly 370 and a collar 362 for being positioned outside the self-supporting housing 301. The ornamental component 300 may be manufactured / assembled by firstly assembling the insert assembly 370. The insert assembly 370 may be assembled by arranging the gripping element 303 around the second portion 322 of the first tubular element 302, so that gripping portions of the gripping element 303 (not shown) extends through circumferential openings of the first tubular element 302. Next, the insert assembly 370 may be inserted into the

second tubular element 305. Then the insert assembly 370 with the second tubular element may be inserted into a through hole of the self-supporting housing 350 in a manner so that the collar 324 is positioned outside the self-supporting housing 301. The second tubular element 305 may alternatively be inserted into the through hole of the self-supporting housing 350 before the insert assembly 370 is inserted. The insert assembly 370 and / or the second tubular element 305 may be inserted into the through hole of the self-supporting housing 350 through a first opening 351. The insert assembly 370 and / or the second tubular element 305 may alternatively be inserted into the through hole of the self-supporting housing 350 before the self-supporting housing 301 is fully formed / assembled e.g. the insert assembly 370 and / or the second tubular element may be inserted into a first half of the self-supporting housing 301, whereafter a second half of the self-supporting housing 301 is attached to the first half, thereby forming the finished self-supporting housing 301 with the insert assembly 370 inserted in its through hole 350. Finally, the locking element 306 is inserted in a second opening 352 of the through hole of the self-supporting housing 350, and the engagement part 361 is attached to the first tubular element 302.

**[0127]** Figs. 4a-d show a first tubular element comprising a through hole according to an embodiment of the present invention. The first tubular element shown in Fig. 4-d may correspond to the first tubular element 302 shown in Fig. 3. Fig. 4a shows a side view, Fig. 4b shows a cross-section along the line A, Fig. 4c shows a front view, and Fig. 4d shows a back view. The first tubular element 402 comprises a through hole 474 defining a tubular element through hole axis 404. When the first tubular element 402 is positioned in an ornamental component according to the invention, the tubular element through hole axis 404 and the ornamental component through hole axis will be coincident. The first tubular element 402 comprises a first portion 421, a second portion 422, and a third portion 423. The width of the second portion 422 is lower than the widest width of the first portion 421 and the third portion 423. The first tubular element 402 further comprises a collar 424, a first circumferential opening 426, a second circumferential opening 427, and a third circumferential opening 428. Each of the circumferential openings 426 427 428 extends along the tubular element through hole axis 404. The circumferential openings 426 427 428 are spaced apart by walls 471 472 473 extending along to tubular element through hole axis 404. Each of the circumferential openings 426 427 428 extends B percentage of the circumference of the first tubular element. In the embodiment shown B is equal to 20.8%, i.e. 75 degrees. Correspondingly, each of the walls 471 472 473 extends C percentage of the circumference of the first tubular element. In the embodiment shown C is equal to 12.5%. The circumferential openings 426 427 428 are used to allow gripping parts of the gripping element to extend through, into the through hole 474 of the first tubular element 402, thereby allowing the grip-

ping parts to grip an elongated member of a bracelet and / or necklace. The collar 424 comprises a surface 474 for abutting an outer surface of a self-supporting housing for preventing the first tubular element 402 from moving in a first direction along the through hole axis relative to the self-supporting housing. The width of the through hole 474 is slightly extended in a part of the third portion 423, as illustrated by the broken line in Fig. 4a. This may allow an engagement portion of a locking element to be received, whereby a through hole of the locking element and the through hole 474 of the first tubular element 402 together can form a through hole of an ornamental component. The first tubular element 402 may optionally further comprise mechanical locking means 425 for mechanically attaching the first tubular element 402 with an engagement portion of a locking element e.g. a male / female locking mechanism. In some embodiments, the first tubular element 402 has a length along the tubular element through hole axis 404 between 1 mm and 3 cm.

**[0128]** Figs. 5a-b show a gripping element according to an embodiment of the present invention. Fig. 5a shows a side view, and Fig. 5b shows a front view. The gripping element 503 shown in Fig 5a-b may correspond to the gripping element 303 shown in Fig. 3. The gripping element comprises a tubular portion 531 having an outer surface 532 and an inner surface 536. The gripping element 503 further comprises a first gripping portion 533, a second gripping portion 534, and a third gripping portion 535 protruding from the inner surface 536 of the tubular portion 531. Each of the gripping portions 533 534 535 protrudes from A percentage of the inner surface 536 of the tubular portion 531. In the embodiment shown A is equal to 19.4%, i.e. 70 degrees. The gripping portions 533 534 535 are used to resiliently grip an elongated member of a bracelet and / or necklace. The gripping element 503 may be made of a flexible material e.g. a silicone like material. The gripping element 503 may be attached with a first tubular element 402 as shown in Fig. 4a-d by pulling the gripping element 503 around the first tubular element 402 until the first gripping portion 533 is aligned with the first circumferential opening 426, the second gripping portion 534 is aligned with the second circumferential opening 427, and the third gripping portion 535 is aligned with the third circumferential opening 428, whereby the first gripping portion 533 extends through the first circumferential opening 426, the second gripping portion 534 extends through the second circumferential opening 427, the third gripping portion 535 extends through the third circumferential opening 428, and a part of the inner surface 536 of the tubular portion 531 rests upon a part of the outer surface 471 472 473 of the first tubular element 402 thereby attaching the gripping element 503 to the first tubular element 502. The gripping element 503 may have a length C along the through hole axis, being approximately equal to the length of the circumferential openings of a first tubular element.

**[0129]** Figs. 6a-b show a self-supporting housing according to an embodiment of the present invention. Fig.

6a shows a side view and Fig. 6b shows a front view. The self-supporting housing 601 shown in Figs. 6a-b may correspond to the self-supporting housing 301 shown in Fig. 3. The self-supporting housing 601 has a through hole 650 comprising a first opening at a first side of the self-supporting housing 651 and a second opening at a second side of the self-supporting housing 652. The trough hole of the self-supporting housing 650 has a varying width (measured in planes being perpendicular to the through hole axis), i.e. the through hole of the self-supporting housing 650 is wider in the central part of self-supporting housing than at the first opening 651 and the second opening 652. The self-supporting housing 601 comprises a planar surface 653 at the first opening 651 for abutting a surface of a collar of a first tubular element. Correspondingly, the self supporting housing 601 comprises a planar surface 654 for abutting a surface of a collar of a locking element.

**[0130]** Figs. 7a-b show a second tubular element according to an embodiment of the present invention. Fig. 7a shows a side view and Fig. 7b shows a front view. The second tubular element 705 shown in Figs. 7a-b may correspond to the second tubular element 305 shown in Fig. 3. The second tubular element comprises a through hole 755, wherein a first tubular element with a gripping element attached may be positioned.

**[0131]** Figs. 8a-b show a locking element according to an embodiment of the present invention. Fig. 8a shows a top view, Fig. 8b shows a back view and Fig. 8c shows a front view. The locking element 606 shown in Figs 8a-c may correspond to the locking element 306 shown in Fig. 3. The locking element 806 comprises an engagement portion 861 for being attached with a part of a first tubular element, a collar for being positioned outside a self-supporting housing, and a through hole 865. The engagement portion 861 may optionally comprise mechanical locking means 864 for mechanically attaching the engagement portion 861 with a first tubular element 402 e.g. a male / female locking mechanism. The collar 862 comprises a planar surface 863 for abutting with a surface of a self-supporting housing.

**[0132]** Fig. 9 shows an exploded perspective view of an ornamental component with possible dimensions according to an embodiment of the present invention. The ornamental component 900 comprises a first tubular element 902, a gripping element 903, a self-supporting housing 901, a second tubular element 905, and a locking element 906.

**[0133]** Fig. 10a-d show a first tubular element according to an embodiment of the present invention. Fig. 10a shows a top view, Fig. 10b shows a side view, Fig. 10c shows a front view and Fig. 10d shows a back view. The first tubular element 1002 has a through hole 1074 and comprises a collar 1024, a first portion 1021, a second portion 1022, and a third portion 1023. The collar 1024, the first portion 1021, and the second portion 1022 may be identical to the corresponding parts of the first tubular element shown in Fig. 4a-d. The third portion 1023 com-

prises mechanical locking means in the form of a female part of male / female locking mechanism 1075 1076. The female part 1075 1076 comprises a first opening 1075 and a second opening 1076 extending along the through hole axis. The first opening 1075 and the second opening 1076 are positioned opposite to each other.

**[0134]** Fig. 11a-d show a locking element 1106 according to an embodiment of the present invention. Fig. 11a shows a top view, Fig. 11b shows a front view and Fig. 11c shows a back view. The locking element 1106 has a through hole 1165 and comprises a collar 1162 and an engagement portion 1161. The collar 1162 may be identical to the collar of the locking element shown in Fig. 8. The engagement portion 1161 comprises mechanical locking means in the form of the male part 1166 1167 of a male / female locking mechanism. The male part 1166 1167 comprises a first flexible member 1166 and a second flexible member 1167. The first and second flexible member 1166 1167 each comprises a protruding portion 1168 1169. The male / female locking mechanisms shown in Figs. 10a-c and Figs. 11 a-c are configured to function together, thus the protruding portions 1168 1169 are configured to fit the openings 1075 1076. The locking element 1106 may be attached to the first tubular element 1002 by moving the two elements together until the male part comes into contact with the female part, whereby the first and second flexible member 1166 1167 are deformed from a first shape to a second shape, i.e. the first and second flexible member 1166 1167 are both progressively bent inwards. This is a result of an interaction between the rounded front surface of the two flexible members 1166 1167 and the rim 1077 of the through hole 1074 of the first tubular element 1002. When the two flexible members 1166 1667 are aligned with the two openings 1075 1076 of the first tubular element 1002, the two flexible members 1166 1667 snap back into approximately the first shape, whereby the protruding portions of the two flexible members 1168 1669 engages with the openings 1075 1076 and locks the locking element 1106 to the first tubular element 1002. Thus, the locking element 1106 can be attached to the first tubular element 1002 by a pure translation between the two. The male / female locking mechanism 1075 1076 1166 1167 is of the snap lock type wherein a translation from a free position of the male and female part, to a locked position of the male and female part, requires less force than a translation from a locked position of the male and female part to a free position of the male and female part. This is a result of the special shape of the protruding potions 1168 1669 and the openings 1075 1076. This may be beneficial as the locking element 1106 and the first tubular element 1002 typically are permanently attached.

**[0135]** Fig. 12 shows a central cross-section of a fully assembled ornamental component comprising a first tubular element and a locking element as disclosed in relation to Figs. 10a-d and Figs. 11a-c according to an embodiment of the present invention. The ornamental component 1200 comprises a self-supporting housing 1201,

a first tubular element 1202, a gripping element 1203, a locking element 1206 and a second tubular element 1205. The ornamental component 1200 has a through hole 1250 defining a through hole axis 1204. The gripping element 1203 may be identical to the gripping element shown in Figs. 5a-b, the self-supporting housing 1201 may be identical to the self-supporting housing shown in Figs. 6a-b, and the second tubular element 1205 may be identical to the second tubular element shown in Figs. 7a-b. It can be seen how gripping portions of the gripping element 1203 protrudes into the through hole 1250 of the ornamental component 1200 allowing the gripping portions to frictionally grip an elongated member of a bracelet and / or necklace e.g. a chain of a bracelet and / or necklace.

**[0136]** Fig. 13a-d show a first tubular element according to an embodiment of the present invention. Fig. 13a shows a top view, Fig. 13b shows a side view, Fig. 13c shows a front view, and Fig. 13d shows a back view. The first tubular element 1302 has a through hole 1374 and comprises a collar 1324, a first portion 1321, a second portion 1322, and a third portion 1323. The collar 1324, the first portion 1321, and the second portion 1322 may be identical to the corresponding parts of the first tubular element shown in Fig. 4a-d. The third portion 1323 comprises mechanical locking means in the form of a female part of male / female locking mechanism 1375 1376. The female part 1075 1076 comprises a first opening / or recess 1375 and a second opening or recess 1376. The first opening 1375 and the second opening 1376 are positioned opposite to each other.

**[0137]** Fig. 14a-d show a locking element 1406 according to an embodiment of the present invention. Fig. 14a shows a top view, Fig. 14b shows a front view, and Fig. 14c shows a back view. The locking element 1406 has a through hole 1465, and comprises a collar 1462 and an engagement portion 1461. The collar 1462 may be identical to the collar of the locking element shown in Fig. 8. The engagement portion 1461 comprises mechanical locking means in the form of the male part 1468 1469 of a male / female locking mechanism. The male part 1468 1469 comprises a first protruding portion 1468 and a second protruding portion 1169. The male / female locking mechanisms shown in Fig. 13a-c and Fig. 114-c are configured to function together, thus the protruding portions 1468 1469 are configured to fit the openings 1375 1376. The male / female locking mechanism is of the rotational type. The locking element 1406 may be attached to the first tubular element 1302 by firstly rotationally orienting the locking element 1406 in a free rotational orientation relative to the first tubular element 1302 (with the protruding portions 1468 1469 aligned with the openings 1375 1376), next translating the locking element 1406 along the through hole axis, and finally rotating the locking element 1406 from the free rotational orientation to a locked rotational orientation.

**[0138]** Fig. 15 shows a central cross-section of a fully assembled ornamental component comprising a first tu-

bular element and a locking element as disclosed in relation to Fig 13a-d and Fig. 14a-c, according to an embodiment of the present invention. The ornamental component 1500 comprises a self-supporting housing 1501, a first tubular element 1502, a gripping element 1503, a locking element 1506, and a second tubular element 1505. The ornamental component 1500 has a through hole 1550 defining a through hole axis 504. The gripping element 1503 may be identical to the gripping element shown in Fig. 5a-b, the self-supporting housing 1501 may be identical to the self-supporting housing shown in Fig. 6a-b, and the second tubular element 1505 may be identical to the second tubular element shown in Fig. 7a-b.

**[0139]** Although some embodiments have been described and shown in detail, the invention is not restricted to them, but may also be embodied in other ways within the scope of the subject matter defined in the following claims. In particular, it is to be understood that other embodiments may be utilised and structural and functional modifications may be made without departing from the scope of the present invention as defined by the appended claims.

**[0140]** In device claims enumerating several means, several of these means can be embodied by one and the same item of hardware. The mere fact that certain measures are recited in mutually different dependent claims or described in different embodiments does not indicate that a combination of these measures cannot be used to advantage.

**[0141]** It should be emphasized that the term "comprises/comprising" when used in this specification is taken to specify the presence of stated features, integers, steps or components but does not preclude the presence or addition of one or more other features, integers, steps, components or groups thereof.

## Claims

1. An ornamental component (100) for a bracelet and / or a necklace, said ornamental component (100) having a through hole (140) allowing said ornamental component (100) to be strung on an elongated member of a bracelet and / or necklace, said through hole defining a through hole axis (104); said ornamental component comprising:
  - a self-supporting housing (101) having a through hole (150) comprising a first opening at a first side of the self-supporting housing (151) and a second opening at a second side of the self-supporting housing (152); and
  - an insert assembly (102, 103) inserted in said through hole of said self-supporting housing;

wherein said insert assembly (102, 103) is assembled from a first tubular element (102) having a through hole (140) that forms at least a part of said

- through hole of said ornamental component and a gripping element (103) for frictionally gripping a part of said bracelet and / or necklace; wherein said first tubular element (102) is configured to secure said gripping element (103) inside said through hole of said ornamental component (100), said first tubular element (102) comprises a first circumferential opening (426) extending along the through hole axis (104), and wherein said gripping element (103) comprises a first gripping portion (533) for frictionally gripping said elongated member of said bracelet and / or necklace, wherein said first gripping portion (533) extends through said first circumferential opening.
2. An ornamental component according to claim 1, wherein the insert assembly is inserted into the through hole of the self-supporting housing through the first opening of the self-supporting housing.
  3. An ornamental component according to claim 1 or 2, wherein said gripping element comprises a tubular portion, said first gripping portion protrudes from an interior surface of said tubular portion, and wherein said tubular portion of said gripping element surrounds a part of said first tubular element.
  4. An ornamental component according to claim 3, wherein said first tubular element comprises a second circumferential opening extending along the through hole axis and said gripping element comprises a second gripping portion protruding from an interior surface of said tubular portion of said gripping element, wherein said second gripping portion extends through said second circumferential opening.
  5. An ornamental component according to claim 4, wherein said first tubular element comprises a third circumferential opening extending along the through hole axis and said gripping element comprises a third gripping portion protruding from an interior surface of said tubular portion of said gripping element, and wherein said third gripping portion extends through said third circumferential opening.
  6. An ornamental component according to any one of claims 3 to 5, wherein the first tubular element comprises a first portion and a second portion, wherein the second portion has a lower widest width than the widest width of the first portion, and wherein the tubular portion of the gripping element is arranged to fit snugly around the second portion of the first tubular element, and abutting the first portion of the first tubular element whereby the gripping element is prevented from moving in a first direction along the through hole axis relative to the first tubular element.
  7. An ornamental component according to claim 6, wherein the first tubular element further comprises a third portion, and wherein the second portion has a lower widest width than the widest width of the first portion and the third portion, and wherein the tubular portion of the gripping element further abuts the third portion of the first tubular element thereby preventing the gripping element from moving in any direction along the through hole axis relative to the first tubular element.
  8. An ornamental component according to any one of claims 1 to 7, wherein the ornamental component further comprises a second tubular element, and wherein said first tubular element is positioned inside said second tubular element.
  9. An ornamental component according to any one of claims 1 to 8, wherein said first tubular element of said insert assembly at a first end further comprises a collar, wherein said collar is positioned outside said self-supporting housing at the first opening of said self-supporting housing and comprises a surface abutting an outer surface of said self-supporting housing thereby preventing said first tubular element of said insert assembly from moving in a first direction along said through hole axis relative to said ornamental component.
  10. An ornamental component according to any one of claims 1 to 9, wherein said ornamental component further comprises a locking element having a through hole wherein said locking element comprises an engagement portion positioned inside said self-supporting housing and a collar positioned outside said self-supporting housing at the second opening of said self-supporting housing, wherein said engagement portion is attached to said first tubular element and said collar comprises a surface abutting an outer surface of said self-supporting housing thereby preventing said first tubular element of said insert assembly from moving in a second direction along said through hole axis relative to said ornamental component.
  11. An ornamental component according to claim 10, wherein said engagement portion is attached to said first tubular element by a male / female locking mechanism, wherein the male part comprises a protruding portion and the female part comprises a recess and / or opening.
  12. A bracelet or a necklace comprising:
    - an elongated member; and
    - a first ornamental component according to any one of claims 1 to 11, strung on said elongated member;
 wherein the first ornamental component is config-

ured so that the gripping element resiliently grips the elongated member to fix the first ornamental component along the elongated member until a particular force is acting on said first ornamental component, whereby the first ornamental component can be moved along the elongated member.

13. A method for manufacturing an ornamental component, said ornamental component having a through hole allowing said ornamental component to be strung on an elongated member of a bracelet and / or necklace, said through hole defining a through hole axis, comprising the steps of:

- providing a self-supporting housing, having a through hole, wherein said through hole comprises a first opening at a first side of the self-supporting housing and a second opening at a second side of the self-supporting housing;
- assembling an insert assembly comprising a first tubular element having a through hole that at least partly forms said through hole of said ornamental component, and a gripping element for frictionally gripping said elongated member of a bracelet and / or a necklace; and
- inserting said insert assembly in said through hole of said housing

wherein said first tubular element comprises a first circumferential opening extending along the through hole axis, and wherein said gripping element comprises a first gripping portion, for frictionally gripping said elongated member of said bracelet and / or necklace, and a tubular portion, wherein said first gripping portion is protruding from an inner surface of said tubular portion, and wherein the step of assembling said insert assembly comprises pulling said gripping element around said first tubular element until said first gripping portion is aligned with said first circumferential opening, whereby said first gripping portion extends through said first circumferential opening and a part of said inner surface of said tubular portion rests upon a part of the outer surface of said first tubular element thereby securing said gripping element to said first tubular element.

14. A method according to claim 13, wherein the insert assembly is inserted in said through hole of said self-supporting housing through said first opening of said self-supporting housing.

#### Patentansprüche

1. Schmuckkomponente (100) für ein Armband und/oder eine Halskette, wobei die Schmuckkomponente (100) ein Durchgangsloch (140) hat, damit die Schmuckkomponente (100) auf ein längliches Ele-

ment eines Armbands und/oder einer Halskette aufgefädelt werden kann, wobei das Durchgangsloch eine Durchgangslochachse (104) definiert, wobei die Schmuckkomponente Folgendes umfasst:

- ein selbsttragendes Gehäuse (101) mit einem Durchgangsloch (150), das eine erste Öffnung an einer ersten Seite des selbsttragenden Gehäuses (151) und eine zweite Öffnung an einer zweiten Seite des selbsttragenden Gehäuses (152) umfasst, und
- eine in das Durchgangsloch des selbsttragenden Gehäuses eingeführte Einsatzanordnung (102, 103),

wobei die Einsatzanordnung (102, 103) aus einem ersten rohrförmigen Element (102) mit einem Durchgangsloch (140), das mindestens einen Teil des Durchgangslochs der Schmuckkomponente bildet, und einem Greifelement (103) zum reibungsmäßigen Greifen eines Teils des Armbands und/oder der Halskette zusammengebaut ist, wobei das erste rohrförmige Element (102) dazu konfiguriert ist, das Greifelement (103) in dem Durchgangsloch der Schmuckkomponente (100) zu befestigen, das erste rohrförmige Element (102) eine erste Umfangsöffnung (426) umfasst, die sich entlang der Durchgangslochachse (104) erstreckt, und wobei das Greifelement (103) einen ersten Greifabschnitt (533) zum reibungsmäßigen Greifen des länglichen Elements des Armbands und/oder der Halskette umfasst, wobei sich der erste Greifabschnitt (533) durch die erste Umfangsöffnung erstreckt.

2. Schmuckkomponente nach Anspruch 1, wobei die Einsatzanordnung durch die erste Öffnung des selbsttragenden Gehäuses in das Durchgangsloch des selbsttragenden Gehäuses eingeführt wird.

3. Schmuckkomponente nach Anspruch 1 oder 2, wobei das Greifelement einen rohrförmigen Abschnitt umfasst, der erste Greifabschnitt von einer inneren Fläche des rohrförmigen Abschnitts vorragt und wobei der rohrförmige Abschnitt des Greifelements einen Teil des ersten rohrförmigen Elements umgibt.

4. Schmuckkomponente nach Anspruch 3, wobei das erste rohrförmige Element eine zweite Umfangsöffnung umfasst, die sich entlang der Durchgangslochachse erstreckt, und das Greifelement einen zweiten Greifabschnitt umfasst, der von einer inneren Fläche des rohrförmigen Abschnitts des Greifelements vorragt, wobei sich der zweite Greifabschnitt durch die zweite Umfangsöffnung erstreckt.

5. Schmuckkomponente nach Anspruch 4, wobei das erste rohrförmige Element eine dritte Umfangsöffnung umfasst, die sich entlang der Durchgangs-

- lochachse erstreckt, und das Greifelement einen dritten Greifabschnitt umfasst, der von einer inneren Fläche des rohrförmigen Abschnitts des Greifelements vorragt, wobei sich der dritte Greifabschnitt durch die dritte Umfangsöffnung erstreckt.
6. Schmuckkomponente nach einem der Ansprüche 3 bis 5, wobei das erste rohrförmige Element einen ersten Abschnitt und einen zweiten Abschnitt umfasst, wobei die breiteste Breite des zweiten Abschnitts geringer als die breiteste Breite des ersten Abschnitts ist und wobei der rohrförmige Abschnitt des Greifelements so angeordnet ist, dass er passgenau um den zweiten Abschnitt des ersten rohrförmigen Elements passt und an den ersten Abschnitt des ersten rohrförmigen Elements anschlägt, wodurch verhindert wird, dass sich das Greifelement in einer ersten Richtung entlang der Durchgangslochachse bezüglich des ersten rohrförmigen Elements bewegt.
7. Schmuckkomponente nach Anspruch 6, wobei das erste rohrförmige Element ferner einen dritten Abschnitt umfasst und wobei die breiteste Breite des zweiten Abschnitts geringer als die breiteste Breite des ersten Abschnitts und des dritten Abschnitts ist und wobei der rohrförmige Abschnitt des Greifelements ferner an den dritten Abschnitt des ersten rohrförmigen Elements anschlägt, wodurch verhindert wird, dass sich das Greifelement in irgendeiner Richtung entlang der Durchgangslochachse bezüglich des ersten rohrförmigen Elements bewegt.
8. Schmuckkomponente nach einem der Ansprüche 1 bis 7, wobei die Schmuckkomponente ferner ein zweites rohrförmiges Element umfasst und wobei das erste rohrförmige Element im zweiten rohrförmigen Element positioniert ist.
9. Schmuckkomponente nach einem der Ansprüche 1 bis 8, wobei das erste rohrförmige Element der Einsatzanordnung ferner an einem ersten Ende einen Bund umfasst, wobei der Bund außerhalb des selbsttragenden Gehäuses an der ersten Öffnung des selbsttragenden Gehäuses positioniert ist und eine Fläche umfasst, die an eine äußere Fläche des selbsttragenden Gehäuses anschlägt, wodurch verhindert wird, dass sich das erste rohrförmige Element der Einsatzanordnung in einer ersten Richtung entlang der Durchgangslochachse bezüglich der Schmuckkomponente bewegt.
10. Schmuckkomponente nach einem der Ansprüche 1 bis 9, wobei die Schmuckkomponente ferner ein Verriegelungselement mit einem Durchgangsloch umfasst, wobei das Verriegelungselement einen Eingriffsabschnitt, der im selbsttragenden Gehäuse positioniert ist, und einen Bund, der außerhalb des selbsttragenden Gehäuses an der zweiten Öffnung des selbsttragenden Gehäuses positioniert ist, umfasst, wobei der Bund eine Fläche umfasst, die an eine äußere Fläche des selbsttragenden Gehäuses anschlägt, wodurch verhindert wird, dass sich das erste rohrförmige Element der Einsatzanordnung in einer zweiten Richtung entlang der Durchgangslochachse bezüglich der Schmuckkomponente bewegt.
11. Schmuckkomponente nach Anspruch 10, wobei der Eingriffsabschnitt über einen Steck-/Aufnahmeverriegelungsmechanismus am ersten rohrförmigen Element angebracht ist, wobei der Steckteil einen vorragenden Abschnitt umfasst und der Aufnahme- teil eine Aussparung und/oder Öffnung umfasst.
12. Armband oder Halskette, umfassend:
- ein längliches Element und
  - eine erste Schmuckkomponente nach einem der Ansprüche 1 bis 11, die auf das längliche Element aufgefädelt ist,
- wobei die erste Schmuckkomponente so konfiguriert ist, dass das Greifelement das längliche Element federnd ergreift, um die erste Schmuckkomponente entlang dem länglichen Element zu befestigen, bis die erste Schmuckkomponente mit einer bestimmten Kraft beaufschlagt wird, wodurch die erste Schmuckkomponente entlang dem länglichen Element bewegt werden kann.
13. Verfahren zur Herstellung einer Schmuckkomponente, wobei die Schmuckkomponente ein Durchgangsloch hat, das gestattet, dass die Schmuckkomponente auf ein längliches Element eines Armbands und/oder einer Halskette aufgefädelt werden kann, wobei das Durchgangsloch eine Durchgangslochachse definiert, umfassend die folgenden Schritte:
- Bereitstellen eines selbsttragenden Gehäuses mit einem Durchgangsloch, wobei das Durchgangsloch eine erste Öffnung an einer ersten Seite des selbsttragenden Gehäuses und eine zweite Öffnung an einer zweiten Seite des selbsttragenden Gehäuses umfasst,
  - Zusammenbauen einer Einsatzanordnung, die ein erstes rohrförmiges Element mit einem Durchgangsloch, das mindestens teilweise das Durchgangsloch der Schmuckkomponente bildet, und ein Greifelement zum reibungsmäßigen Greifen des länglichen Elements eines Armbands und/oder einer Halskette umfasst, und
  - Einführen der Einsatzanordnung in das Durchgangsloch des Gehäuses,

wobei das erste rohrförmige Element eine erste Umfangsöffnung umfasst, die sich entlang der Durchgangslochachse erstreckt, und wobei das Greifelement einen ersten Greifabschnitt zum reibungsmäßigen Greifen des länglichen Elements des Armbands und/oder der Halskette, und einen rohrförmigen Abschnitt umfasst, wobei der erste Greifabschnitt von einer inneren Fläche des rohrförmigen Abschnitts vorragt und wobei der Schritt des Zusammenbauens der Einsatzanordnung das Ziehen des Greifelements um das erste rohrförmige Element herum, bis der erste Greifabschnitt auf die erste Umfangsöffnung ausgerichtet ist, umfasst, wodurch sich der erste Greifabschnitt durch die erste Umfangsöffnung erstreckt und ein Teil der inneren Fläche des rohrförmigen Abschnitts auf einem Teil der äußeren Fläche des ersten rohrförmigen Elements ruht, wodurch das Greifelement am ersten rohrförmigen Element befestigt wird.

14. Verfahren nach Anspruch 13, wobei die Einsatzanordnung durch die erste Öffnung des selbsttragenden Gehäuses in das Durchgangsloch des selbsttragenden Gehäuses eingeführt wird.

#### Revendications

1. Composant décoratif (100) pour un bracelet et/ou un collier, ledit composant décoratif (100) ayant un trou traversant (140) permettant audit composant décoratif (100) d'être enfilé sur un organe allongé d'un bracelet et/ou d'un collier, ledit trou traversant définissant un axe de trou traversant (104) ; ledit composant décoratif comprenant :

- un boîtier autoportant (101) ayant un trou traversant (150) comprenant une première ouverture au niveau d'un premier côté du boîtier autoportant (151) et une deuxième ouverture au niveau d'un deuxième côté du boîtier autoportant (152) ; et
- un ensemble d'insert (102, 103) inséré dans ledit trou traversant dudit boîtier autoportant ;

dans lequel ledit ensemble d'insert (102, 103) est assemblé à partir d'un premier élément tubulaire (102) ayant un trou traversant (140) qui forme au moins une partie dudit trou traversant dudit composant décoratif et d'un élément de préhension (103) pour saisir par friction une partie dudit bracelet et/ou dudit collier ; ledit premier élément tubulaire (102) étant configuré pour fixer ledit élément de préhension (103) à l'intérieur dudit trou traversant dudit composant décoratif (100), ledit premier élément tubulaire (102) comprenant une première ouverture circonférentielle (426) s'étendant le long de l'axe de trou traversant (104), et ledit élément de préhension

(103) comprenant une première portion de préhension (533) pour saisir par friction ledit organe allongé dudit bracelet et/ou dudit collier, ladite première portion de préhension (533) s'étendant à travers ladite première ouverture circonférentielle.

2. Composant décoratif selon la revendication 1, l'ensemble d'insert étant inséré à l'intérieur du trou traversant du boîtier autoportant à travers la première ouverture du boîtier autoportant.
3. Composant décoratif selon la revendication 1 ou 2, ledit élément de préhension comprenant une portion tubulaire, ladite première portion de préhension faisant saillie à partir d'une surface intérieure de ladite portion tubulaire, et ladite portion tubulaire dudit élément de préhension entourant une partie dudit premier élément tubulaire.
4. Composant décoratif selon la revendication 3, ledit premier élément tubulaire comprenant une deuxième ouverture circonférentielle s'étendant le long de l'axe de trou traversant et ledit élément de préhension comprenant une deuxième portion de préhension faisant saillie à partir d'une surface intérieure de ladite portion tubulaire dudit élément de préhension, ladite deuxième portion de préhension s'étendant à travers ladite deuxième ouverture circonférentielle.
5. Composant décoratif selon la revendication 4, ledit premier élément tubulaire comprenant une troisième ouverture circonférentielle s'étendant le long de l'axe de trou traversant et ledit élément de préhension comprenant une troisième portion de préhension faisant saillie à partir d'une surface intérieure de ladite portion tubulaire dudit élément de préhension, et ladite troisième portion de préhension s'étendant à travers ladite troisième ouverture circonférentielle.
6. Composant décoratif selon l'une quelconque des revendications 3 à 5, le premier élément tubulaire comprenant une première portion et une deuxième portion, la deuxième portion ayant une plus grande largeur inférieure à la plus grande largeur de la première portion, et la portion tubulaire de l'élément de préhension étant agencée pour s'ajuster de manière serrée autour de la deuxième portion du premier élément tubulaire, et en butée contre la première portion du premier élément tubulaire, l'élément de préhension étant ainsi empêché de se déplacer dans un premier sens le long de l'axe de trou traversant par rapport au premier élément tubulaire.
7. Composant décoratif selon la revendication 6, le premier élément tubulaire comprenant en outre une troisième portion, et la deuxième portion ayant une plus grande largeur inférieure à la plus grande largeur de

- la première portion et de la troisième portion, et la portion tubulaire de l'élément de préhension étant en outre en butée contre la troisième portion du premier élément tubulaire, empêchant ainsi l'élément de préhension de se déplacer dans n'importe quel sens le long de l'axe de trou traversant par rapport au premier élément tubulaire .
8. Composant décoratif selon l'une quelconque des revendications 1 à 7, le composant décoratif comprenant en outre un deuxième élément tubulaire, et ledit premier élément tubulaire étant positionné à l'intérieur dudit deuxième élément tubulaire.
9. Composant décoratif selon l'une quelconque des revendications 1 à 8, ledit premier élément tubulaire dudit ensemble d'insert comprenant en outre une collerette à une première extrémité, ladite collerette étant positionnée à l'extérieur dudit boîtier autoportant au niveau de la première ouverture dudit boîtier autoportant et comprenant une surface en butée contre une surface extérieure dudit boîtier autoportant, empêchant ainsi ledit premier élément tubulaire dudit ensemble d'insert de se déplacer dans un premier sens le long dudit axe de trou traversant par rapport audit composant décoratif.
10. Composant décoratif selon l'une quelconque des revendications 1 à 9, ledit composant décoratif comprenant en outre un élément de verrouillage ayant un trou traversant, ledit élément de verrouillage comprenant une portion d'engagement positionnée à l'intérieur dudit boîtier autoportant et une collerette positionnée à l'extérieur dudit boîtier autoportant au niveau de la deuxième ouverture dudit boîtier autoportant, ladite portion d'engagement étant fixée audit premier élément tubulaire et ladite collerette comprenant une surface en butée contre une surface extérieure dudit boîtier autoportant, empêchant ainsi ledit premier élément tubulaire dudit ensemble d'insert de se déplacer dans un deuxième sens le long dudit axe de trou traversant par rapport audit composant décoratif.
11. Composant décoratif selon la revendication 10, ladite portion d'engagement étant fixée audit premier élément tubulaire par un mécanisme de verrouillage mâle/femelle, la partie mâle comprenant une portion saillante et la partie femelle comprenant un évidement et/ou une ouverture.
12. Bracelet ou collier comprenant :
- un organe allongé ; et
  - un premier composant décoratif selon l'une quelconque des revendications 1 à 11, enfilé sur ledit organe allongé ;
- le premier composant décoratif étant configuré de telle sorte que l'élément de préhension saisisse de manière élastique l'organe allongé pour fixer le premier composant décoratif le long de l'organe allongé jusqu'à ce qu'une force particulière agisse sur ledit premier composant décoratif, le premier composant décoratif pouvant ainsi être déplacé le long de l'organe allongé.
13. Procédé de fabrication d'un composant décoratif, ledit composant décoratif ayant un trou traversant permettant audit composant décoratif d'être enfilé sur un organe allongé d'un bracelet et/ou d'un collier, ledit trou traversant définissant un axe de trou traversant, comprenant les étapes de :
- fourniture d'un boîtier autoportant ayant un trou traversant, ledit trou traversant comprenant une première ouverture au niveau d'un premier côté du boîtier autoportant et une deuxième ouverture au niveau d'un deuxième côté du boîtier autoportant ;
  - assemblage d'un ensemble d'insert comprenant un premier élément tubulaire ayant un trou traversant qui forme au moins partiellement ledit trou traversant dudit composant décoratif et un élément de préhension pour saisir par friction ledit organe allongé d'un bracelet et/ou d'un collier ; et
  - insertion dudit ensemble d'insert dans ledit trou traversant dudit boîtier,
- dans lequel ledit premier élément tubulaire comprend une première ouverture circonférentielle s'étendant le long de l'axe de trou traversant, et ledit élément de préhension comprenant une première portion de préhension, pour saisir par friction ledit organe allongé dudit bracelet et/ou dudit collier, et une portion tubulaire, ladite première portion de préhension faisant saillie à partir d'une surface intérieure de ladite portion tubulaire, et l'étape d'assemblage dudit ensemble d'insert comprenant la traction dudit élément de préhension autour dudit premier élément tubulaire jusqu'à ce que ladite première portion de préhension soit alignée avec ladite première ouverture circonférentielle, ladite première portion de préhension s'étendant ainsi à travers ladite première ouverture circonférentielle et une partie de ladite surface intérieure de ladite portion tubulaire reposant sur une partie de la surface extérieure dudit premier élément tubulaire, fixant ainsi ledit élément de préhension audit premier élément tubulaire.
14. Procédé selon la revendication 13, l'ensemble d'insert étant inséré dans ledit trou traversant dudit boîtier autoportant à travers ladite première ouverture dudit boîtier autoportant.

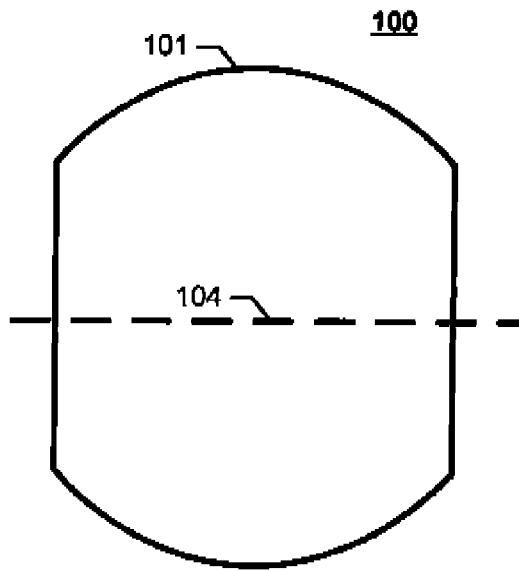


Fig. 1a

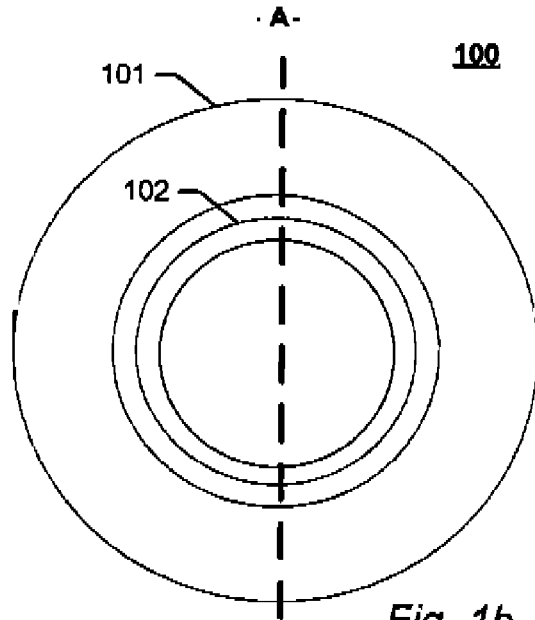


Fig. 1b

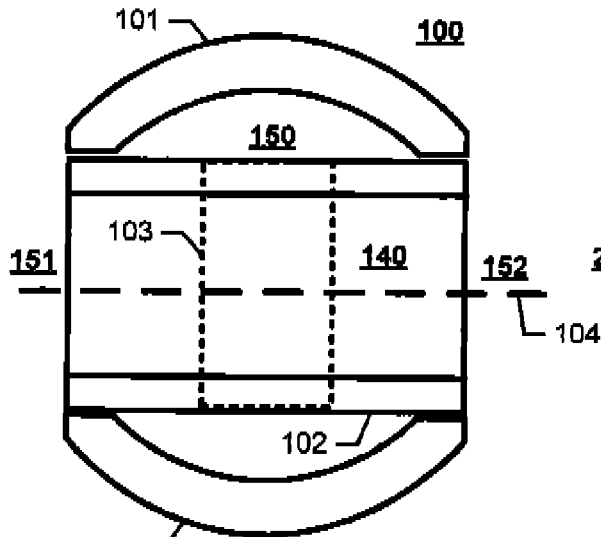


Fig. 1c

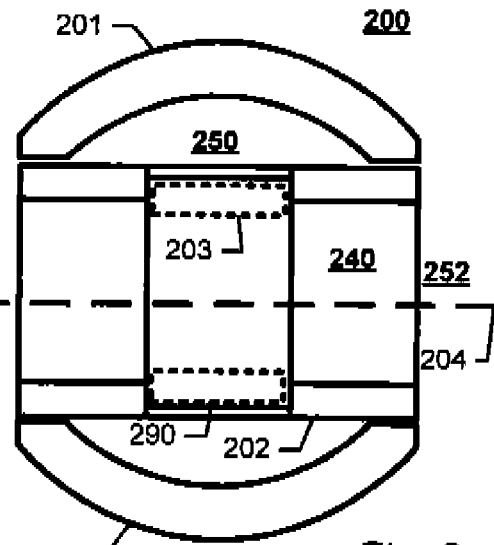


Fig. 2

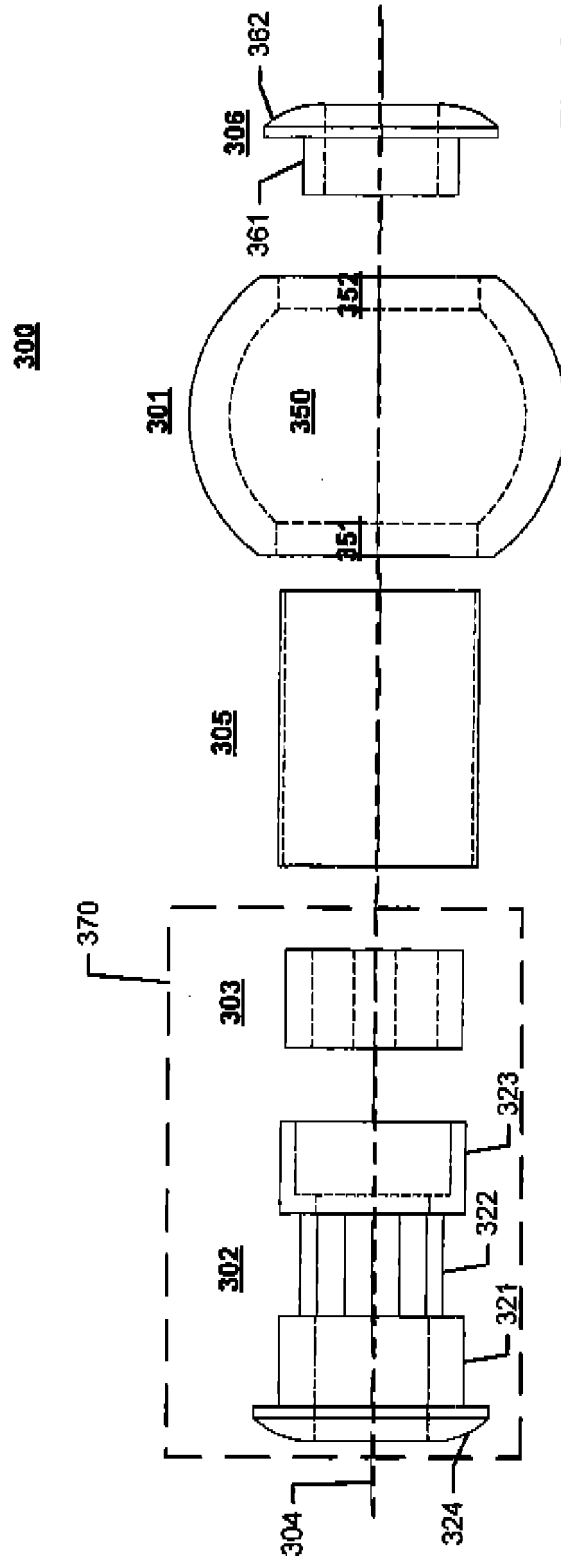


Fig. 3

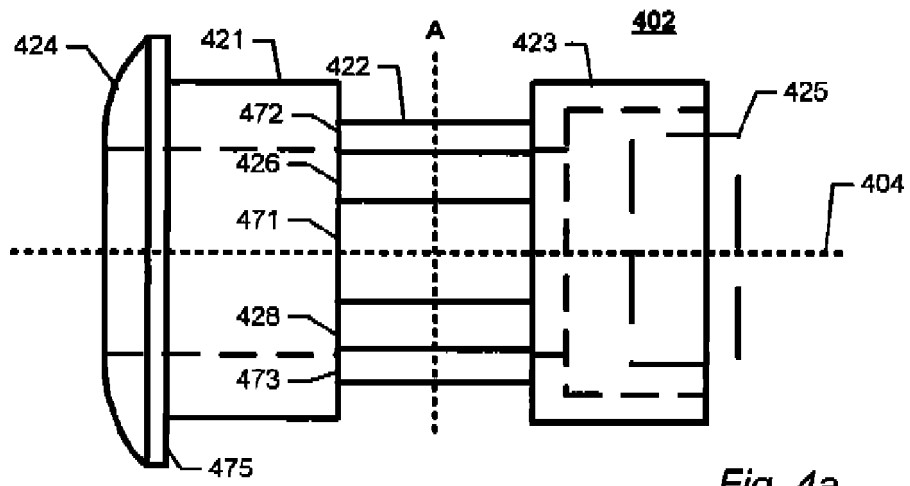


Fig. 4a

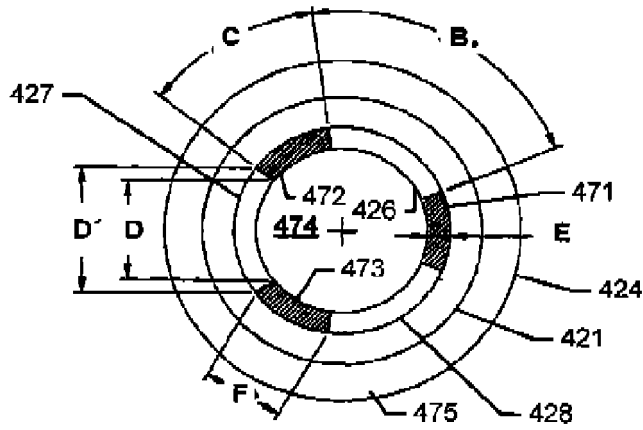


Fig. 4b

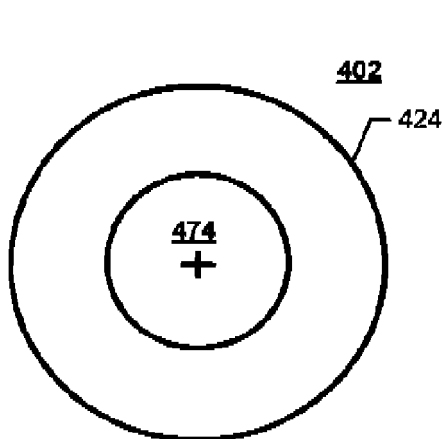


Fig. 4c

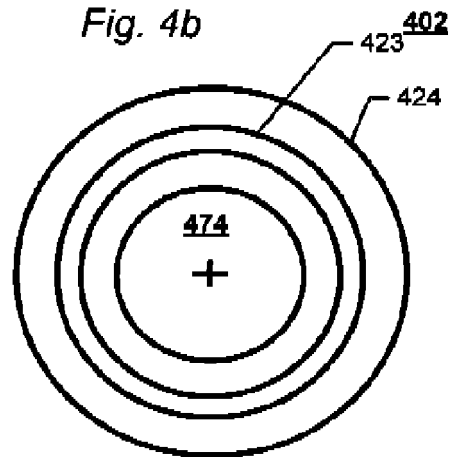


Fig. 4d

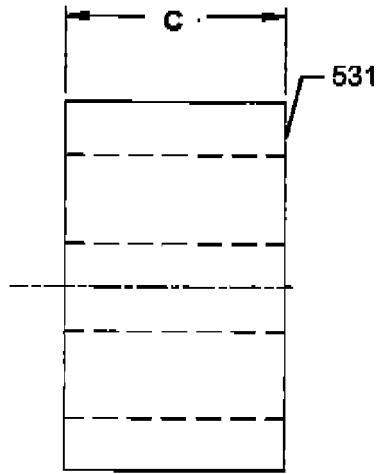


Fig. 5a

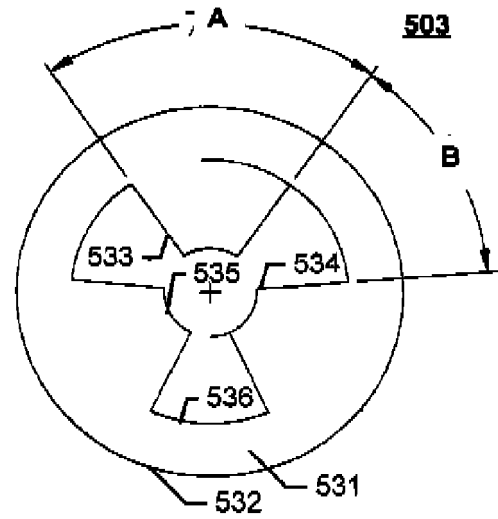


Fig. 5b

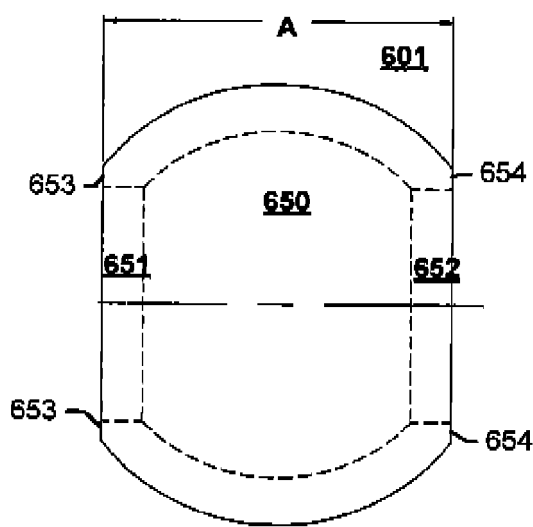


Fig. 6a

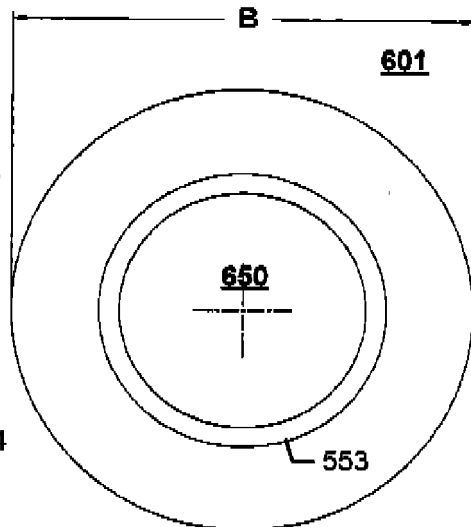
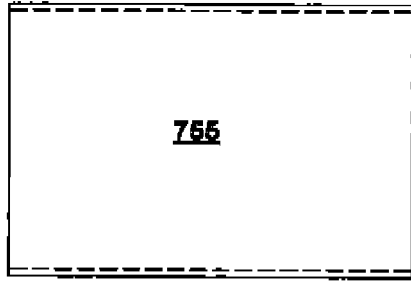


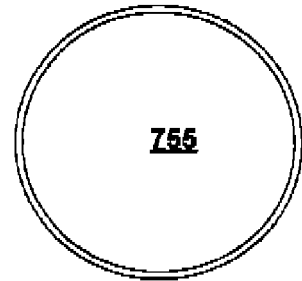
Fig. 6b

**705**

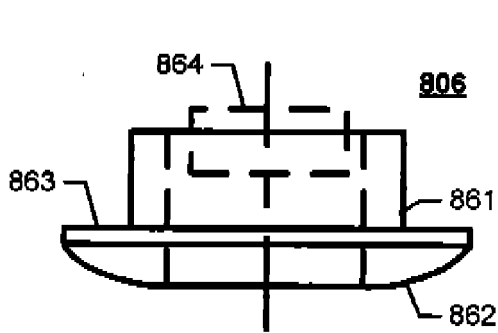


*Fig. 7a*

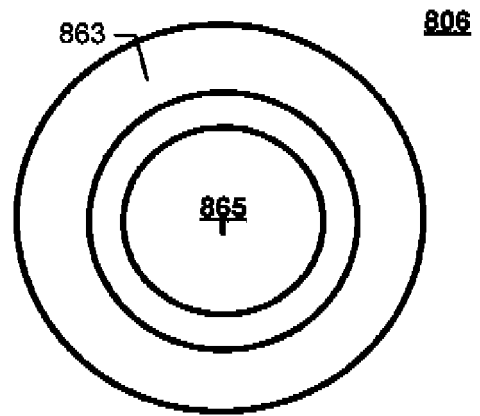
**705**



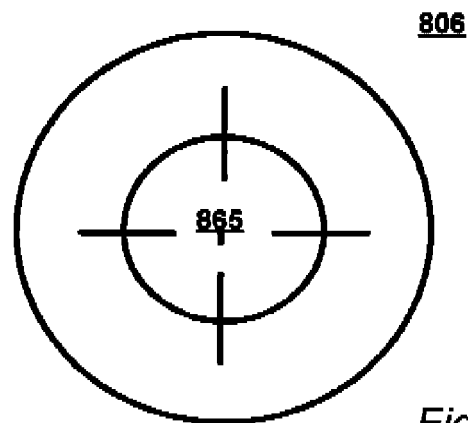
*Fig. 7b*



*Fig. 8a*



*Fig. 8b*



*Fig. 8c*

900

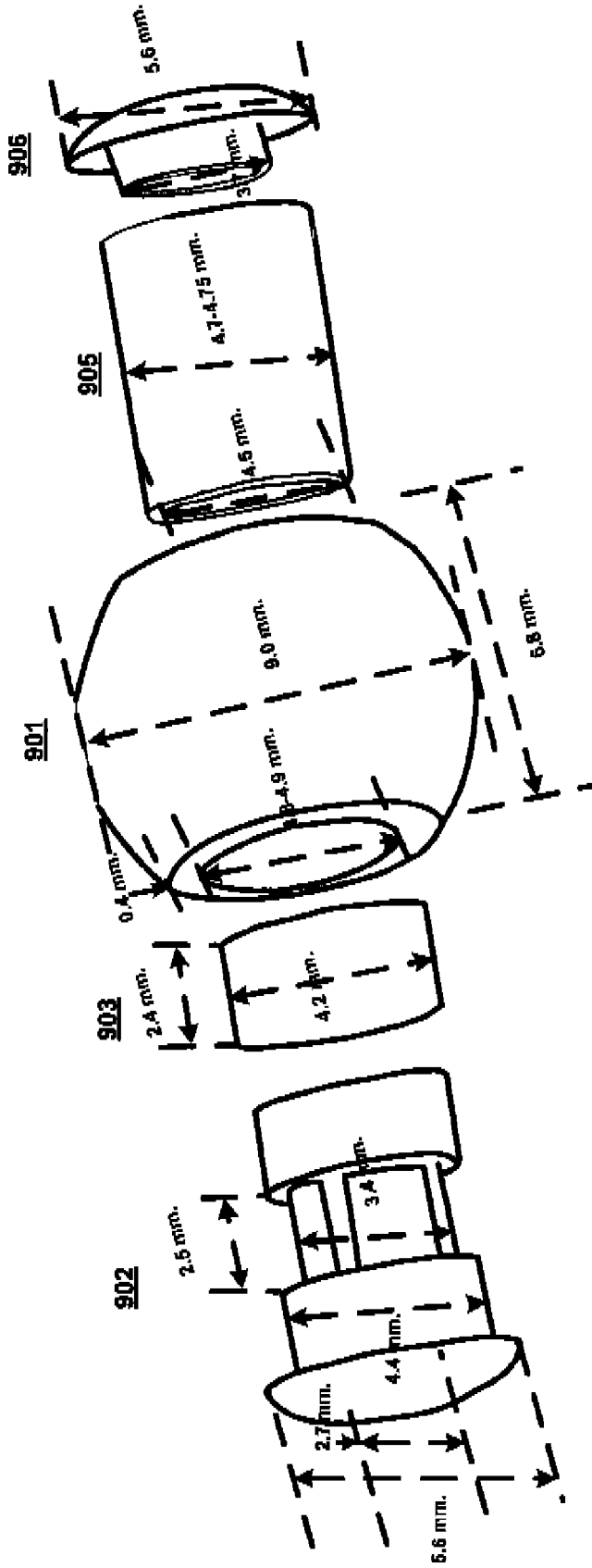


Fig. 9

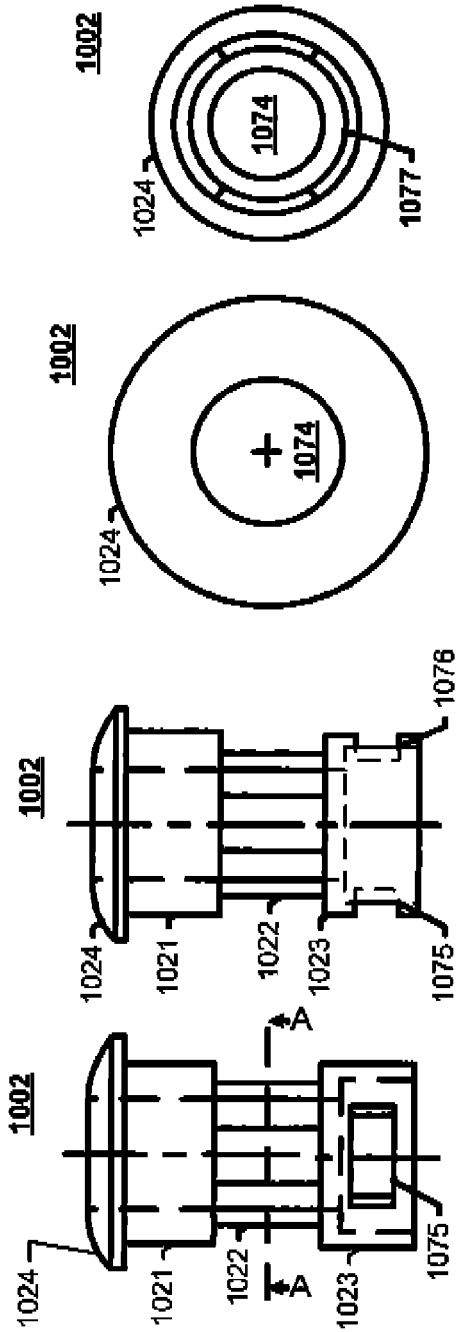


Fig. 10a

Fig. 10b

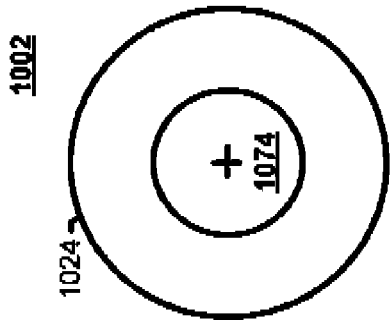


Fig. 10c

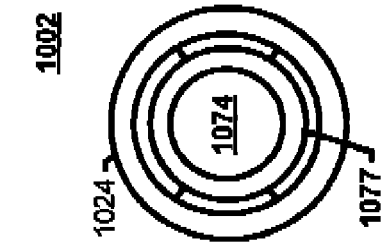


Fig. 10d

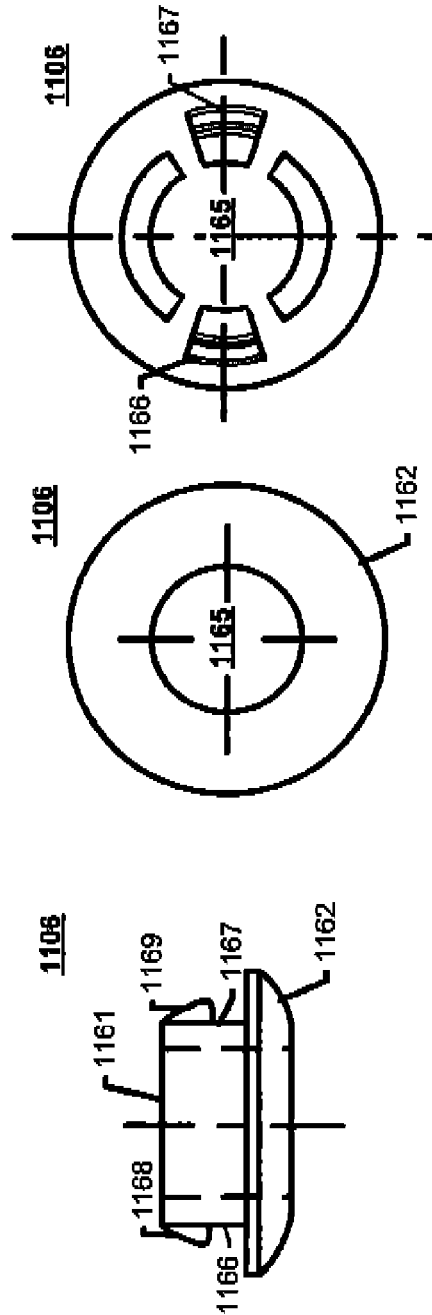


Fig. 11a

Fig. 11b

Fig. 11c

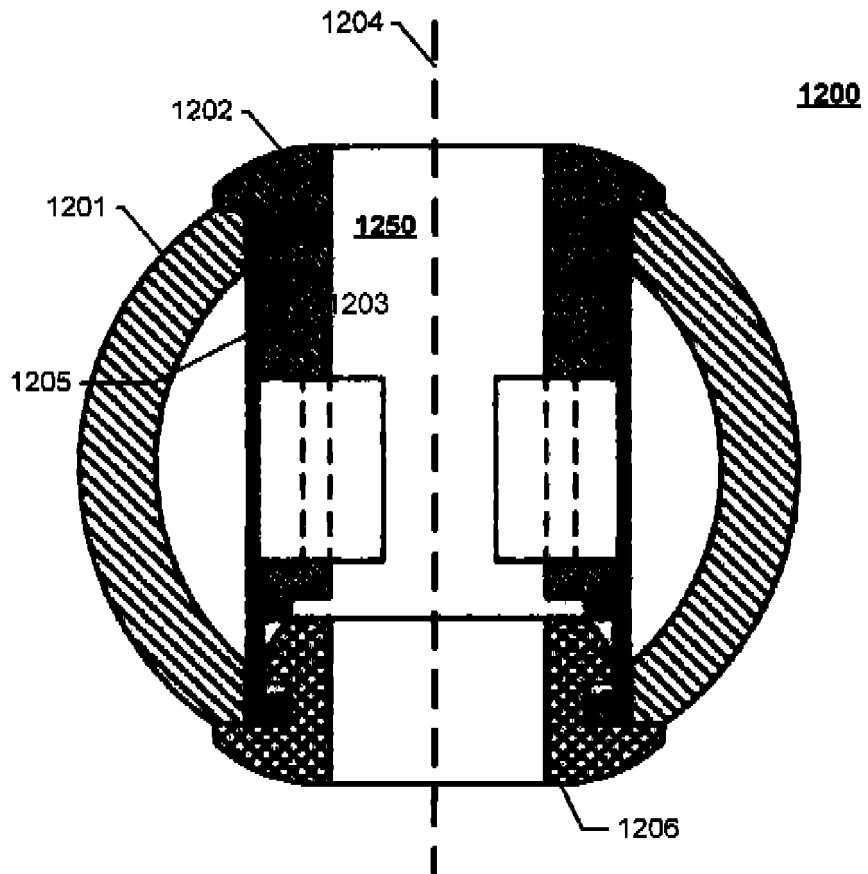


Fig. 12

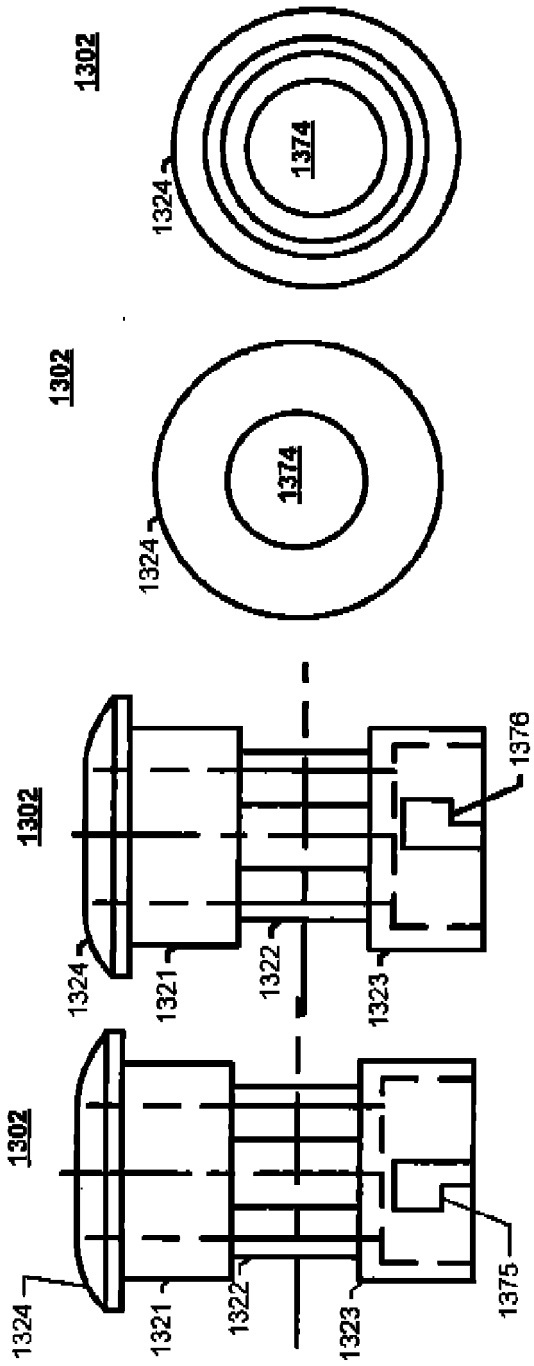


Fig. 13a

Fig. 13b

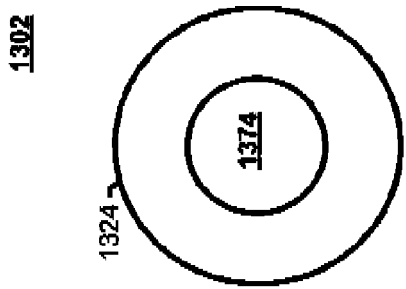


Fig. 13c

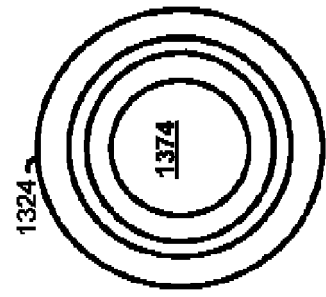


Fig. 13d

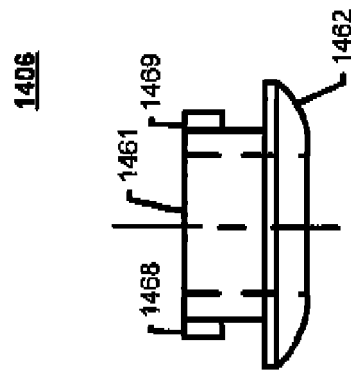


Fig. 14a

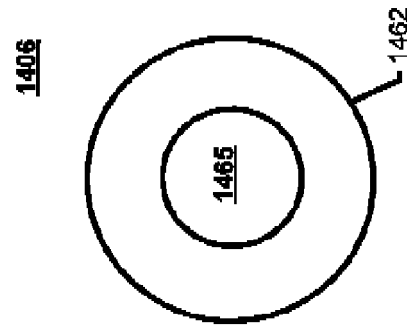


Fig. 14b

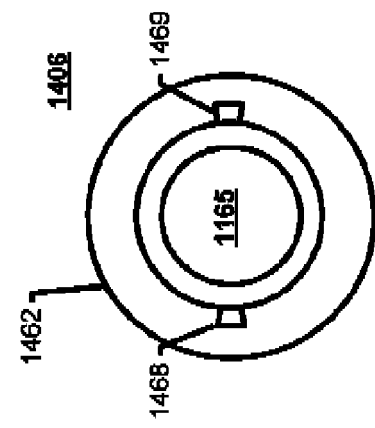


Fig. 14c

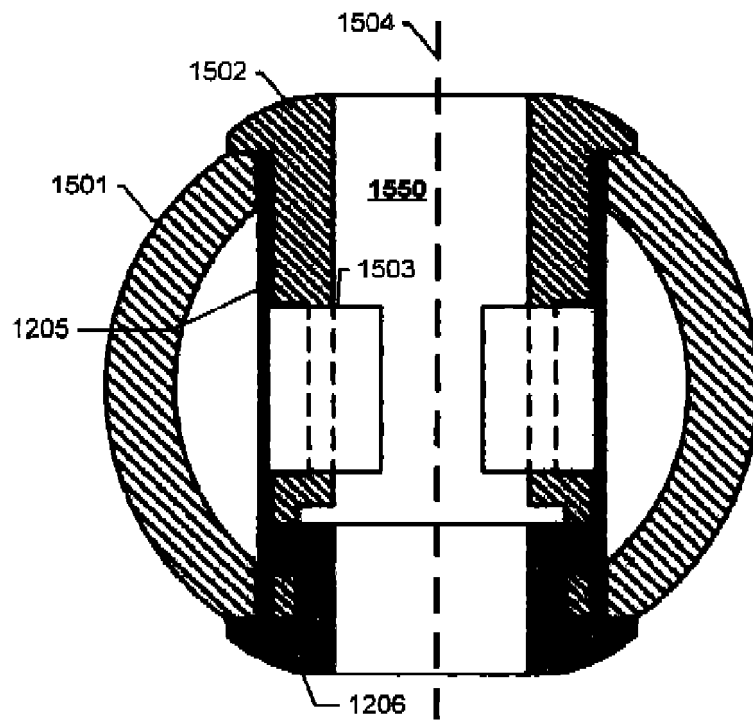


Fig. 15

**REFERENCES CITED IN THE DESCRIPTION**

*This list of references cited by the applicant is for the reader's convenience only. It does not form part of the European patent document. Even though great care has been taken in compiling the references, errors or omissions cannot be excluded and the EPO disclaims all liability in this regard.*

**Patent documents cited in the description**

- US 20030154742 A [0003]
- US 20020148250 A [0003]
- US 20060277945 A [0004]
- WO 2006125155 A [0005]