

ORGANISATION AFRICAINE DE LA PROPRIETE INTELLECTUELLE
(O.A.P.I.)



19

11 N°

12469

51 Inter. Cl.⁷

E21B 17/046, 17/042, 17/08

BREVET D'INVENTION

21 Numéro de dépôt : 1200300306

22 Date de dépôt : 22.05.2002

30 Priorité(s) : EP
24.05.2001 N° 01 304604.0

24 Délivré le : 23.04.2004

45 Publié le : 01 JUIN 2006

73 Titulaire(s) :

Société dite : SHELL INTERNATIONALE
RESEARCH MAATSCHAPPIJ B.V.
Carel Van Bylandtlaan 30
2596 HR LA HAYE (NL)

72 Inventeur(s) :

1- LOHBECK Wilhelmus Christianus Maria
Volmerlaan 8
2288 GD RIJSWIJK (NL)
2- MARKETZ Franz (NL)
3- NIJVELD Erik Marco (NL)
4- WUBBEN Antonius Leonardus Maria (NL)

74 Mandataire : CABINET CAZENAVE
B.P. 500
YAOUNDE - Cameroun

54 Titre : Radially expandable tubular with supported end portion.

57 Abrégé :

A method is provided of radially expanding a connector (24) for interconnecting a first tube (18) to a second tube (20), the connector including a pin member (26) extending into a box member (28). The pin and box members have cooperating support means (26, 28) arranged to support the pin member so as to prevent radially inward movement of said end portion of the pin member relative to the box member. The method comprises radially expanding the connector (24), and supporting the pin member so as to prevent radially inward movement of said end portion of the pin member relative to the box member.

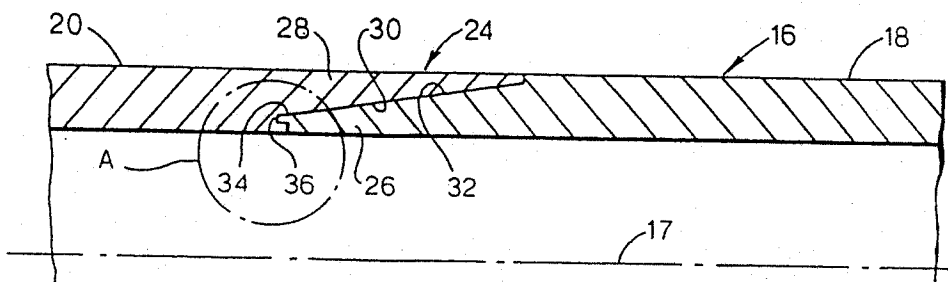

The present invention relates to a method of radially expanding a connector for interconnecting a first tube to a second tube, the connector including a pin member extending into a box member. Radially expanded tubular elements can be applied in numerous applications, such as in wellbore applications where hydrocarbon fluid is produced from an earth formation. For example, it has been tried to expand tubular wellbore casing in order to allow larger downhole wellbore diameters to be achieved compared to conventional wellbore construction wherein a plurality of casings are arranged in a nested arrangement. Such nested arrangement follows from the drilling procedure whereby for each newly drilled interval a new casing is lowered through the previously drilled and cased interval(s), which new casing therefore necessarily needs to be of smaller outer diameter than the inner diameter of the previously installed casing(s). This has been improved by radially expanding the new casing after having been lowered through the previously installed casing(s), whereby the new casing deforms plastically. The expanded casing allows passage therethrough of a larger diameter drill bit so that the wellbore can be further drilled at a larger diameter than in the conventional situation. A further casing is then lowered through the previously installed and expanded casing, and thereafter expanded, etc.

The end portion of an expanded tubular element, such as the end portion of the pin member of a connector, has a tendency to axially shorten due to the imposed circumferential strain in the wall of the pin member. The imposed circumferential strain at the inner surface is

larger than the imposed circumferential strain at the outer surface. This can be understood by considering that the circumferential strain at the inner surface is $\Delta D/D_i$ and the circumferential strain at the outer surface is $\Delta D/D_o$, and that D_i is smaller than D_o . Here D_i is the inner diameter of the pin member, D_o is the outer diameter of the pin member, and ΔD is the change in diameter due to the expansion process. Since the circumferential strain at the inner surface is larger than the circumferential strain at the outer surface, the tendency to shorten is larger at the inner surface than at the outer surface leading to a tendency of the pin member to bend radially inward. At locations remote from the end of the pin member, radially inward bending does not occur in view geometrical constraints. However, the end portion of the pin member does radially bend inwardly if no corrective measures are taken. Of course, the end portion of the box member also has a tendency to bend radially inward. However, inward bending of the box member end portion is less of a problem than inward bending of the pin member as the latter phenomenon causes an internal upset of the tubular element. Hence it will be understood that such radially inward bending of the pin member is a drawback in many applications of expanded tubulars.

It is an object of the invention to provide an improved method of radially expanding a tubular connector, which overcomes the aforementioned drawback.

In accordance with the invention there is provided a method of radially expanding a connector for interconnecting a first tube to a second tube, the connector including a pin member extending into a box member, the

pin and box members having cooperating support means arranged to support the pin member so as to prevent radially inward movement of said end portion of the pin member relative to the box member, the method comprising:

- radially expanding the connector; and
- supporting the pin member so as to prevent radially inward movement of said end portion of the pin member relative to the box member.

By supporting the pin member relative to the box member, it is achieved that inward radial movement of the pin member relative to the box member is prevented.

Suitably the pin member is supported so as to prevent said radially inward movement during and after radial expansion of the connector.

Since the pin member is prevented from inwardly bending during and after the expansion process, the pin member remains elastically deformed and therefore remains to have a tendency of inward bending. To prevent such inward bending of the pin member as a result of axial displacement of the pin member relative to the box member, it is preferred that the support means includes at least one support surface extending in substantially axial direction of the connector, each support surface being provided at one of the pin and box members. Thereby it is achieved that the axial support surface prevents inward bending irrespective of the axial position of the pin member relative to the box member.

Suitably the support surface is formed by a recess provided in one of the pin and box members, and wherein the other of the pin and box members extends into said recess.

Preferably the support means includes a first said support surface provided at the pin member and a second said support surface provided at the box member, the first support surface being supported by the second support surface.

To achieve a metal-to-metal seal between pin and box members it is preferred that the first and second support surfaces are compressed against each other as a result of radial expansion of the connector.

The invention will be described hereinafter in more detail and by way of example with reference to the accompanying drawing in which

Fig. 1 schematically shows a longitudinal section of an embodiment of a radially expanded tubular element not according to the invention;

Fig. 2 schematically shows a longitudinal section of an embodiment of a radially expanded tubular element according to the invention; and

Fig. 3 schematically shows detail A of Fig. 2.

Referring to Fig. 1 there is shown a tubular element 1 having longitudinal axis 2, after the tubular element has been elastically and plastically deformed by expansion in radial direction. The element 1 has an end portion 3 with a point 4 at the inner surface thereof and a point 6 at the outer surface thereof whereby the points 4, 6 are located at axial position Z. Point 4 is located at inner diameter 8 and point 6 at outer diameter 10 of the end portion 3. Ignoring any change of wall thickness of the tubular element 1 due to the expansion process, the magnitude of inner diameter 8 is $D_i + \Delta D$ and the magnitude of outer diameter 10 is $D_o + \Delta D$ wherein

D_i = inner diameter of the tubular element before expansion;

D_o = outer diameter of the tubular element before expansion;

ΔD = increase of the inner and outer diameter of the tubular element due to the expansion process.

The radial expansion process induces positive circumferential strain (also referred to as hoop strain) in the wall material of the tubular element 1. Since the volume of the wall material remains substantially constant during the deformation process, this leads to negative strain in the wall material in radial and/or axial direction. The circumferential strain at point 4 due to the expansion process is $\Delta D/D_i$ and the circumferential strain at point 6 due to the expansion process is $\Delta D/D_o$. Since D_o is larger than D_i it follows that the circumferential strain at point 4 is larger than the circumferential strain at point 6. Therefore, the wall material will undergo larger negative strain in radial and/or axial direction at the inner surface than at the outer surface. The larger negative axial strain at the inner surface induces the wall of end portion 3 to bend radially inwards, as schematically shown in Fig. 1. At locations remote from the end portion 3, the wall of the tubular element 1 does not radially bend inwards in view of geometrical constraints of the tubular element 1. At those locations the larger circumferential strain at the inner surface is compensated for by a larger negative radial strain at the inner surface than at the outer surface.

Referring to Figs. 2 and 3 there is shown a tube 16 having longitudinal axis 17 and formed of a first tubular element 18 and a second tubular element 20. The tubular elements 18, 20 are connected to each other by a pin/box connector 24 including a pin member 26 being an end portion of the first tubular element 18, and a box member 28 being an end portion of the second tubular element 20. The pin member 26 and the box member 28 have respective tapered contact surfaces 30, 32. The pin member 26 has a nose section 34 which extends into a recess provided in the box member 28, the recess being an annular groove 36 provided in a radially extending surface 38 of the box member 28. By this arrangement the pin member 26 is locked relative to the box member 28 with respect to radial displacement of the pin member 26 relative the box member 28.

During normal operation the tube 16 is radially expanded, for example by pulling or pumping an expander through the tube 16. As explained with reference to Fig. 1 the pin member 26 being an end portion of tubular element 18, and the box member 28 being an end portion of tubular element 20, will tend to bend radially inwards due to the expansion process. However, radially inward bending of the pin member 26 is prevented by virtue of nose section 34 of the pin member 26 being locked into the annular groove 36 of the box member 28. Thus, the pin member 26 remains flush with the inner surface of the tube 16.

In addition, a metal-to-metal seal is obtained between the nose section 34 and the wall of the groove 36 since the tendency of the pin member 26 to bend radially

inwards firmly pushes the nose section 34 against the wall of the groove 36.

5 Furthermore, a second metal-to-metal seal is possibly obtained between the respective contact surfaces 30, 32 due to the tendency of the pin member 26 to bend radially inward and the action of the annular groove 36 to prevent such radially inward bending.

10 Also, a third metal-to-metal seal is obtained between the respective contact surfaces 30, 32 close to the tip of the box member 28 due to the tendency of the box member 28 to bend radially inward and the action of the pin member 26 prevent such radially inward bending.

15 To enhance the holding power of the connector 24 and to further reduce the tendency of the pin member 26 to bend radially inwards, a layer of adhesive (e.g. an epoxy based adhesive) can be applied between the pin member 26 and the box member 28 so as to glue the pin and box members to each other.

20 The expanded tube can be a tube extending into a wellbore for the production of hydrocarbon fluid, for example a wellbore casing or a production tubing.

C L A I M S

1. A method of radially expanding a connector for interconnecting a first tube to a second tube, the connector including a pin member having an end portion near an open end of the pin member, the pin member
5 extending into a box member, the pin and box members having cooperating support means arranged to support the pin member so as to prevent radially inward movement of said end portion of the pin member relative to the box member, the method comprising:

10 - radially expanding the connector; and
- supporting the pin member so as to prevent radially inward movement of said end portion of the pin member relative to the box member, characterized in that the pin member is supported so as to prevent said radially inward
15 movement during and after radial expansion of the connector.

2. The method of claim 1, wherein the support means includes at least one support surface extending in substantially axial direction of the connector, each
20 support surface being provided at one of the pin and box members.

3. The method of claim 2, wherein the support surface is formed by a recess provided in one of the pin and box members, and wherein the other of the pin and box members
25 extends into said recess.

4. The method of claim 2 or 3, wherein the support means includes a first said support surface provided at the pin member and a second said support surface provided at the

box member, the first support surface being supported by the second support surface.

5 5. The method of claim 4, wherein the first and second support surfaces are compressed against each other due to radial expansion of the connector.

6. The method of any one of claims 3-5, wherein the recess is formed in the box member and wherein the pin member extends into the recess.

10 7. The method of claim 6, wherein said recess is an annular groove provided in a radially extending surface of the box member.

8. The method of any one of claims 1-7, wherein the support means includes a layer of adhesive arranged
15 between the pin member and the box member so as to glue the pin and box members to each other.

9. The method of any one of claims 1-8, wherein the connector is part of a radially expanded tubular element extending into a wellbore.

20 10. The method of claim 9, wherein connector is part of a radially expanded wellbore casing.

Fig.1.

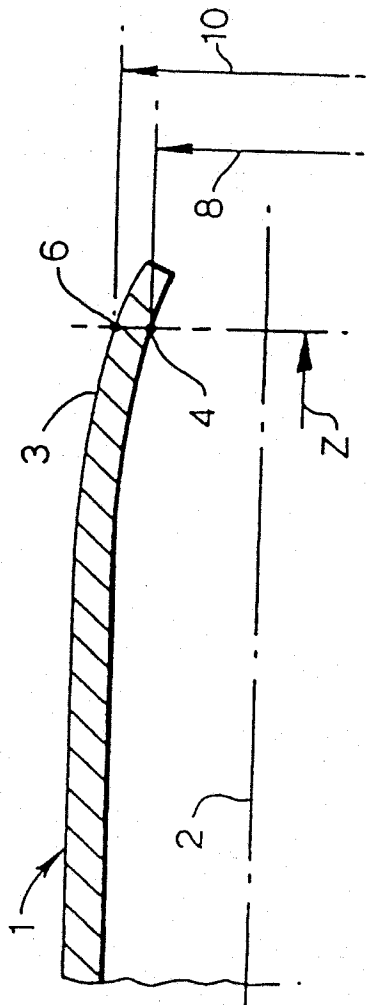

Fig.3.

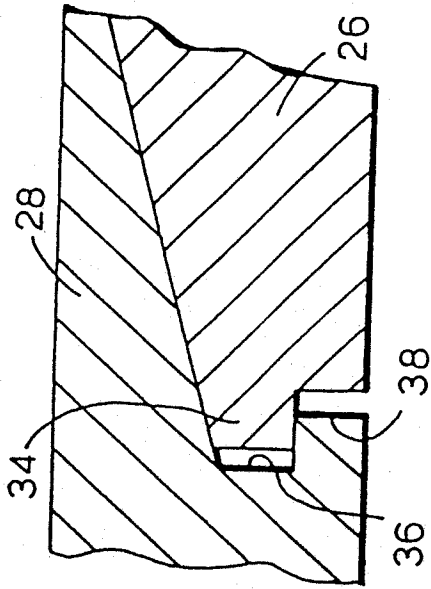

Fig.2.

