

L. ROYER.  
Grain Separator.

No. 101,664.

Patented April 5, 1870.

*Fig. 1.*

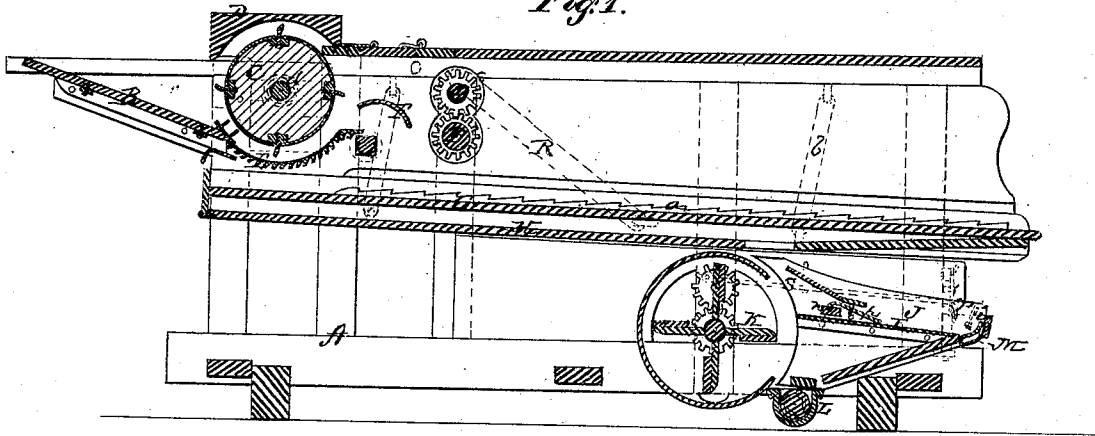

*Fig. 2.*

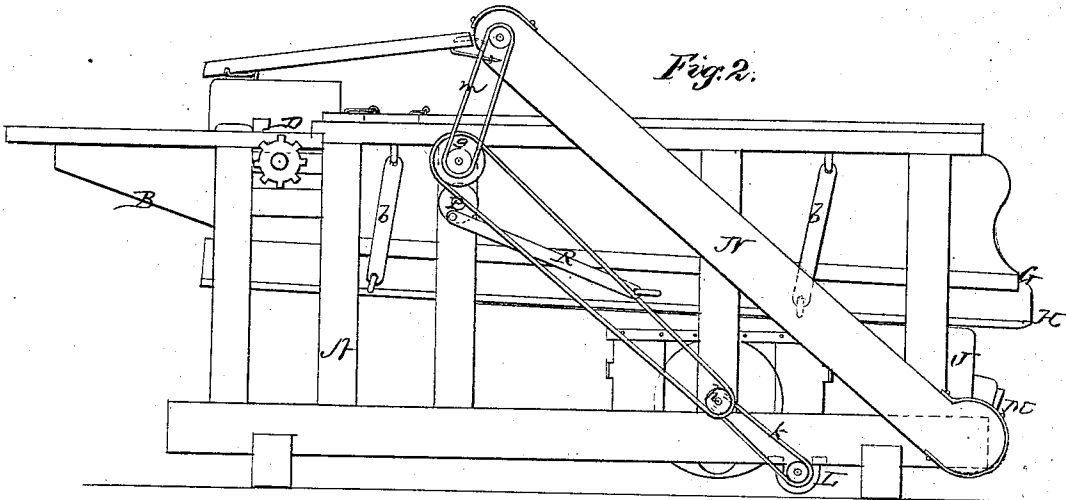

Witnesses  
Jno. A. Ellis.  
J. D. White

Inventor  
Lewis Royer  
Per.  
J. H. Alexander  
Atty.

# UNITED STATES PATENT OFFICE.

LEWIS ROYER, OF ROYERTON, INDIANA.

## IMPROVEMENT IN GRAIN-SEPARATORS.

Specification forming part of Letters Patent No. 101,664, dated April 5, 1870.

*To all whom it may concern:*

Be it known that I, LEWIS ROYER, of Royerton, in the county of Delaware and State of Indiana, have invented certain new and useful Improvements in Grain-Separators; and I do hereby declare that the following is a full, clear, and exact description thereof, reference being had to the accompanying drawings, and to the letters of reference marked thereon, which form a part of this specification.

The nature of my invention consists in the construction and general arrangement of a grain-separator, as will be hereinafter fully set forth.

In order to enable others skilled in the art to which my invention appertains to make and use the same, I will now proceed to describe its construction and operation, referring to the annexed drawings, in which—

Figure 1 is a longitudinal vertical section, and Fig. 2 a side elevation, of my machine.

A represents the frame of my machine, made of suitable dimensions, and having at one end an inclined board, B, for feeding the machine. In rear of this board is a toothed cylinder, *c*, and concave D, of the kind in common use, under which is attached a grate, E, which allows the grain to pass from the cylinder. Immediately in rear of the cylinder is a straw-director, F, of concave form, which directs the straw from the cylinder to the beater. The straw passing over the director F falls down on the shaker G, with which the grain-receiver H is combined. The shaker may be made of wood or iron, or both combined, and constructed as follows: The floor is perforated with numerous holes, which are countersunk, to facilitate the passage of the grain through them. These holes are placed in zigzag form, in order that all the grain will readily pass through. Immediately over the shoe the holes are more numerous, and these holes answer the purpose of a riddle; or a common riddle may be substituted if desirable. A series of slats, *a a*, are placed lengthwise on the shaker, running its entire length, and projecting about two inches above the floor. The upper edge of the slats *a a* are toothed to facilitate the passage of the straw over the same. The grain-receiver H is com-

bined with and actually forms a part of the shaker, and is placed immediately under the floor of the shaker.

The grain falls down from the shaker onto the grain-receiver, and is conveyed to the fan-mill by the motion of the shaker through an aperture in the receiver.

The fan-mill consists of the usual shoe, J, with one or more screws, I, and a fan, K, for separating the dust. The grain, after passing through the screen or screens I I, is passed out at either side of the machine through spouts L, and the grain that does not fall through the screens passes through the spout M into the elevator N at the side of the machine, from whence it is carried up to the inclined board B, and again passed through the machine.

The shaker G and receiver H are combined by means of iron rods passing through under the floor. The ends of said rods pass through plates, which secure the several parts together, and are held in position by hangers *b b*, attached to said rods, and may be raised and lowered at pleasure by means of screws on the upper ends of the hangers.

Motion is communicated to the shaker by means of a belt passing over a pulley, *d*, on the cylinder-shaft, thence to a pulley, *e*, on the main shaft O. Attached to said main shaft is a pinion, which gears with a larger cog-wheel upon the crank-shaft P, thus giving motion to the same. The gearing on the shafts O and P is susceptible of being attached either on the inside, as shown, or on the outside, as may be desired. A wrist-pin is placed in the cog-wheel on the shaft P when the gearing is on the outside, to which is attached a pitman, R, which drives the shaker. When the gearing is on the inside, the pitman R is attached to a crank on the end of the shaft P, as represented in the drawings.

Motion is given to the fan-shaft by a second pulley, *g*, on the main shaft O, from which a belt reaches around a pulley, *h*, on the fan-shaft. The shoe J, the front end of which rests upon a pivot, to avoid friction obtains its motion by a pitman, S, attached to a crank on a small shaft that passes through the frame A, and is within said frame provided with a cog-wheel, which gears with a pinion on the

fan-shaft. The other end of the pitman is attached to a bent lever, T, on the side of the frame, and this bent lever is by a rod, *i*, connected with the shoe. In the inner end of the shoe J is placed a cross-bar, *n*, to which a series of rake-teeth, *p p*, are loosely attached, said teeth passing through loops *o o* in the shoe. When the shoe vibrates, the ends of the bar *n* strike springs placed in the sides of the frame A, causing the teeth *p p* to vibrate from side to side.

In the spouts L L, under the shoe, is a worm or screw for conducting the grain to either side of the machine. This screw is operated by a belt, *k*, from a pulley on the fan-shaft, and by changing this belt from a straight to a twisted, or vice versa, the grain is carried to either side desired.

The device in the elevator N is operated by

means of a belt, *m*, from a pulley on the main shaft, as shown in Fig. 2.

Having thus fully described my invention, what I claim as new, and desire to secure by Letters Patent, is—

1. The combination of director F with cylinder C, substantially as and for the purpose set forth.

2. Rollers O P, shaker G, pitman R, straw-director F, and cylinder G, all combined substantially as and for the purpose described.

In testimony that I claim the foregoing as my own I affix my signature in presence of two witnesses.

LEWIS ROYER.

Witnesses:

JOHN A. ELLIS,  
J. V. WHITE.