

**(12) STANDARD PATENT**  
**(19) AUSTRALIAN PATENT OFFICE**

(11) Application No. **AU 2005236397 B2**

(54) Title  
**Step air foil**

(51) International Patent Classification(s)  
**F26B 9/00** (2006.01)                      **F26B 13/06** (2006.01)  
**F26B 11/02** (2006.01)                      **F26B 13/20** (2006.01)  
**F26B 13/00** (2006.01)

(21) Application No: **2005236397**                      (22) Date of Filing: **2005.02.23**

(87) WIPO No: **WO05/103592**

(30) Priority Data

(31) Number	(32) Date	(33) Country
<b>10/823,299</b>	<b>2004.04.13</b>	<b>US</b>

(43) Publication Date: **2005.11.03**

(44) Accepted Journal Date: **2010.07.22**

(71) Applicant(s)  
**Megtec Systems, Inc.**

(72) Inventor(s)  
**Rocheleau, Michael O.**

(74) Agent / Attorney  
**Phillips Ormonde Fitzpatrick, 367 Collins Street, Melbourne, VIC, 3000**

(56) Related Art  
**US 3763571 A**  
**US 4308984 A**

(19) World Intellectual Property  
Organization  
International Bureau



(43) International Publication Date  
3 November 2005 (03.11.2005)

PCT

(10) International Publication Number  
**WO 2005/103592 A1**

(51) International Patent Classification<sup>7</sup>: **F26B 13/00**,  
13/06, 9/00

(21) International Application Number:  
PCT/US2005/005606

(22) International Filing Date: 23 February 2005 (23.02.2005)

(25) Filing Language: English

(26) Publication Language: English

(30) Priority Data:  
10/823,299 13 April 2004 (13.04.2004) US

(71) Applicant (for all designated States except US):  
**MEGTEC SYSTEMS, INC.** [US/US]; 830 Prosper  
Road, Deperre, WI 54115 (US).

(72) Inventor; and

(75) Inventor/Applicant (for US only): **ROCHELEAU,  
Michael, O.** [US/US]; 6427 Aspen Drive, Sobieski, WI  
54171 (US).

(74) Agent: **BITTMAN, Mitchell, D.**; Sequa Corporation, 3  
University Plaza, Hackensack, NJ 07601 (US).

(81) Designated States (unless otherwise indicated, for every  
kind of national protection available): AE, AG, AL, AM,

AT, AU, AZ, BA, BB, BG, BR, BW, BY, BZ, CA, CH, CN,  
CO, CR, CU, CZ, DE, DK, DM, DZ, EC, EE, EG, ES, FI,  
GB, GD, GE, GH, GM, HR, HU, ID, IL, IN, IS, JP, KE,  
KG, KP, KR, KZ, LC, LK, LR, LS, LT, LU, LV, MA, MD,  
MG, MK, MN, MW, MX, MZ, NA, NI, NO, NZ, OM, PG,  
PH, PL, PT, RO, RU, SC, SD, SE, SG, SK, SL, SM, SY, TJ,  
TM, TN, TR, TT, TZ, UA, UG, US, UZ, VC, VN, YU, ZA,  
ZM, ZW.

(84) Designated States (unless otherwise indicated, for every  
kind of regional protection available): ARIPO (BW, GH,  
GM, KE, LS, MW, MZ, NA, SD, SL, SZ, TZ, UG, ZM,  
ZW), Eurasian (AM, AZ, BY, KG, KZ, MD, RU, TJ, TM),  
European (AT, BE, BG, CH, CY, CZ, DE, DK, EE, ES, FI,  
FR, GB, GR, HU, IE, IS, IT, LT, LU, MC, NL, PL, PT, RO,  
SE, SI, SK, TR), OAPI (BF, BJ, CF, CG, CI, CM, GA, GN,  
GQ, GW, ML, MR, NE, SN, TD, TG).

**Declarations under Rule 4.17:**

— as to applicant's entitlement to apply for and be granted  
a patent (Rule 4.17(ii)) for the following designations AE,  
AG, AL, AM, AT, AU, AZ, BA, BB, BG, BR, BW, BY, BZ,  
CA, CH, CN, CO, CR, CU, CZ, DE, DK, DM, DZ, EC, EE,  
EG, ES, FI, GB, GD, GE, GH, GM, HR, HU, ID, IL, IN, IS,  
JP, KE, KG, KP, KR, KZ, LC, LK, LR, LS, LT, LU, LV, MA,  
MD, MG, MK, MN, MW, MX, MZ, NA, NI, NO, NZ, OM,

[Continued on next page]

(54) Title: STEP AIR FOIL

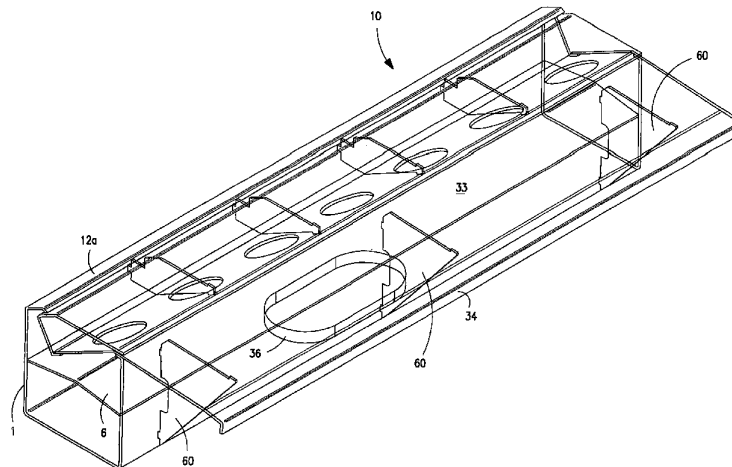

(57) Abstract: Step air foil particularly for one-sided flotation of a running web, and web dryer incorporating the same. The air foil includes two discharge slots which allow for increased draw down force, which flattens machine direction wrinkles in a floating web. The air foil includes a primary discharge slot and a second discharge slot spaced from and stepped down from the primary discharge slot, a first web support surface between the primary discharge slot and the secondary discharge slot, and a second web support surface downstream of the secondary discharge slot in the direction of web travel. The air foil is in communication with an air supply which provides a supply of air that is uniformly distributed to the primary and secondary slots. Air discharged from the primary slot is gathered into the air stream of the secondary slot and creates an increased air cushion to provide greater support to the moving web and thereby remove machine direction web wrinkles caused by higher tension in light weight webs.



WO 2005/103592 A1



PG, PH, PL, PT, RO, RU, SC, SD, SE, SG, SK, SL, SM, SY, TJ, TM, TN, TR, TT, TZ, UA, UG, UZ, VC, VN, YU, ZA, ZM, ZW, ARIPO patent (BW, GH, GM, KE, LS, MW, MZ, NA, SD, SL, SZ, TZ, UG, ZM, ZW), Eurasian patent (AM, AZ, BY, KG, KZ, MD, RU, TJ, TM), European patent (AT, BE, BG, CH, CY, CZ, DE, DK, EE, ES, FI, FR, GB, GR, HU, IE, IS, IT, LT, LU, MC, NL, PL, PT, RO, SE, SI, SK, TR), OAPI patent (BF, BJ, CF, CG, CI, CM, GA, GN, GQ, GW, ML, MR, NE, SN, TD, TG)

— as to the applicant's entitlement to claim the priority of the earlier application (Rule 4.17(iii)) for all designations

**Published:**

— with international search report

For two-letter codes and other abbreviations, refer to the "Guidance Notes on Codes and Abbreviations" appearing at the beginning of each regular issue of the PCT Gazette.

**STEP AIR FOIL**  
**FIELD OF THE INVENTION**

5 The present invention relates to devices for contactlessly drying and guiding travelling webs.

**BACKGROUND OF THE INVENTION**

10 A reference herein to matter which is given as prior art is not to be taken as an admission that that matter was, in Australia, known or that the information it contains was part of the common general knowledge as at the priority date of any of the claims.

15 In web coating, printing and drying operations, it is often desirable that the web have contactless support, in order to avoid damage to the web itself or to the coating (such as ink) previously applied to one or more surfaces of the web. One arrangement of which the Applicant is aware for contactlessly supporting a web during drying includes horizontal upper and lower sets of air bars between which the web travels. Hot air issuing from the air bars both dries and supports the web as it travels through the dryer.

20 Important characteristics of any flotation system are the amount of cushioning provided by the flotation device, and the stability of the web as it passes over the device. Adequate support removes web wrinkles that typically are caused by higher tensions in lightweight webs. Airflow instabilities near the web can induce web flutter and subsequent web contact with mechanical parts of the dryer, resulting in coating disturbance or web damage. Web flutter can be  
25 manifested in a multitude of forms, ranging from a violent flapping of the web to a high frequency drumming.

30 Single slot air bars are known in the art as air foils. They differ from double and triple slot air bars in that they have both a positive and negative pressure on the face of the air bar, whereas the double and triple slotted bars have only positive pressure. As a result, double and triple slotted air bars can be operated over a wider range of pressures and clearances; typical flotation clearances of air foils being about 2.3 mm compared to 6.3 mm for double and triple air bars. Air foils also have a dramatic decrease in both heat transfer and flotation stability as clearance is increased, whereas the heat transfers for

double and triple air bars are relatively stable up to a clearance of 25 mm (single size bar). One application for single slot air bars is where flotation must be accomplished with air on only one side of the web.

5 The Applicant is aware of air foils which discharge air at about 45° to the web, which pushes the web up and relies on the flatness of the web to trap the air and force it to follow the air foil face. This creates a negative pressure to pull the web back down and hold it in place over the air foil. When floating lightweight webs under medium to high tensions, machine direction corrugations will form in the web. These corrugations allow the discharged air from the 45° slot to escape and not trap the air  
10 between the air foil face and the web, thereby reducing or eliminating the velocity created to draw the web down to the air foil face. This can result in poor flotation and can render the air foil ineffective.

15 It would be desirable to provide an air foil for floating a web that provides improved web support for a wide range of web weights, and provides improved web stability.

### **SUMMARY OF THE INVENTION**

20 According to the present invention there is provided an air foil for floating a web of material, including a primary discharge slot and a secondary discharge slot spaced from and stepped down from said primary discharge slot, said secondary discharge slot being downstream of said primary discharge slot in the direction of web travel, a first flat web support surface between said primary discharge slot and said secondary discharge slot, and a second web support surface downstream of said secondary discharge slot in the direction of web travel, wherein said secondary discharge slot  
25 discharges air parallel to the web

30 According to the present invention there is further provided a web dryer, including a web inlet and a web outlet spaced from said web inlet, a plurality of air discharge nozzles in said dryer for drying said web, and at least one air foil in said dryer, said air foil including a primary discharge slot and a secondary discharge slot spaced from and stepped down from said primary discharge slot, said secondary discharge slot being downstream of said primary discharge slot in the direction of web travel, a first flat web support surface between said primary discharge slot and said secondary discharge slot, and a second web support surface downstream of said

secondary discharge slot in the direction of web travel, wherein said secondary discharge slot discharges air parallel to the web.

5 The present invention can overcome difficulties associated with the prior art by providing a step air foil particularly for one-sided flotation of a running web, and a web dryer having one or more such air foils. The air foil design includes two discharge slots which may allow for increased draw down force, which flattens machine direction wrinkles in a floating web. The design does not rely on a flat web to help create a cross-face velocity to draw the web to the face for proper flotation. Air discharged from the primary slot is gathered into the air stream of the secondary slot and may  
10 create an increased air cushion to provide greater support to the moving web and thereby remove machine direction web wrinkles caused by higher tension in light weight webs. The two air discharge slots blow gas (air) parallel to the web over a longer area than prior art designs thereby increasing the draw down force against the web.

15 In use the air foil is in communication with an air supply which provides a supply of air that is uniformly distributed to the primary and secondary

slots.

The air foil can be primarily used for one sided flotation, but also can be used with two sided arrangements for enhancement of drying.

#### **BRIEF DESCRIPTION OF THE DRAWINGS**

Figure 1 is a cross-sectional view of an air foil in accordance with the present invention;

Figure 2 is a cross-sectional view of the header of the air foil of Figure 1;

Figure 3A is a top view of the trailing bottom plate of the air foil of the present invention;

Figure 3B is a cross-sectional view of the trailing bottom plate taken along line A-A of Figure 3A;

Figure 4 is a cross-sectional view of the trailing top plate of the air foil of the present invention;

Figure 5 is a cross-sectional view of a spacer for the air foil of the present invention;

Figure 6 is a perspective view of the air foil of the present invention;

Figure 7 is a cross-section view of a gusset for the air foil of the present invention; and

Figure 8 is a schematic view of a dryer having a plurality of air foils on one side of the web in accordance with an embodiment of the present invention.

## DETAILED DESCRIPTION OF THE INVENTION

2005236397 22 Sep 2006

The air foil of the present invention is a unique design that incorporates a secondary slot that can discharge air parallel to the web in order to maintain a constant pull down force that is independent of a flat web. It is particularly useful for one-sided flotation applications.

Turning now to Figure 1, there is shown an air foil in accordance with the preferred embodiment of the invention generally at 10. The air foil 10 is defined in part by a header 1, which in the embodiment shown, is generally rectangular in cross-section except for its top portion. As seen in Figure 2, opposite sides 11a, 11b of header 1 terminate in respective top flange portions 12a, 12b. Top flange portion 12a is angled, preferably at about 65° relative to vertical, and terminates in a bent portion 13. Top flange portion 12b extends towards opposite side 11a in a substantially horizontal fashion. The header 1 defines an interior space 5 that serves as a plenum for the gas that is received via the one or more holes 36 at the base of the air foil that are in gas-receiving communication with a gas supply (not shown). The header 1 is positioned on suitable ducting by aligning the aligners 8 at each end plate of the header and is sealed by retainer gasket 7. A diffuser plate 6 (Figure 1) having a plurality of spaced holes can be positioned in the header to help distribute the supply of gas evenly as it flows towards the slots. In the embodiment shown, the diffuser 6 has a pitch (about 15°) with an apex at or near the centreline CL of the header 1.

The flange portions 12a, 12b and bent portion 13 of header 1, together with the trailing top plate 2 and trailing bottom plate 3, define the primary and secondary slots of the air foil. Specifically, Figures 3A and 3B illustrate the trailing bottom plate 3 in greater detail. The plate 3 includes a relatively short portion 31 that has a plurality of spaced apertures 32a-32n formed therein. Preferably the apertures are circular and are evenly spaced to allow for even flow of gas from the plenum to the stepped-down secondary slot of the air foil, as discussed in greater detail below. In the embodiment shown, there are six such apertures, each about 2 inches in diameter, although those skilled in the art will appreciate that the present invention is not limited to any particular number or size aperture.

The plate 3 also includes a relatively long portion 33 that extends from the short portion 31 at an angle therefrom. The relatively long portion 33 forms the wing of the air foil, as best seen in Figure 6, and terminates in a downwardly extending flange 34. Preferably the relatively long portion 33 of the plate 3 extends from the short portion 31 at an angle of about  $28^\circ$ , bends an additional  $2-3^\circ$  towards the midpoint of the portion 33, and then bends an additional  $5^\circ$  about one inch from the flange 34. The flange 34 extends downwardly at a right angle about 0.5 inches. The plate 3, together with trailing top plate 2, defines the secondary slot S through which air flowing from the apertures 32a-32n is emitted. That air then travels along the top face of the wing in the direction of web travel.

Figure 4 illustrates the trailing top plate 2 in cross-section. The top plate 2 includes a flange 21 that connects to the end of the short portion 31 of the trailing bottom plate 3, such as by welding (see Figure 1). Extending from flange 21 is a first flat portion 22, a second flat portion 23 which extends from flat portion 22 at an angle of approximately  $90^\circ$ , and an elongated portion 24 that extends from second flat portion 23 at an angle of about  $27^\circ$ . When properly positioned in the header 1, the second flat portion 23 of the trailing top plate 3 defines with flange 13 of the header 1 the primary slot P, and the elongated portion 24 defines a top web support face of the air foil 10 (best seen in Figure 1) along which the air exiting from the primary slot P flows in the direction of web travel. Preferably the discharge opening of the primary slot P is about 0.08 inches.

The distance between the primary slot P and the secondary slot S is important for proper air flow and web flotation. If the distance is too small, the air issuing from the primary slot P will not flow parallel to the web. If the distance is too great, the primary slot airflow will lose its velocity. Preferably the distance between the slots is from about 2.5 inches to about 6.5 inches, with 3.25 inches particularly preferred.

Turning now to Figure 5, there is shown in cross-section a spacer 4. The spacer 4 is shaped to be received within the space defined by the top and bottom trailing plate assemblies.

Preferably a plurality of spacers 4 are positioned along the length of the air foil, and are positioned between the

apertures in the trailing bottom plate 3 so as not to interfere with the flow of gas emanating from the apertures 32a-32n. The spacing across the air foil length is not critical, as they merely form a truss system for strength. The cross-sectional shape of the spacers 4 matches the cross-section of the area defined by the trailing top and bottom plates 2 and 3, respectively. The spacers 4 can be secured in place by any suitable means, and are preferably secured via welding of the tab 47a to the header 1, tab 47b to the trailing top plate 2, and tab 47c to the trailing bottom plate 3. The spacer ends set the gap or opening size for the secondary slot S, which is preferably about 0.08 inches. The secondary slot S discharges air parallel to the web and maintains a constant air velocity across the flat face for maximum draw down force.

In order to adequately support the wing extension of the trailing bottom plate, a plurality of gussets 60 (Figure 7) are positioned beneath the wing as shown in Figure 6. Each gusset 60 attaches to the header 1 by suitable means, such as by welding at tabs 61a, 61b. Similarly, the top of the gusset 60 attaches to the underside of the wing via welding of tab 61c. The top of each gusset 60 is tapered to accommodate the slope of the wing. The number of gussets needed depends upon the length of the nozzle, and is within the skill in the art. In the embodiment shown in Figure 6, three evenly spaced gussets are provided.

As shown in Figure 8, the two discharge slots allow for effective one-sided web flotation of all weight webs, from thin films to heavier paper and films. A portion 100 of a web dryer

is shown, with a plurality of air foils 10, each in communication with an air supply header 101 and positioned on one side of the running web 200. Positioned on the opposite side of the running web 200 is a plurality of nozzles 105, each preferably located in a staggered relationship relative to the location of each air foil 10. In the embodiment shown, the opposing nozzles 105 in the step air foil zone of the dryer 100 are basic single slot nozzles with low velocity and high volume for solvent dilution to keep LFL levels low. A constant cross-face velocity draws the web to the air foil face to produce good flotation and web characteristics. The two-slot design allows for twice the draw down force, which in turn flattens the machine direction wrinkles in a floating web. The increased hold down force of the air foil creates a flat web for a stable transition into opposing air bar zones without web flutter, web billowing, or marking problems.

Thus, in operation, air flow is discharged through primary and secondary slots or orifices. The design allows for the reclamation of the discharged air from the primary slot to be gathered into the air stream of the secondary slot and create an increased air cushion to give greater support to the moving web, which in turn removes the machine direction web wrinkles caused by higher tensions in lighter weight webs.

A higher flotation height (e.g., a positive 0.125 inch flotation height off the air foil face regardless of line speed) is possible for higher tensioned webs. Because air is discharged below and parallel to the web, there is always a velocity across the air foil face to draw the corrugated web

5 down to the face and hold it in place for controlled transport. The increased cushion pressure of the secondary slot stretches the web, removing any machine direction wrinkles that may have formed in the web, thereby creating a glass-like appearance to the web. By incorporating two discharge slots on two different face locations and thus providing two large flat face areas, the draw down force is doubled, which is a necessity when flattening machine direction corrugation wrinkles.

10 The range of web weights and tension conditions with which the present invention exhibits improved flotation characteristics can be more than twice that of prior art designs.

The performance of the air foil allows for a larger spacing between air foils when installed in a dryer and allows for a greater window of operation with different web weights and web tensions. It can be used as a web-stabilizing device because of the strong web capturing characteristics of the design.

15 The invention described herein is susceptible to variations, modifications and/or additions other than those specifically described and it is to be understood that the invention includes all such variations, modifications and/or additions which fall within the spirit and scope of the above description.

THE CLAIMS DEFINING THE INVENTION ARE AS FOLLOWS:

1. An air foil for floating a web of material, including a primary discharge slot and a secondary discharge slot spaced from and stepped down from said primary discharge slot, said secondary discharge slot being downstream of said primary discharge slot in the direction of web travel, a first flat web support surface between said primary discharge slot and said secondary discharge slot, and a second web support surface downstream of said secondary discharge slot in the direction of web travel, wherein said secondary discharge slot discharges air parallel to the web.
2. The air foil of claim 1, wherein air discharged from said primary discharge slot is gathered into the air stream of said secondary discharge slot in a direction parallel to the web transport direction.
3. The air foil of claim 1 or 2, wherein said second web support surface includes a wing portion that slopes downwardly as its extend away from said secondary discharge slot.
4. The air foil of any one of claims 1 to 3, further including a diffuser for uniformly distributing air to said primary discharge slot and to said secondary discharge slot.
5. The air foil of any one of claims 1 to 4, wherein said second web surface is an elongated wing having a series of bends.
6. The air foil of claim 5, wherein one of said bends is at an angle of 30°.
7. The air foil of claim 5 or 6, wherein said elongated wing terminates in a downwardly extending flange.
8. The air foil of claim 6 or 7, wherein one of said bends is at an angle of 3°.
9. A web dryer, including a web inlet and a web outlet spaced from said web inlet, a plurality of air discharge nozzles in said dryer for drying said web, and at least one air foil in said dryer, said air foil including a primary discharge slot and a secondary discharge slot spaced from and stepped down from said primary discharge slot, said secondary discharge slot being downstream of said primary discharge slot in the direction of web travel, a first flat web support surface between said primary discharge slot and said secondary discharge slot, and a second web support surface downstream of said secondary discharge slot in the direction of web travel, wherein said secondary discharge slot discharges air parallel to the web.
10. The web dryer of claim 13, wherein there are a plurality of air foils in said dryer, all positioned on the same side of said web.

11. The web dryer of claim 9 or 10, wherein air discharged from said primary discharge slot is gathered into the air stream of said secondary discharge slot in a direction parallel to the web transport direction.

5 12. The web dryer of claim 9, 10 or 11, wherein said second web support surface includes a wing portion that slopes downwardly as it extends away from said secondary discharge slot.

13. The web dryer of any one of claims 9 to 12, wherein said second web support surface includes a bent plate.

10 14. The web dryer of claim 13, wherein said bent plate includes a plurality of apertures to allow air to flow to said secondary discharge slot.

15. An air foil according to any one of the embodiments substantially as herein described and illustrated.

16. A web dryer according to any one of the embodiments substantially as herein described and illustrated.

15

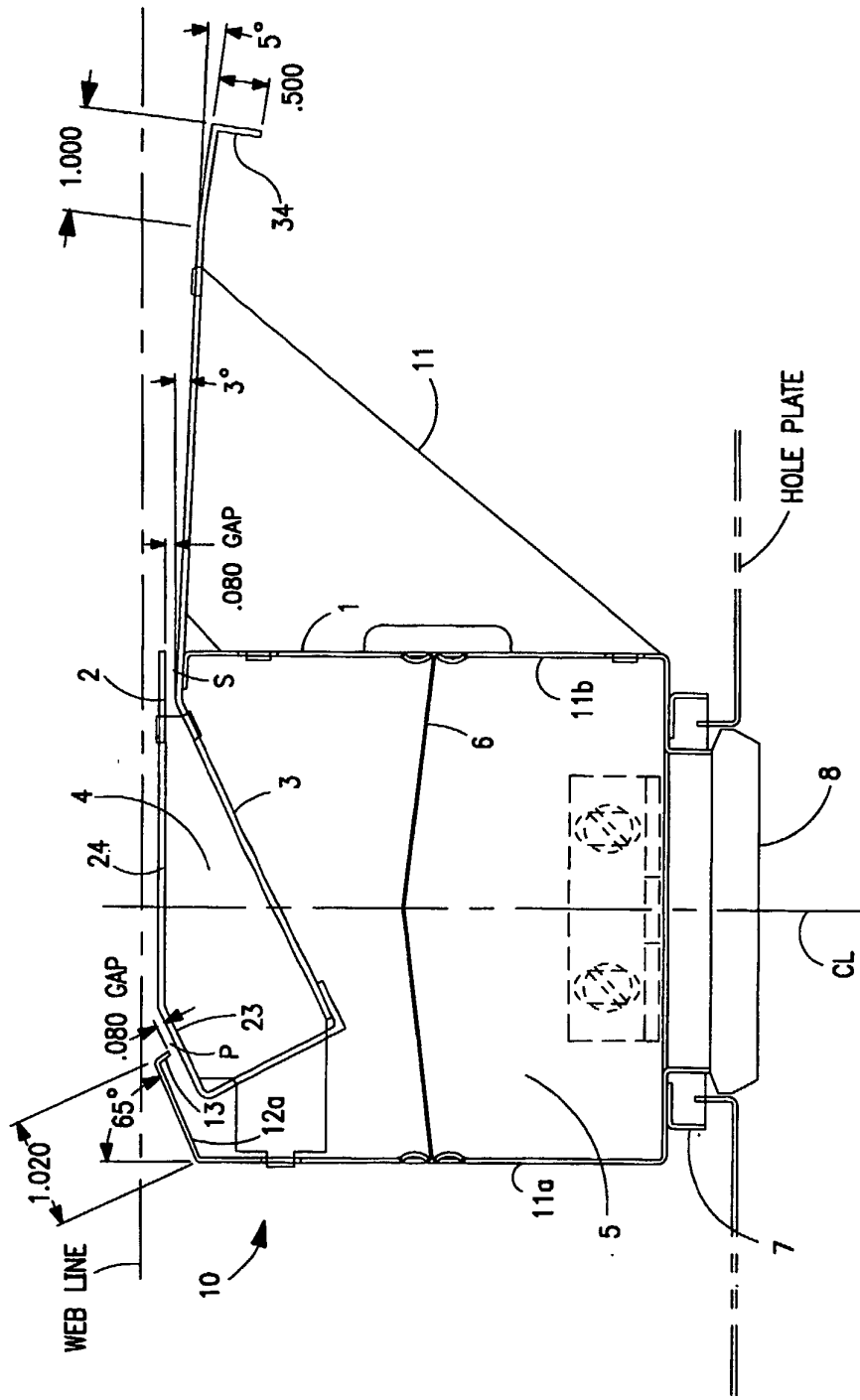

FIG. 1

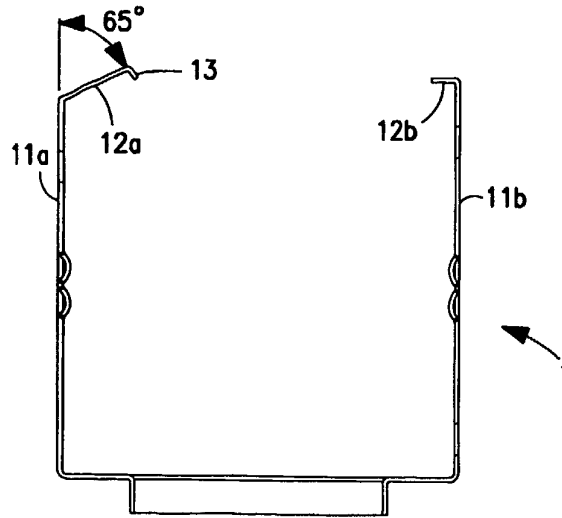

FIG. 2

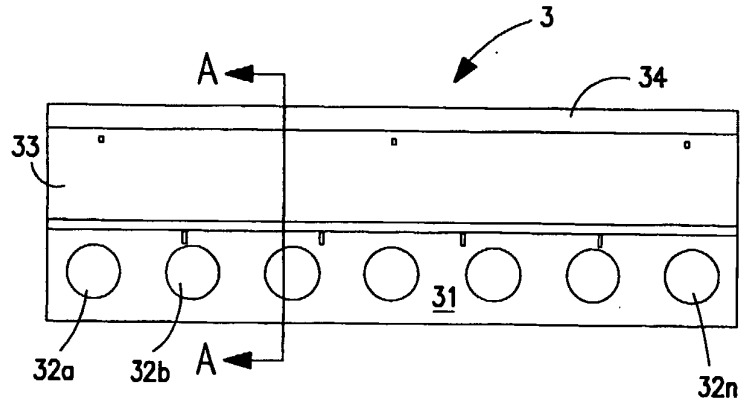

FIG. 3A

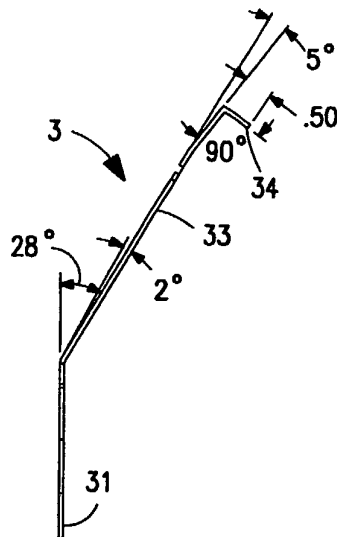
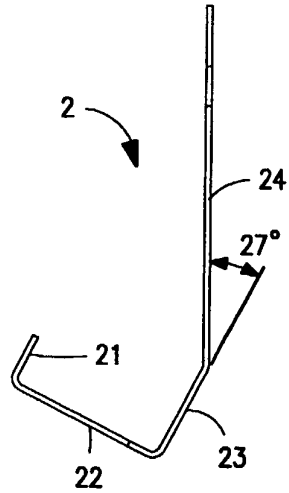
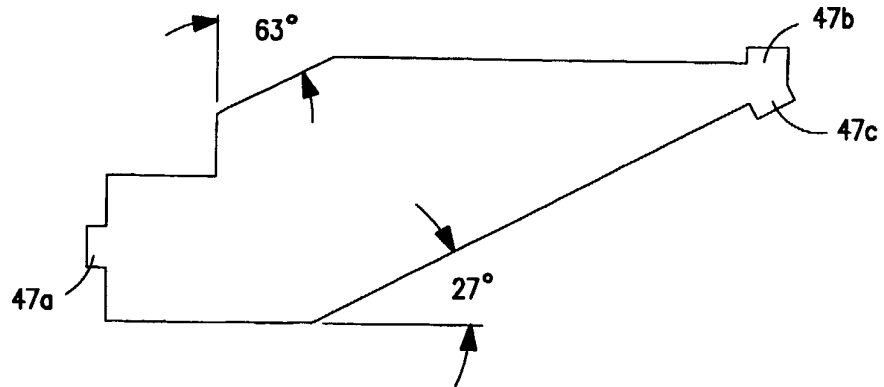

FIG. 3B

3/6



**FIG. 4**



**FIG. 5**

4/6

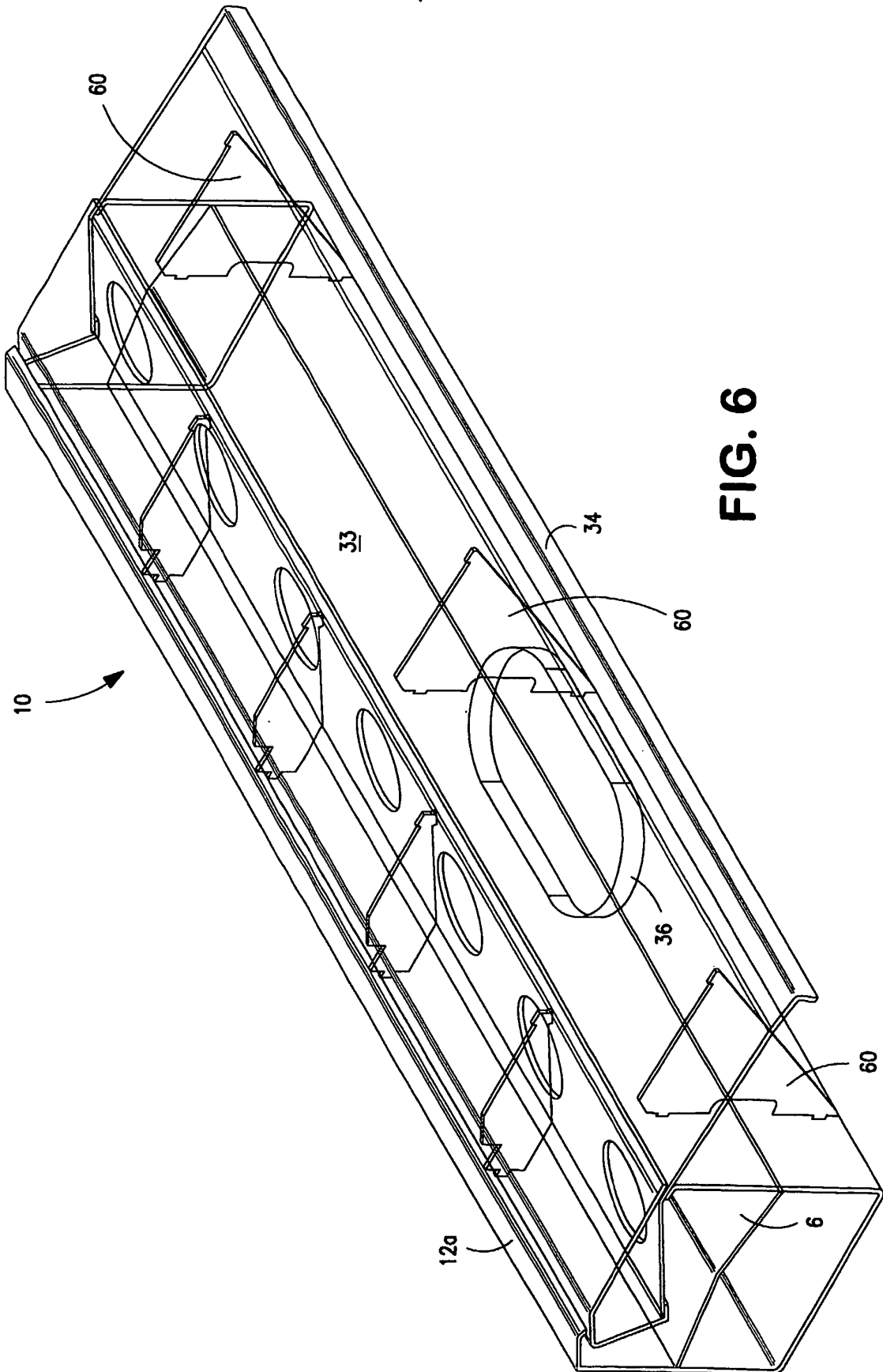
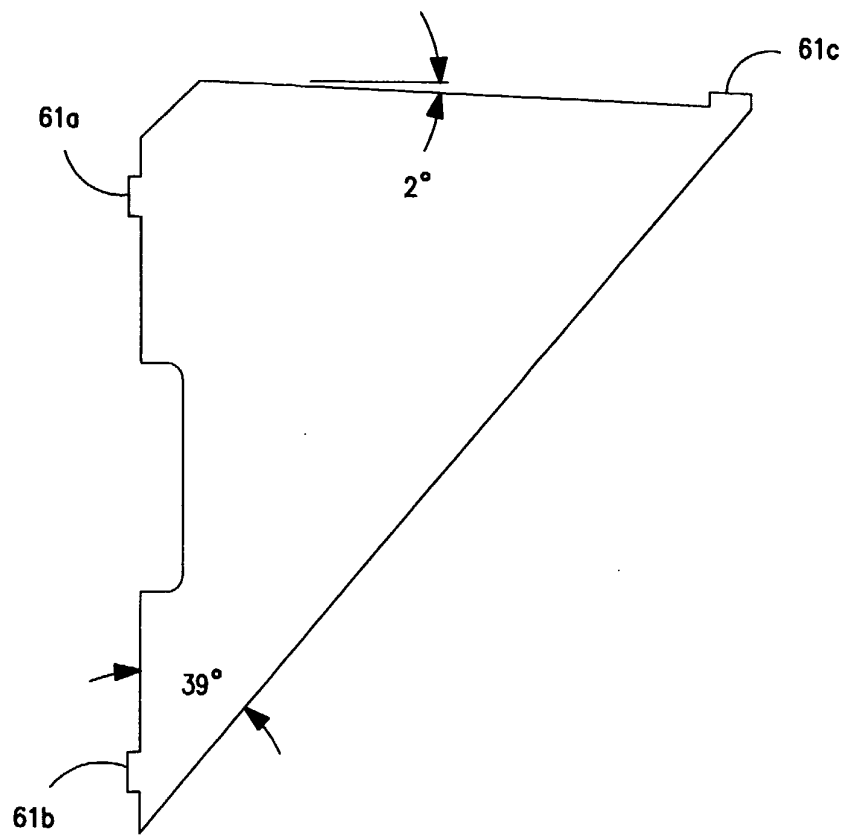
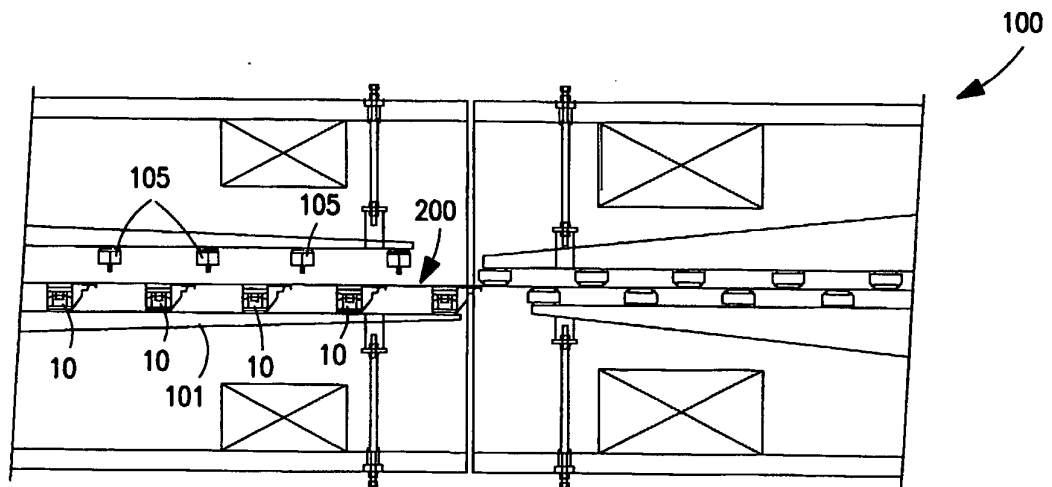

FIG. 6



**FIG. 7**



**FIG. 8**