

W. L. MORRIS.
 OILING DEVICE.
 APPLICATION FILED JUNE 19, 1903.

997,315.

Patented July 11, 1911.

Fig. I.

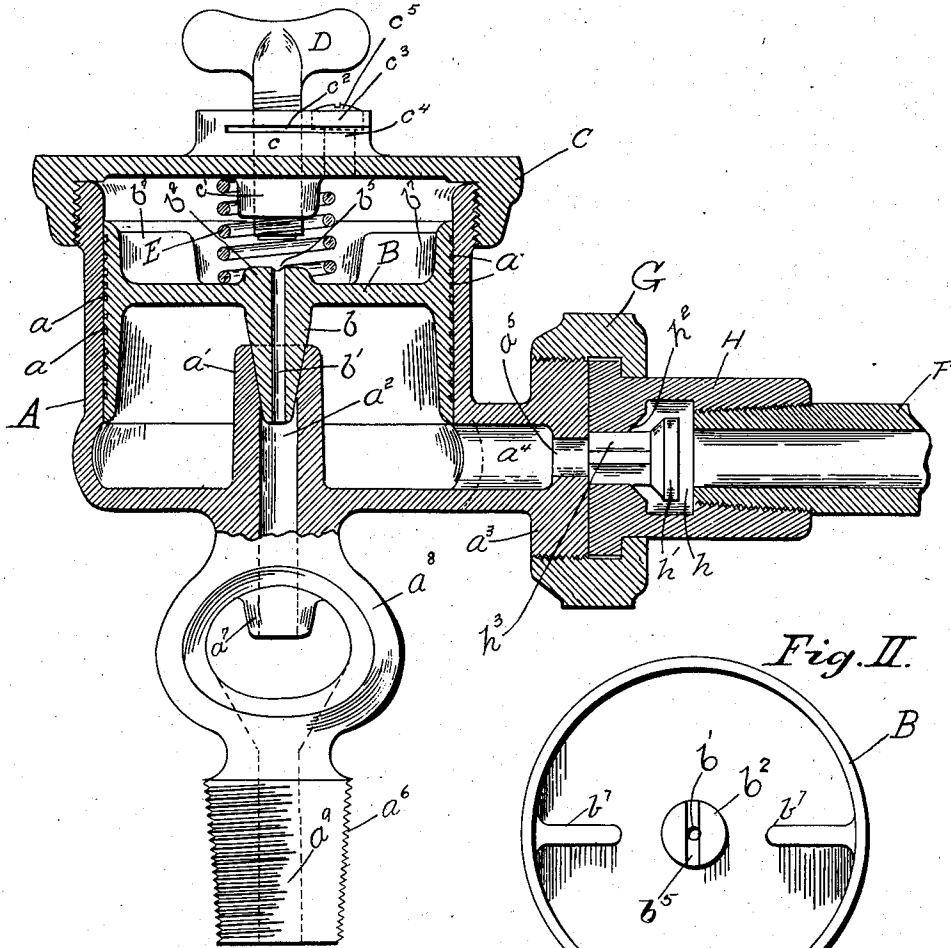

Fig. II.

WITNESSES:
G. T. Saywell
H. M. Potter

INVENTOR
Wm. L. Morris
 BY
J. O. Jay
 ATTORNEY

UNITED STATES PATENT OFFICE.

WILLIAM L. MORRIS, OF BATAVIA, ILLINOIS, ASSIGNOR TO S. F. BOWSER & COMPANY, INCORPORATED, OF FORT WAYNE, INDIANA, A CORPORATION OF INDIANA.

OILING DEVICE.

997,315.

Specification of Letters Patent. Patented July 11, 1911.

Application filed June 19, 1903. Serial No. 162,173.

To all whom it may concern:

Be it known that I, WILLIAM L. MORRIS, a citizen of the United States, resident of Batavia, county of Kane, and State of Illinois, have invented a new and useful Improvement in Oiling Devices, of which the following is a specification, the principle of the invention being herein explained and the best mode in which I have contemplated applying that principle, so as to distinguish it from other inventions.

My invention relates to oiling devices and principally to that class of devices in which oil is distributed by pressure to various points to which it is required to be conveyed.

The object of such an invention is to provide a device of said character, whereby such distribution may be economically and efficiently effected.

Said invention consists of the means hereinafter fully described and specifically set forth in the claims.

The annexed drawing and following description set forth in detail certain means for carrying out my invention, said disclosed means constituting but one of various forms in which the principle of my invention may be used.

In said annexed drawings:—Figure I represents a vertical cross sectional view of the device embodying my said invention, portions of such device being shown in side elevation. Fig. II represents a top plan view of a piston constituting part of said device.

The oil cup A is provided with a cylindrical bore in which slides the piston B. This piston is formed upon its outer surface with a series of parallel grooves a , as shown in Fig. I. The central portion of the piston is formed with an outwardly projecting portion which is conical in form, and forms a valve b . Coaxial with such valve is a bore b' which pierces the piston and forms a passage-way through the same by means of which oil may pass from one side of the piston to the other. Surrounding such bore is formed an upward projection b^2 upon

which is formed a transverse groove b^5 intersecting the bore b' . From the bottom of the oil cup and projecting upwardly is formed a projection a' having a centrally located bore a^2 coaxial with the bore b' . This bore a^2 serves as an outlet for the oil from the chamber of variable volume formed in the cup A by the face of the piston B and the walls of the cup, such chamber being in effect merely a passage-way connecting said oil outlet with the oil inlet described later. A portion of the bore a^2 is enlarged, conical in form and adapted to receive the valve b as shown in Fig. I.

The upper portion of the outer surface of the cup A is provided with external screw threads which receive the cap C forming a cover for the cup. The central portion of this cap is formed with two bosses c and c' , the boss c being located on the upper or outer surface of the cap, and the boss c' being formed upon and projecting from the lower surface thereof. These bosses and cap are formed with a centrally located threaded bore, coaxial with the bores b' and a^2 , into which is screwed the screw D provided with a suitable thumb piece upon its outer end, whereby it may be manually operated. This screw, it will be seen, may be caused to limit the upward stroke of the piston B by contact therewith, such contact not in any way closing the bore b' to communication with the upper portion of the oil cup, by reason of the presence of the transverse groove b^5 . The piston is maintained when out of service in its closed position with the valve b upon its seat in the bore a^2 , by means of a helical spring E bearing upon the upper surface of the piston and confined by the cap C, the boss c' and projection b^2 maintaining the central position thereof, as will be readily understood. Projecting laterally from the lower portion of the cup is a nipple a^3 formed with the bore a^4 communicating with the interior of the cup as is shown, and serving as an oil inlet to the chamber formed by the face of the piston B and the walls of the cup. This nipple is provided with external screw threads by

means of which the extremity of a pipe or duct F may be secured to the cup through the medium of coupling G. The end of the pipe F is threaded to receive a check valve holder H in the end of which is formed a valve chamber h in which is seated the check valve h' . This valve is located in a manner such that it may close the end opening h^2 of the valve chamber, which is in alignment with the end opening a^5 in the nipple a^3 , as the result of liquid under pressure within the pipe F, when the pipe is detached as will further appear. The valve guide h^3 is of a length such that when the pipe and valve holder are detached from the nipple a^3 , it projects from the end of said holder, when the valve h' is in its closing position. The opening a^5 in the nipple is made of a diameter smaller than that of the opening h^2 , so that it will be seen that when the nipple and valve holder are in juxtaposition, the check valve will be held to permit the opening h^2 to be normally open, and the passage of the oil permitted from the pipe into the nipple bores a^5 and a^4 and so into the aforementioned chamber in said cup which serves as a passage-way to the outlet a^2 .

The lower portion of the oil cup is formed with the threaded portion a^6 which may be attached to the mechanism to be oiled, and intermediately of such portion and the lower cup portion is formed a feed sight portion a^8 into which projects a nozzle a^7 pierced by the bore a^2 , which forms as before stated the outlet to cup A. Coaxial with the bore a^2 and through the threaded portion a^6 is formed a bore a^9 having an enlarged upper portion as shown in dotted lines in Fig. I.

The upper portion of the piston B is formed with two ears b^7 which may be utilized to remove the piston from the cup when such removal is required.

The boss c formed upon the upper portion of the cap C is formed with a transversely located slot c^2 which intersects the axis of the thread bore formed in the cap, as shown in Fig. I. This slot effects a formation of a movable piece c^3 having one free end and the other fixed, as will be readily understood. A screw seat is formed in said piece c^3 as shown in the dotted lines in Fig. I, in which is seated the screw c^5 which has threaded engagement with the lower portion of said piece as shown in dotted outline at c^4 . It will hence be seen that by setting the screw c^5 the movable portion c^3 may be caused to jam upon the threads of said screw D and thereby fix the same securely in position. The parts being in their normal position, shown in Fig. I, with the screw D adjusted so as to allow the required opening

of the outlet a^2 and with the piston in its customary lower position, that is, not in contact with the lower end of the screw D, it will be seen that communication between the outlet a^2 and supply pipe F is cut off. The oil now being forced through the pipe under pressure, passes through the open check valve h' , through inlet a^2 , into the chamber in cup A formed by the face of the piston B and the walls of the cup and raises the piston B, so as to remove the valve from its seat, thereby permitting the oil to flow through the outlet a^2 and so reach the bearing to be oiled through the medium of the bore a^9 . Upon removal of such pressure the piston and valve are returned to their normal positions by the action of the spring E. The grooves a are formed for the purpose of offering obstruction to the passage of oil between the contiguous surfaces of the piston and oil cup. It is not necessary to cause the piston to fit the cup so as to be oil tight, and a slight leakage between said surfaces is not objectionable so long as such leakage does not exceed the least quantity of oil required for the bearing. The oil so passing or leaking into the upper portion of the cup passes through the bore b^7 and so to the bearing.

When it is desired for any reason to detach the supply pipe F, the coupling G is removed, thereby permitting the detachment of the ends of the pipe F and nipple a^3 . Immediately upon the recession of the pipe F, nipple a^3 and valve carrier H, the pressure of the oil within the pipe will force the valve h' upon its seat, thereby closing the end of the pipe and so preventing the leakage or discharge of oil therefrom. The oil under pressure is admitted into the pipe F by means of a suitable cock or valve whenever it is required. The tension of the spring E is made such that it will overcome the resistance of oil in the cup, when said cock or valve is closed and the pressure so removed, the valve-opening into the top of the projection a^7 being so closed by valve b .

Other modes of applying the principle of my invention may be employed instead of the one explained, change being made as regards the mechanism herein disclosed provided the means stated by any one of the following claims or the equivalent of such stated means be employed.

I therefore particularly point out and distinctly claim as my invention—

1. In an oiling device, the combination with an oil cup having an oil inlet and an oil outlet, of a piston fitting in said cup and adapted to control said oil outlet, said piston being operated by the pressure of the oil in said cup and being provided with a passage-way affording communication between

the upper face of said piston and said oil outlet.

2. In an oiling device, the combination with an oil cup having an oil inlet and an oil outlet, of a piston fitting in said cup and adapted to normally close said oil outlet and to be actuated by the pressure of the oil in said cup to open said oil outlet, said piston being provided with a passage-way affording uninterrupted communication between said piston's upper face and said oil outlet.

3. In an oiling device, the combination with an oil-cup, of a piston fitting in said cup and forming a chamber therein, said cup being provided with an oil inlet and an oil outlet opening into such chamber, and said piston being provided on one side with a projection adapted to close said outlet and with a passage-way connecting said outlet with its other side.

4. In an oiling device, the combination with a closed oil cup, of a piston fitting in said cup and dividing it into two chambers, said cup being provided with an oil inlet and an oil outlet opening into one of said chambers, and said piston being provided with a projection adapted to close said outlet to said last named chamber and with a passage-way always open connecting said outlet with said other chamber.

5. In an oiling device, the combination of an oil cup provided with an oil outlet, a piston provided with a valve on one side thereof for controlling said outlet, an oil inlet in said cup, said piston forming with the cup a chamber of variable volume and operating to unseat said valve when said chamber is enlarged by the movement of the piston, and a passageway for the oil leading from the oil cup on the side of the piston opposite to the side on which the valve is located, to the said outlet.

6. In an oiling device, the combination with an oil cup having an oil inlet and an oil outlet, of a piston fitting said cup and adapted to control said oil outlet, and means tending normally to move the piston in a direction to close the outlet, said piston being operated in the opposite direction against the tension of the said means to open the outlet by the pressure of the oil in said cup, said piston being provided with a passageway affording communication between the upper face of said piston and said oil outlet.

7. In an oiling device, the combination with an oil cup having an oil inlet and an oil outlet, of a piston fitting said cup and adapted to control said oil outlet, means tending normally to move the piston in a direction to close the outlet, said piston being operated in the opposite direction

against the tension of the said means to open the outlet by the pressure of the oil in said cup, said piston being provided with a passageway affording communication between the upper face of said piston and said oil outlet, and means independent of said oil pressure for controlling the extent of operation of the piston.

8. In an oiling device, the combination with an oil cup having an oil inlet and an oil outlet, of a piston fitting said cup and adapted to control said oil outlet, means tending normally to move the piston in a direction to close the outlet, said piston being operated in the opposite direction against the tension of the said means to open the outlet by the pressure of the oil in said cup, said piston being provided with a passageway affording communication between the upper face of the said piston and said oil outlet, and an adjustable stop for controlling the extent of operation of the piston by the oil pressure.

9. In an oiling device, the combination with an oil cup having an oil inlet and an oil outlet, of a piston fitting said cup and adapted to control said oil outlet, and means tending normally to move the piston in a direction to close the outlet, said piston being operated in the opposite direction against the tension of the said means to open the outlet by the pressure of the oil in said cup, said piston being provided with a passageway affording communication between the upper face of the said piston and said oil outlet.

10. In an oiling device, the combination with an oil cup having an oil inlet and an oil outlet, of a piston fitting said cup and adapted to control said oil outlet, and mechanical means tending normally to move the piston in a direction to close the outlet, said piston being operated in the opposite direction against the tension of the said means to open the outlet by the pressure of the oil in said cup, said piston being provided with a passageway affording communication between the upper face of the said piston and said oil outlet.

11. In an oiling device, the combination of an oil cup, a piston movable therein, said cup being provided with an oil inlet and an oil outlet on the same side of the piston, a valve operatively related to the piston for controlling the outlet, the face of the piston opposite to the face adjacent which the valve is located being recessed and provided with one or more projecting lips located within the recess by means of which the piston may be lifted from the oil cup, said piston being provided with a passageway leading from the face thereof opposite to the face which is adjacent the outlet, said

passageway having communication with the outlet, and a removable cap for the oil cup.

12. In an oiling device, a cylinder, a piston operating in said cylinder, said cylinder having an oil inlet and oil outlet on the same side of the piston, a valve operatively connected to the piston for actuation thereby, the area of the piston being greater than the area of the oil outlet, and means acting upon the piston and forming a resistance

thereto, said piston being adapted to be actuated by the pressure of the oil to open the valve when the pressure of the oil on the piston is greater than the said resistance.

Signed by me, this 21st day of May, 1903. 15

WILLIAM L. MORRIS.

Attested by—

L. M. DAVIS,
F. P. CONDE.