



US 20180168714A9

(19) **United States**  
(12) **Patent Application Publication**  
**Wiener et al.**

(10) **Pub. No.: US 2018/0168714 A9**  
(48) **Pub. Date: Jun. 21, 2018**  
**CORRECTED PUBLICATION**

(54) **SURGICAL GENERATOR FOR ULTRASONIC AND ELECTROSURGICAL DEVICES**

(71) Applicant: **Ethicon Endo-Surgery, Inc.**, Cincinnati, OH (US)

(72) Inventors: **Eitan T. Wiener**, Cincinnati, OH (US); **Jeffrey L. Aldridge**, Lebanon, OH (US); **Brian T. Noyes**, Mason, OH (US); **Jeffrey D. Messerly**, Cincinnati, OH (US); **James R. Giordano**, Milford, OH (US); **Robert J. Beetel, III**, Redwood City, CA (US); **Nathan J. Price**, Dunlap, IL (US); **Matthew C. Miller**, Cincinnati, OH (US); **Jeffrey P. Wiley**, Milford, OH (US); **Daniel W. Price**, Loveland, OH (US); **Robert L. Koch**, Cincinnati, OH (US); **Joseph A. Brotz**, Oshkosh, WI (US); **John E. Hein**, Neenah, WI (US)

(21) Appl. No.: **14/657,850**

(22) Filed: **Mar. 13, 2015**

**Prior Publication Data**

(15) Correction of US 2015/0182276 A1 Jul. 2, 2015  
See (63) Related U.S. Application Data.

(65) US 2015/0182276 A1 Jul. 2, 2015

**Related U.S. Application Data**

(63) Continuation of application No. 13/448,175, filed on Apr. 16, 2012, now Pat. No. 9,168,054, which is a continuation-in-part of application No. 13/251,766, filed on Oct. 3, 2011, which is a continuation-in-part of application No. 12/896,360, filed on Oct. 1, 2010, now Pat. No. 9,060,775.

(60) Provisional application No. 61/250,217, filed on Oct. 9, 2009.

**Publication Classification**

(51) **Int. Cl.**  
*A61B 18/12* (2006.01)  
*A61B 17/32* (2006.01)  
(52) **U.S. Cl.**  
CPC *A61B 18/1206* (2013.01); *A61B 2018/00767* (2013.01); *A61B 17/320068* (2013.01)

(57) **ABSTRACT**

A method for determining motional branch current in an ultrasonic transducer of an ultrasonic surgical device over multiple frequencies of a transducer drive signal. The method may comprise, at each of a plurality of frequencies of the transducer drive signal, oversampling a current and voltage of the transducer drive signal, receiving, by a processor, the current and voltage samples, and determining, by the processor, the motional branch current based on the current and voltage samples, a static capacitance of the ultrasonic transducer and the frequency of the transducer drive signal.

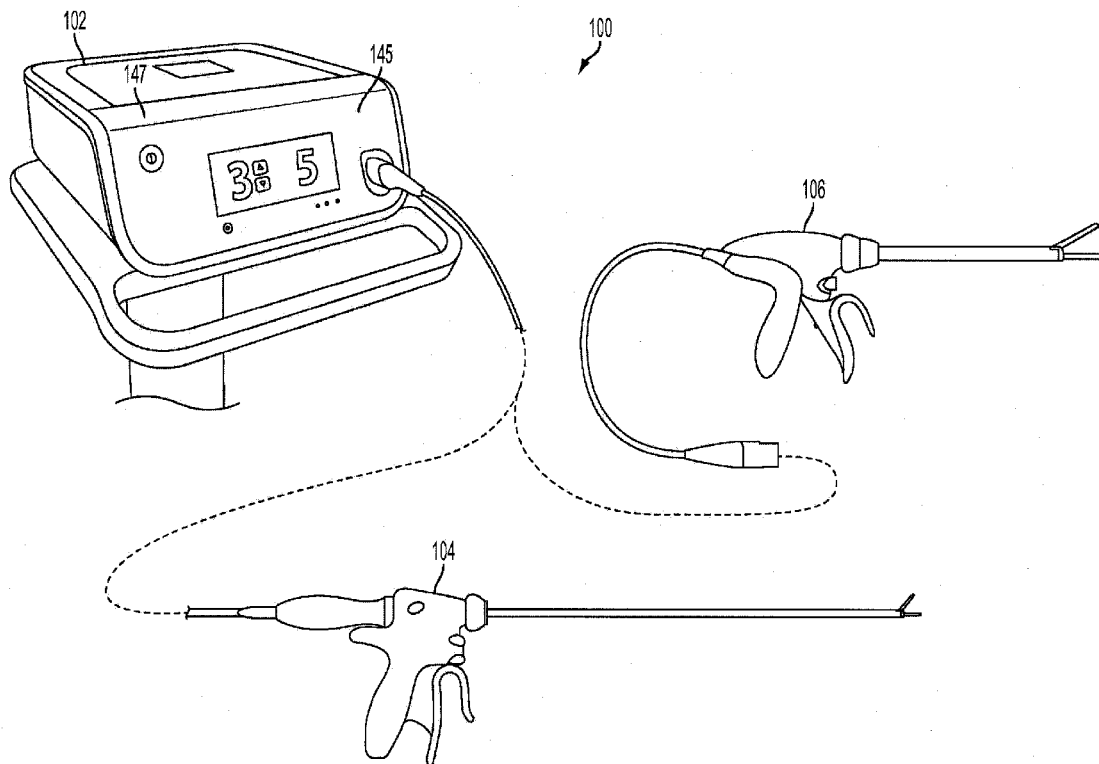

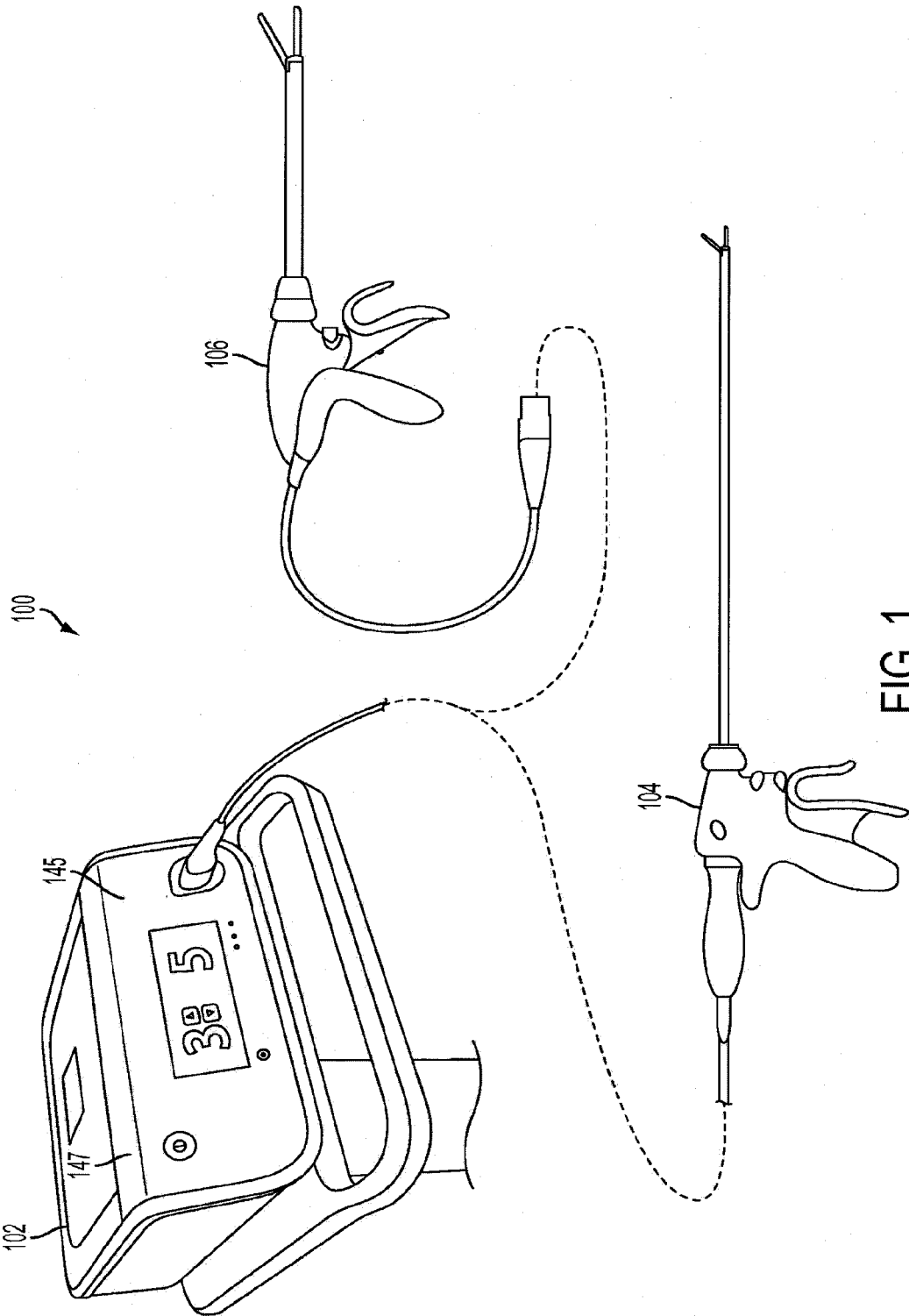
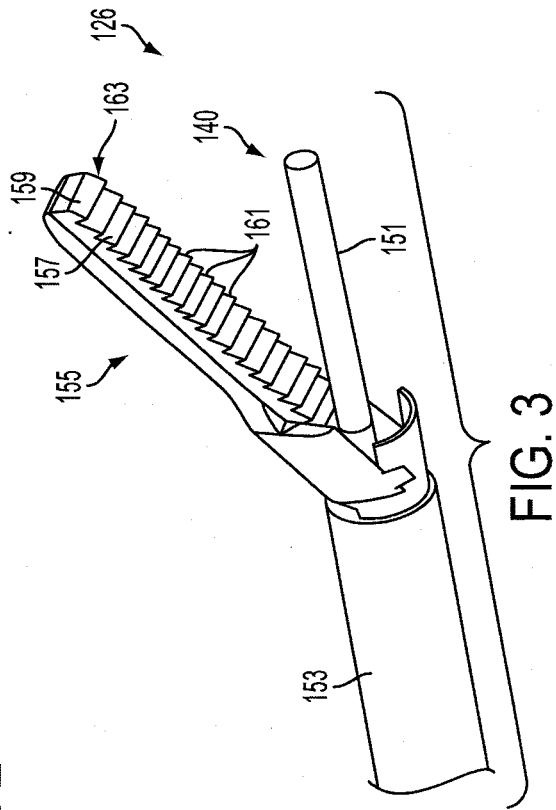
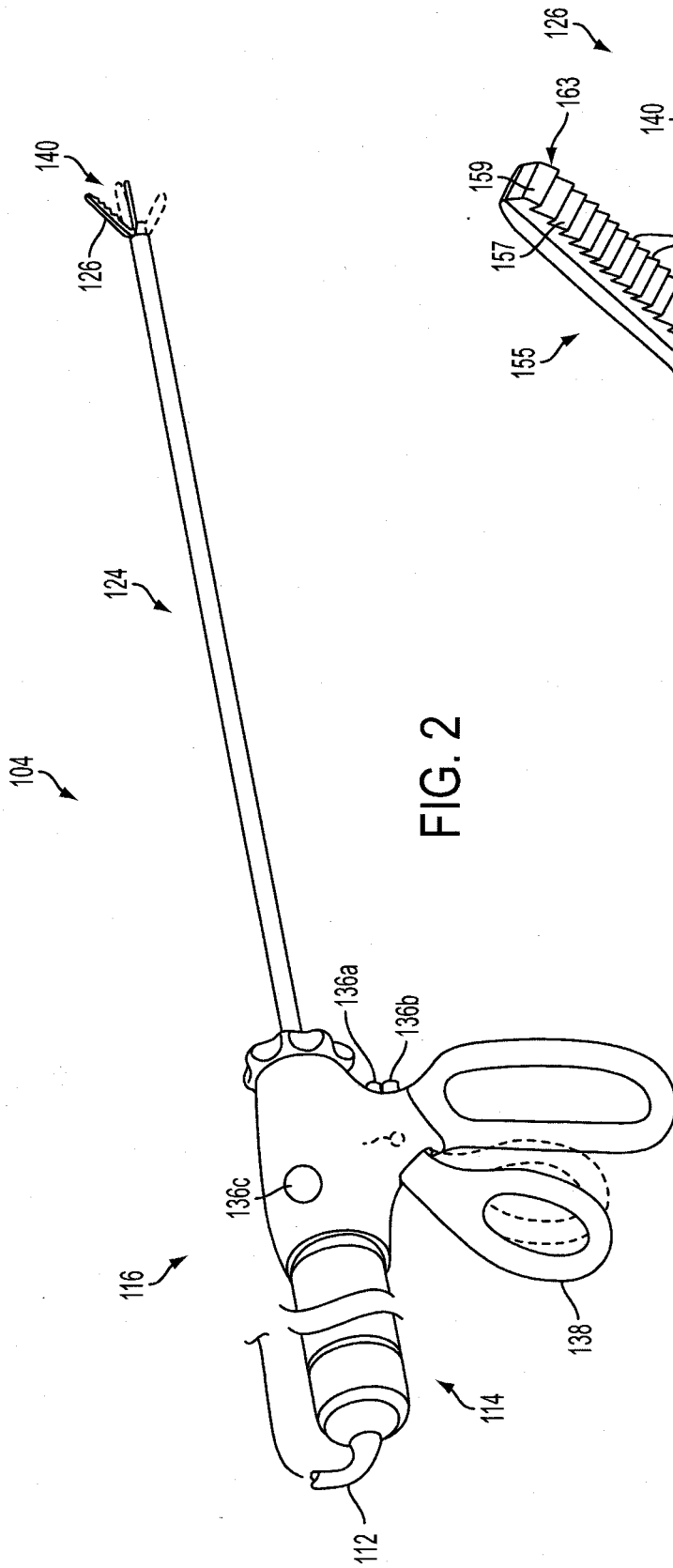
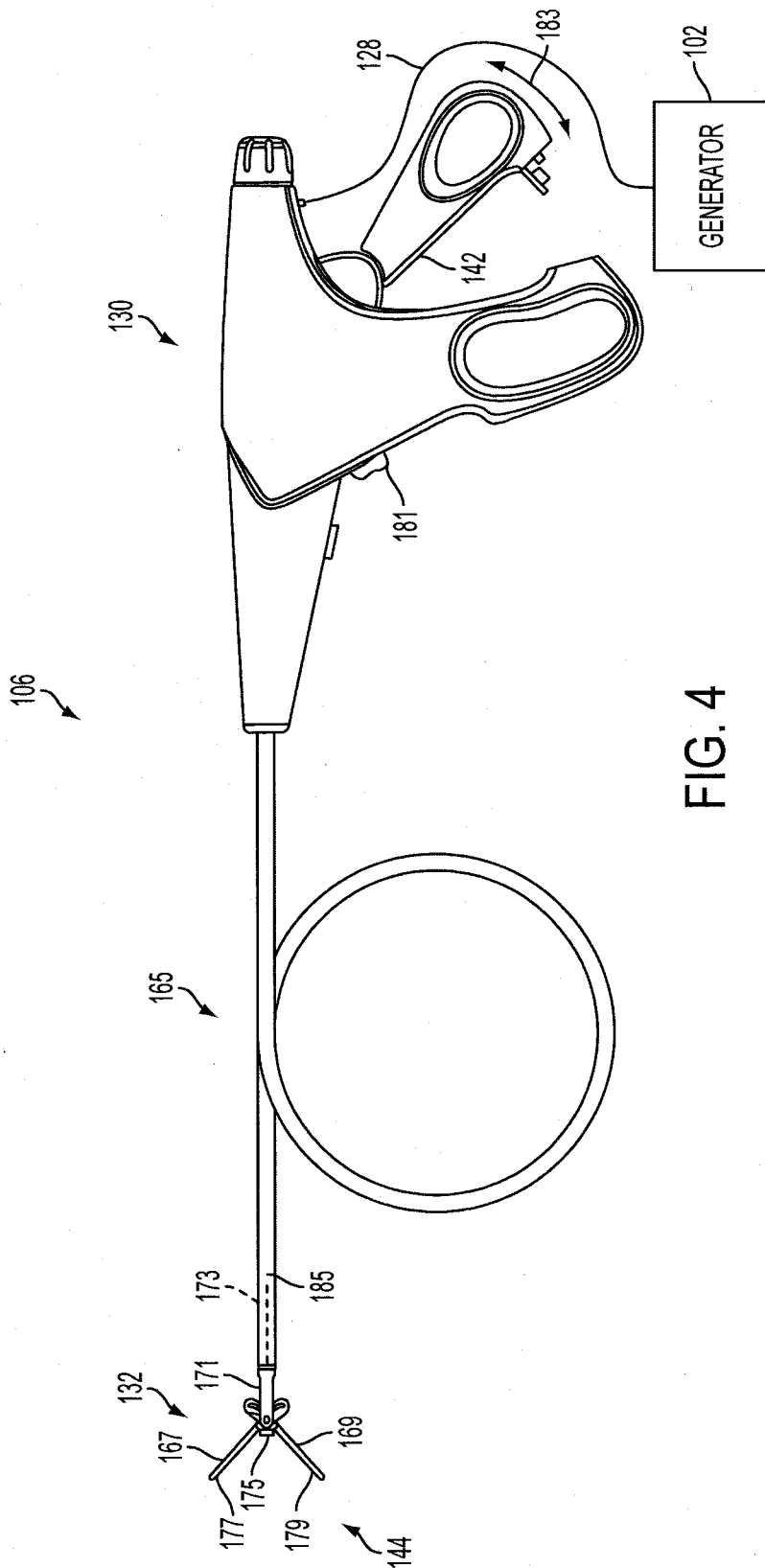

FIG. 1





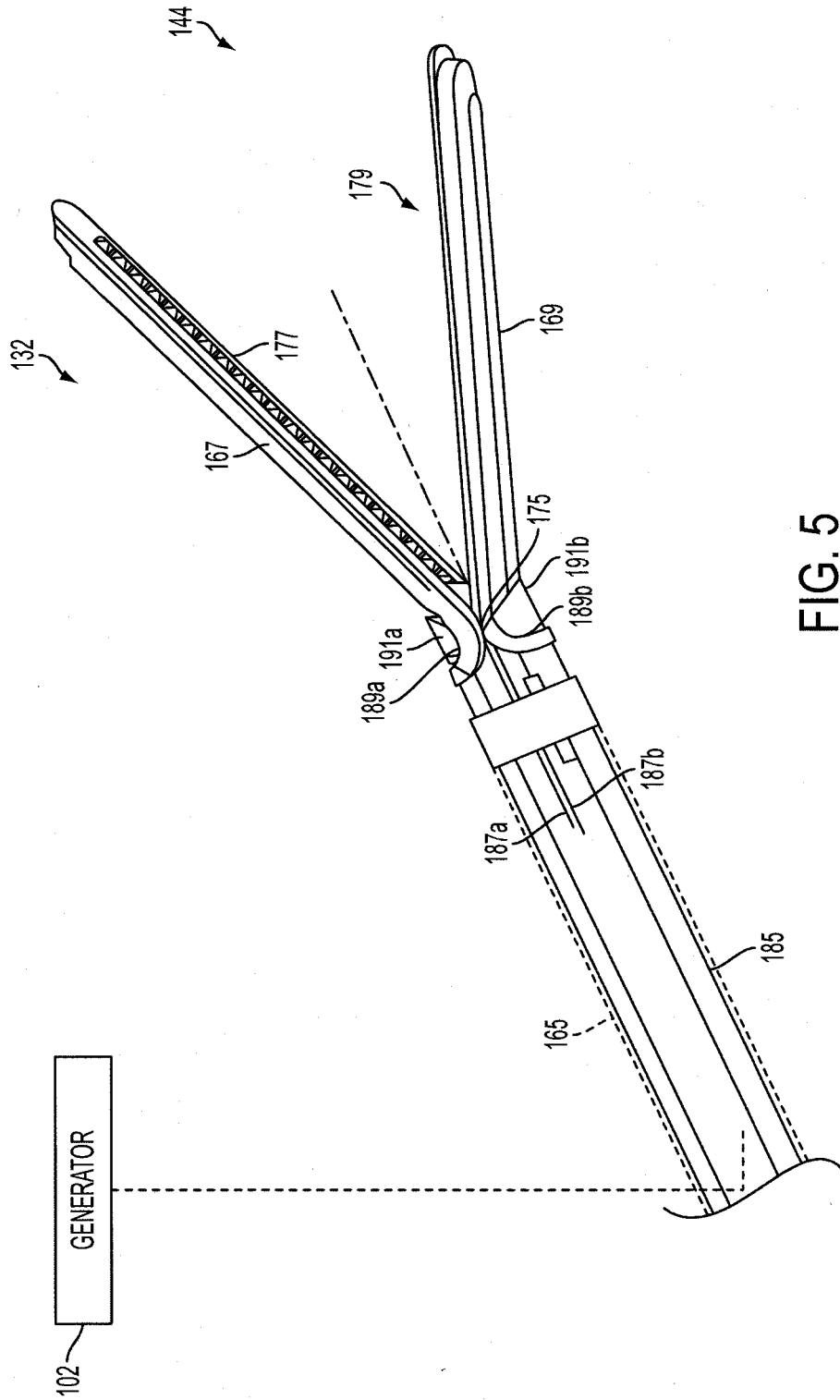

FIG. 5

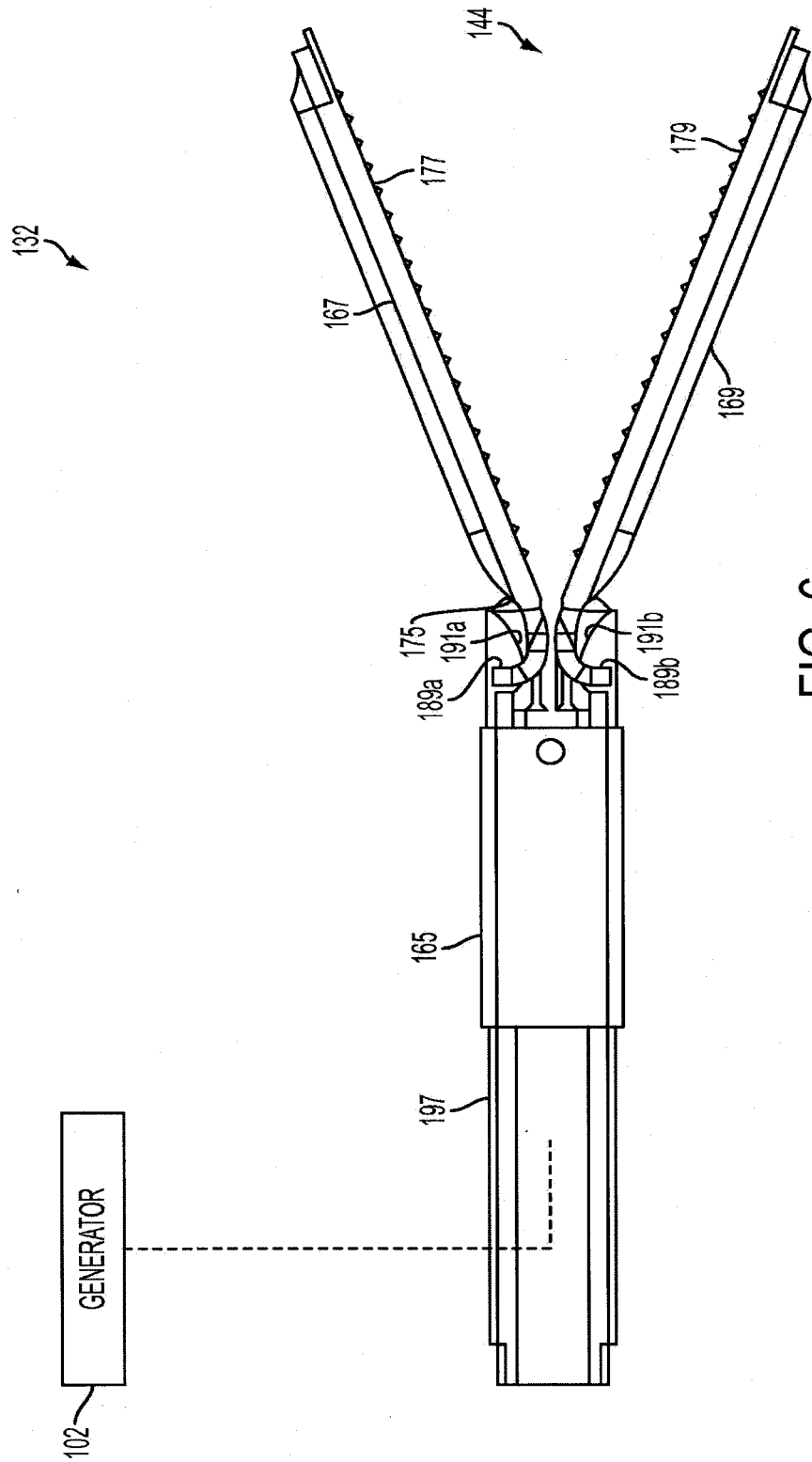

FIG. 6

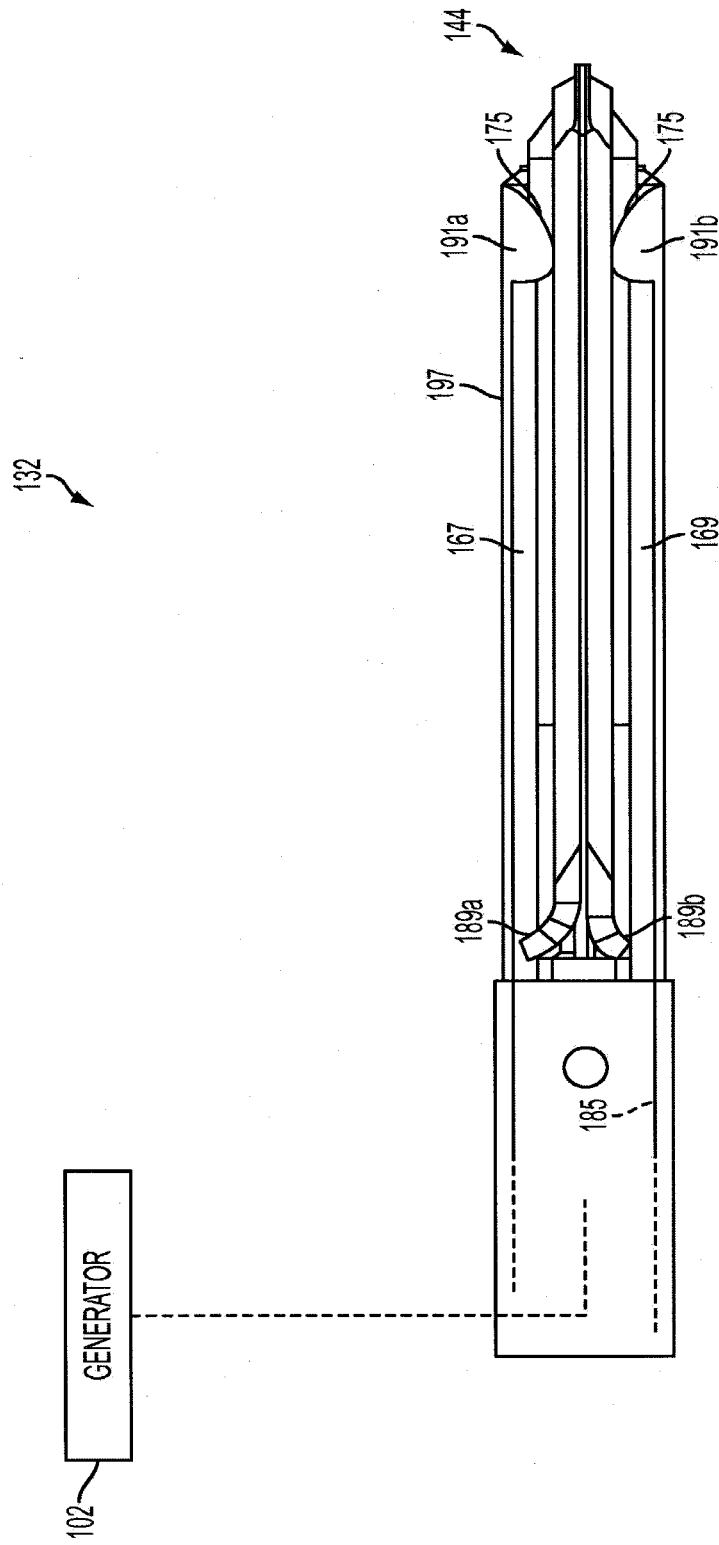

FIG. 7

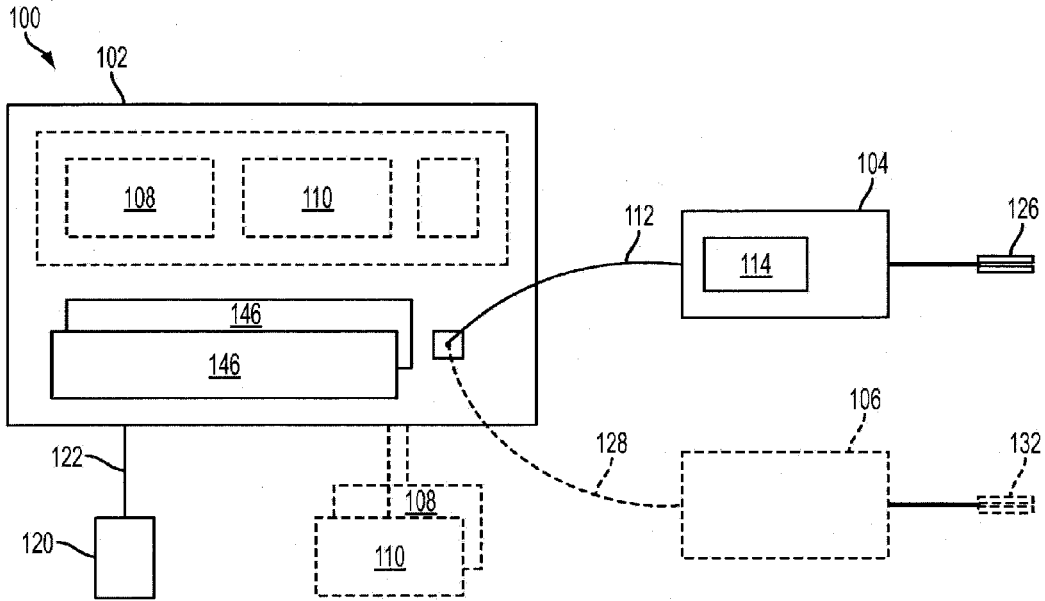

FIG. 8

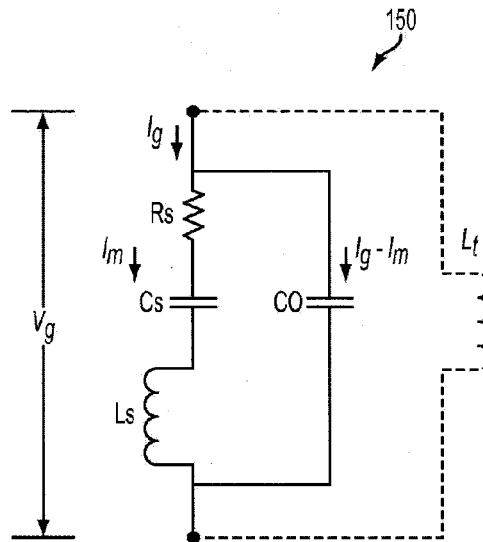

FIG. 9



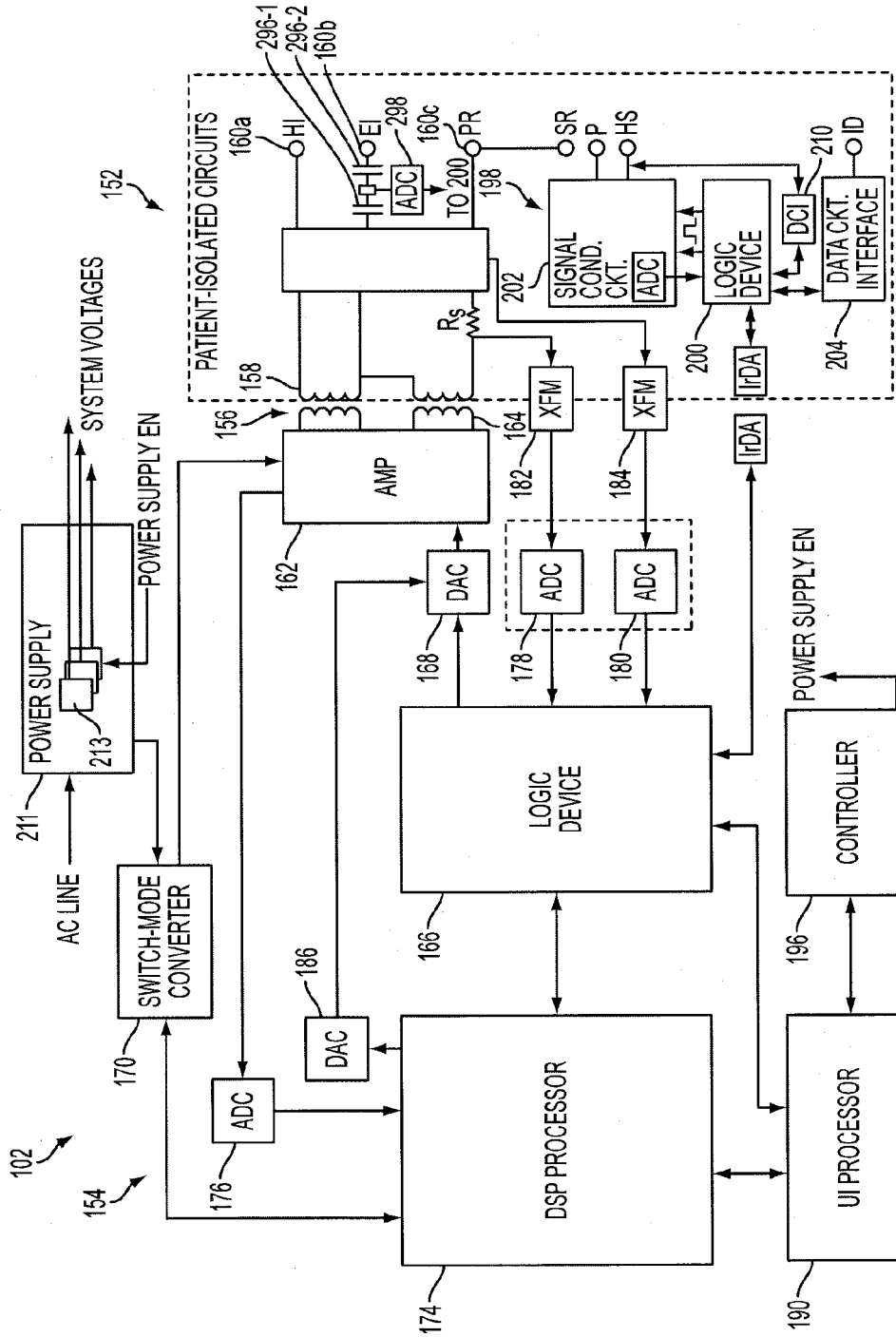

FIG. 10



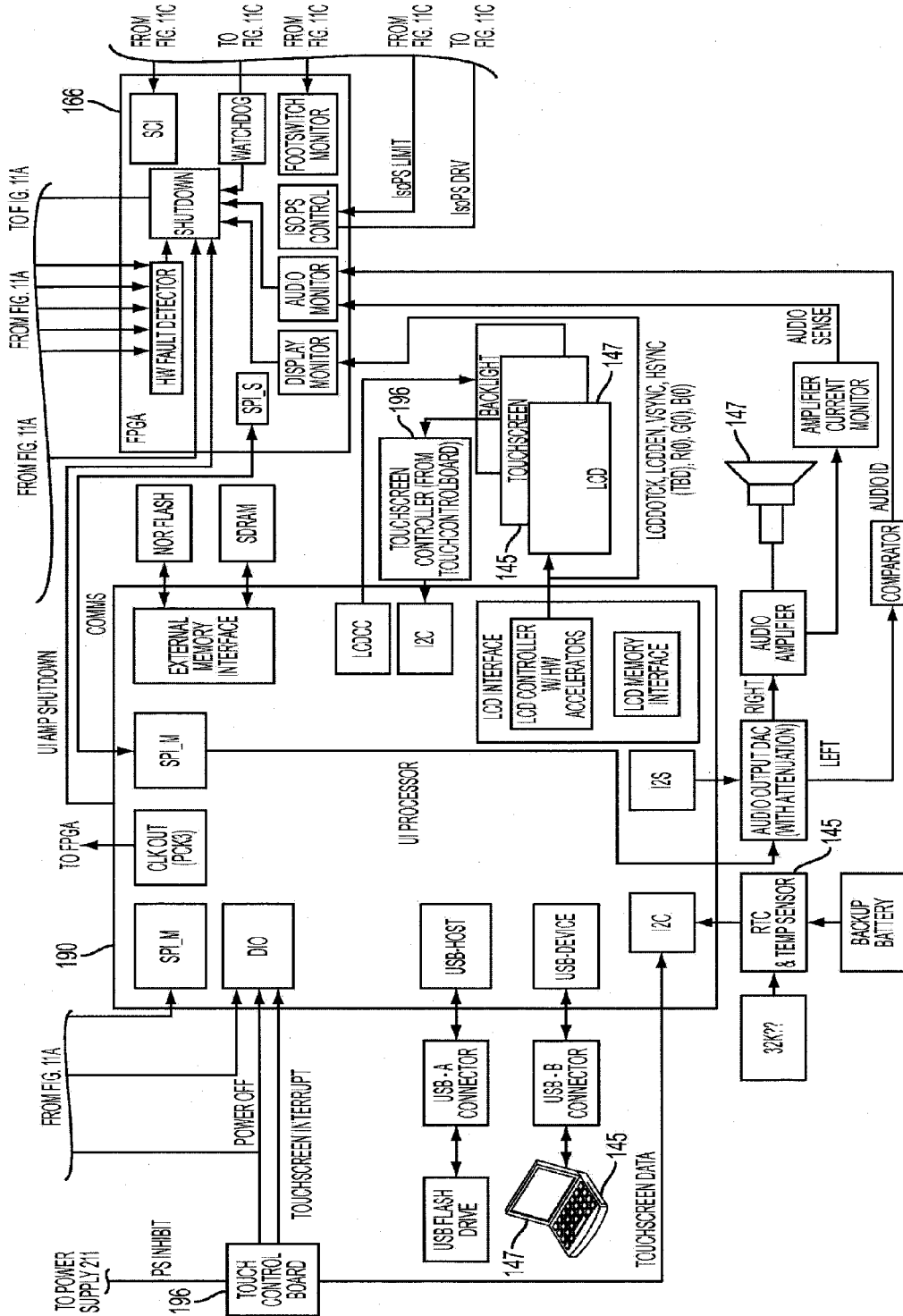

FIG. 11B

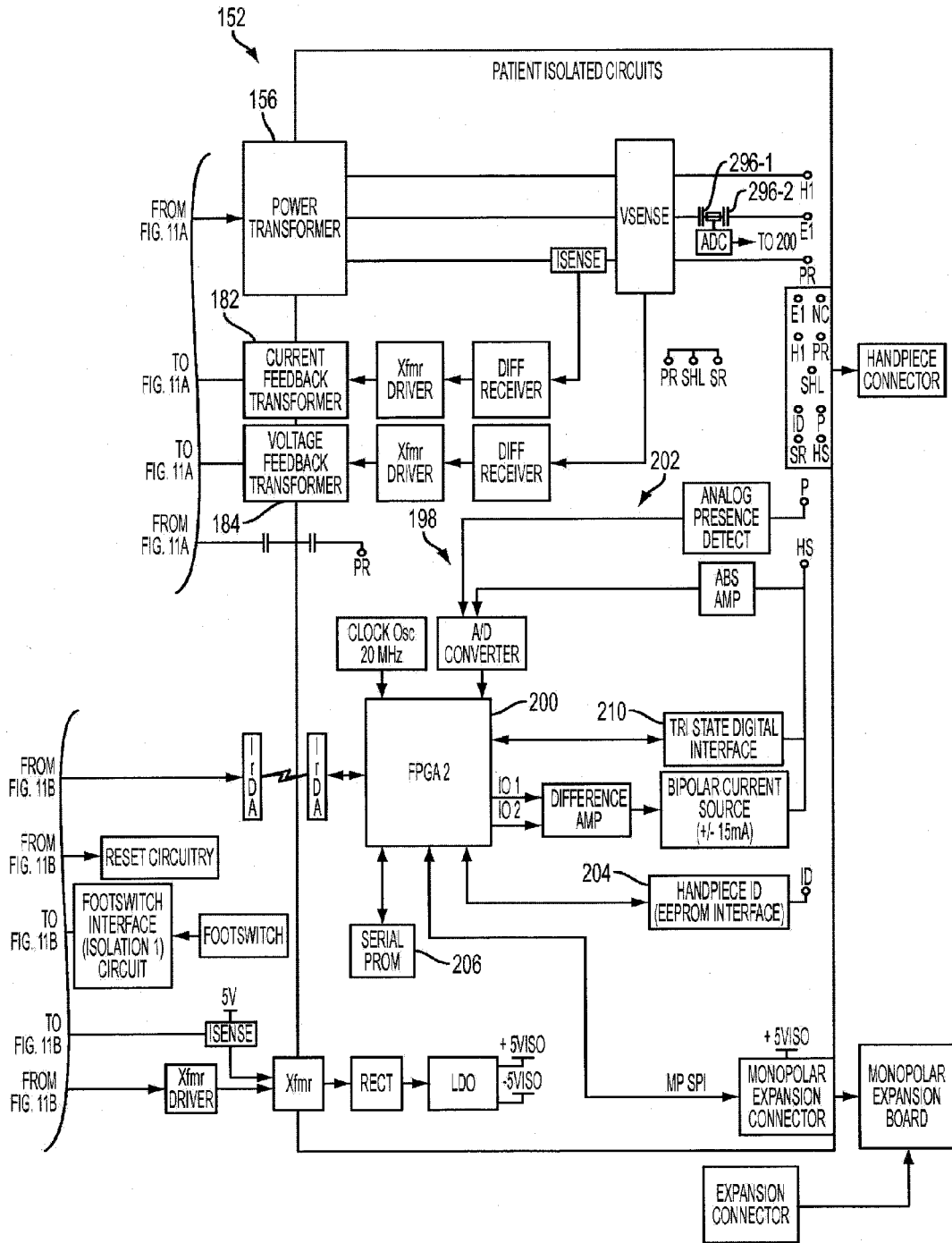

FIG. 11C

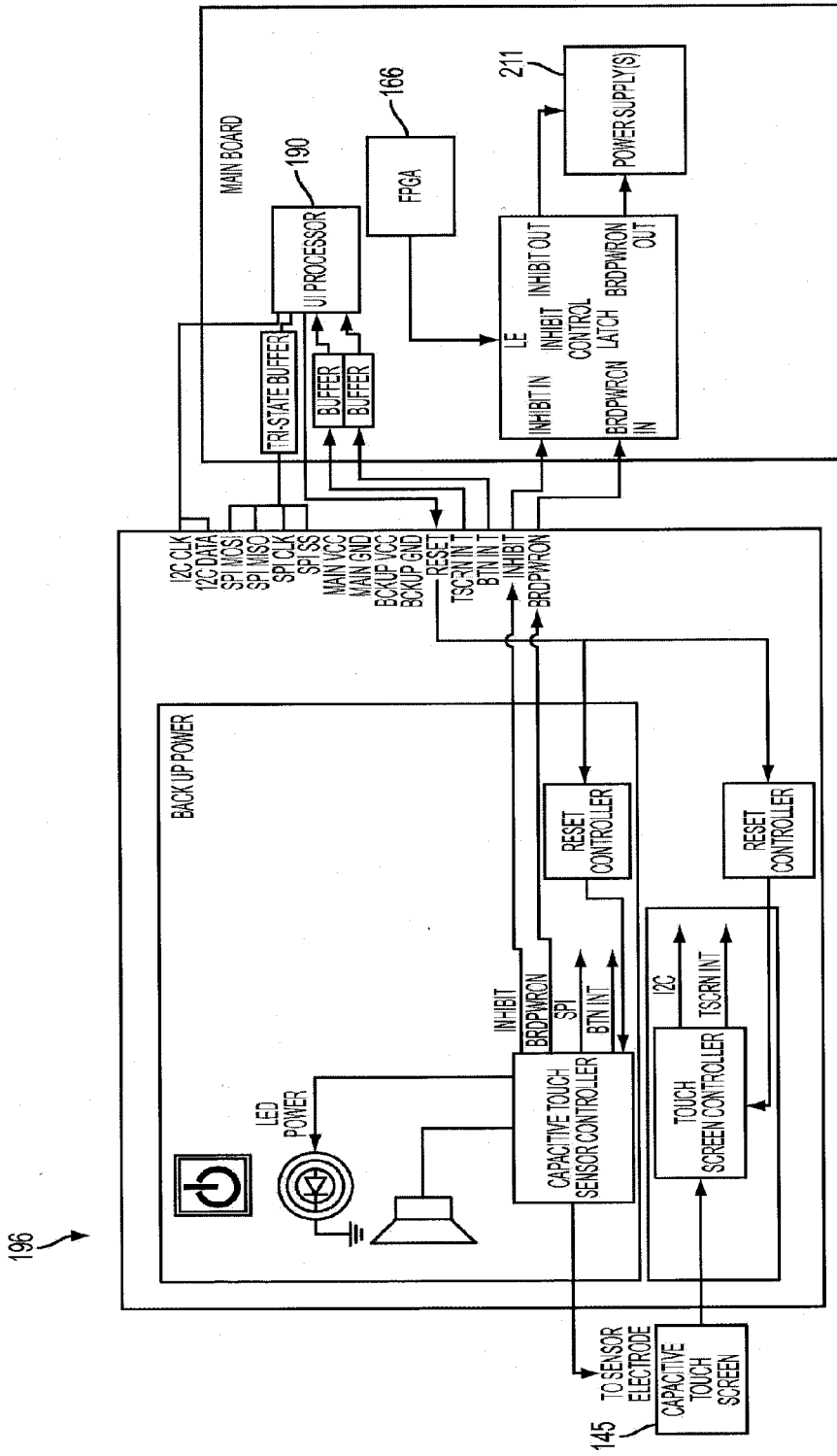

FIG. 12

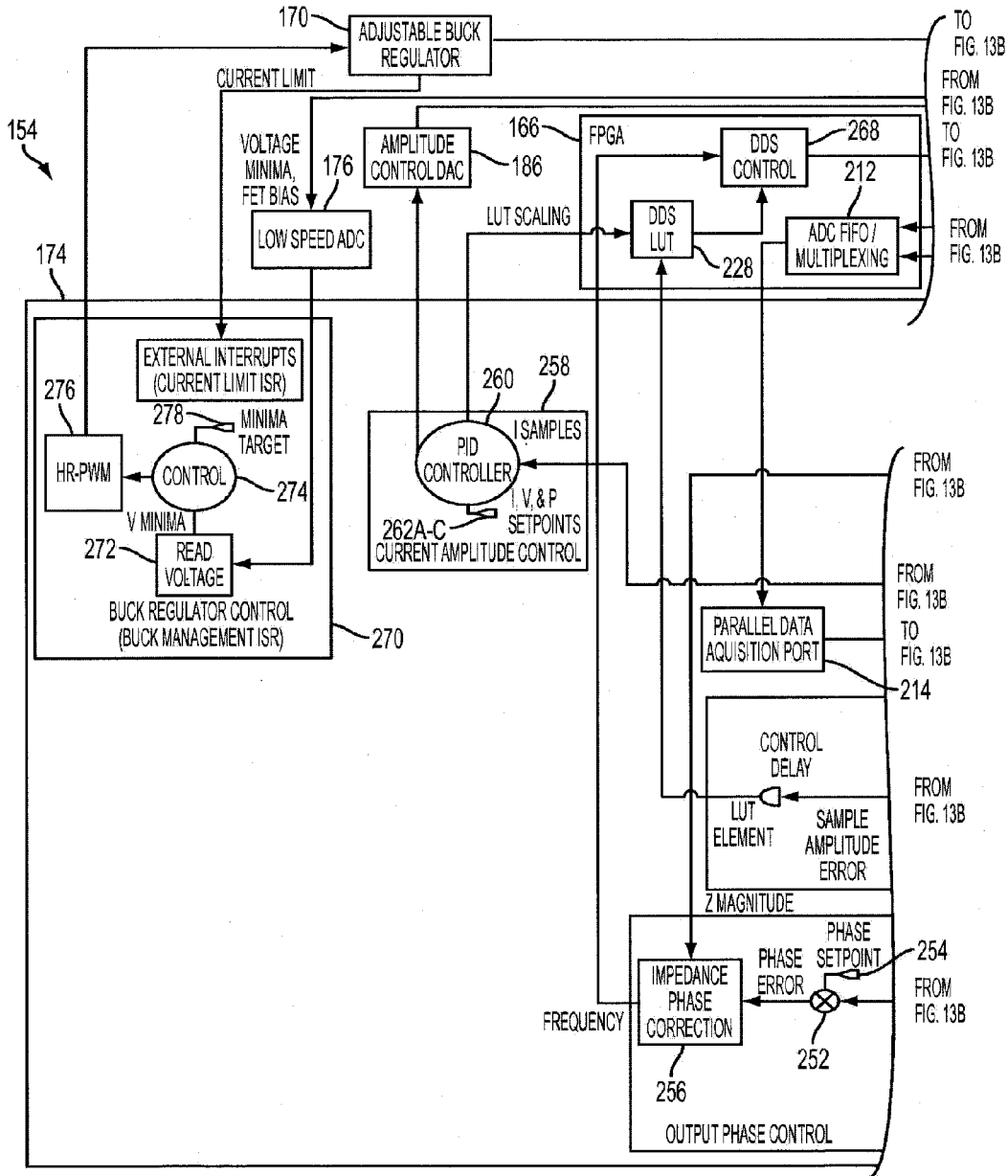

FIG. 13A

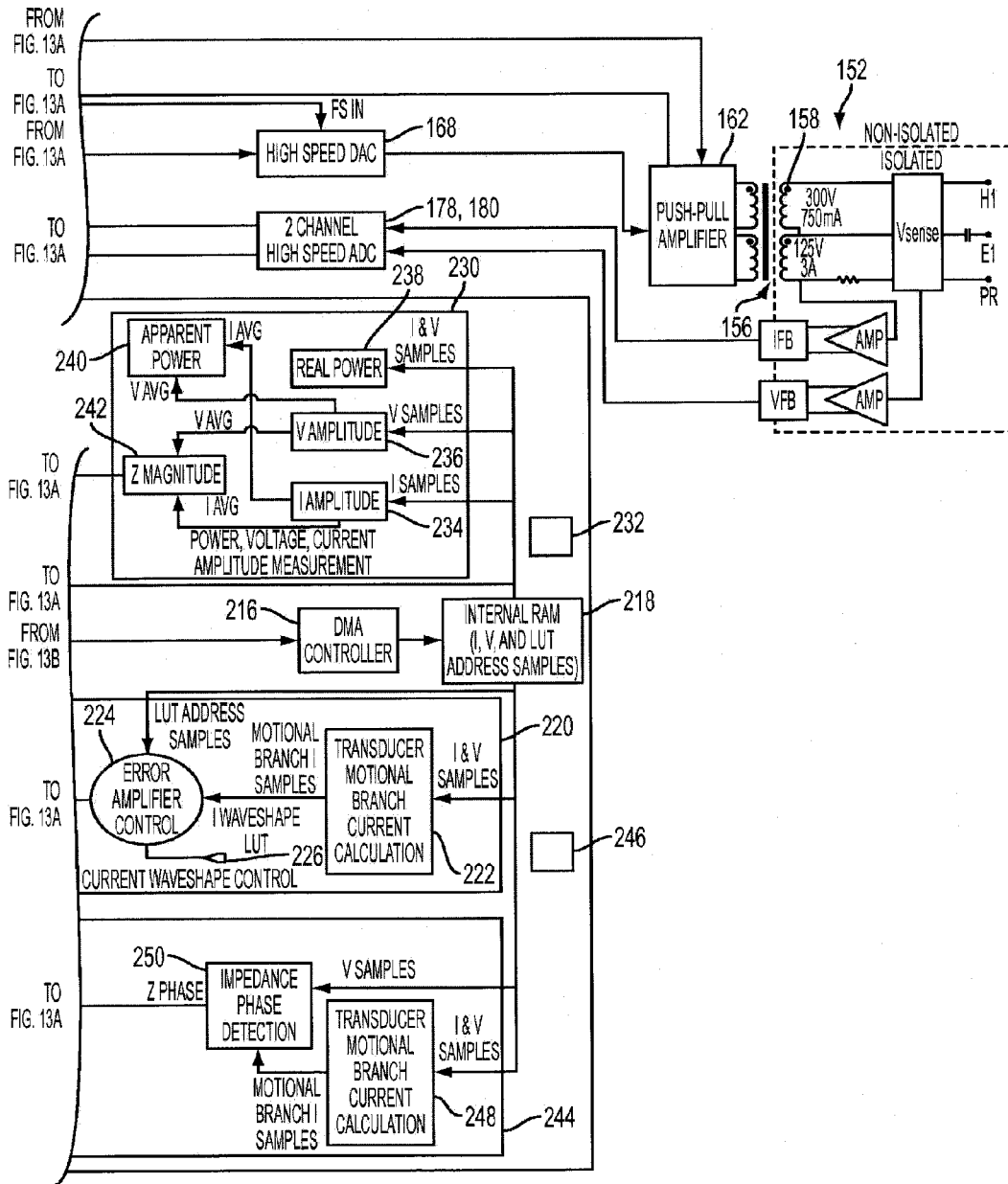

FIG. 13B

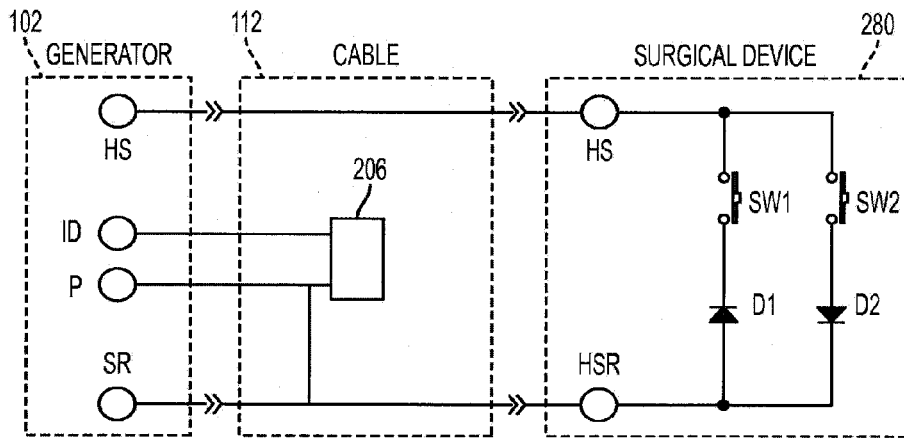

FIG. 14

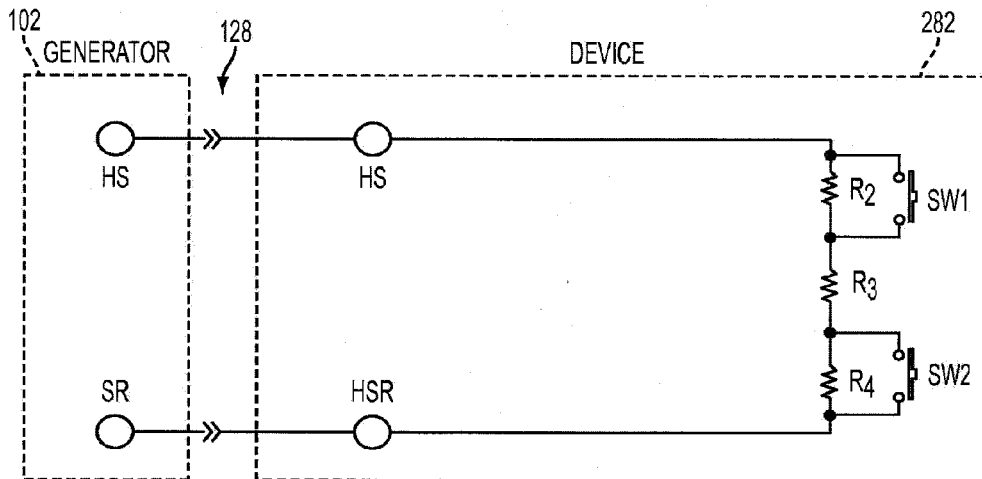
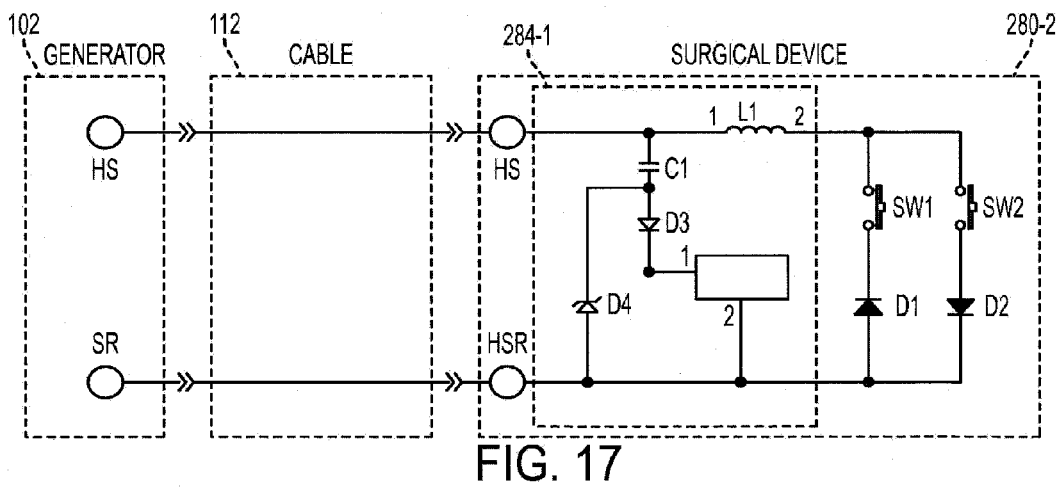
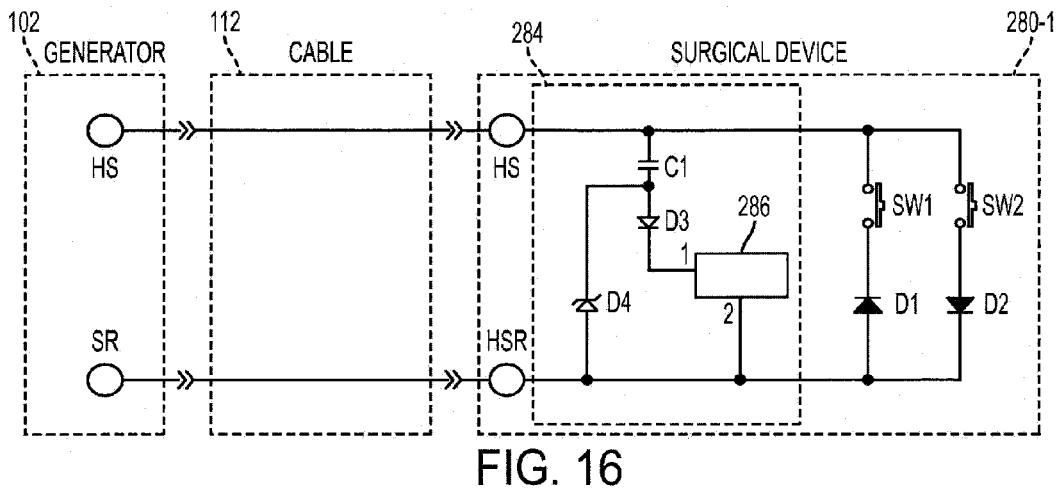

FIG. 15





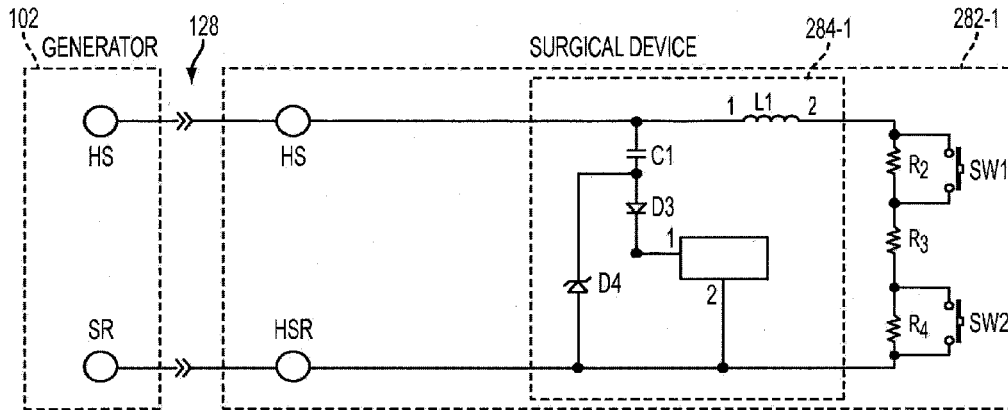

FIG. 18

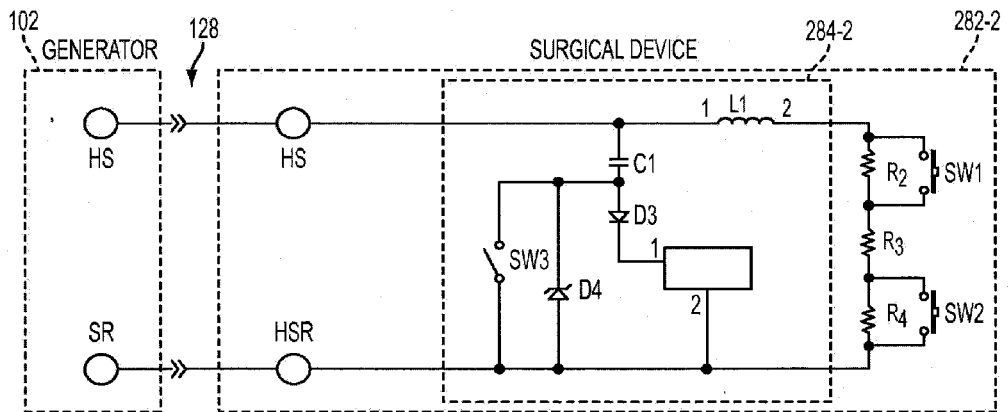
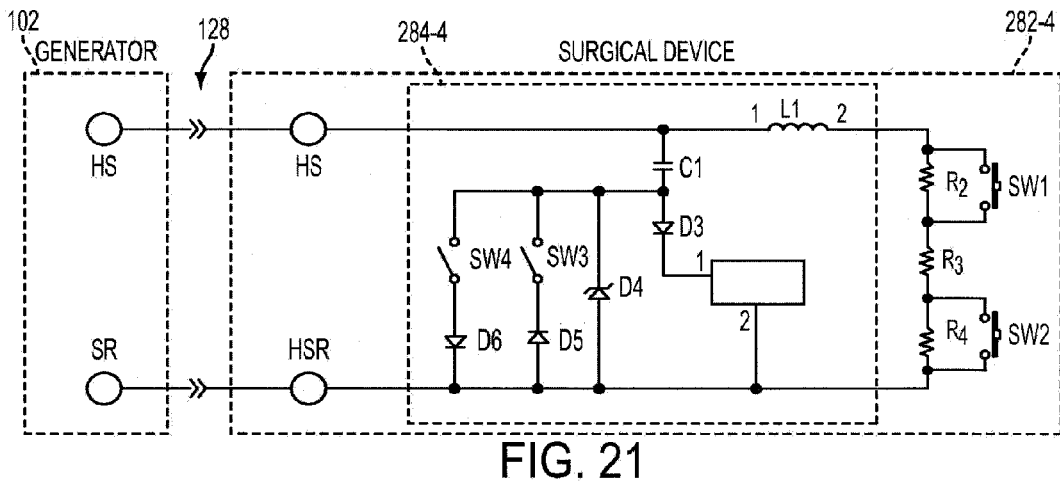
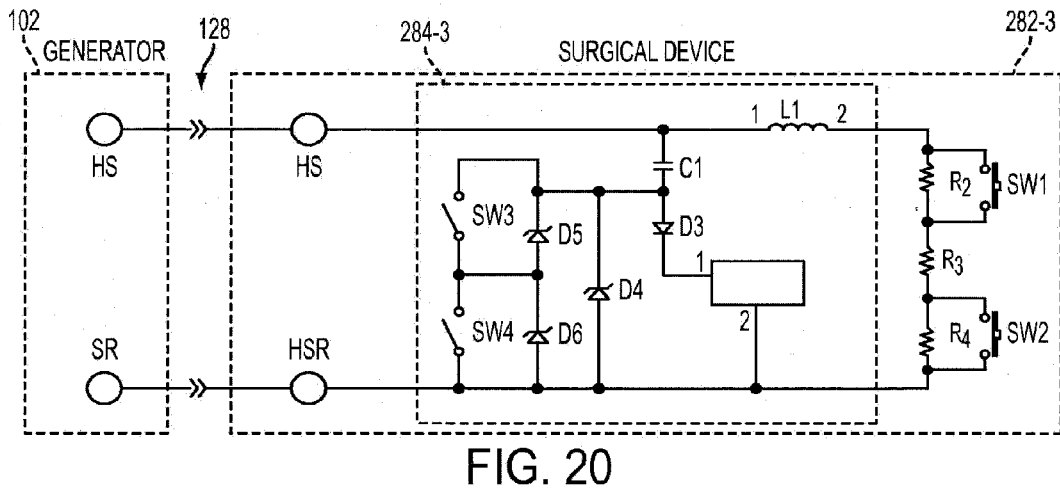

FIG. 19



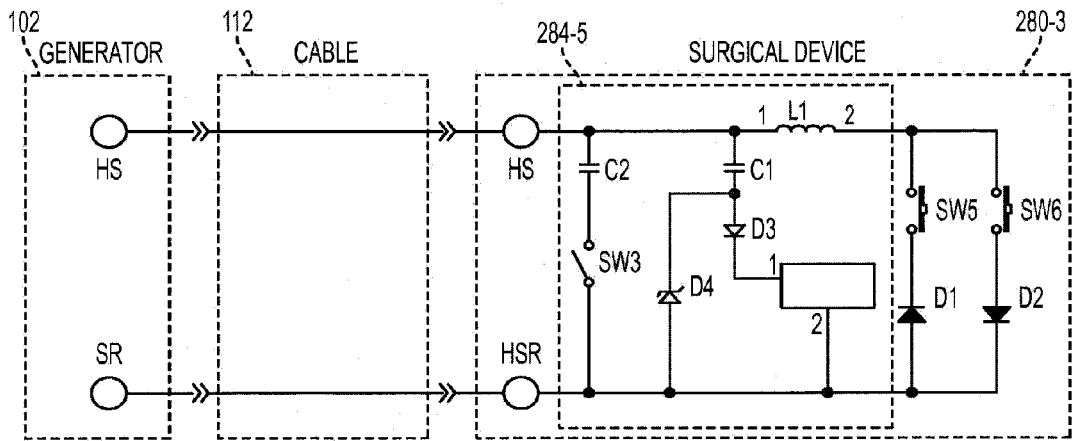

FIG. 22

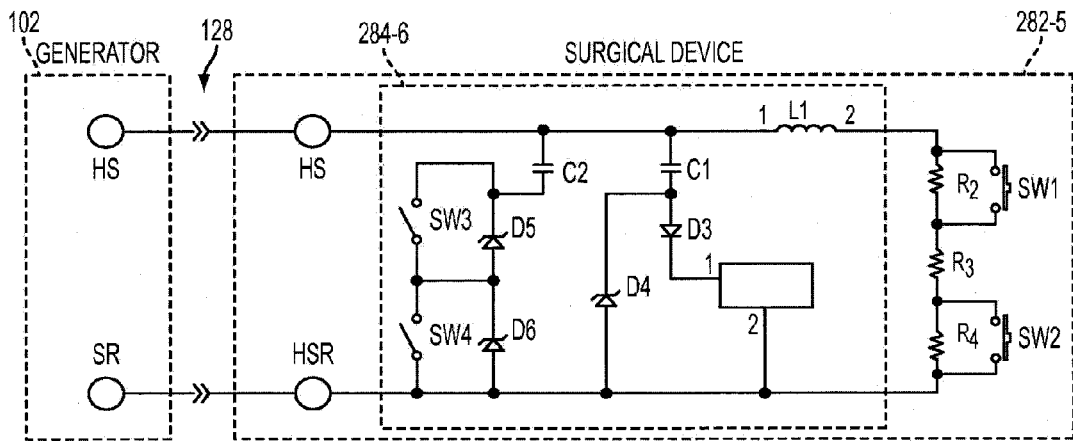

FIG. 23

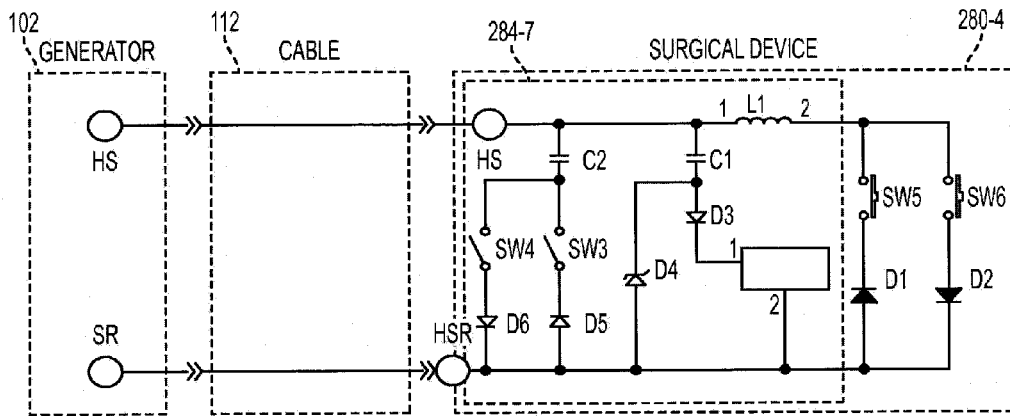

FIG. 24

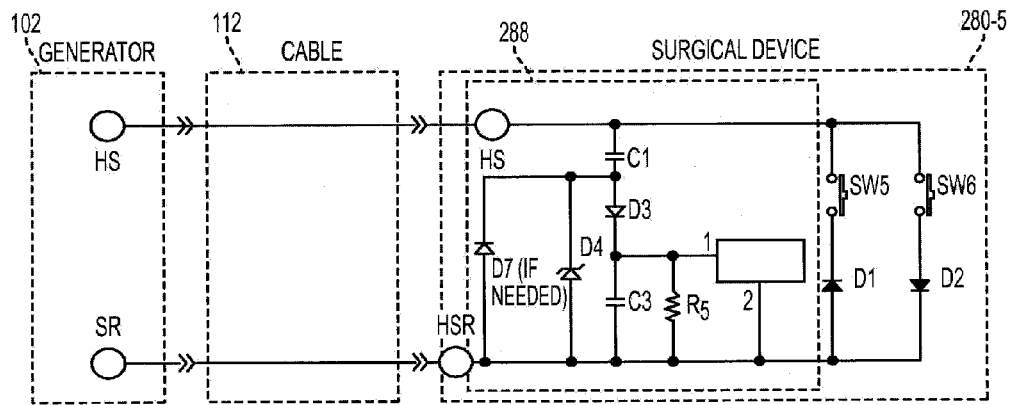

FIG. 25

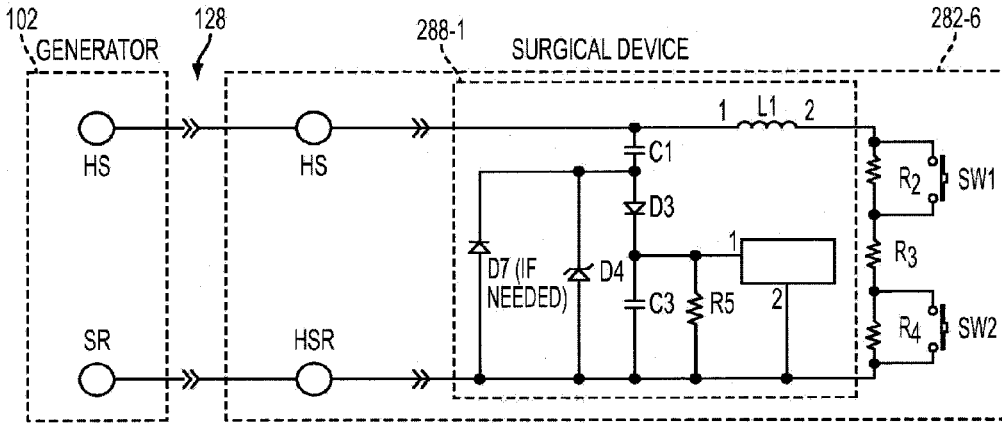

FIG. 26

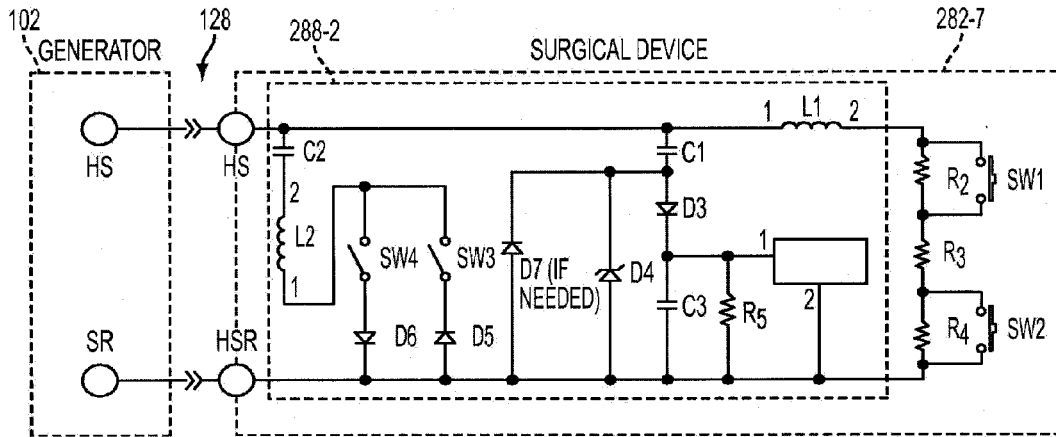

FIG. 27

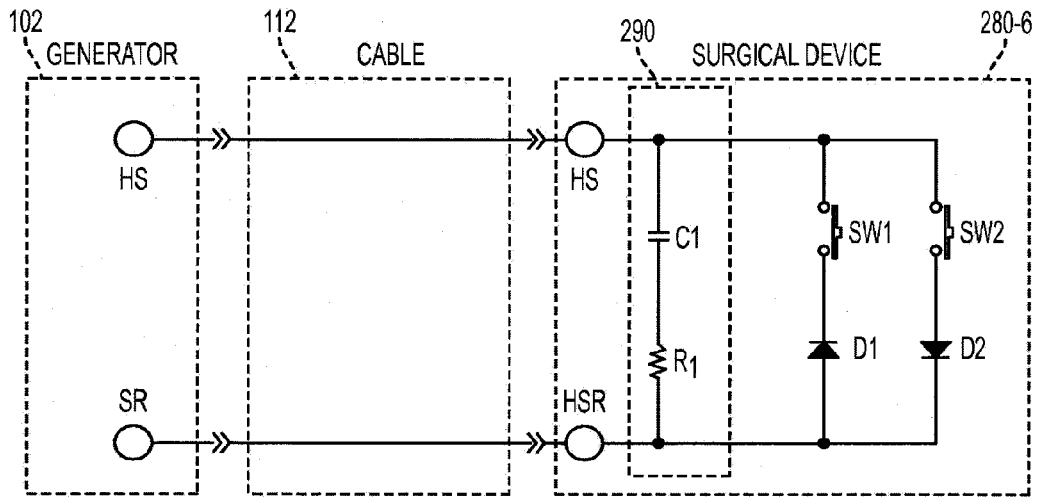

FIG. 28

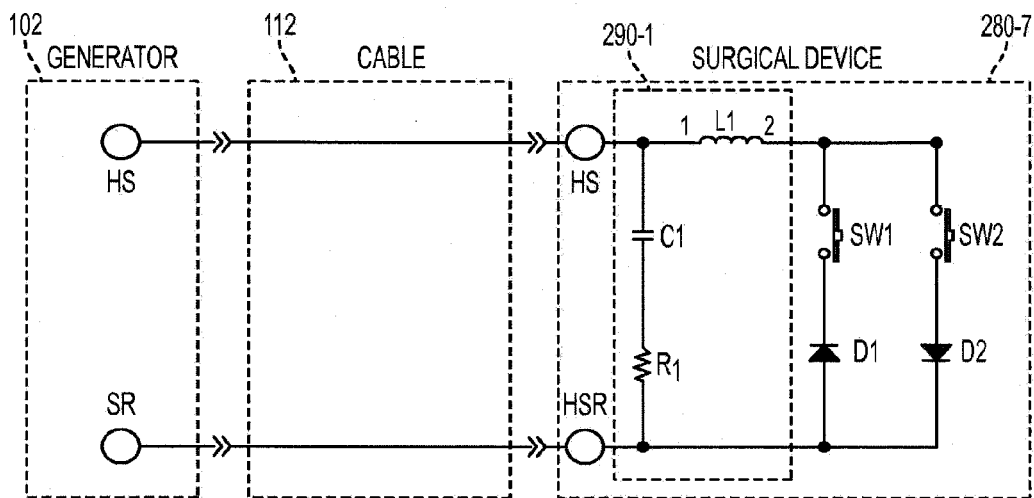

FIG. 29

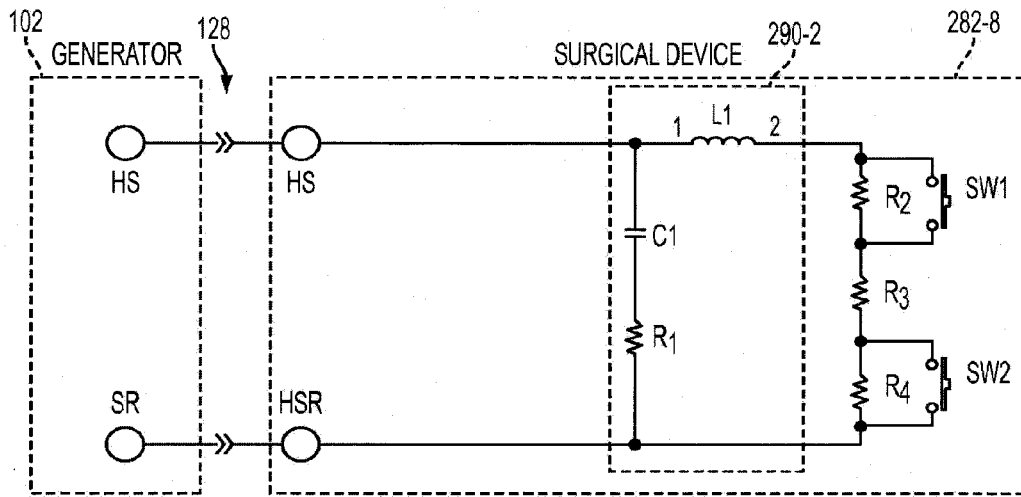

FIG. 30

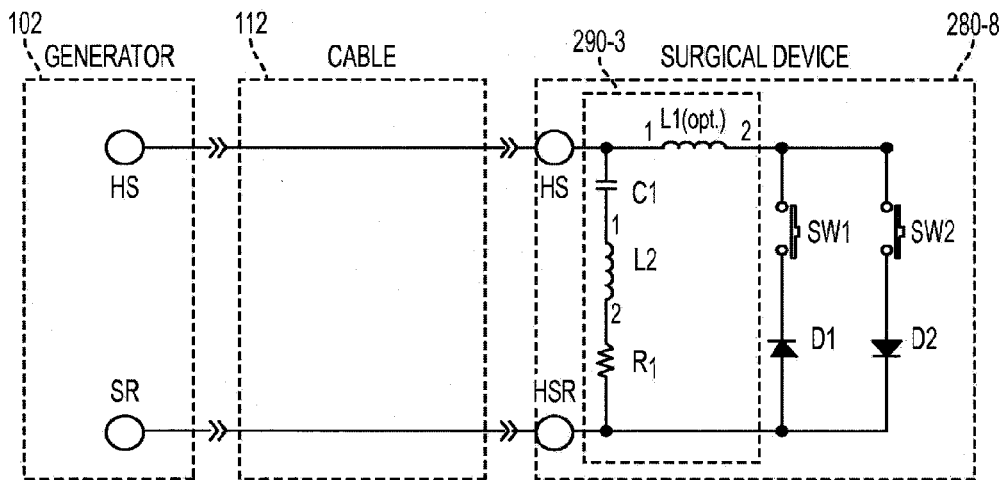

FIG. 31



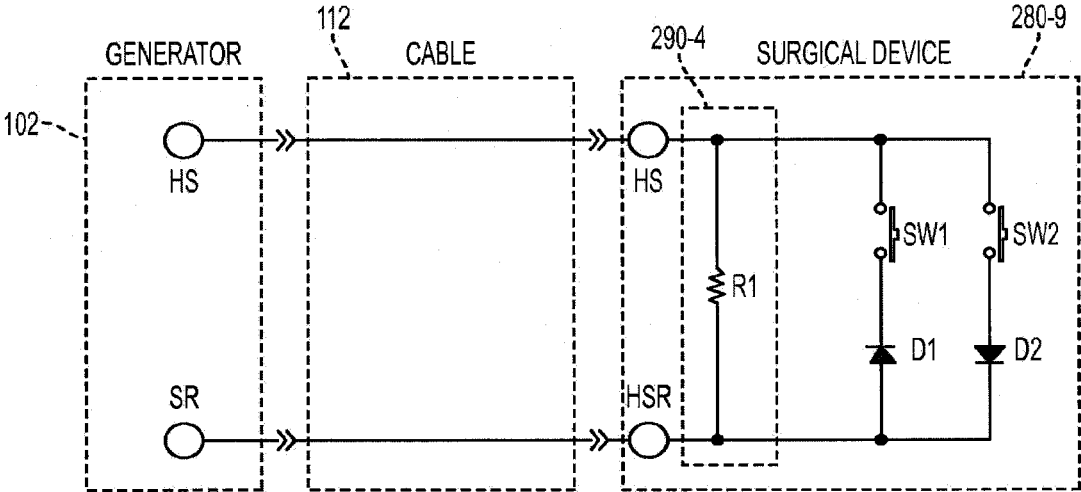

FIG. 32

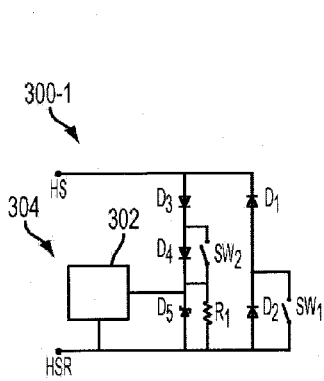

FIG. 33A

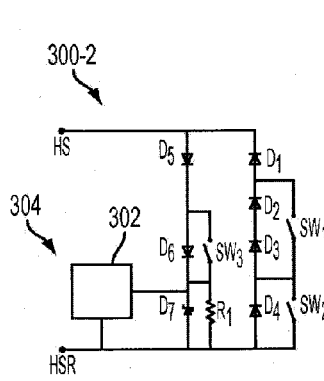

FIG. 33B

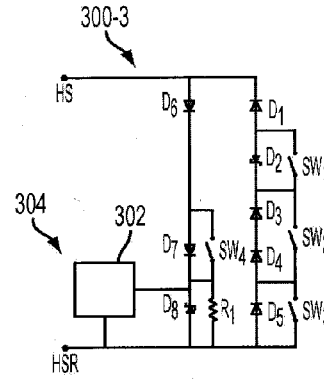

FIG. 33C

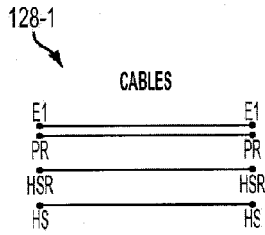

FIG. 33D

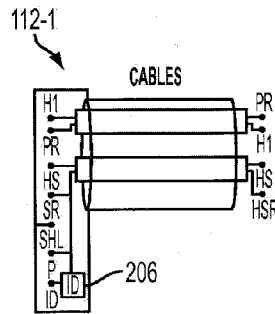

FIG. 33E

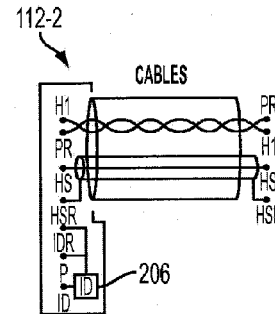

FIG. 33F

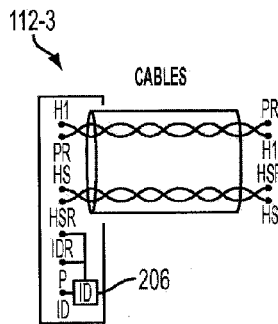

FIG. 33G

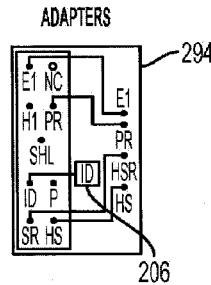

FIG. 33H

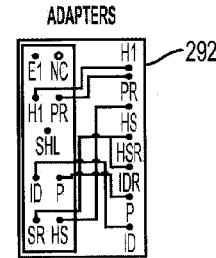

FIG. 33I

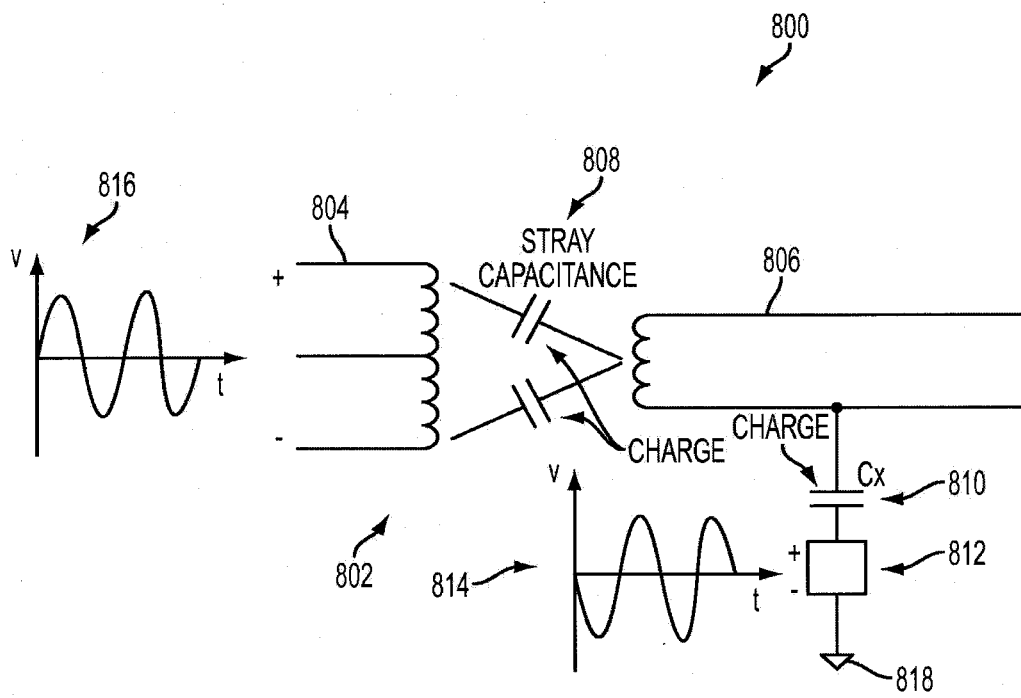

FIG. 34



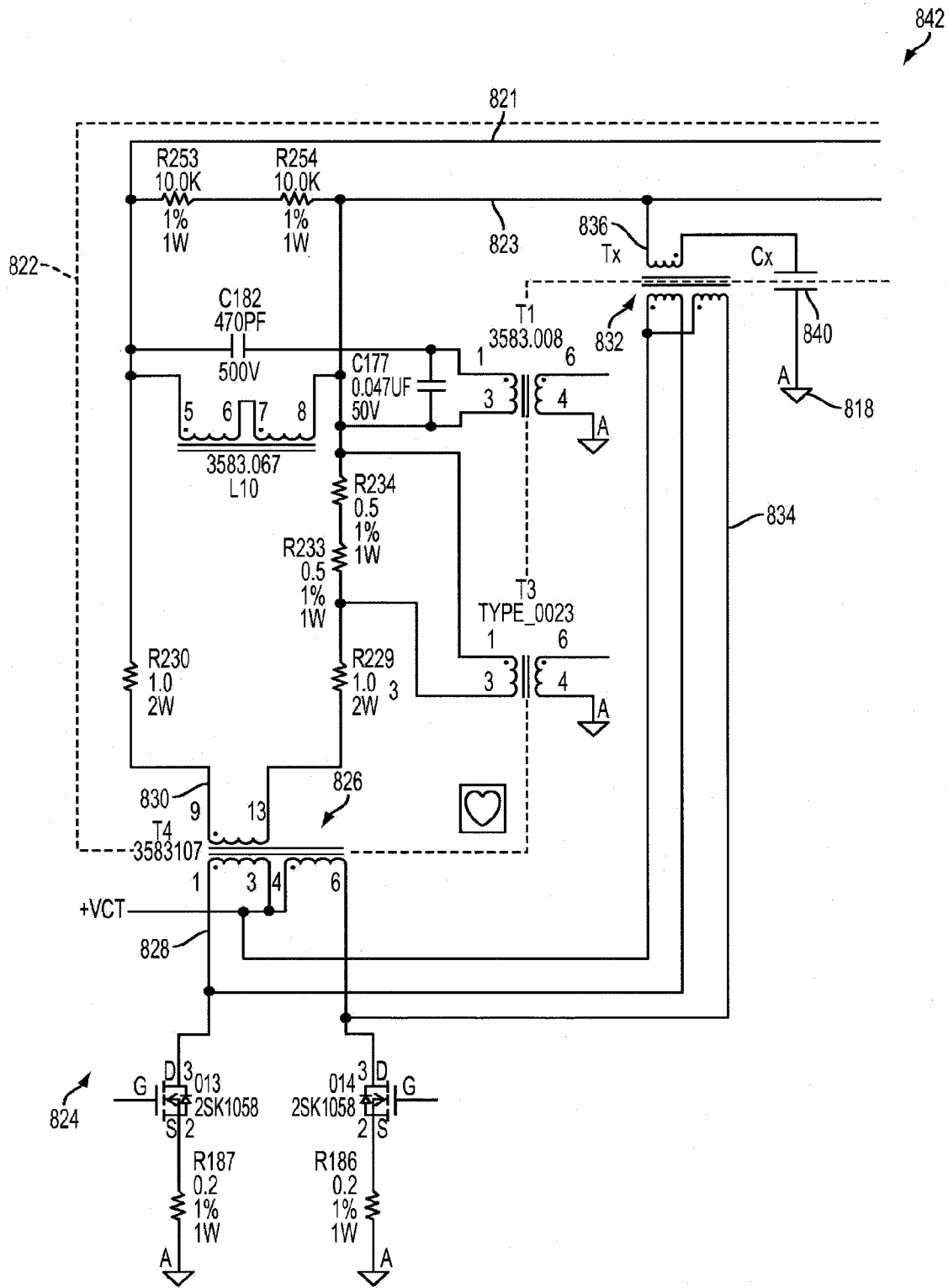

FIG. 36

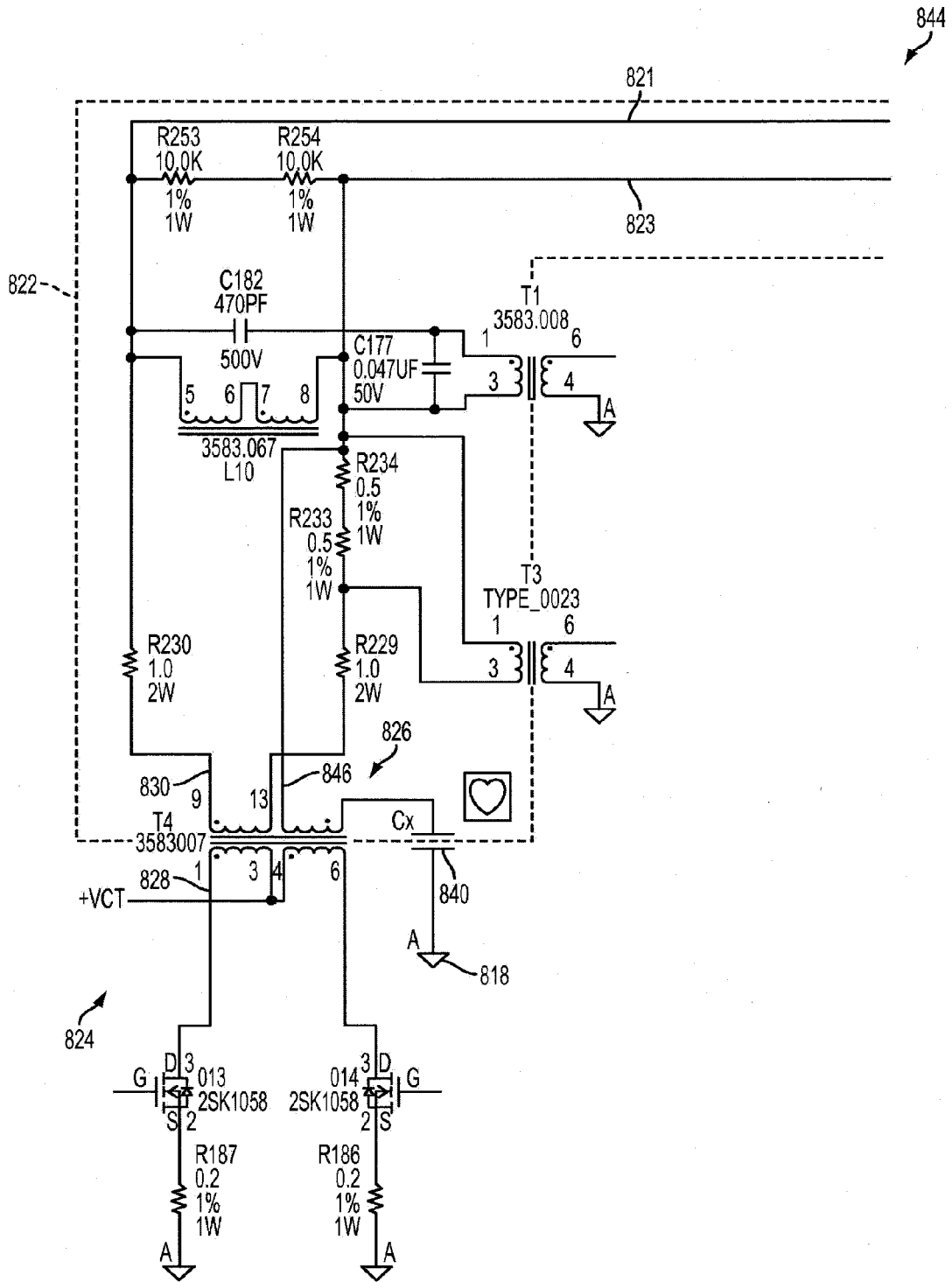

FIG. 37

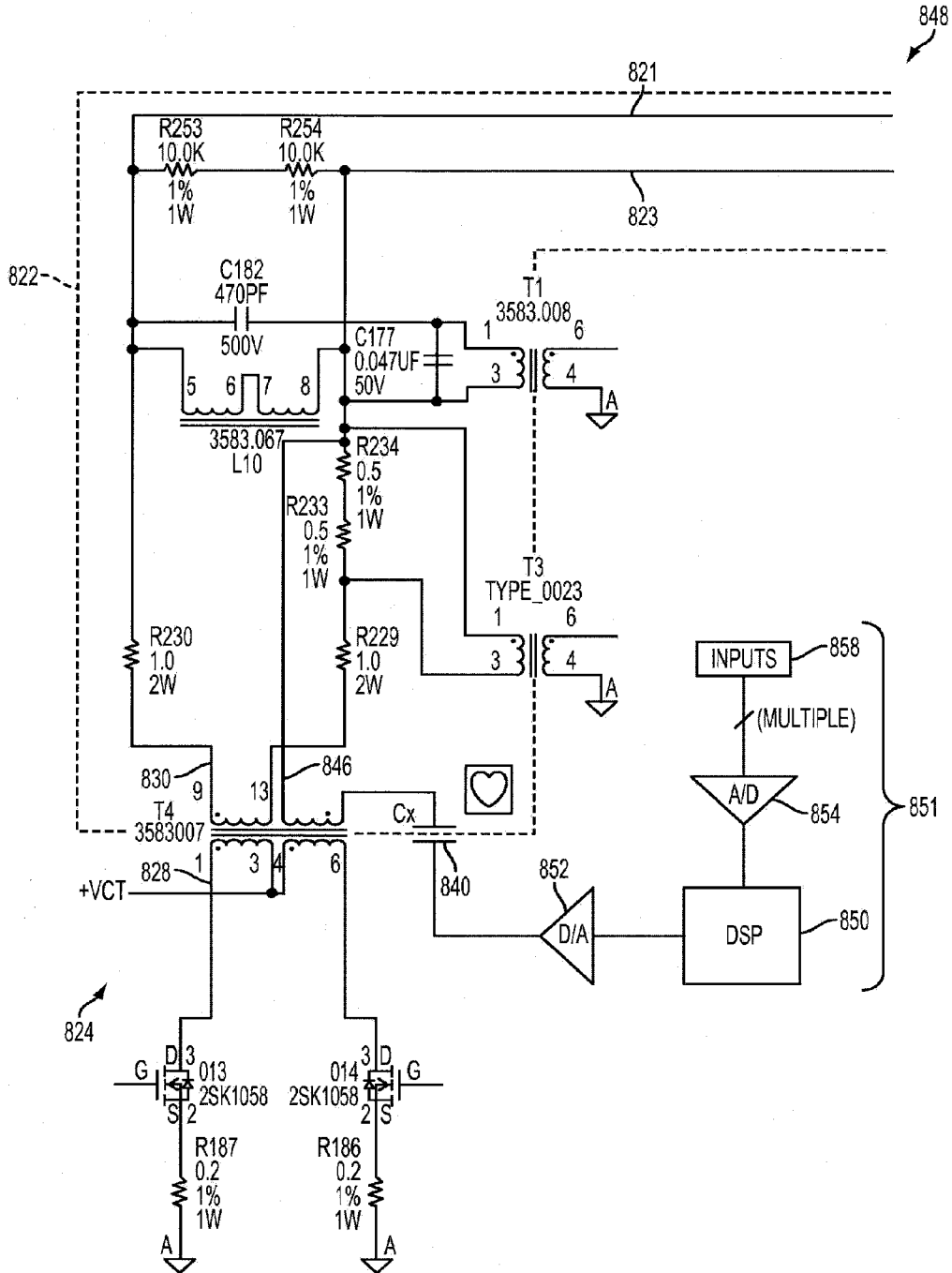

FIG. 38







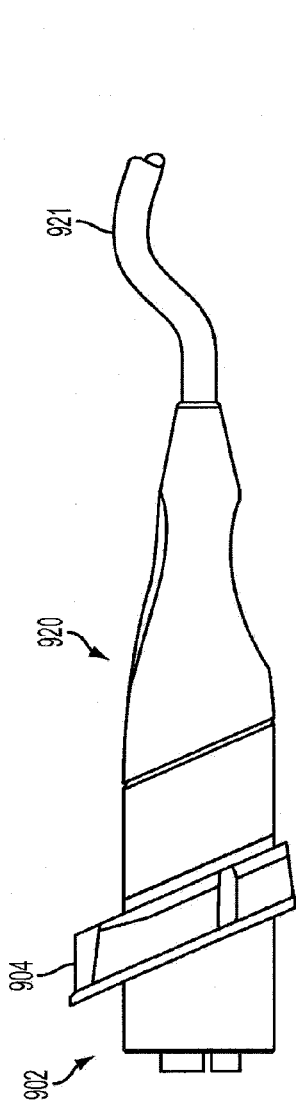

FIG. 41

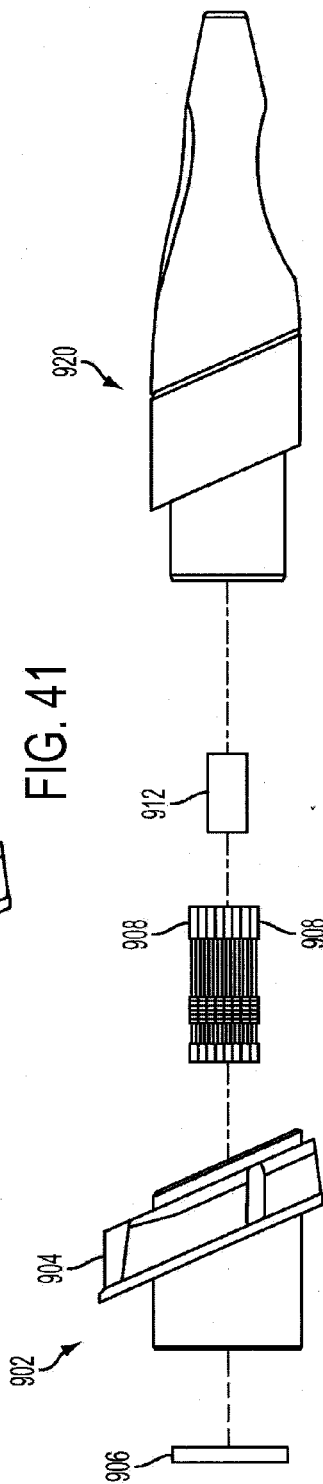

FIG. 42

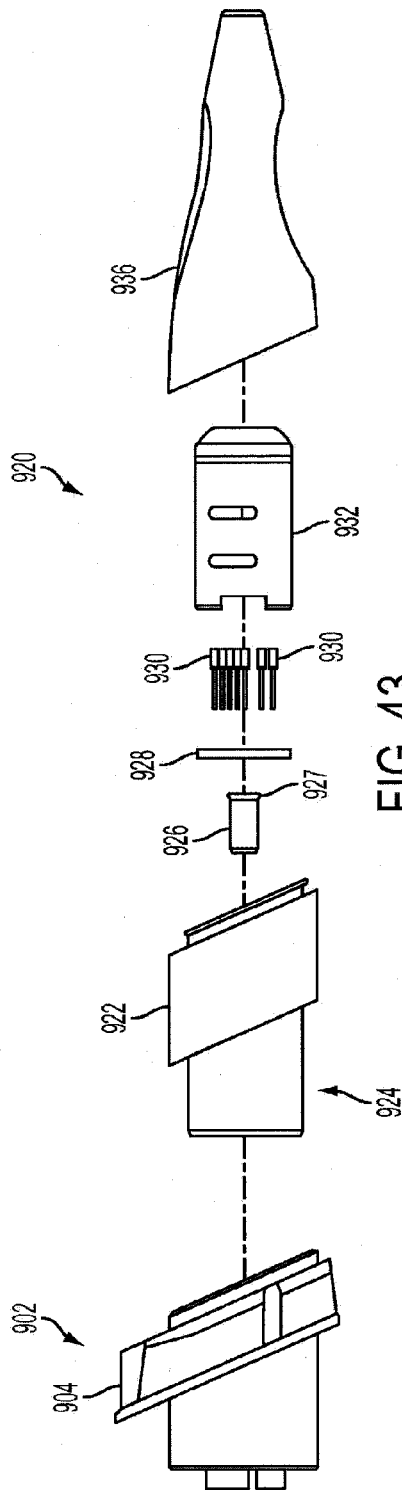

FIG. 43

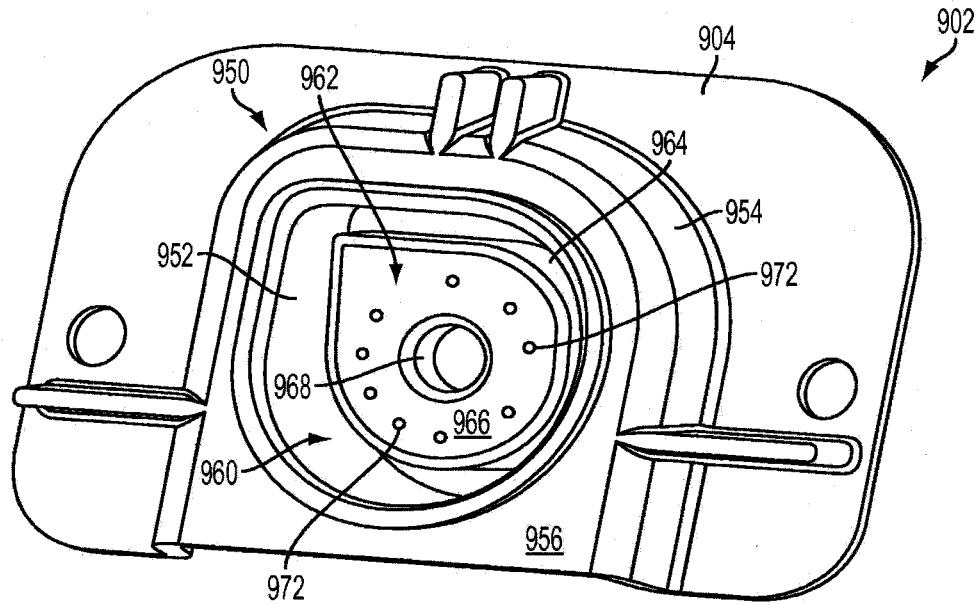

FIG. 44

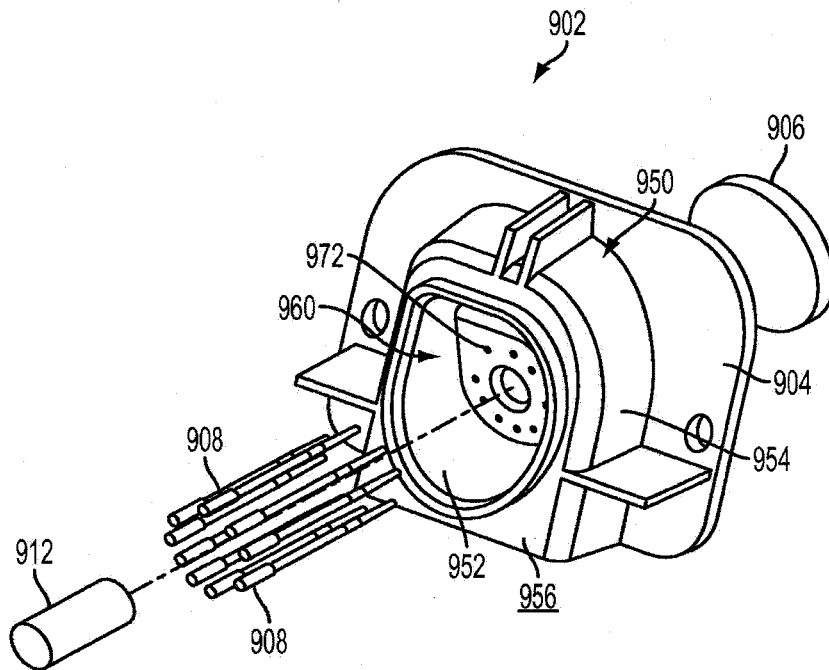

FIG. 45

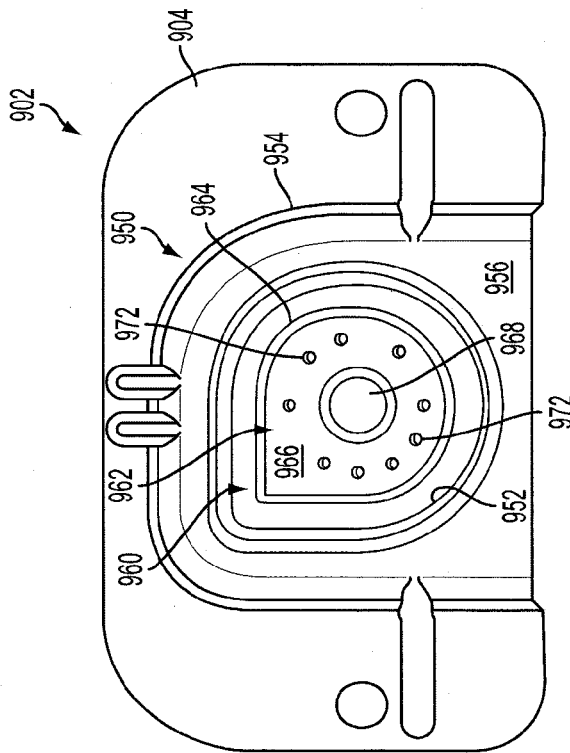

FIG. 46

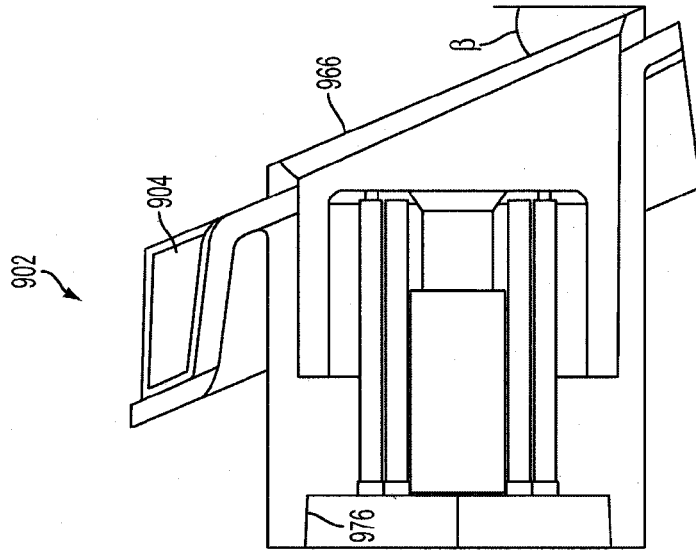

FIG. 47

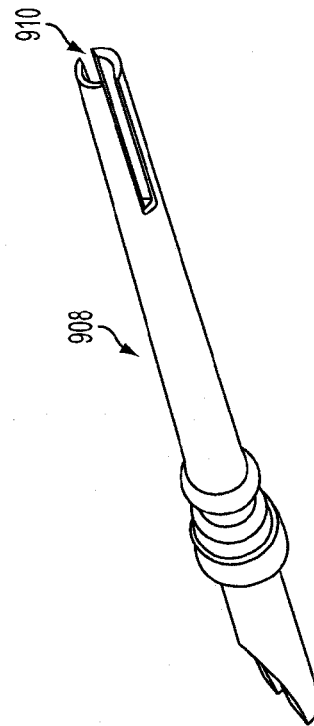

FIG. 48

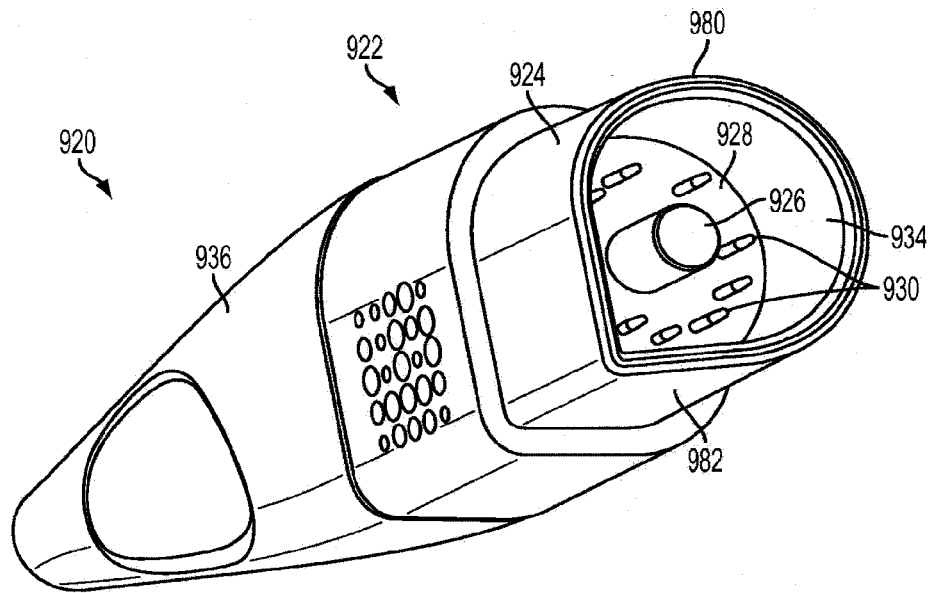

FIG. 49

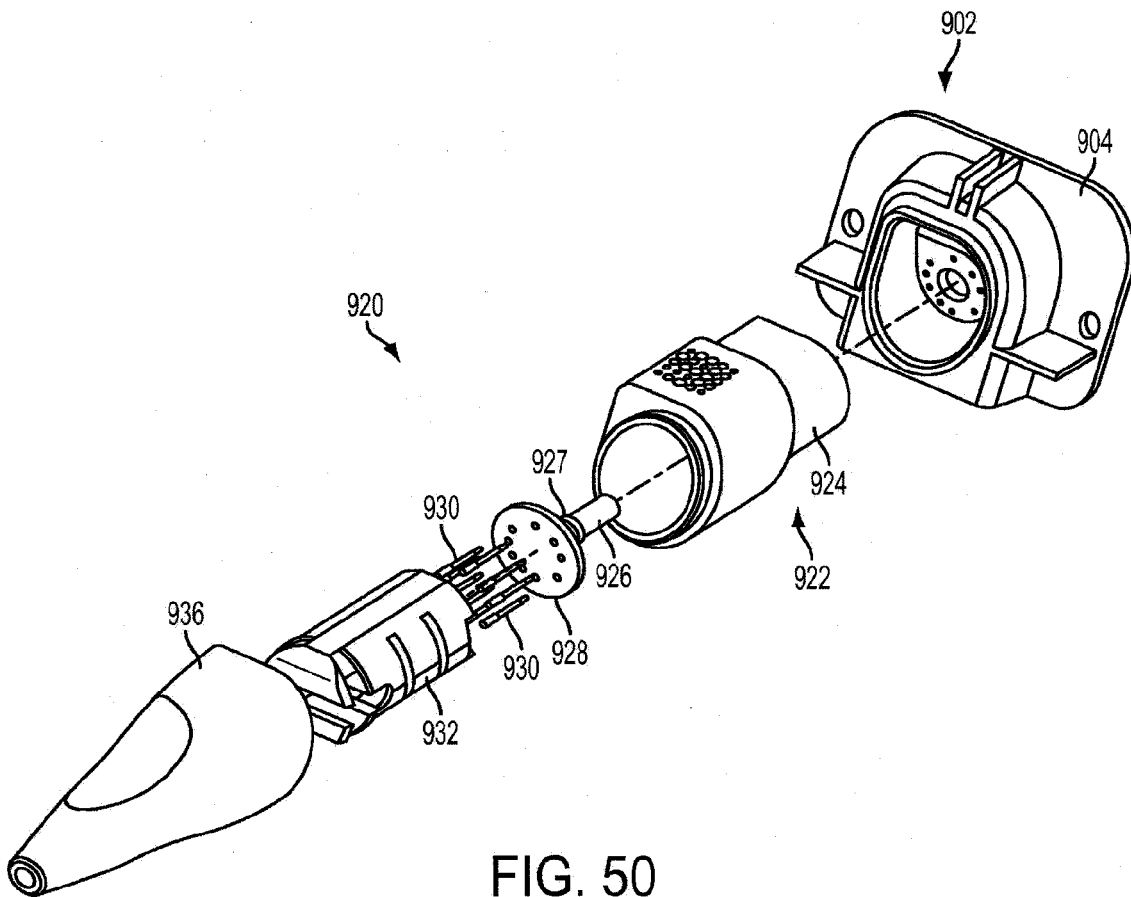

FIG. 50

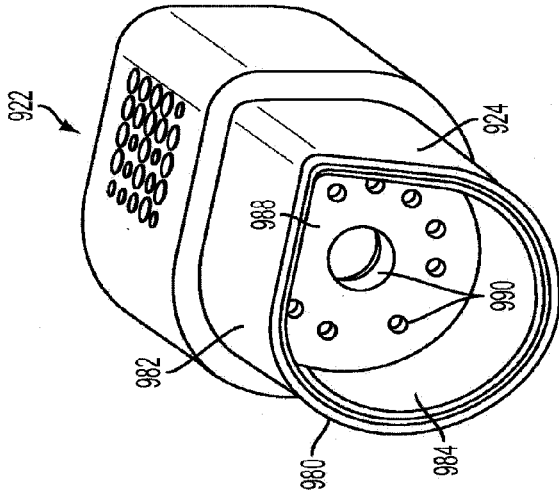

FIG. 52

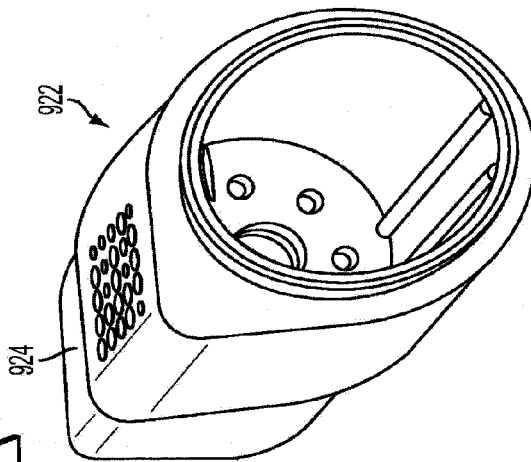

FIG. 53

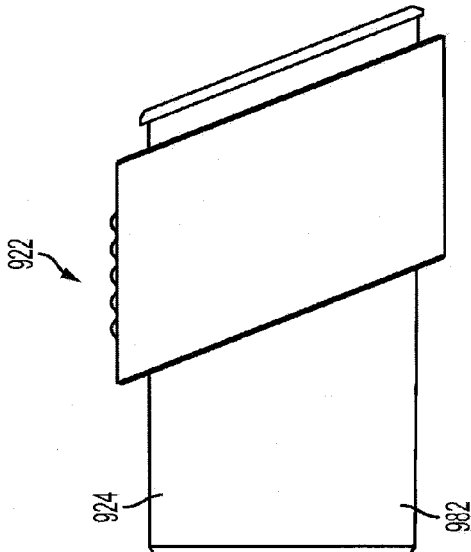

FIG. 51

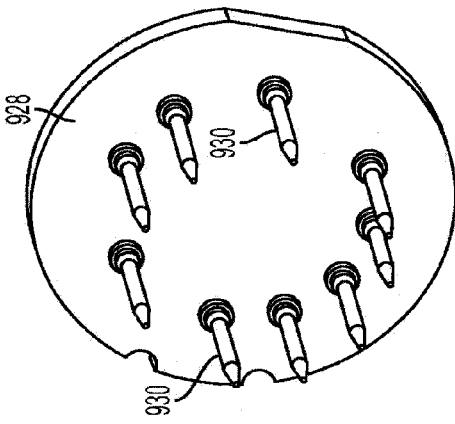

FIG. 55

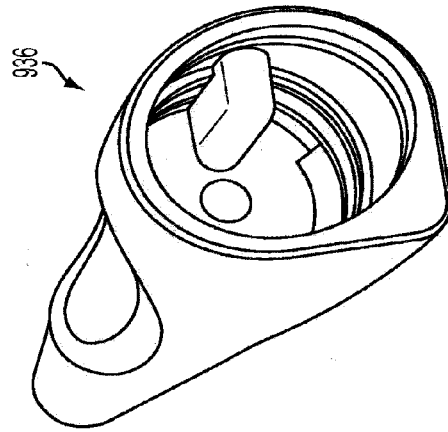

FIG. 57

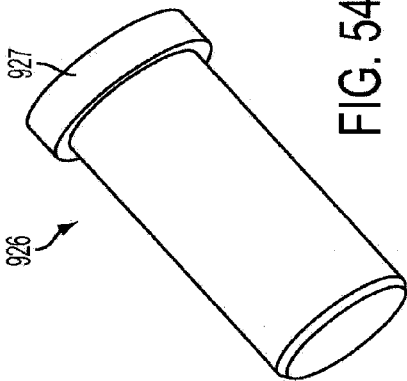

FIG. 54

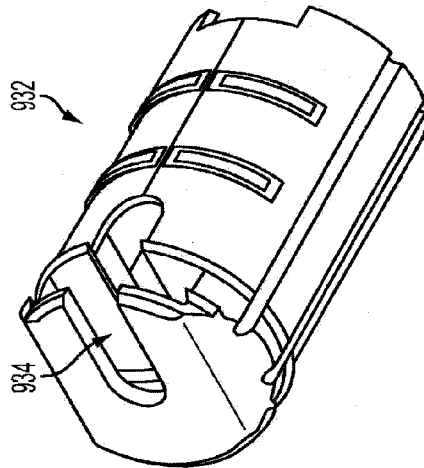
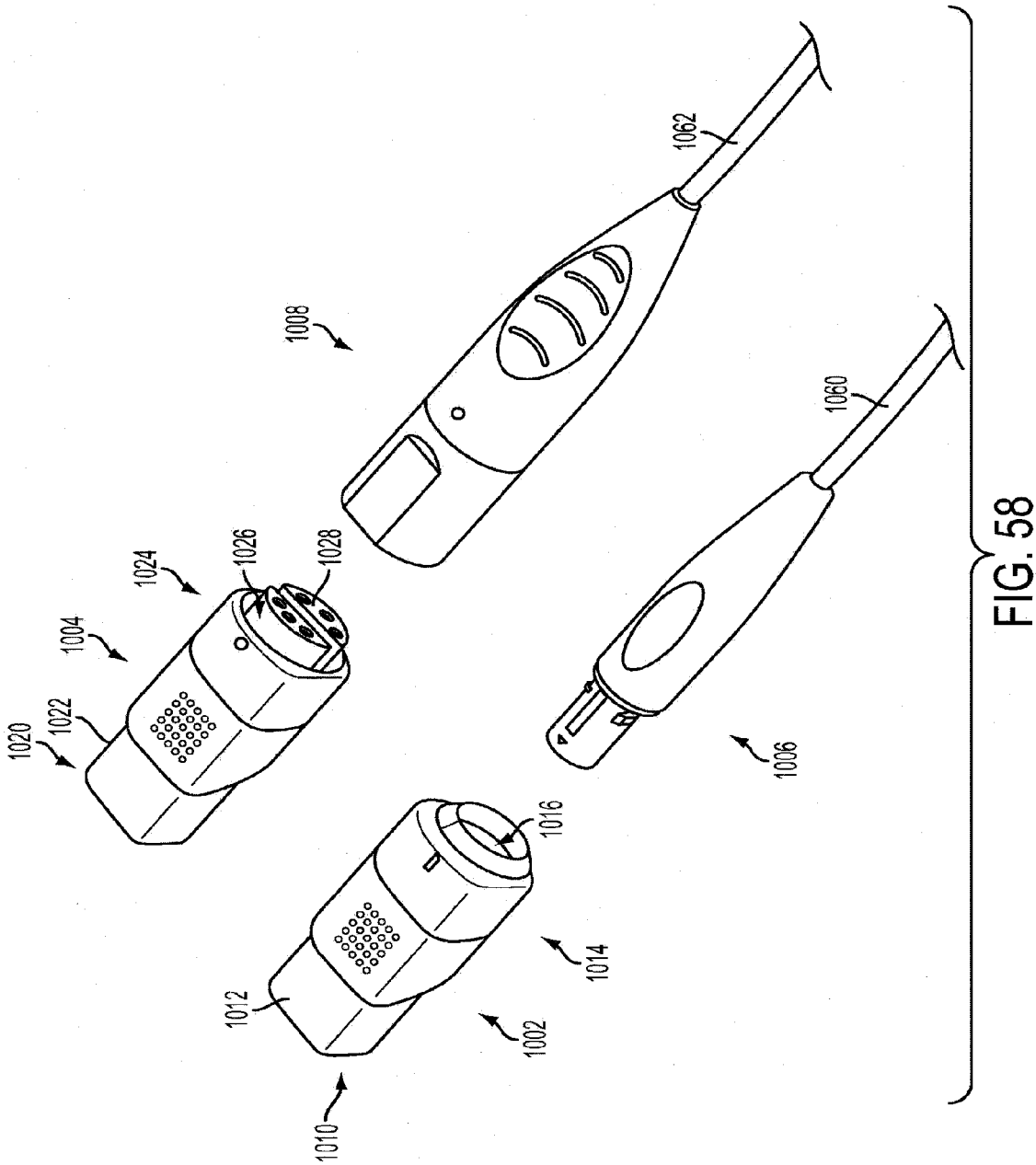

FIG. 56





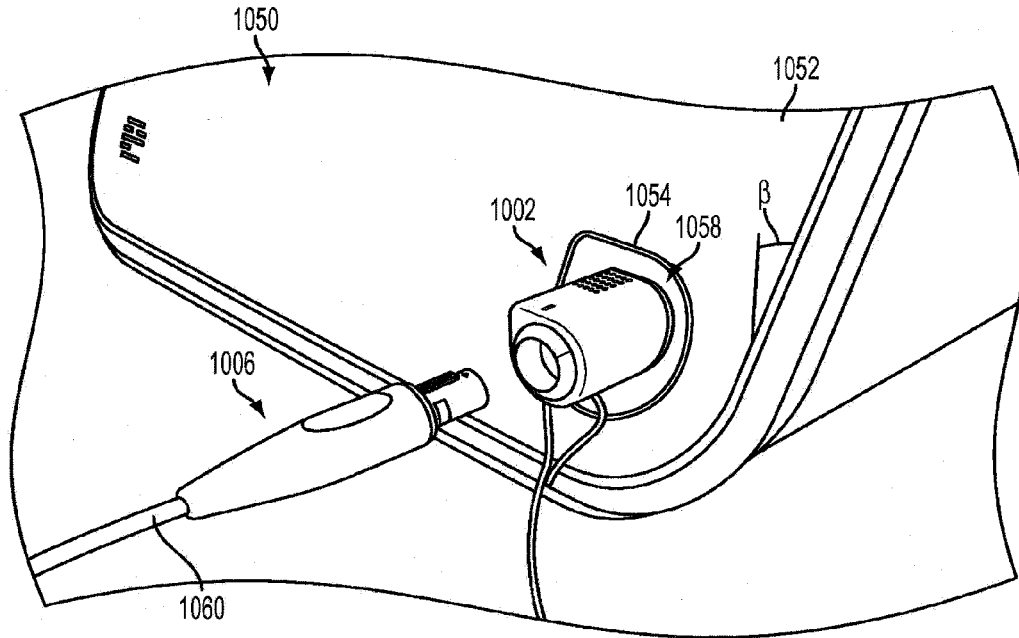

FIG. 59

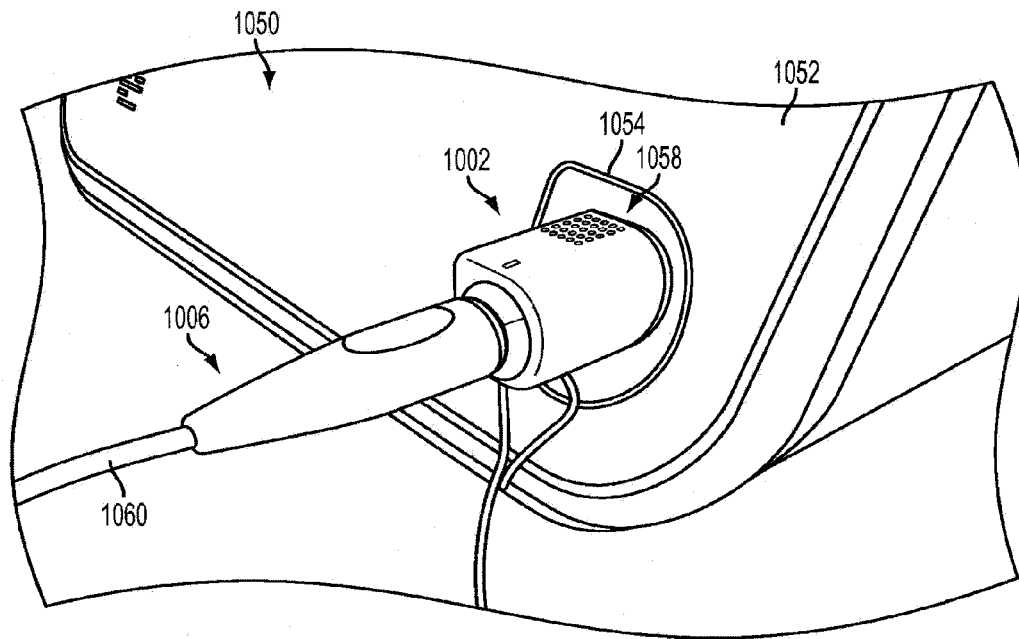

FIG. 60

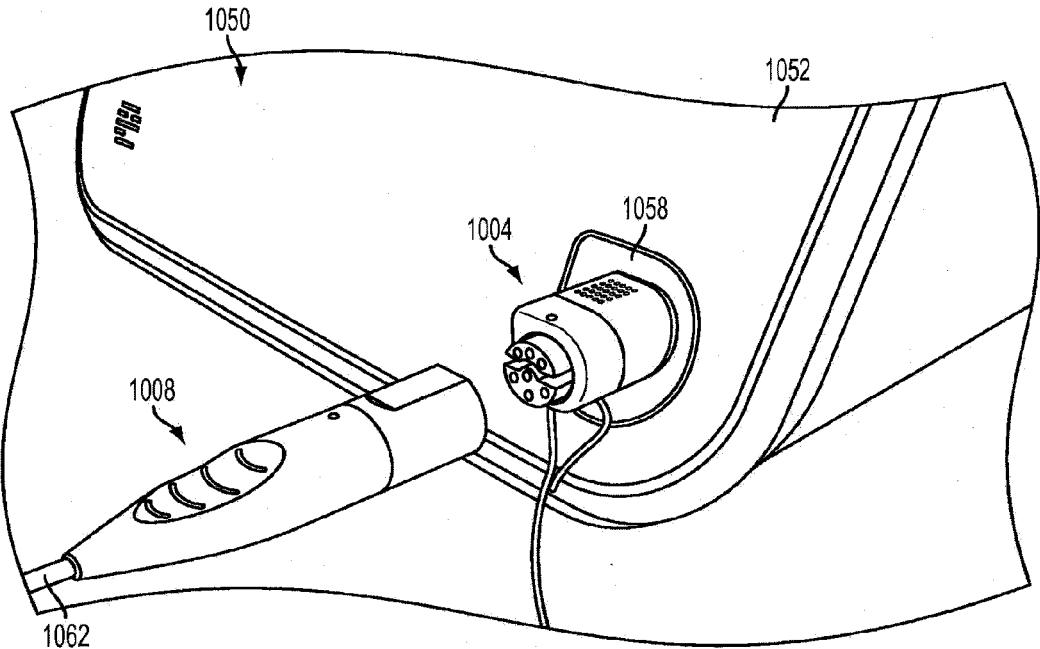

FIG. 61

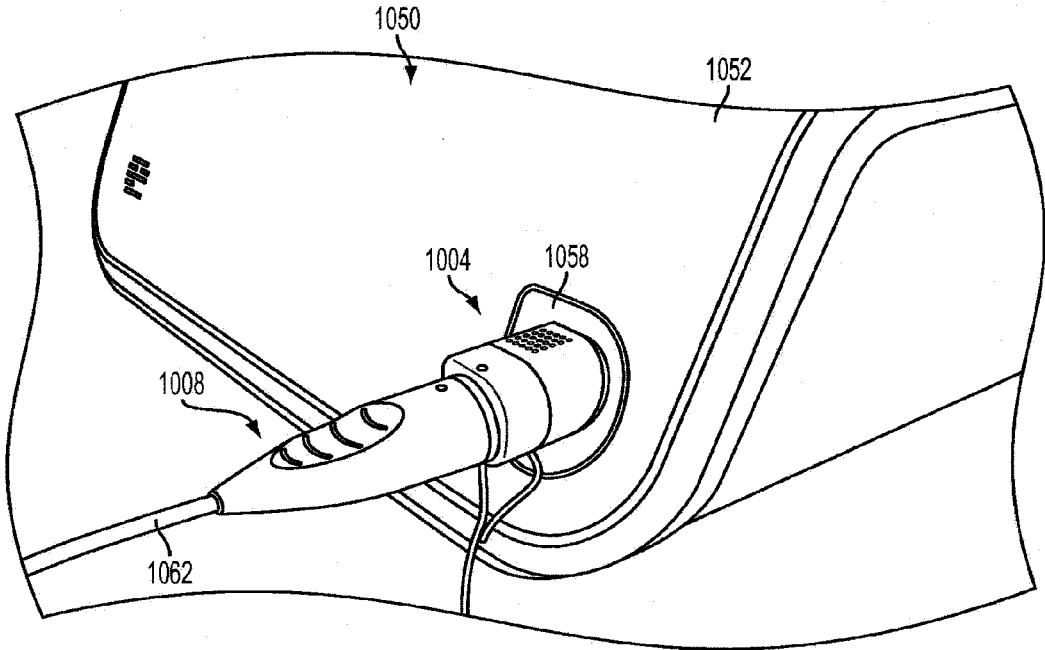

FIG. 62

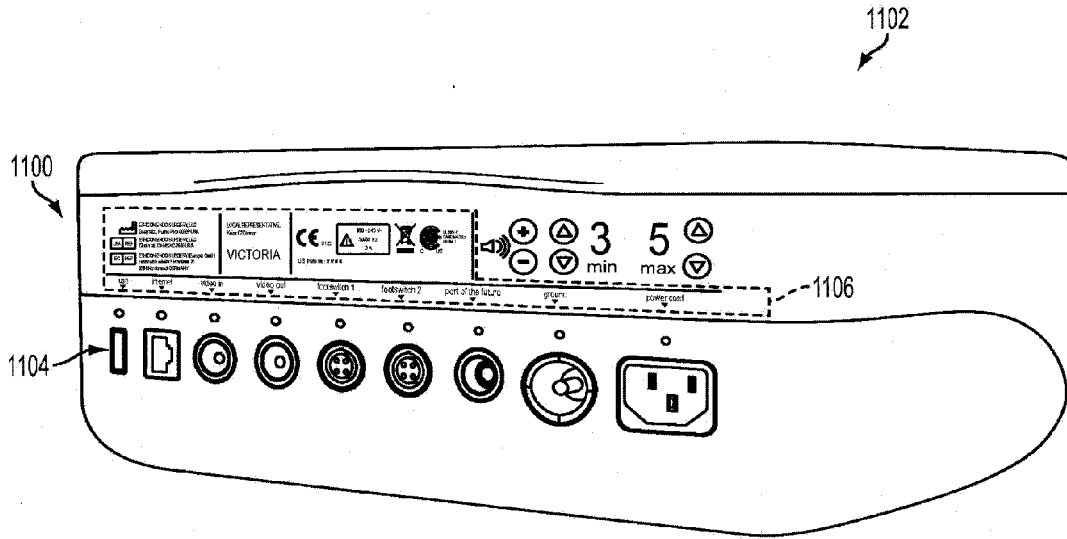

FIG. 63

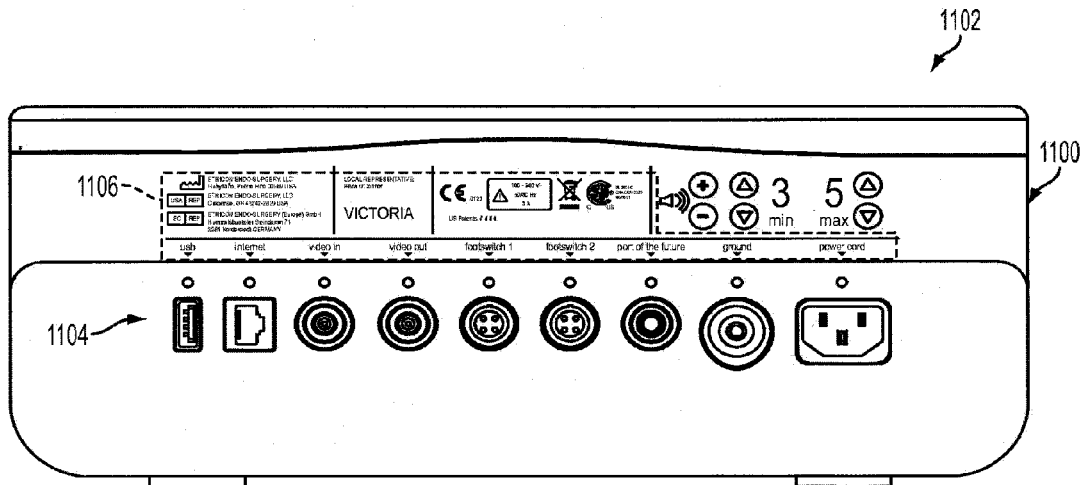

FIG. 64

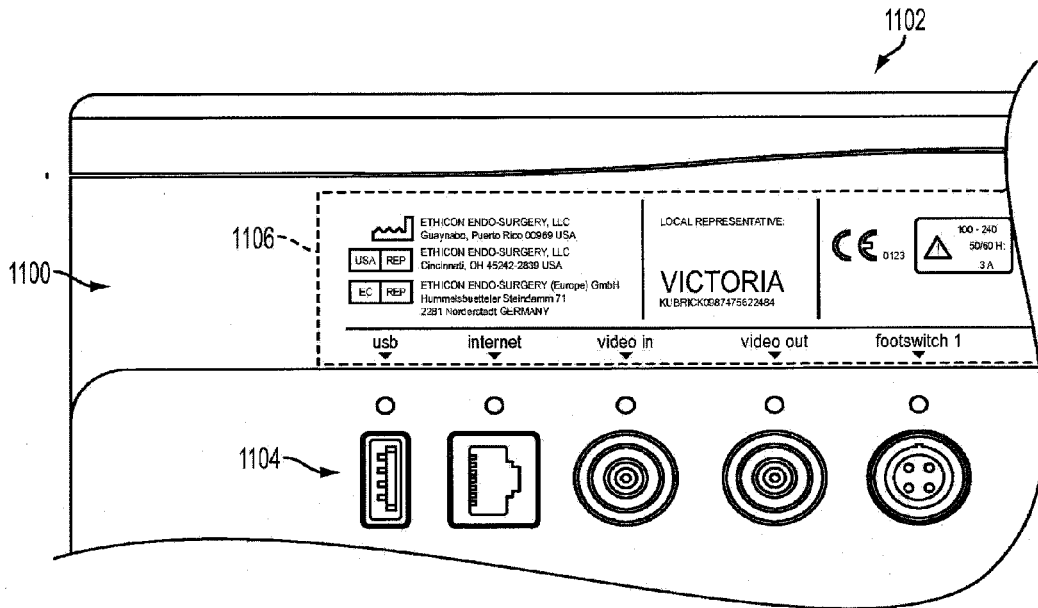

FIG. 65

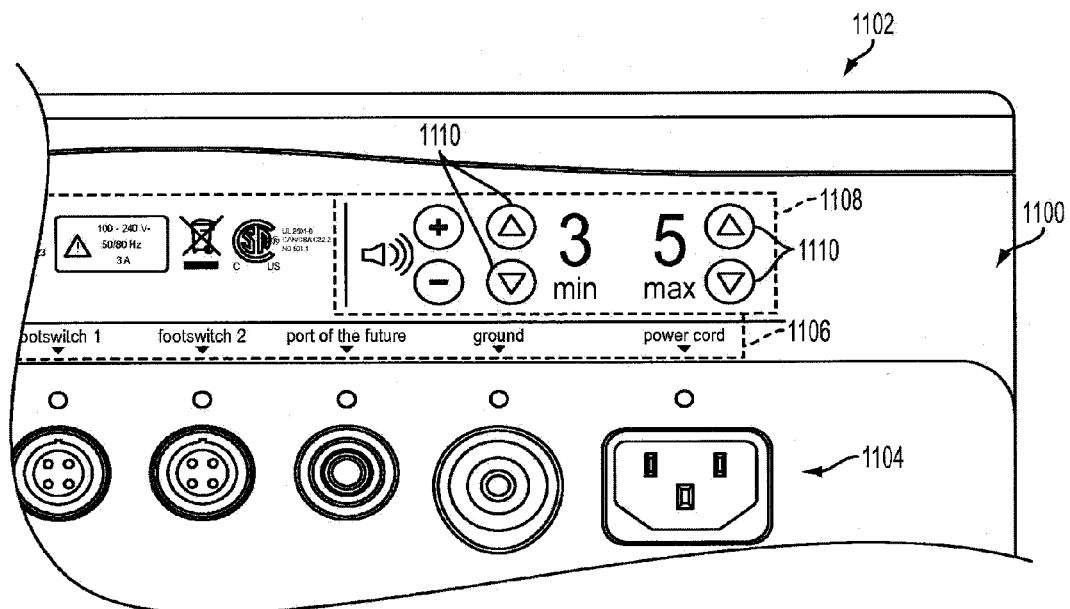

FIG. 66

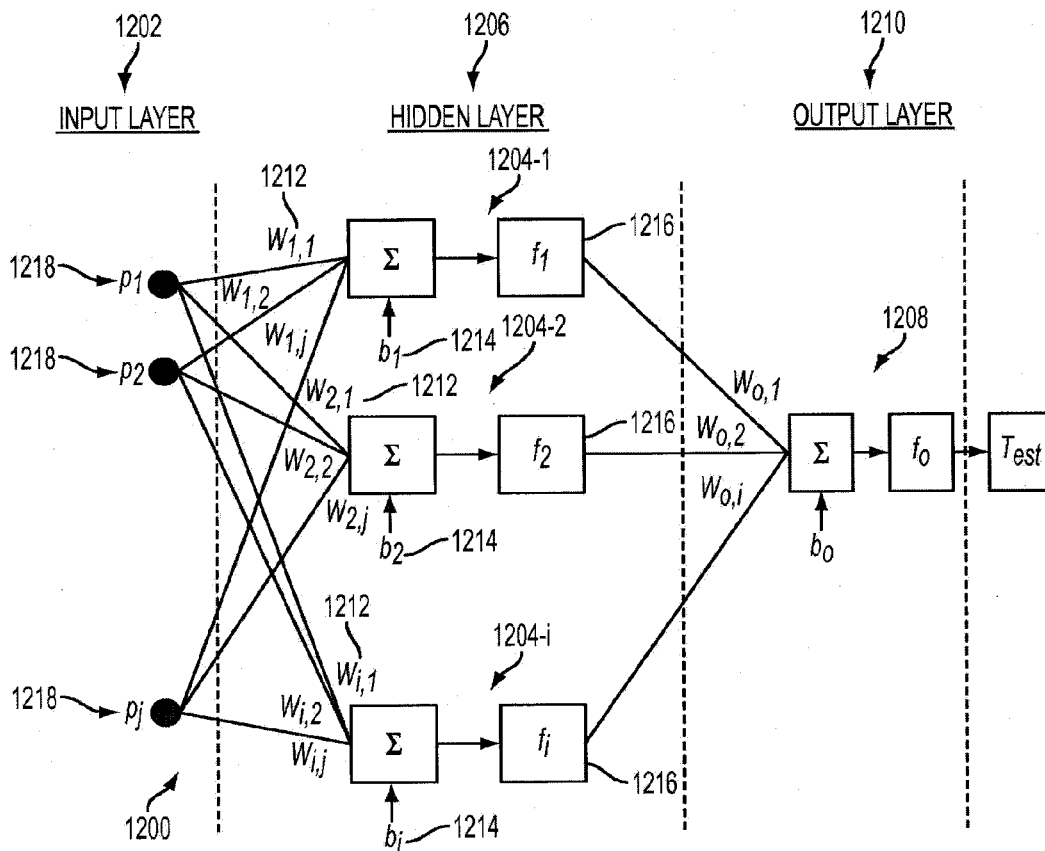
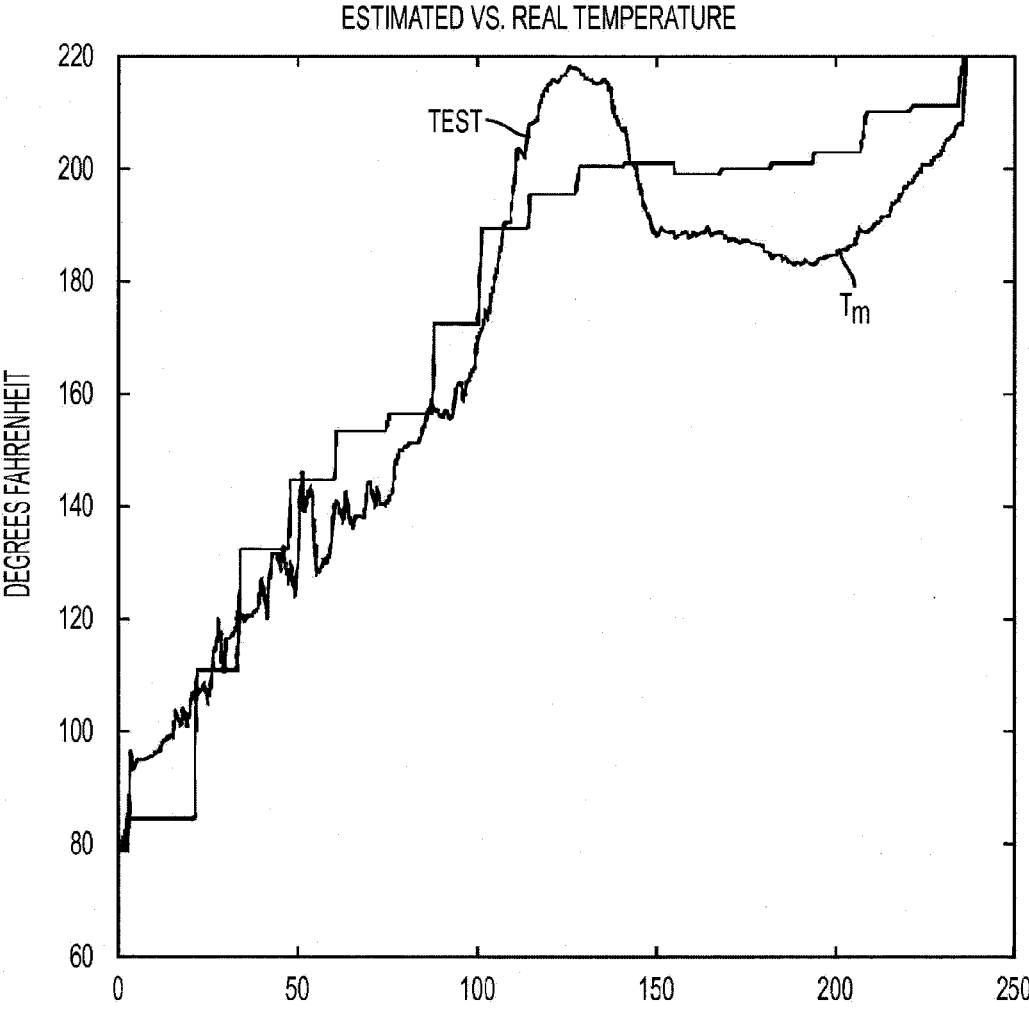

FIG. 67



SAMPLES  
FIG. 68

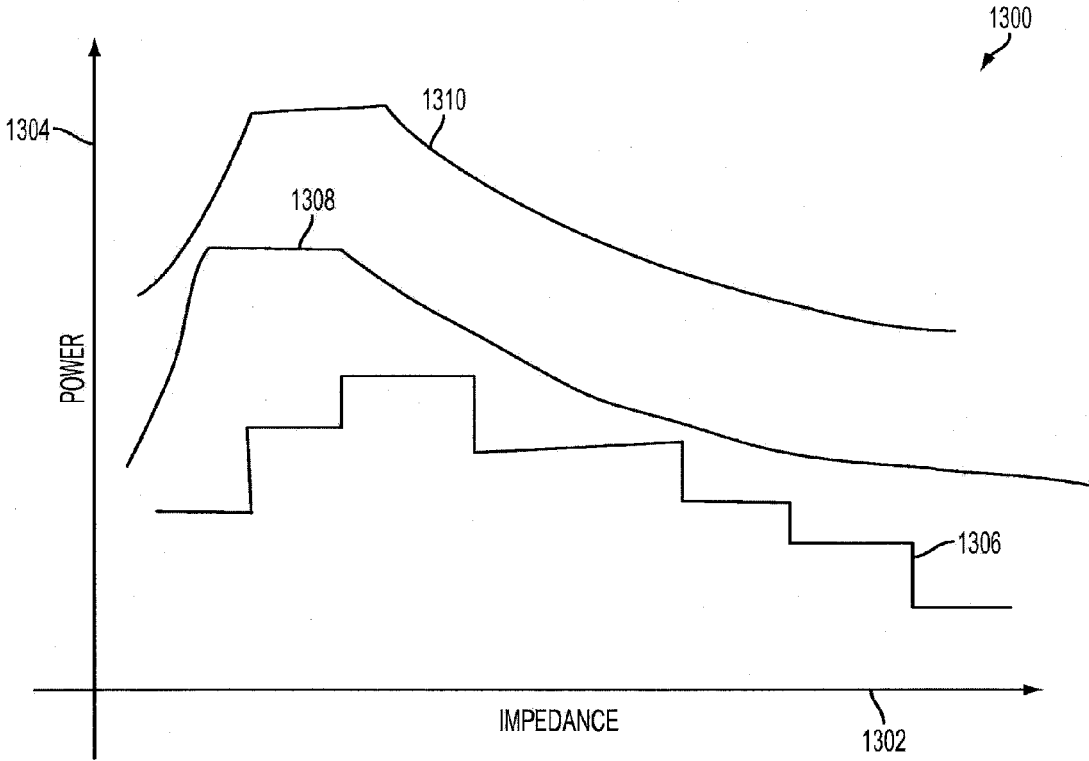

FIG. 69

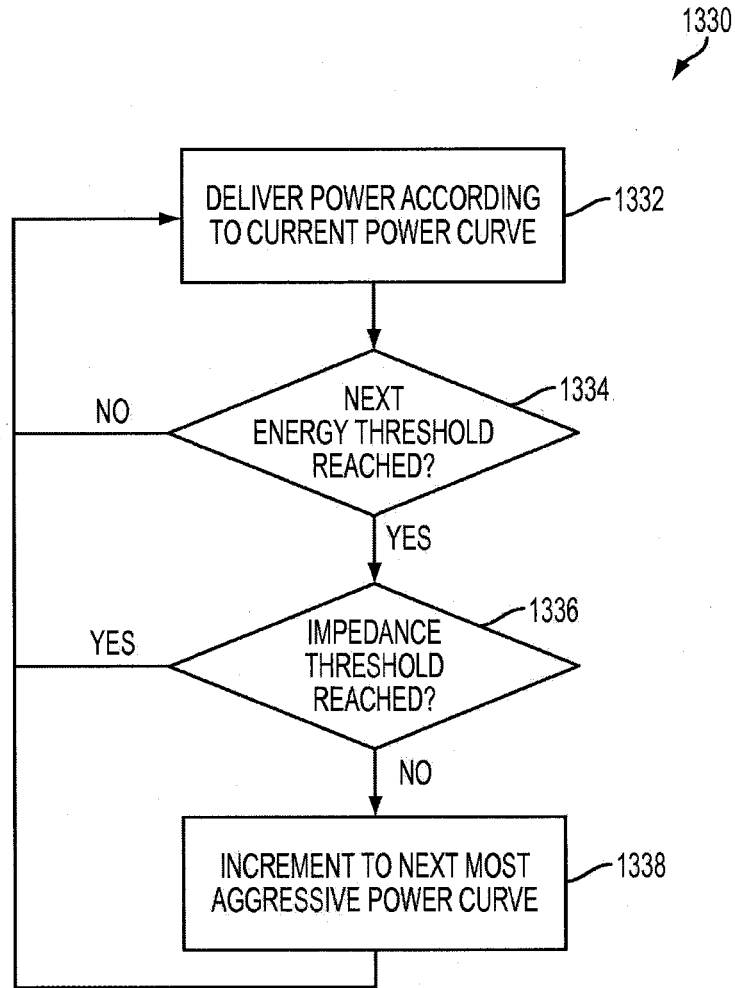

FIG. 70



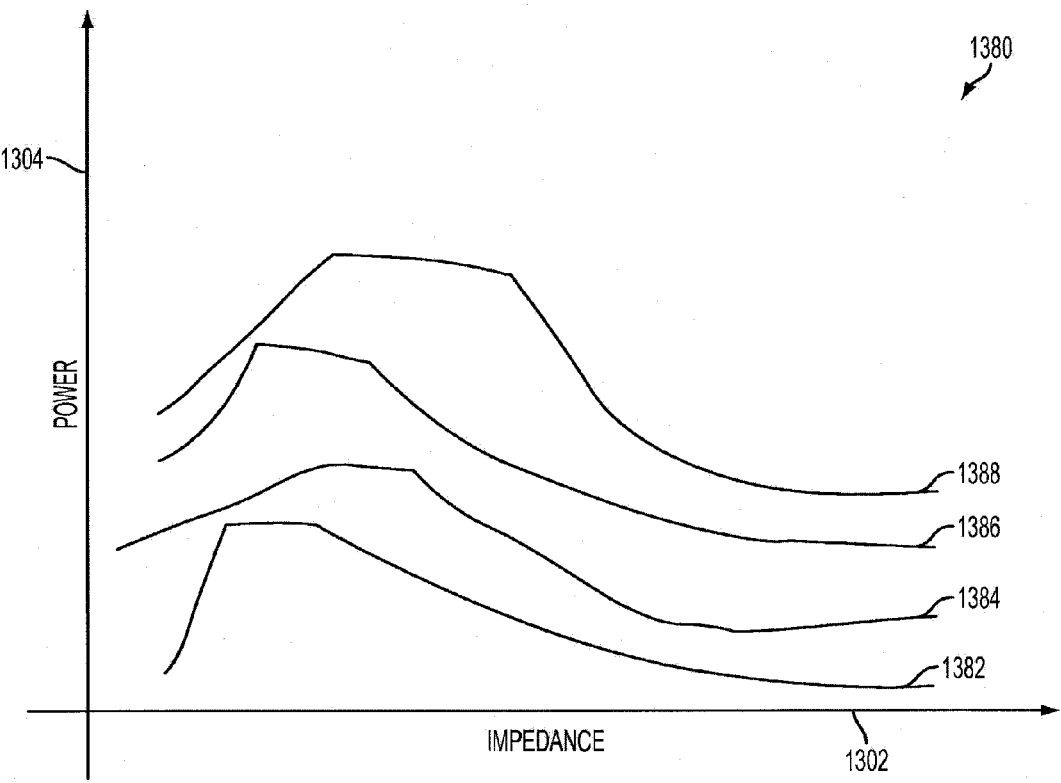

FIG. 71

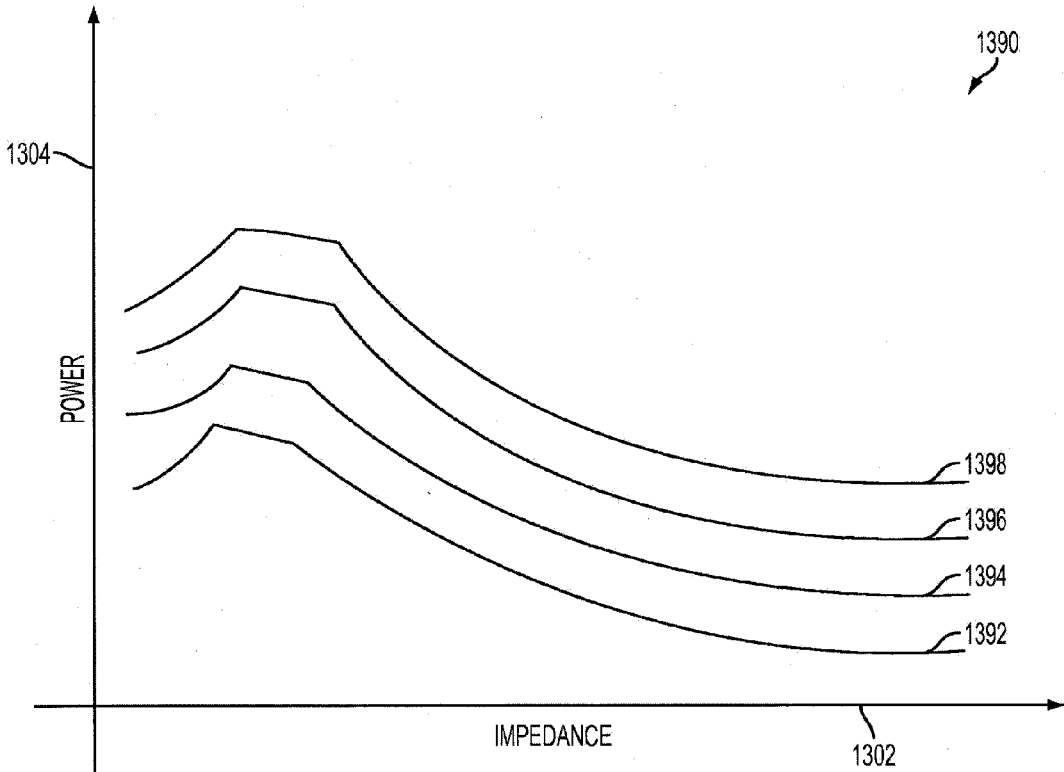

FIG. 72

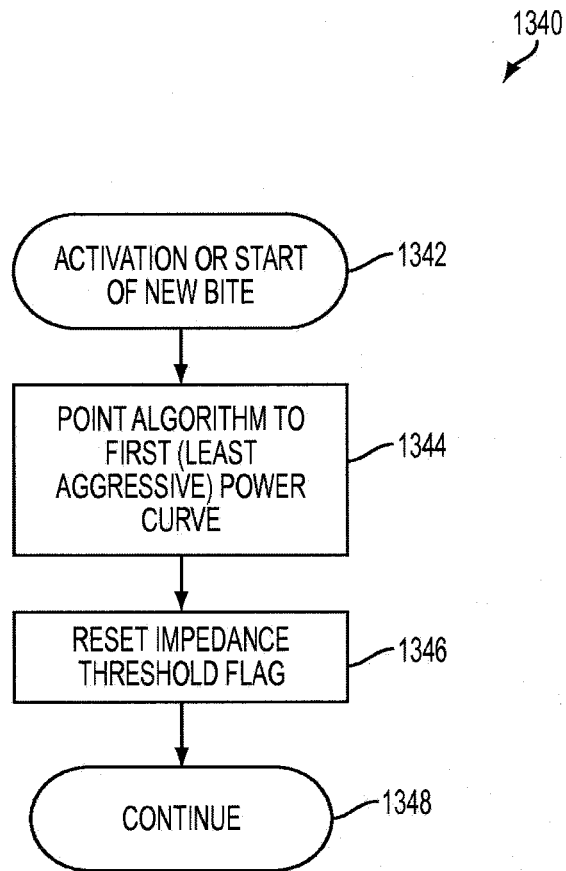

FIG. 73A

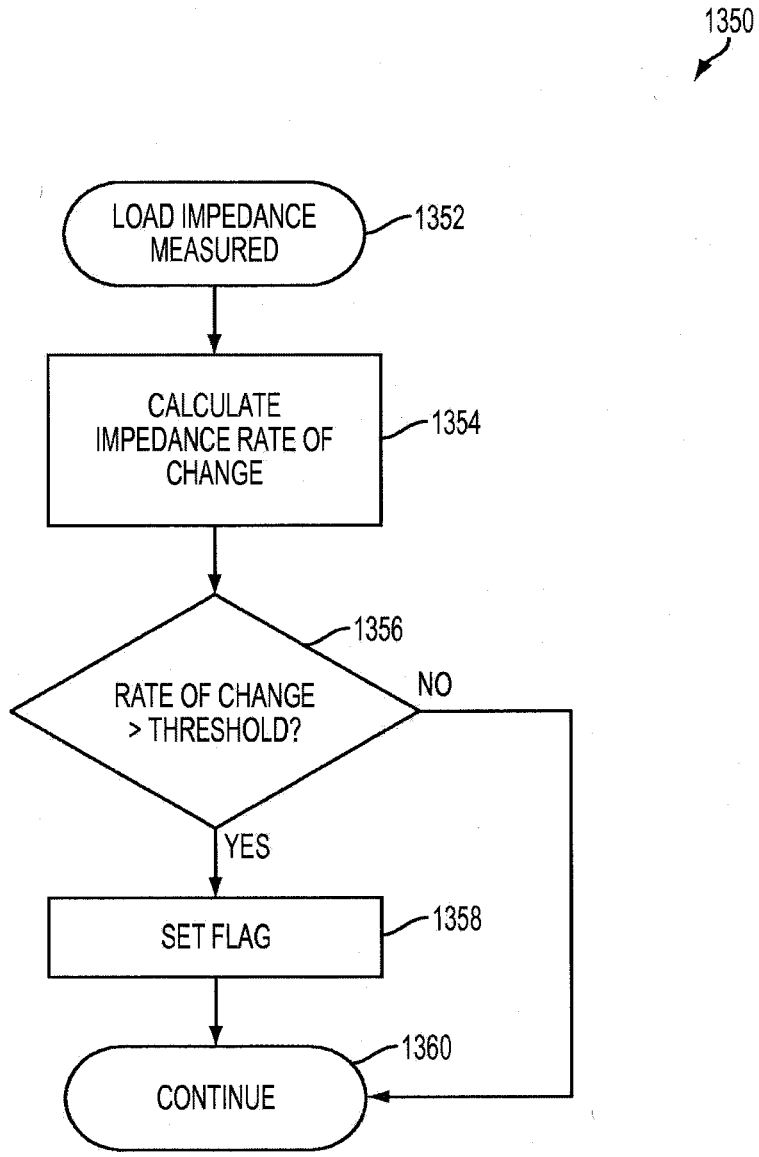

FIG. 73B

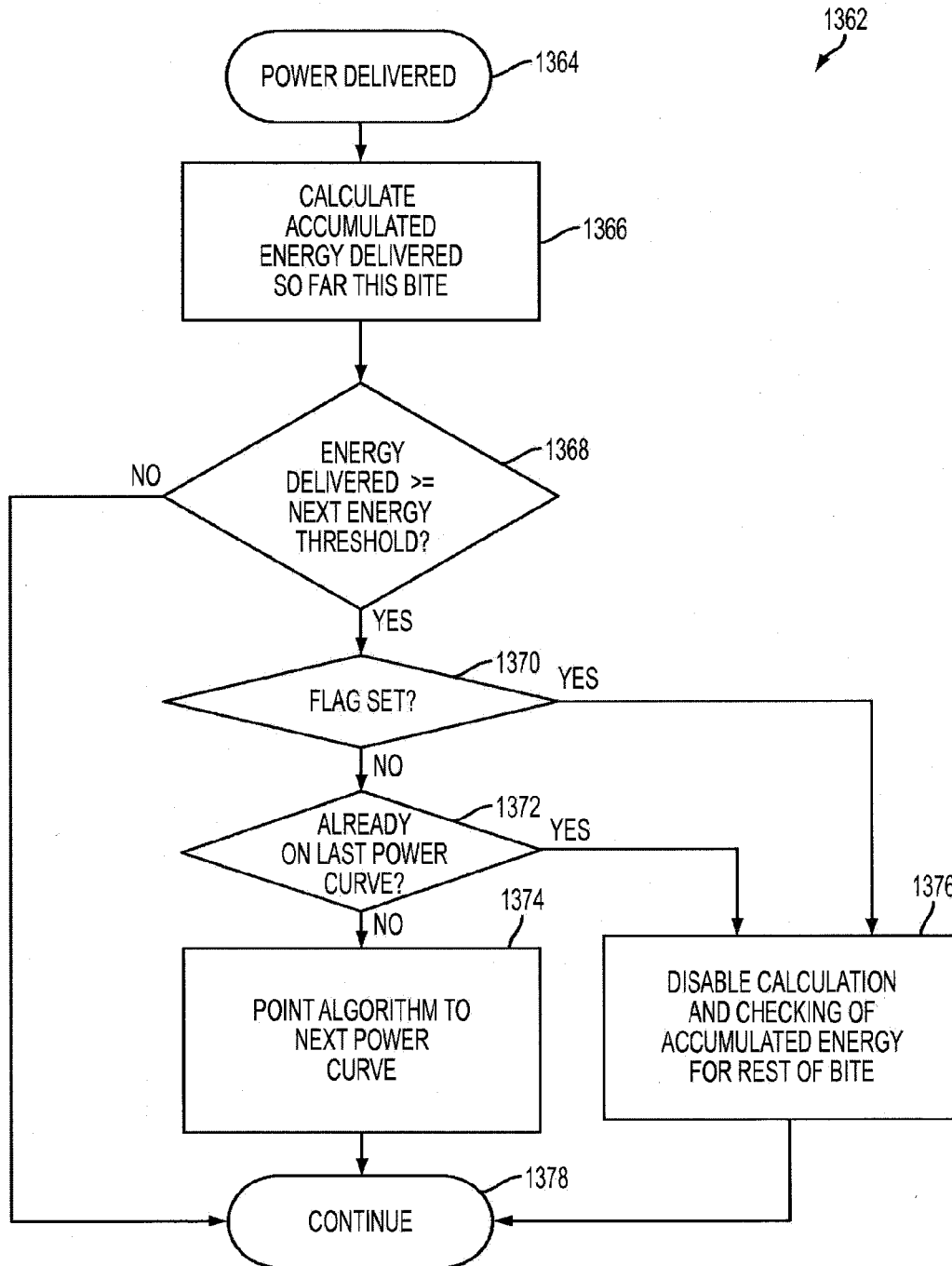

FIG. 73C

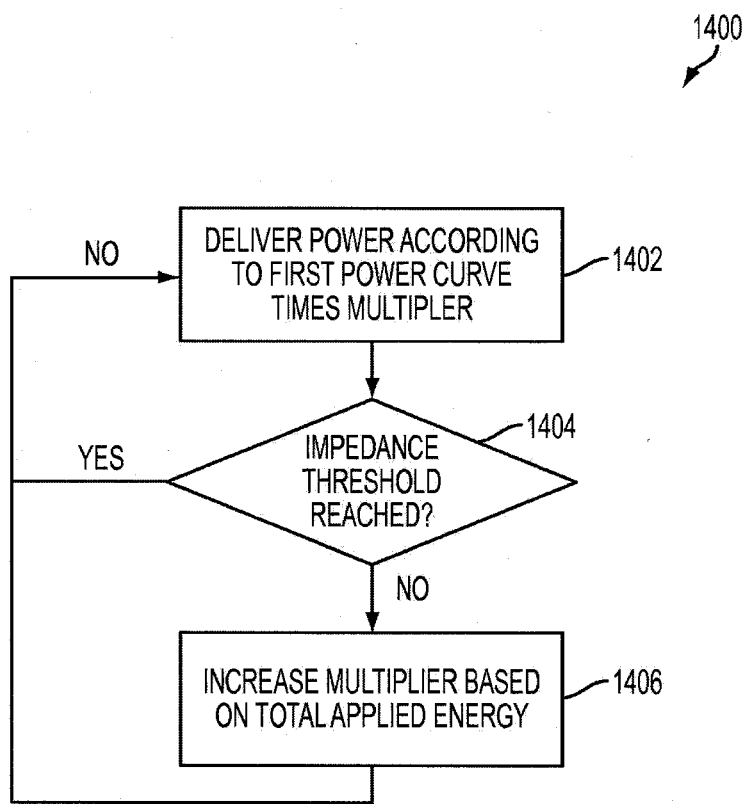

FIG. 74

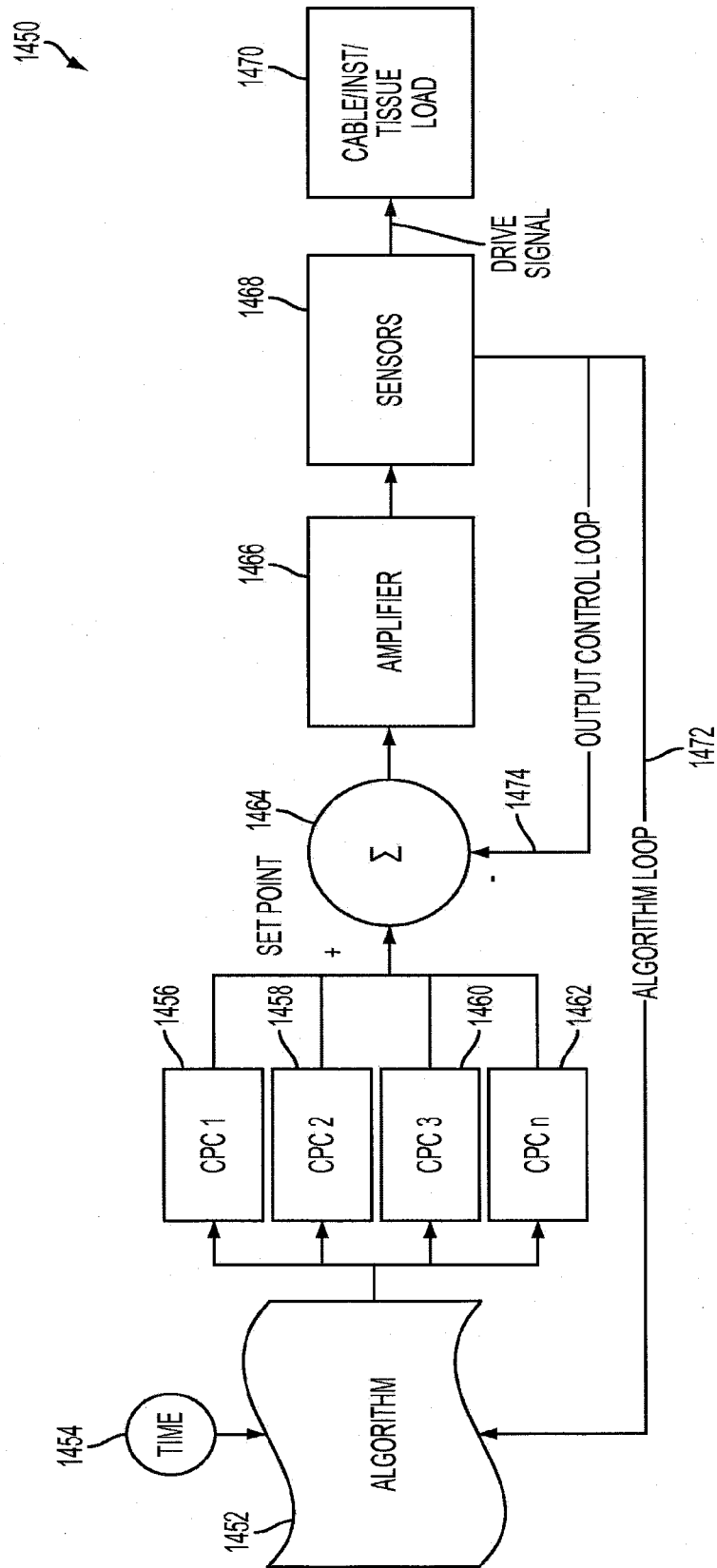

FIG. 75

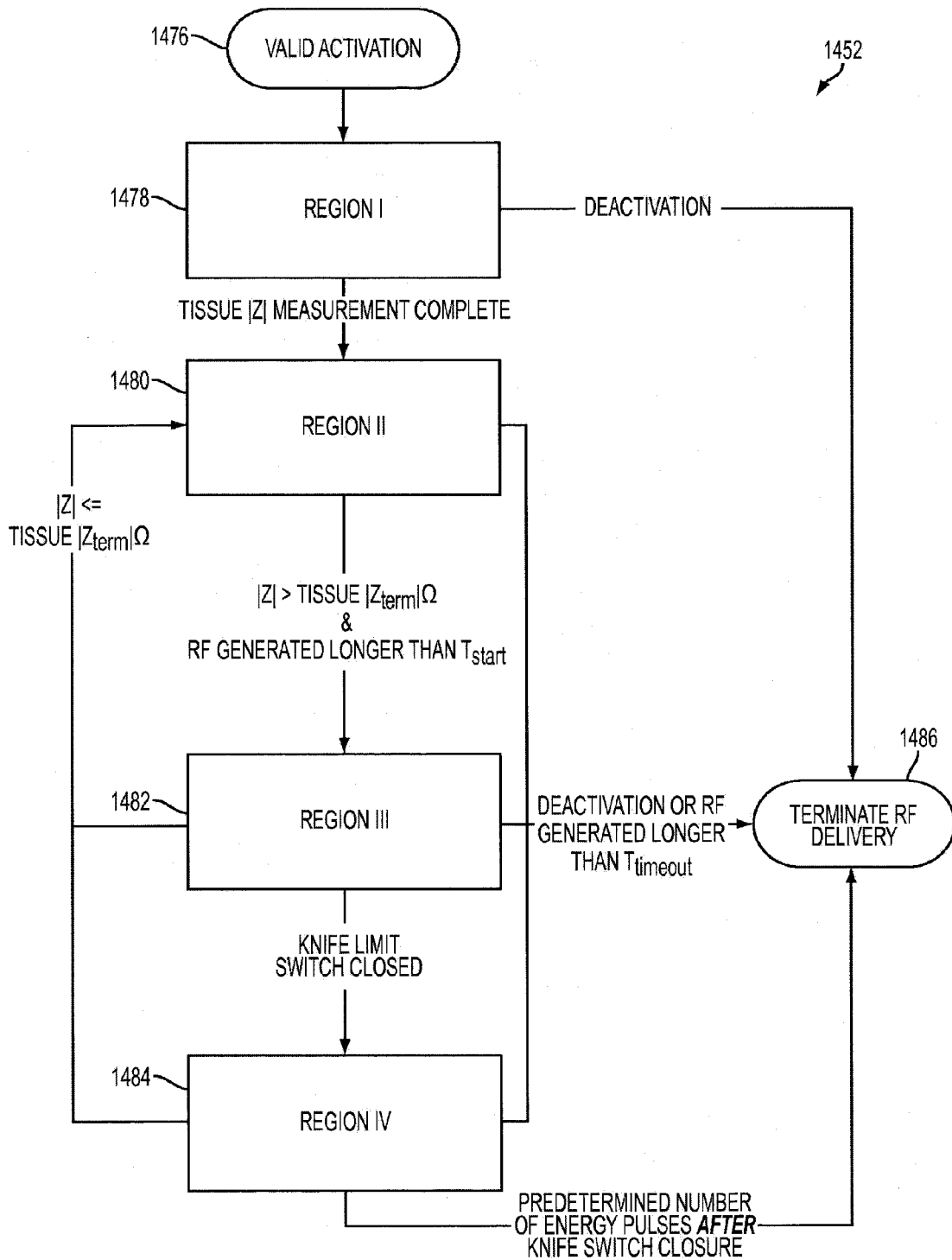

FIG. 76



1488

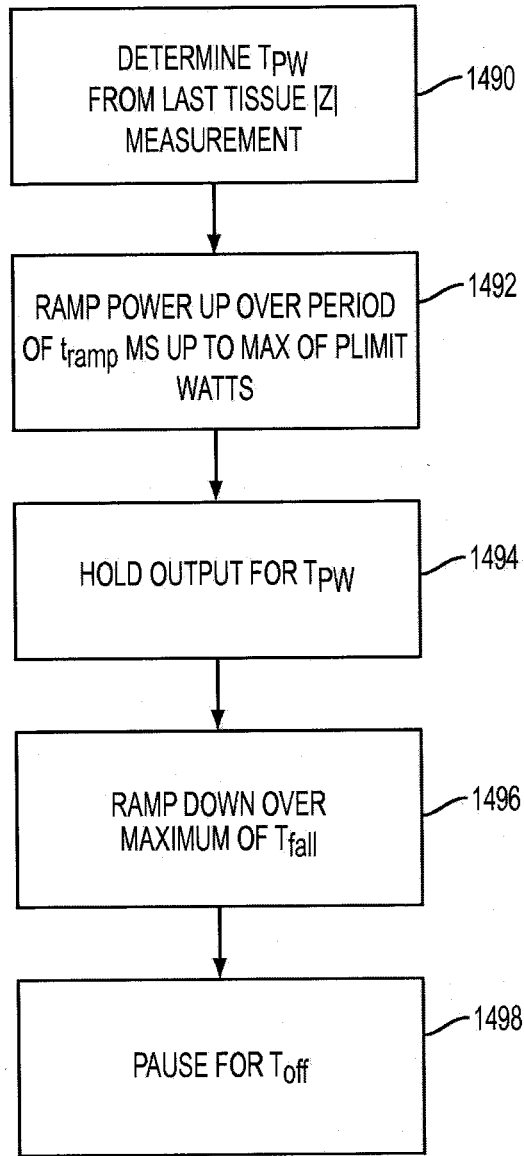

FIG. 77

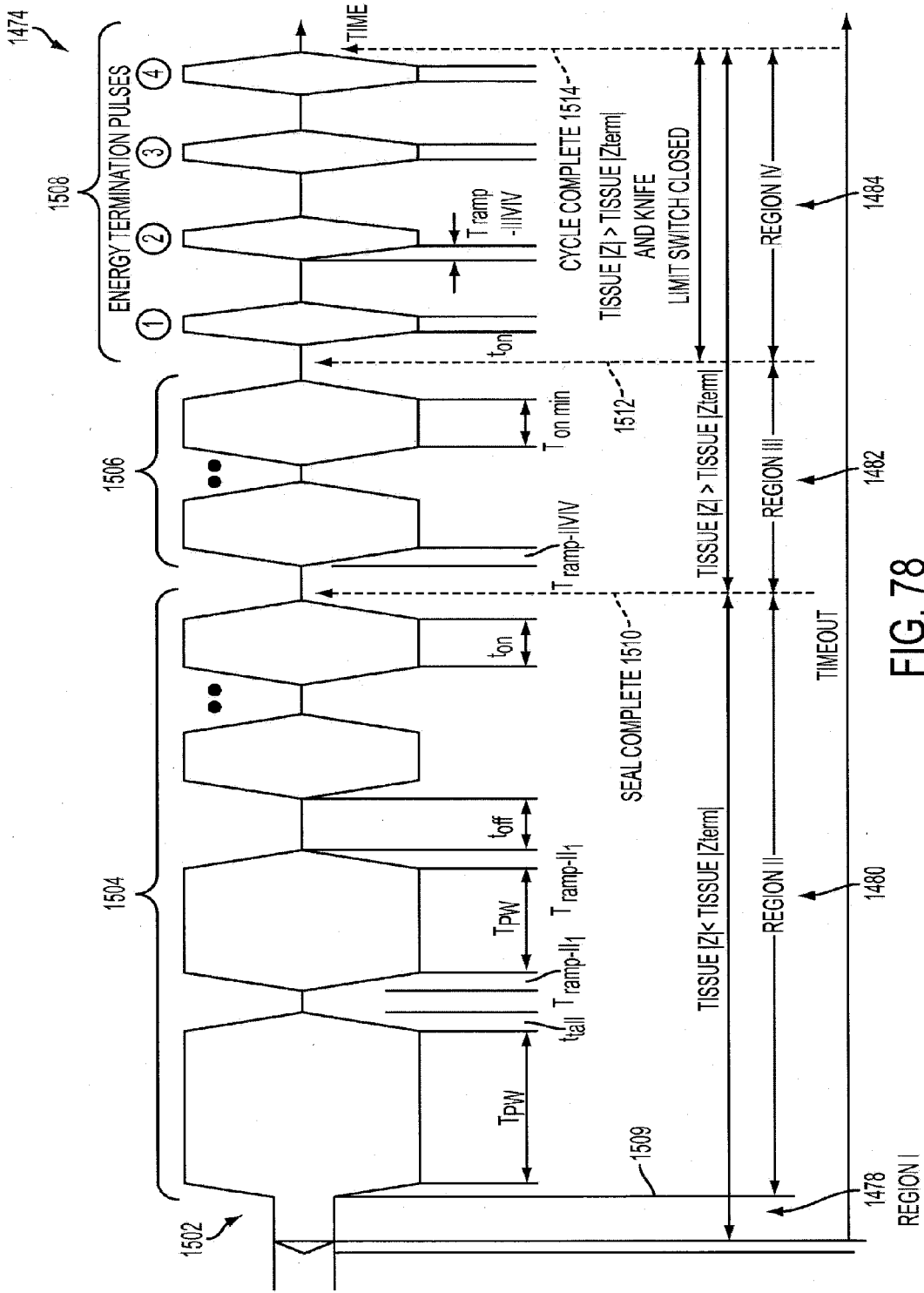

FIG. 78

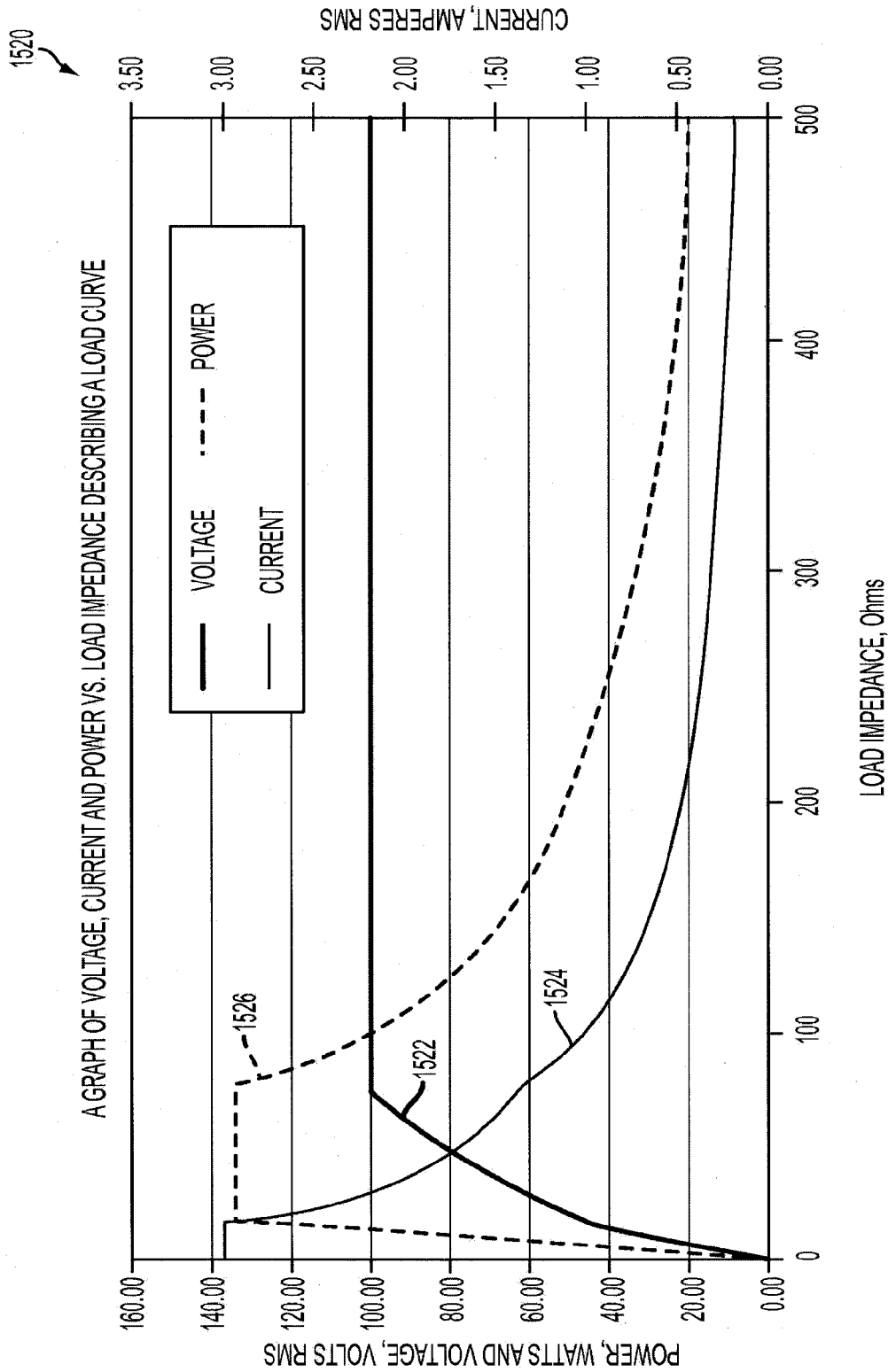

FIG. 79

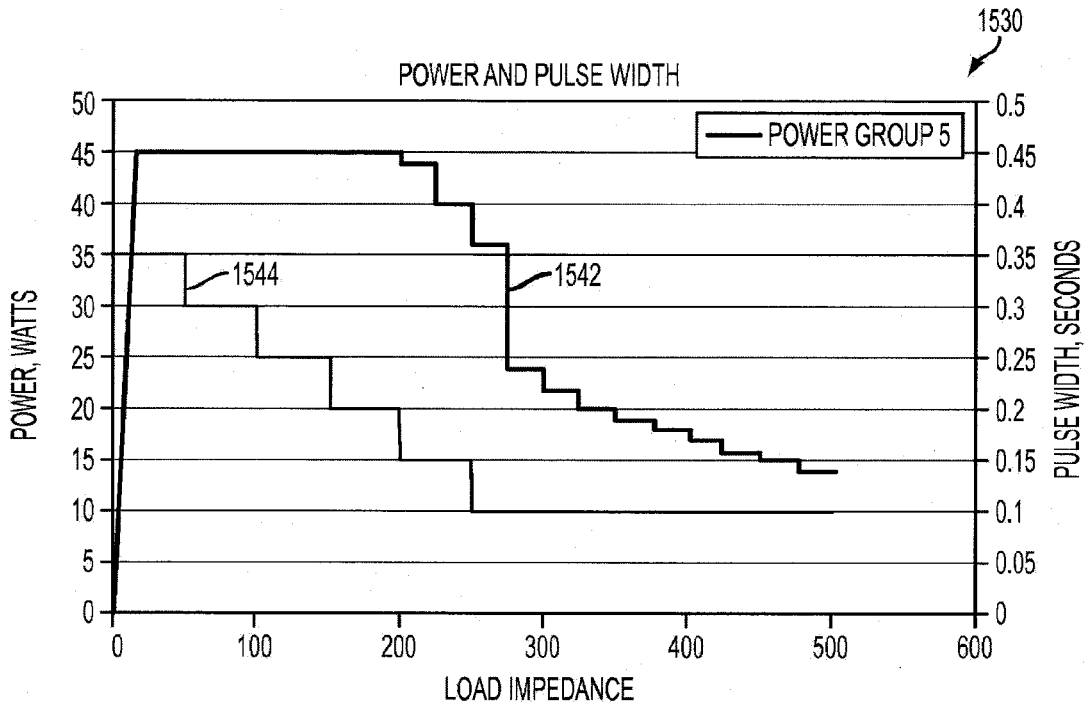

FIG. 80

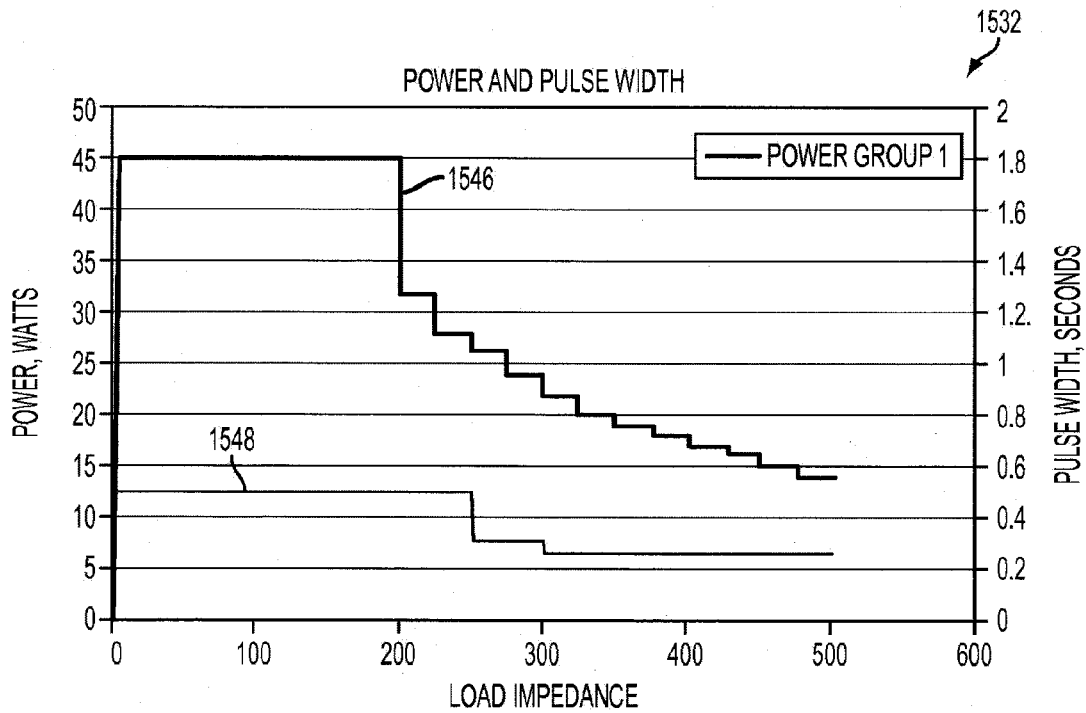

FIG. 81

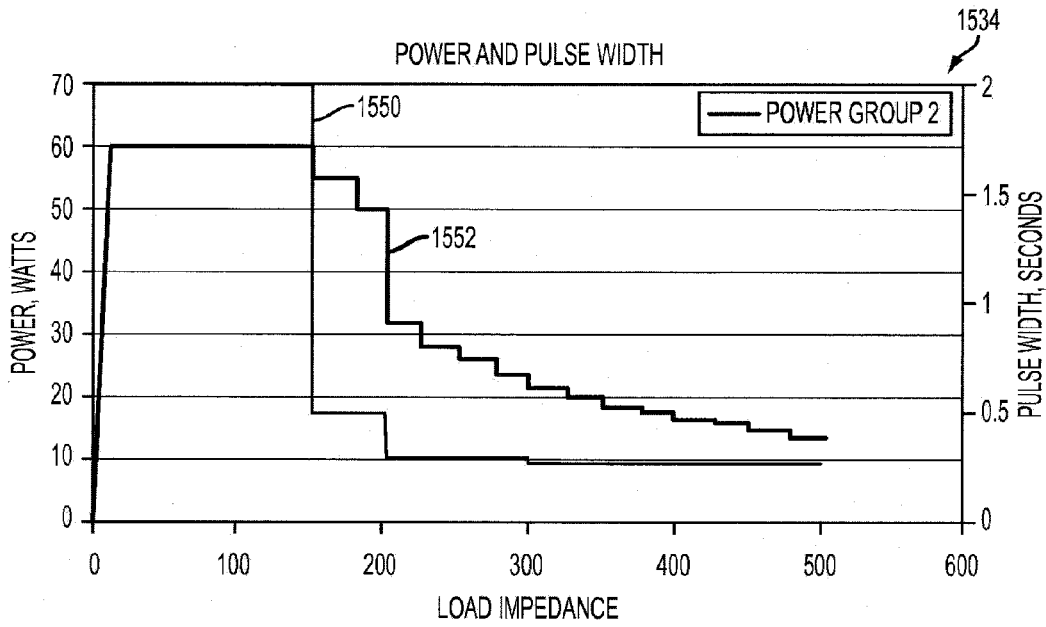

FIG. 82

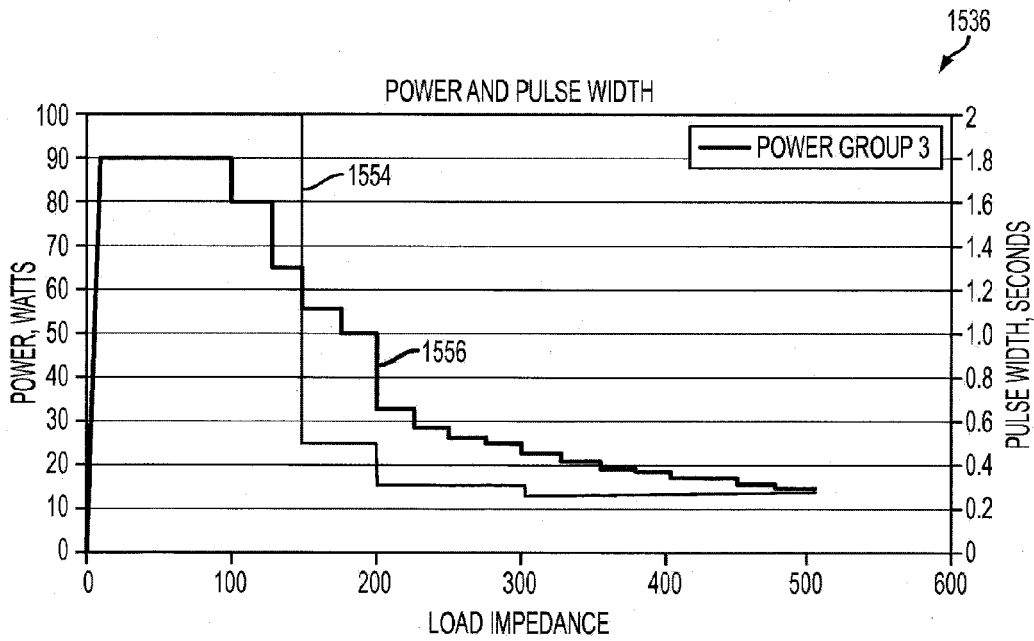

FIG. 83

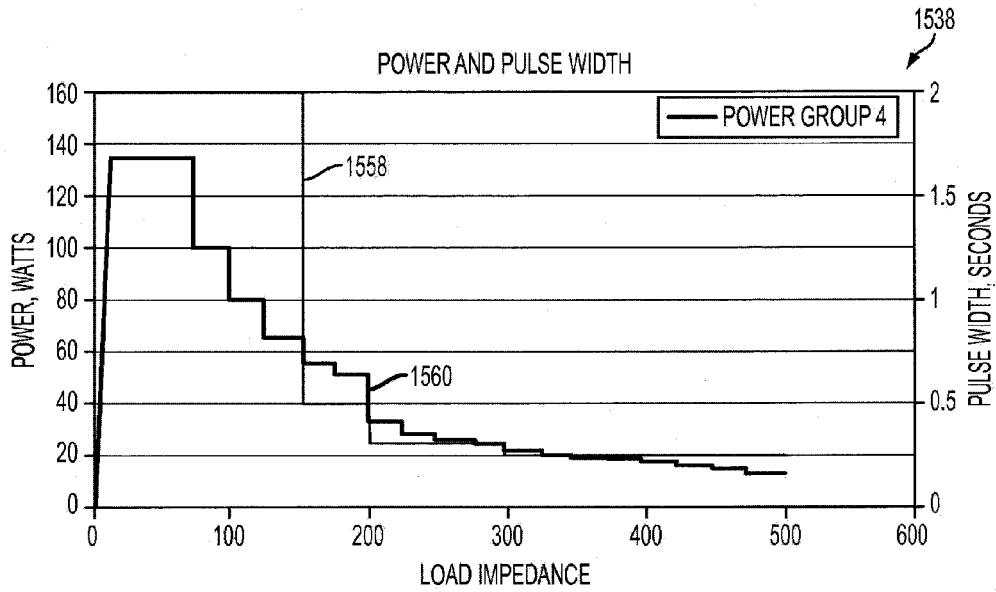

FIG. 84

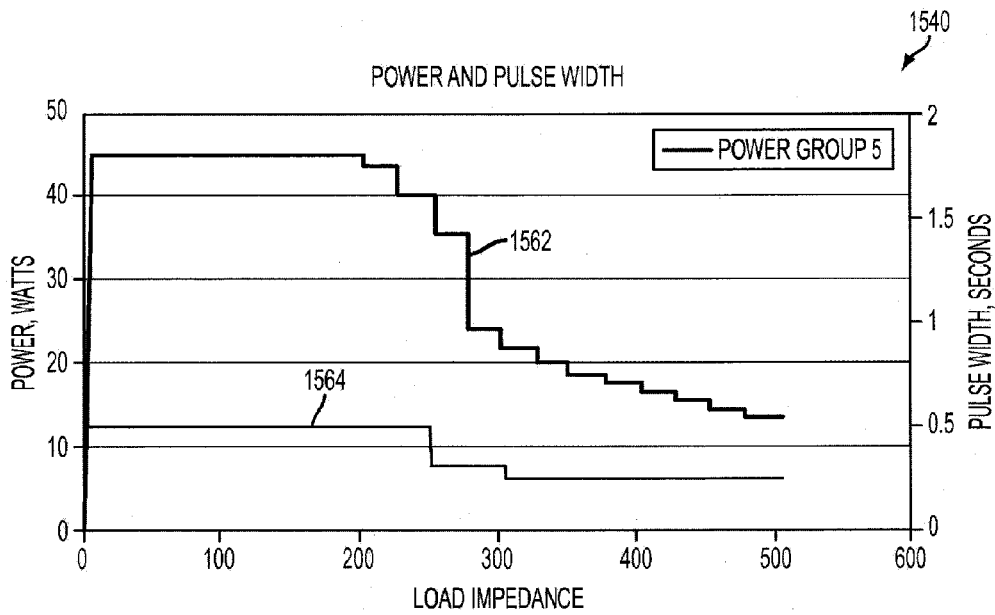

FIG. 85

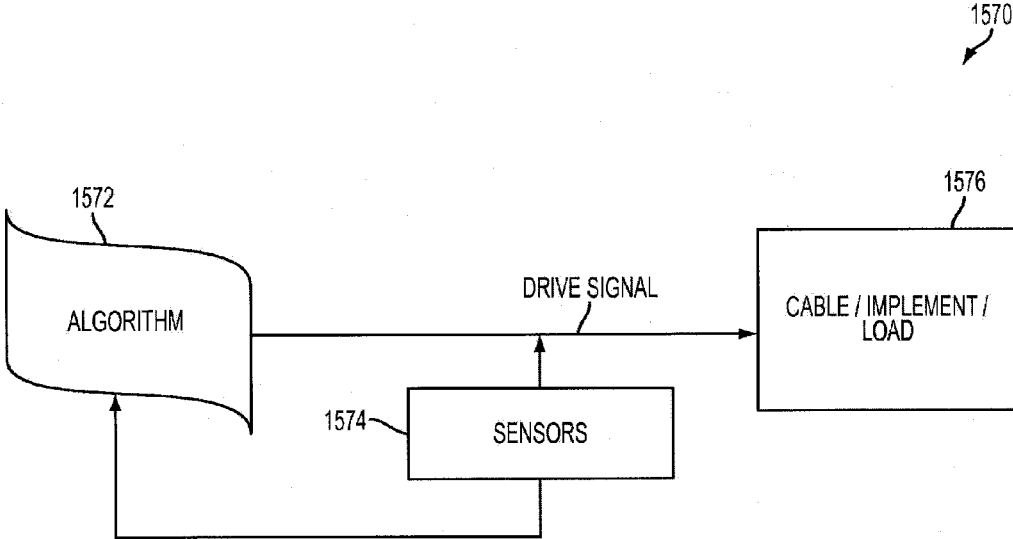

FIG. 86

## SURGICAL GENERATOR FOR ULTRASONIC AND ELECTROSURGICAL DEVICES

### CROSS REFERENCE TO RELATED APPLICATION

**[0001]** This application is a continuation of U.S. patent application Ser. No. 12/896,360, entitled SURGICAL GENERATOR FOR ULTRASONIC AND ELECTROSURGICAL DEVICES, U.S. Patent Application Publication No. 2011/0087256, filed on Oct. 1, 2010, which is incorporated herein by reference in its entirety, and claims the benefit under Title 35, United States Code §119(e), of U.S. Provisional Patent Application Ser. No. 61/250,217, filed Oct. 9, 2009 and entitled A DUAL BIPOLAR AND ULTRASONIC GENERATOR FOR ELECTRO-SURGICAL INSTRUMENTS, which is hereby incorporated by reference in its entirety.

**[0002]** The present application is related to the following, U.S. patent applications, which are incorporated herein by reference in their entirety:

**[0003]** (1) U.S. patent application Ser. No. 12/896,351, entitled DEVICES AND TECHNIQUES FOR CUTTING AND COAGULATING TISSUE, now U.S. Patent Application Publication No. 2011/0082486 A1, filed on Oct. 1, 2010;

**[0004]** (2) U.S. patent application Ser. No. 12/896,479, entitled SURGICAL GENERATOR FOR ULTRASONIC AND ELECTROSURGICAL DEVICES, now U.S. Pat. No. 8,956,349, filed on Oct. 1, 2010;

**[0005]** (3) U.S. patent application Ser. No. 12/896,345, entitled SURGICAL GENERATOR FOR ULTRASONIC AND ELECTROSURGICAL DEVICES, now U.S. Patent Application Publication No. 2011/0087212 A1, filed on Oct. 1, 2010;

**[0006]** (4) U.S. patent application Ser. No. 12/896,384, entitled SURGICAL GENERATOR FOR ULTRASONIC AND ELECTROSURGICAL DEVICES, now U.S. Pat. No. 8,951,248, filed on Oct. 1, 2010;

**[0007]** (5) U.S. patent application Ser. No. 12/896,467, entitled SURGICAL GENERATOR FOR ULTRASONIC AND ELECTROSURGICAL DEVICES, now U.S. Patent Application Publication No. 2011/0087215 A1, filed on Oct. 1, 2010;

**[0008]** (6) U.S. patent application Ser. No. 12/896,451, entitled SURGICAL GENERATOR FOR ULTRASONIC AND ELECTROSURGICAL DEVICES, now U.S. Patent Application Publication No. 2011/0087214 A1, filed on Oct. 1, 2010;

**[0009]** (7) U.S. patent application Ser. No. 12/896,470, entitled SURGICAL GENERATOR FOR ULTRASONIC AND ELECTROSURGICAL DEVICES, now U.S. Patent Application Publication No. 2011/0087217 A1, filed on Oct. 1, 2010;

**[0010]** (8) U.S. patent application Ser. No. 13/448,175, entitled SURGICAL GENERATOR FOR ULTRASONIC AND ELECTROSURGICAL DEVICES, now U.S. Patent Application Publication No. 2012/0265196, filed on Apr. 16, 2012; and

**[0011]** (9) U.S. patent application Ser. No. 13/251,766, entitled SURGICAL GENERATOR FOR ULTRASONIC AND ELECTROSURGICAL DEVICES, now U.S. Patent Application Publication No. 2012/0078139, filed on Oct. 3, 2011.

**[0012]** (10) U.S. patent application Ser. No. \_\_\_\_\_, entitled SURGICAL GENERATOR FOR ULTRASONIC AND ELECTROSURGICAL DEVICES, filed on Mar. 13, 2015; Attorney Docket No. END6673USCNT2/100558CON2.

### BACKGROUND

**[0013]** Various embodiments are directed to surgical devices, and generators for supplying energy to surgical devices, for use in open or minimally invasive surgical environments.

**[0014]** Ultrasonic surgical devices, such as ultrasonic scalpels, are finding increasingly widespread applications in surgical procedures by virtue of their unique performance characteristics. Depending upon specific device configurations and operational parameters, ultrasonic surgical devices can provide substantially simultaneous transection of tissue and homeostasis by coagulation, desirably minimizing patient trauma. An ultrasonic surgical device may comprise a handpiece containing an ultrasonic transducer, and an instrument coupled to the ultrasonic transducer having a distally-mounted end effector (e.g., a blade tip) to cut and seal tissue. In some cases, the instrument may be permanently affixed to the handpiece. In other cases, the instrument may be detachable from the handpiece, as in the case of a disposable instrument or an instrument that is interchangeable between different handpieces. The end effector transmits ultrasonic energy to tissue brought into contact with the end effector to realize cutting and sealing action. Ultrasonic surgical devices of this nature can be configured for open surgical use, laparoscopic, or endoscopic surgical procedures including robotic-assisted procedures.

**[0015]** Ultrasonic energy cuts and coagulates tissue using temperatures lower than those used in electro-surgical procedures and can be transmitted to the end effector by an ultrasonic generator in communication with the handpiece. Vibrating at high frequencies (e.g., 55,500 times per second), the ultrasonic blade denatures protein in the tissue to form a sticky coagulum. Pressure exerted on tissue by the blade surface collapses blood vessels and allows the coagulum to form a haemostatic seal. A surgeon can control the cutting speed and coagulation by the force applied to the tissue by the end effector, the time over which the force is applied and the selected excursion level of the end effector.

**[0016]** The ultrasonic transducer may be modeled as an equivalent circuit comprising a first branch having a static capacitance and a second “motional” branch having a serially connected inductance, resistance and capacitance that define the electromechanical properties of a resonator. Known ultrasonic generators may include a tuning inductor for tuning out the static capacitance at a resonant frequency so that substantially all of generator’s drive signal current flows into the motional branch. Accordingly, by using a tuning inductor, the generator’s drive signal current represents the motional branch current, and the generator is thus able to control its drive signal to maintain the ultrasonic transducer’s resonant frequency. The tuning inductor may also transform the phase impedance plot of the ultrasonic transducer to improve the generator’s frequency lock capabilities. However, the tuning inductor must be matched with the specific static capacitance of an ultrasonic transducer at the operational resonance frequency. In other words, a different ultrasonic transducer having a different static capacitance requires a different tuning inductor.



[0017] Additionally, in some ultrasonic generator architectures, the generator's drive signal exhibits asymmetrical harmonic distortion that complicates impedance magnitude and phase measurements. For example, the accuracy of impedance phase measurements may be reduced due to harmonic distortion in the current and voltage signals.

[0018] Moreover, electromagnetic interference in noisy environments decreases the ability of the generator to maintain lock on the ultrasonic transducer's resonant frequency, increasing the likelihood of invalid control algorithm inputs.

[0019] Electrosurgical devices for applying electrical energy to tissue in order to treat and/or destroy the tissue are also finding increasingly widespread applications in surgical procedures. An electrosurgical device may comprise a handpiece and an instrument having a distally-mounted end effector (e.g., one or more electrodes). The end effector can be positioned against the tissue such that electrical current is introduced into the tissue. Electrosurgical devices can be configured for bipolar or monopolar operation. During bipolar operation, current is introduced into and returned from the tissue by active and return electrodes, respectively, of the end effector. During monopolar operation, current is introduced into the tissue by an active electrode of the end effector and returned through a return electrode (e.g., a grounding pad) separately located on a patient's body. Heat generated by the current flow through the tissue may form haemostatic seals within the tissue and/or between tissues and thus may be particularly useful for sealing blood vessels, for example. The end effector of an electrosurgical device may also comprise a cutting member that is movable relative to the tissue and the electrodes to transect the tissue.

[0020] Electrical energy applied by an electrosurgical device can be transmitted to the instrument by a generator in communication with the handpiece. The electrical energy may be in the form of radio frequency ("RF") energy. RF energy is a form of electrical energy that may be in the frequency range of 300 kHz to 1 MHz. During its operation, an electrosurgical device can transmit low frequency RF energy through tissue, which causes ionic agitation, or friction, in effect resistive heating, thereby increasing the temperature of the tissue. Because a sharp boundary may be created between the affected tissue and the surrounding tissue, surgeons can operate with a high level of precision and control, without sacrificing un-targeted adjacent tissue. The low operating temperatures of RF energy may be useful for removing, shrinking, or sculpting soft tissue while simultaneously sealing blood vessels. RF energy may work particularly well on connective tissue, which is primarily comprised of collagen and shrinks when contacted by heat.

[0021] Due to their unique drive signal, sensing and feedback needs, ultrasonic and electrosurgical devices have generally required different generators. Additionally, in cases where the instrument is disposable or interchangeable with a handpiece, ultrasonic and electrosurgical generators are limited in their ability to recognize the particular instrument configuration being used and to optimize control and diagnostic processes accordingly. Moreover, capacitive coupling between the non-isolated and patient-isolated circuits of the generator, especially in cases where higher voltages and frequencies are used, may result in exposure of a patient to unacceptable levels of leakage current.

## SUMMARY

[0022] Various embodiments of a generator to communicate a drive signal to a surgical device are disclosed. In one embodiment, the generator may comprise a power amplifier to receive a time-varying drive signal waveform. The drive signal waveform may be generated by a digital-to-analog conversion of at least a portion of a plurality of drive signal waveform samples. An output of the power amplifier may be for generating a drive signal. The drive signal may comprise one of: a first drive signal to be communicated to an ultrasonic surgical device, a second drive signal to be communicated to an electrosurgical device. The generator may also comprise a sampling circuit to generate samples of current and voltage of the drive signal when the drive signal is communicated to the surgical device. Generation of the samples may be synchronized with the digital-to-analog conversion of the drive signal waveform samples such that, for each digital-to-analog conversion of a drive signal waveform sample, the sampling circuit generates a corresponding set of current and voltage samples. The generator may also comprise at least one device programmed to, for each drive signal waveform sample and corresponding set of current and voltage samples, store the current and voltage samples in a memory of the at least one device to associate the stored samples with the drive signal waveform sample. The at least one device may also be programmed to, when the drive signal comprises the first drive signal: determine a motional branch current sample of the ultrasonic surgical device based on the stored current and voltage samples, compare the motional branch current sample to a target sample selected from a plurality of target samples that define a target waveform, the target sample selected based on the drive signal waveform sample, determine an amplitude error between the target sample and the motional branch current sample, and modify the drive signal waveform sample such that an amplitude error determined between the target sample and a subsequent motional branch current sample based on current and voltage samples associated with the modified drive signal waveform sample is reduced.

[0023] In one embodiment, the generator may comprise a memory and a device coupled to the memory to receive for each of a plurality of drive signal waveform samples used to synthesize the drive signal, a corresponding set of current and voltage samples of the drive signal. For each drive signal waveform sample and corresponding set of current and voltage samples, the device may store the samples in a memory of the device to associate the stored samples with the drive signal waveform sample. Also, for each drive signal waveform sample and corresponding set of current and voltage samples, the device may, when the drive signal comprises a first drive signal to be communicated to an ultrasonic surgical device, determine a motional branch current sample of the ultrasonic surgical device based on the stored samples, compare the motional branch current sample to a target sample selected from a plurality of target samples that define a target waveform, the target sample selected based on the drive signal waveform sample, determine an amplitude error between the target sample and the motional branch current sample, and modify the drive signal waveform sample such that an amplitude error determined between the target sample and a subsequent motional branch current sample based on current and voltage samples associated with the modified drive signal waveform sample is reduced.

**[0024]** Embodiments of a method for determining motional branch current in an ultrasonic transducer of an ultrasonic surgical device over multiple frequencies of a transducer drive signal are also disclosed. In one embodiment, the method may comprise, at each of a plurality of frequencies of the transducer drive signal, oversampling a current and voltage of the transducer drive signal, receiving, by a processor, the current and voltage samples, and determining, by the processor, the motional branch current based on the current and voltage samples, a static capacitance of the ultrasonic transducer and the frequency of the transducer drive signal.

**[0025]** Embodiments of a method for controlling a waveform shape of a motional branch current in an ultrasonic transducer of a surgical device are also disclosed. In one embodiment, the method may comprise generating a transducer drive signal by selectively recalling, using a direct digital synthesis (DDS) algorithm, drive signal waveform samples stored in a look-up table (LUT), generating samples of current and voltage of the transducer drive signal when the transducer drive signal is communicated to the surgical device, determining samples of the motional branch current based on the current and voltage samples, a static capacitance of the ultrasonic transducer and a frequency of the transducer drive signal, comparing each sample of the motional branch current to a respective target sample of a target waveform to determine an error amplitude, and modifying the drive signal waveform samples stored in the LUT such that an amplitude error between subsequent samples of the motional branch current and respective target samples is reduced.

**[0026]** In accordance with various embodiments, a surgical generator for providing a drive signal to a surgical device may comprise a first transformer and a second transformer. The first transformer may comprise a first primary winding and a first secondary winding. The second transformer may comprise a second primary winding and a second secondary winding. The surgical generator may further comprise a generator circuit to generate the drive signal. The generator circuit may be electrically coupled to the first primary winding to provide the drive signal across the first primary winding. The surgical generator may also comprise a patient-side circuit electrically isolated from the generator circuit. The patient-side circuit may be electrically coupled to the first secondary winding. Further, the patient-side circuit may comprise first and second output lines to provide the drive signal to the surgical device. In addition, the surgical generator may comprise a capacitor. The capacitor and the second secondary winding may be electrically coupled in series between the first output line and ground.

**[0027]** Also, in accordance with various embodiments, a surgical generator for providing a drive signal to a surgical device may comprise a first transformer, a patient-side circuit, and a capacitor. The first transformer may comprise a primary winding, a first secondary winding, and a second secondary winding. A polarity of the first secondary winding relative to the primary winding may be opposite the polarity of the second secondary winding. The generator circuit may generate the drive signal and may be electrically coupled to the first primary winding to provide the drive signal across the first primary winding. The patient-side circuit may be electrically isolated from the generator circuit and may be electrically coupled to the first secondary winding. Also, the patient-side circuit may comprise first and second output

lines to provide the drive signal to the surgical device. The capacitor and second secondary winding may be electrically coupled in series between the first output line and ground.

**[0028]** Additionally, in accordance with various embodiments, a surgical generator for providing a drive signal to a surgical device may comprise, a first transformer, a generator circuit, a patient-side circuit and a capacitor. The first transformer may comprise a primary winding and a secondary winding. The generator circuit may generate the drive signal and may be electrically coupled to the first primary winding to provide the drive signal across the first primary winding. The patient-side circuit may be electrically isolated from the generator circuit and may be electrically coupled to the secondary winding. Further, the patient-side circuit may comprise first and second output lines to provide the drive signal to the surgical device. The capacitor may be electrically coupled to the primary winding and to the first output line.

**[0029]** In accordance with various embodiments, a surgical generator for providing a drive signal to a surgical device may comprise a first transformer, a generator circuit, a patient-side circuit, as well as first, second and third capacitors. The first transformer may comprise a primary winding and a secondary winding. The generator circuit may generate the drive signal and may be electrically coupled to the first primary winding to provide the drive signal across the first primary winding. The patient-side circuit may be electrically isolated from the generator circuit and may be electrically coupled to the secondary winding. Further, the patient-side circuit may comprise first and second output lines to provide the drive signal to the surgical device. A first electrode of the first capacitor may be electrically coupled to the primary winding. A first electrode of the second capacitor may be electrically coupled to the first output line and a second electrode of the second capacitor may be electrically coupled to a second electrode of the first capacitor. A first electrode of the third capacitor may be electrically coupled to the second electrode of the first capacitor and the second electrode of the second capacitor. A second electrode of the third capacitor may be electrically coupled to ground.

**[0030]** Various embodiments of surgical device control circuits are also disclosed. In one embodiment, the control circuit may comprise a first circuit portion comprising at least one first switch. The first circuit portion may communicate with a surgical generator over a conductor pair. The control circuit may also comprise a second circuit portion comprising a data circuit element. The data circuit element may be disposed in an instrument of the surgical device and transmit or receive data. The data circuit element may implement data communications with the surgical generator over at least one conductor of the conductor pair.

**[0031]** In one embodiment, the control circuit may comprise a first circuit portion comprising at least one first switch. The first circuit portion may communicate with a surgical generator over a conductor pair. The control circuit may also comprise a second circuit portion comprising a data circuit element. The data circuit element may be disposed in an instrument of the surgical device and transmit or receive data. The data circuit element may implement data communications with the surgical generator over at least one conductor of the conductor pair. The first circuit portion may receive a first interrogation signal transmitted from the surgical generator in a first frequency band. The data circuit element may communicate with the surgical

generator using an amplitude-modulated communication protocol transmitted in a second frequency band. The second frequency band may be higher than the first frequency band.

**[0032]** In one embodiment, the control circuit may comprise a first circuit portion comprising at least one first switch. The first circuit portion may receive a first interrogation signal transmitted from a surgical generator over a conductor pair. The control circuit may also comprise a second circuit portion comprising at least one of a resistive element and an inductive element disposed in an instrument of the device. The second circuit portion may receive a second interrogation signal transmitted from the surgical generator over the conductor pair. The second circuit portion may be frequency-band separated from the first circuit portion. A characteristic of the first interrogation signal, when received through the first circuit portion, may be indicative of a state of the at least one first switch. A characteristic of the second interrogation signal, when received through the second circuit portion, may uniquely identify the instrument of the device.

**[0033]** In one embodiment, the control circuit may comprise a first circuit portion comprising a first switch network and a second switch network. The first switch network may comprise at least one first switch, and the second switch network may comprise at least one second switch. The first circuit portion may communicate with a surgical generator over a conductor pair. The control circuit may also comprise a second circuit portion comprising a data circuit element. The data circuit element may be disposed in an instrument of the surgical device and may transmit or receive data. The data circuit element may be in data communication with the surgical generator over at least one conductor of the conductor pair.

**[0034]** In accordance with various embodiments, a surgical generator for providing a drive signal to a surgical device may comprise a surgical generator body having an aperture. The surgical generator may also comprise a receptacle assembly positioned in the aperture. The receptacle assembly may comprise a receptacle body and a flange having an inner wall and an outer wall. The inner wall may be comprised of at least one curved section and at least one linear section. The inner wall may define a cavity. A central protruding portion may be positioned in the cavity and may comprise a plurality of sockets and a magnet. An outer periphery of the central protruding portion may comprise at least one curved section and at least one linear section.

**[0035]** In accordance with various embodiments, a surgical instrument may comprise an electrical connector assembly. The electrical connector assembly may comprise a flange defining a central cavity and a magnetically compatible pin extending into the central cavity. The electrical connector assembly may comprise a circuit board and a plurality of electrically conductive pins coupled to the circuit board. Each of the plurality of electrically conductive pins may extend into the central cavity. The electrical connector assembly may further comprise a strain relief member and a boot.

**[0036]** In accordance with various embodiments, a surgical instrument system may comprise a surgical generator comprising a receptacle assembly. The receptacle assembly may comprise at least one curved section and at least one linear portion. The surgical instrument system may comprise a surgical instrument comprising a connector assembly and an adapter assembly operatively coupled to the receptacle

assembly and the connector assembly. The adapter assembly may comprise a distal portion contacting the receptacle assembly. The distal portion may comprise a flange with the flange having at least one curved section and at least one linear portion. The adapter assembly may comprise a proximal portion contacting the connector assembly. The proximal portion may define a cavity dimensioned to receive at least a portion of the connector assembly. The adapter assembly may further comprise a circuit board.

**[0037]** In accordance with various embodiments, methods may be utilized (e.g., in conjunction with surgical instruments) to accomplish various surgical objectives. For example, methods to control electrical power provided to tissue via first and second electrodes may comprise providing a drive signal to the tissue via the first and second electrodes and modulating a power provided to the tissue via the drive signal based on a sensed tissue impedance according to a first power curve. The first power curve may define, for each of a plurality of potential sensed tissue impedances, a first corresponding power. The methods may also comprise monitoring a total energy provided to the tissue via the first and second electrodes. When the total energy reaches a first energy threshold, the methods may comprise determining whether an impedance of the tissue has reached a first impedance threshold. The methods may further comprise, conditioned upon the impedance of the tissue failing to reach the first impedance threshold, modulating the power provided to the tissue via the drive signal based on the sensed tissue impedance according to a second power curve. The second power curve may define, for each of the plurality of potential sensed tissue impedances, a second corresponding power.

**[0038]** In accordance with various embodiments, methods for controlling electrical power provided to tissue via first and second electrodes may comprise providing a drive signal to the tissue via the first and second electrodes and determining a power to be provided to the tissue. The determining may comprise receiving an indication of a sensed tissue impedance; determining a first corresponding power for the sensed tissue impedance according to a power curve; and multiplying the corresponding power by a multiplier. The power curve may define a corresponding power for each of a plurality of potential sensed tissue impedances. The methods may further comprise modulating the drive signal to provide the determined power to the tissue and, conditioned upon the impedance of the tissue failing to reach a first impedance threshold, increasing the multiplier as a function of the total energy provided to the tissue.

**[0039]** In accordance with various embodiments, methods for controlling electrical power provided to tissue via first and second electrodes may comprise providing a drive signal to the tissue via the first and second electrodes and determining a power to be provided to the tissue. The determining may comprise receiving an indication of a sensed tissue impedance; determining a first corresponding power for the sensed tissue impedance according to a power curve; and multiplying the corresponding power by a first multiplier to find a determined power. The power curve may define a corresponding power for each of a plurality of potential sensed tissue impedances. The methods may further comprise modulating the drive signal to provide the determined power to the tissue and monitoring a total energy provided to the tissue via the first and second electrodes. In addition, the methods may comprise, when the total energy

reaches a first energy threshold, determining whether the impedance of the tissue has reached a first impedance threshold; and, conditioned upon the impedance of the tissue not reaching the first impedance threshold, increasing the first multiplier by a first amount.

**[0040]** In accordance with various embodiments, methods for controlling electrical power provided to tissue via a surgical device may comprise providing a drive signal to a surgical device; receiving an indication of an impedance of the tissue; calculating a rate of increase of the impedance of the tissue; and modulating the drive signal to hold the rate of increase of the impedance greater than or equal to a predetermined constant.

**[0041]** In accordance with various embodiments, methods for controlling electrical power provided to tissue via a surgical device may comprise providing a drive signal. A power of the drive signal may be proportional to a power provided to the tissue via the surgical device. The methods may also comprise periodically receiving indications of an impedance of the tissue and applying a first composite power curve to the tissue. Applying the first composite power curve to the tissue may comprise modulating a first predetermined number of first composite power curve pulses on the drive signal; and for each of the first composite power curve pulses, determining a pulse power and a pulse width according to a first function of the impedance of the tissue. The methods may also comprise applying a second composite power curve to the tissue. Applying the second composite power curve to the tissue may comprise modulating at least one second composite power curve pulse on the drive signal; and for each of the at least one second composite power curve pulses, determining a pulse power and a pulse width according to a second function of the impedance of the tissue.

#### FIGURES

**[0042]** The novel features of the various embodiments are set forth with particularity in the appended claims. The described embodiments, however, both as to organization and methods of operation, may be best understood by reference to the following description, taken in conjunction with the accompanying drawings in which:

**[0043]** FIG. 1 illustrates one embodiment of a surgical system comprising a generator and various surgical instruments usable therewith;

**[0044]** FIG. 2 illustrates one embodiment of an example ultrasonic device that may be used for transection and/or sealing;

**[0045]** FIG. 3 illustrates one embodiment of the end effector of the example ultrasonic device of FIG. 2.

**[0046]** FIG. 4 illustrates one embodiment of an example electrosurgical device that may also be used for transection and sealing;

**[0047]** FIGS. 5, 6 and 7 illustrate one embodiment of the end effector shown in FIG. 4;

**[0048]** FIG. 8 is a diagram of the surgical system of FIG. 1;

**[0049]** FIG. 9 is a model illustrating motional branch current in one embodiment;

**[0050]** FIG. 10 is a structural view of a generator architecture in one embodiment;

**[0051]** FIGS. 11A-11C are functional views of a generator architecture in one embodiment;

**[0052]** FIG. 12 illustrates a controller for monitoring input devices and controlling output devices in one embodiment;

**[0053]** FIGS. 13A and 13B illustrate structural and functional aspects of one embodiment of the generator;

**[0054]** FIGS. 14-32 and 33A-33C illustrate embodiments of control circuits;

**[0055]** FIGS. 33D-33I illustrate embodiments of cabling and adaptor configurations for connecting various generators and various surgical instruments;

**[0056]** FIG. 34 illustrates one embodiment of a circuit for active cancellation of leakage current.

**[0057]** FIG. 35 illustrates one embodiment of a circuit that may be implemented by the generator of FIG. 1 to provide active cancellation of leakage current;

**[0058]** FIG. 36 illustrates an alternative embodiment of a circuit that may be implemented by the generator of FIG. 1 to provide active cancellation of leakage current;

**[0059]** FIG. 37 illustrates an alternative embodiment of a circuit that may be implemented by the generator of FIG. 1 to provide active cancellation of leakage current;

**[0060]** FIG. 38 illustrates yet another embodiment of a circuit that may be implemented by the generator of FIG. 1 to provide active cancellation of leakage current;

**[0061]** FIG. 39 illustrates an embodiment of a circuit that may be implemented by the generator of FIG. 1 to provide cancellation of leakage current;

**[0062]** FIG. 40 illustrates another embodiment of a circuit that may be implemented by the generator of FIG. 1 to provide cancellation of leakage current;

**[0063]** FIG. 41 illustrates a receptacle and connector interface in one embodiment;

**[0064]** FIG. 42 is an exploded side view of the receptacle assembly in one embodiment;

**[0065]** FIG. 43 is an exploded side view of the connector assembly in one embodiment;

**[0066]** FIG. 44 is a perspective view of the receptacle assembly shown in FIG. 41;

**[0067]** FIG. 45 is an exploded perspective view of the receptacle assembly in one embodiment;

**[0068]** FIG. 46 is a front elevation view of the receptacle assembly in one embodiment;

**[0069]** FIG. 47 is a side elevation view of the receptacle assembly in one embodiment;

**[0070]** FIG. 48 is an enlarged view of a socket in one embodiment;

**[0071]** FIG. 49 is a perspective view of the connector assembly in one embodiment;

**[0072]** FIG. 50 is an exploded perspective view of the connector assembly in one embodiment;

**[0073]** FIG. 51 is a side elevation view of a connector body in one embodiment;

**[0074]** FIG. 52 is perspective view of the distal end of a connector body in one embodiment;

**[0075]** FIG. 53 is perspective view of the proximal end of a connector body in one embodiment;

**[0076]** FIG. 54 illustrates a ferrous pin in one embodiment;

**[0077]** FIG. 55 illustrates electrically conductive pins and a circuit board in one embodiment;

**[0078]** FIG. 56 illustrates a strain relief member in one embodiment;

**[0079]** FIG. 57 illustrates a boot in one embodiment;

**[0080]** FIG. 58 illustrates two adaptor assemblies in accordance with various non-limiting embodiments;

[0081] FIG. 59 illustrates a surgical generator in one embodiment;

[0082] FIG. 60 illustrates a connector assembly connected to an adaptor assembly in one embodiment;

[0083] FIG. 61 illustrates an adaptor assembly inserted into a receptacle assembly of a surgical generator in one embodiment;

[0084] FIG. 62 illustrates a connector assembly connected to an adaptor assembly in one embodiment;

[0085] FIG. 63 illustrates a perspective view of a back panel of a generator in one embodiment;

[0086] FIG. 64 illustrates a back panel of a generator in one embodiment;

[0087] FIGS. 65 and 66 illustrate different portions of a back panel of a generator in one embodiment;

[0088] FIG. 67 illustrates a neural network for controlling a generator in one embodiment;

[0089] FIG. 68 illustrates measured temperature versus estimated temperature output by a surgical instrument controlled by a generator in one embodiment;

[0090] FIG. 69 illustrates one embodiment of a chart showing example power curves;

[0091] FIG. 70 illustrates one embodiment of a process flow for applying one or more power curves to a tissue bite;

[0092] FIG. 71 illustrates one embodiment of a chart showing example power curves that may be used in conjunction with the process flow of FIG. 70;

[0093] FIG. 72 illustrates one embodiment of a chart showing example common shape power curves that may be used in conjunction with the process flow of FIG. 70;

[0094] FIG. 73A illustrates one embodiment of a routine that may be performed by a digital device of the generator of FIG. 1 to act upon a new tissue bite;

[0095] FIG. 73B illustrates one embodiment of a routine that may be performed by a digital device of the generator of FIG. 1 to monitor tissue impedance;

[0096] FIG. 73C illustrates one embodiment of a routine that may be performed by a digital device of the generator of FIG. 1 to provide one or more power curves to a tissue bite;

[0097] FIG. 74 illustrates one embodiment of a process flow for applying one or more power curves to a tissue bite;

[0098] FIG. 75 illustrates one embodiment of a block diagram describing the selection and application of composite load curves by the generator of FIG. 1;

[0099] FIG. 76 illustrates a process flow illustrating one embodiment of the algorithm of FIG. 75, as implemented by the generator of FIG. 1;

[0100] FIG. 77 illustrates one embodiment of a process flow for generating a first composite load curve pulse;

[0101] FIG. 78 illustrates one embodiment of a pulse timing diagram illustrating an example application of the algorithm of FIG. 76 by the generator of FIG. 1;

[0102] FIG. 79 illustrates a graphical representation of drive signal voltage, current and power according to an example composite load curve;

[0103] FIGS. 80-85 illustrate a graphical representations of example composite load curves; and

[0104] FIG. 86 illustrates one embodiment of a block diagram describing the application of an algorithm for maintaining a constant tissue impedance rate of change.

## DESCRIPTION

[0105] Before explaining various embodiments of surgical devices and generators in detail, it should be noted that the illustrative embodiments are not limited in application or use to the details of construction and arrangement of parts illustrated in the accompanying drawings and description. The illustrative embodiments may be implemented or incorporated in other embodiments, variations and modifications, and may be practiced or carried out in various ways. Further, unless otherwise indicated, the terms and expressions employed herein have been chosen for the purpose of describing the illustrative embodiments for the convenience of the reader and are not for the purpose of limitation thereof. Also, it will be appreciated that one or more of the following-described embodiments, expressions of embodiments and/or examples, can be combined with any one or more of the other following-described embodiments, expressions of embodiments and/or examples.

[0106] Various embodiments are directed to improved ultrasonic surgical devices, electrosurgical devices and generators for use therewith. Embodiments of the ultrasonic surgical devices can be configured for transecting and/or coagulating tissue during surgical procedures, for example. Embodiments of the electrosurgical devices can be configured for transecting, coagulating, scaling, welding and/or desiccating tissue during surgical procedures, for example. [0107] Embodiments of the generator utilize high-speed analog-to-digital sampling (e.g., approximately 200x oversampling, depending on frequency) of the generator drive signal current and voltage, along with digital signal processing, to provide a number of advantages and benefits over known generator architectures. In one embodiment, for example, based on current and voltage feedback data, a value of the ultrasonic transducer static capacitance, and a value of the drive signal frequency, the generator may determine the motional branch current of an ultrasonic transducer. This provides the benefit of a virtually tuned system, and simulates the presence of a system that is tuned or resonant with any value of the static capacitance (e.g.,  $C_0$  in FIG. 9) at any frequency. Accordingly, control of the motional branch current may be realized by tuning out the effects of the static capacitance without the need for a tuning inductor. Additionally, the elimination of the tuning inductor may not degrade the generator's frequency lock capabilities, as frequency lock can be realized by suitably processing the current and voltage feedback data.

[0108] High-speed analog-to-digital sampling of the generator drive signal current and voltage, along with digital signal processing, may also enable precise digital filtering of the samples. For example, embodiments of the generator may utilize a low-pass digital filter (e.g., a finite impulse response (FIR) filter) that rolls off between a fundamental drive signal frequency and a second-order harmonic to reduce the asymmetrical harmonic distortion and EMI-induced noise in current and voltage feedback samples. The filtered current and voltage feedback samples represent substantially the fundamental drive signal frequency, thus enabling a more accurate impedance phase measurement with respect to the fundamental drive signal frequency and an improvement in the generator's ability to maintain resonant frequency lock. The accuracy of the impedance phase measurement may be further enhanced by averaging falling edge and rising edge phase measurements, and by regulating the measured impedance phase to 0°.

[0109] Various embodiments of the generator may also utilize the high-speed analog-to-digital sampling of the generator drive signal current and voltage, along with digital signal processing, to determine real power consumption and other quantities with a high degree of precision. This may allow the generator to implement a number of useful algorithms, such as, for example, controlling the amount of power delivered to tissue as the impedance of the tissue changes and controlling the power delivery to maintain a constant rate of tissue impedance increase.

[0110] Various embodiments of the generator may have a wide frequency range and increased output power necessary to drive both ultrasonic surgical devices and electrosurgical devices. The lower voltage, higher current demand of electrosurgical devices may be met by a dedicated tap on a wideband power transformer, thereby eliminating the need for a separate power amplifier and output transformer. Moreover, sensing and feedback circuits of the generator may support a large dynamic range that addresses the needs of both ultrasonic and electrosurgical applications with minimal distortion.

[0111] Various embodiments may provide a simple, economical means for the generator to read from, and optionally write to, data circuit (e.g., a single-wire bus device, such as a 1-Wire® protocol EEPROM) disposed in an instrument attached to the handpiece using existing multi-conductor generator/handpiece cables. In this way, the generator is able to retrieve and process instrument-specific data from an instrument attached to the handpiece. This may enable the generator to provide better control and improved diagnostics and error detection. Additionally, the ability of the generator to write data to the instrument makes possible new functionality in terms of, for example, tracking instrument usage and capturing operational data. Moreover, the use of frequency band permits the backward compatibility of instruments containing a bus device with existing generators.

[0112] Disclosed embodiments of the generator provide active cancellation of leakage current caused by unintended capacitive coupling between non-isolated and patient-isolated circuits of the generator. In addition to reducing patient risk, the reduction of leakage current may also lessen electromagnetic emissions.

[0113] These and other benefits of embodiments of the present invention will be apparent from the description to follow.

[0114] It will be appreciated that the terms “proximal” and “distal” are used herein with reference to a clinician gripping a handpiece. Thus, an end effector is distal with respect to the more proximal handpiece. It will be further appreciated that, for convenience and clarity, spatial terms such as “top” and “bottom” may also be used herein with respect to the clinician gripping the handpiece. However, surgical devices are used in many orientations and positions, and these terms are not intended to be limiting and absolute.

[0115] FIG. 1 illustrates one embodiment of a surgical system 100 comprising a generator 102 configurable for use with surgical devices. According to various embodiments, the generator 102 may be configurable for use with surgical devices of different types, including, for example, the ultrasonic surgical device 104 and electrosurgical or RF surgical device 106. Although in the embodiment of FIG. 1 the generator 102 is shown separate from the surgical devices 104, 106, in certain embodiments the generator 102 may be

formed integrally with either of the surgical devices 104, 106 to form a unitary surgical system.

[0116] FIG. 2 illustrates one embodiment of an example ultrasonic device 104 that may be used for transection and/or sealing. The device 104 may comprise a hand piece 116 which may, in turn, comprise an ultrasonic transducer 114. The transducer 114 may be in electrical communication with the generator 102, for example, via a cable 112 (e.g., a multi-conductor cable). The transducer 114 may comprise piezoceramic elements, or other elements or components suitable for converting the electrical energy of a drive signal into mechanical vibrations. When activated by the generator 102, the ultrasonic transducer 114 may cause longitudinal vibration. The vibration may be transmitted through an instrument portion 124 of the device 104 (e.g., via a waveguide embedded in an outer sheath) to an end effector 126 of the instrument portion 124.

[0117] FIG. 3 illustrates one embodiment of the end effector 126 of the example ultrasonic device 104. The end effector 126 may comprise a blade 151 that may be coupled to the ultrasonic transducer 114 via the wave guide (not shown). When driven by the transducer 114, the blade 151 may vibrate and, when brought into contact with tissue, may cut and/or coagulate the tissue, as described herein. According to various embodiments, and as illustrated in FIG. 3, the end effector 126 may also comprise a clamp arm 155 that may be configured for cooperative action with the blade 151 of the end effector 126. With the blade 151, the clamp arm 155 may comprise a set of jaws 140. The clamp arm 155 may be pivotally connected at a distal end of a shaft 153 of the instrument portion 124. The clamp arm 155 may include a clamp arm tissue pad 163, which may be formed from TEFLON® or other suitable low-friction material. The pad 163 may be mounted for cooperation with the blade 151, with pivotal movement of the clamp arm 155 positioning the clamp pad 163 in substantially parallel relationship to, and in contact with, the blade 151. By this construction, a tissue bite to be clamped may be grasped between the tissue pad 163 and the blade 151. The tissue pad 163 may be provided with a sawtooth-like configuration including a plurality of axially spaced, proximally extending gripping teeth 161 to enhance the gripping of tissue in cooperation with the blade 151. The clamp arm 155 may transition from the open position shown in FIG. 3 to a closed position (with the clamp arm 155 in contact with or proximity to the blade 151) in any suitable manner. For example, the hand piece 116 may comprise a jaw closure trigger 138. When actuated by a clinician, the jaw closure trigger 138 may pivot the clamp arm 155 in any suitable manner.

[0118] The generator 102 may be activated to provide the drive signal to the transducer 114 in any suitable manner. For example, the generator 102 may comprise a foot switch 120 coupled to the generator 102 via a footswitch cable 122 (FIG. 8). A clinician may activate the transducer 114, and thereby the transducer 114 and blade 151, by depressing the foot switch 120. In addition, or instead of the foot switch 120 some embodiments of the device 104 may utilize one or more switches positioned on the hand piece 116 that, when activated, may cause the generator 102 to activate the transducer 114. In one embodiment, for example, the one or more switches may comprise a pair of toggle buttons 136a, 136b, for example, to determine an operating mode of the device 104. When the toggle button 136a is depressed, for example, the ultrasonic generator 102 may provide a maxi-

imum drive signal to the transducer 114, causing it to produce maximum ultrasonic energy output. Depressing toggle button 136b may cause the ultrasonic generator 102 to provide a user-selectable drive signal to the transducer 114, causing it to produce less than the maximum ultrasonic energy output. The device 104 additionally or alternatively may comprise a second switch to, for example, indicate a position of a jaw closure trigger 138 for operating jaws 140 of the end effector 126. Also, in some embodiments, the ultrasonic generator 102 may be activated based on the position of the jaw closure trigger 138, (e.g., as the clinician depresses the jaw closure trigger 138 to close the jaws 140, ultrasonic energy may be applied.

[0119] Additionally or alternatively, the one or more switches may comprise a toggle button 136c that, when depressed, causes the generator 102 to provide a pulsed output. The pulses may be provided at any suitable frequency and grouping, for example. In certain embodiments, the power level of the pulses may be the power levels associated with toggle buttons 136a,b (maximum, less than maximum), for example.

[0120] It will be appreciated that a device 104 may comprise any combination of the toggle buttons 136a,b,c. For example, the device 104 could be configured to have only two toggle buttons: a toggle button 136a for producing maximum ultrasonic energy output and a toggle button 136c for producing a pulsed output at either the maximum or less than maximum power level per. In this way, the drive signal output configuration of the generator 102 could be 5 continuous signals and 5 or 4 or 3 or 2 or 1 pulsed signals. In certain embodiments, the specific drive signal configuration may be controlled based upon, for example, EEPROM settings in the generator 102 and/or user power level selection(s).

[0121] In certain embodiments, a two-position switch may be provided as an alternative to a toggle button 136c. For example, a device 104 may include a toggle button 136a for producing a continuous output at a maximum power level and a two-position toggle button 136b. In a first detented position, toggle button 136b may produce a continuous output at a less than maximum power level, and in a second detented position the toggle button 136b may produce a pulsed output (e.g., at either a maximum or less than maximum power level, depending upon the EEPROM settings).

[0122] In some embodiments, the end effector 126 may also comprise a pair of electrodes 159, 157. The electrodes 159, 157 may be in communication with the generator 102, for example, via the cable 112. The electrodes 159, 157 may be used, for example, to measure an impedance of a tissue bite present between the clamp arm 155 and the blade 151. The generator 102 may provide a signal (e.g., a non-therapeutic signal) to the electrodes 159, 157. The impedance of the tissue bite may be found, for example, by monitoring the current, voltage, etc. of the signal.

[0123] FIG. 4 illustrates one embodiment of an example electrosurgical device 106 that may also be used for transection and sealing. According to various embodiments, the transection and sealing device 106 may comprise a hand piece assembly 130, a shaft 165 and an end effector 132. The shaft 165 may be rigid (e.g., for laparoscopic and/or open surgical application) or flexible, as shown, (e.g., for endoscopic application). In various embodiments, the shaft 165 may comprise one or more articulation points. The end

effector 132 may comprise jaws 144 having a first jaw member 167 and a second jaw member 169. The first jaw member 167 and second jaw member 169 may be connected to a clevis 171, which, in turn, may be coupled to the shaft 165. A translating member 173 may extend within the shaft 165 from the end effector 132 to the hand piece 130. At the hand piece 130, the shaft 165 may be directly or indirectly coupled to a jaw closure trigger 142 (FIG. 4).

[0124] The jaw members 167, 169 of the end effector 132 may comprise respective electrodes 177, 179. The electrodes 177, 179 may be connected to the generator 102 via electrical leads 187a, 187b (FIG. 5) extending from the end effector 132 through the shaft 165 and hand piece 130 and ultimately to the generator 102 (e.g., by a multiconductor cable 128). The generator 102 may provide a drive signal to the electrodes 177, 179 to bring about a therapeutic effect to tissue present within the jaw members 167, 169. The electrodes 177, 179 may comprise an active electrode and a return electrode, wherein the active electrode and the return electrode can be positioned against, or adjacent to, the tissue to be treated such that current can flow from the active electrode to the return electrode through the tissue. As illustrated in FIG. 4, the end effector 132 is shown with the jaw members 167, 169 in an open position. A reciprocating blade 175 is illustrated between the jaw members 167, 169.

[0125] FIGS. 5, 6 and 7 illustrate one embodiment of the end effector 132 shown in FIG. 4. To close the jaws 144 of the end effector 132, a clinician may cause the jaw closure trigger 142 to pivot along arrow 183 from a first position to a second position. This may cause the jaws 144 to open and close according to any suitable method. For example, motion of the jaw closure trigger 142 may, in turn, cause the translating member 173 to translate within a bore 185 of the shaft 165. A distal portion of the translating member 173 may be coupled to a reciprocating member 197 such that distal and proximal motion of the translating member 173 causes corresponding distal and proximal motion of the reciprocating member. The reciprocating member 197 may have shoulder portions 191a, 191b, while the jaw members 167, 169 may have corresponding cam surfaces 189a, 189b. As the reciprocating member 197 is translated distally from the position shown in FIG. 6 to the position shown in FIG. 7, the shoulder portions 191a, 191b may contact the cam surfaces 189a, 189b, causing the jaw members 167, 169 to transition to the closed position. Also, in various embodiments, the blade 175 may be positioned at a distal end of the reciprocating member 197. As the reciprocating member extends to the fully distal position shown in FIG. 7, the blade 175 may be pushed through any tissue present between the jaw members 167, 169, in the process, severing it.

[0126] In use, a clinician may place the end effector 132 and close the jaws 144 around a tissue bite to be acted upon, for example, by pivoting the jaw closure trigger 142 along arrow 183 as described. Once the tissue bite is secure between the jaws 144, the clinician may initiate the provision of RF or other electro-surgical energy by the generator 102 and through the electrodes 177, 179. The provision of RF energy may be accomplished in any suitable way. For example, the clinician may activate the foot switch 120 (FIG. 8) of the generator 102 to initiate the provision of RF energy. Also, for example, the hand piece 130 may comprise one or more switches 181 that may be actuated by the clinician to cause the generator 102 to begin providing RF energy. Additionally, in some embodiments, RF energy may

be provided based on the position of the jaw closure trigger **142**. For example, when the trigger **142** is fully depressed (indicating that the jaws **144** are closed), RF energy may be provided. Also, according to various embodiments, the blade **175** may be advanced during closure of the jaws **144** or may be separately advanced by the clinician after closure of the jaws **144** (e.g., after a RF energy has been applied to the tissue).

[0127] FIG. **8** is a diagram of the surgical system **100** of FIG. **1**. In various embodiments, the generator **102** may comprise several separate functional elements, such as modules and/or blocks. Different functional elements or modules may be configured for driving the different kinds of surgical devices **104**, **106**. For example an ultrasonic generator module **108** may drive an ultrasonic device, such as the ultrasonic device **104**. An electrosurgery/RF generator module **110** may drive the electrosurgical device **106**. For example, the respective modules **108**, **110** may generate respective drive signals for driving the surgical devices **104**, **106**. In various embodiments, the ultrasonic generator module **108** and/or the electrosurgery/RF generator module **110** each may be formed integrally with the generator **102**. Alternatively, one or more of the modules **108**, **110** may be provided as a separate circuit module electrically coupled to the generator **102**. (The modules **108** and **110** are shown in phantom to illustrate this option.) Also, in some embodiments, the electrosurgery/RF generator module **110** may be formed integrally with the ultrasonic generator module **108**, or vice versa.

[0128] In accordance with the described embodiments, the ultrasonic generator module **108** may produce a drive signal or signals of particular voltages, currents, and frequencies, e.g. 55,500 cycles per second (Hz). The drive signal or signals may be provided to the ultrasonic device **104**, and specifically to the transducer **114**, which may operate, for example, as described above. In one embodiment, the generator **102** may be configured to produce a drive signal of a particular voltage, current, and/or frequency output signal that can be stepped with high resolution, accuracy, and repeatability.

[0129] In accordance with the described embodiments, the electrosurgery/RF generator module **110** may generate a drive signal or signals with output power sufficient to perform bipolar electrosurgery using radio frequency (RF) energy. In bipolar electrosurgery applications. The drive signal may be provided, for example, to the electrodes **177**, **179** of the electrosurgical device **106**, for example, as described above. Accordingly, the generator **102** may be configured for therapeutic purposes by applying electrical energy to the tissue sufficient for treating the tissue (e.g., coagulation, cauterization, tissue welding, etc.).

[0130] The generator **102** may comprise an input device **145** (FIG. **1**) located, for example, on a front panel of the generator **102** console. The input device **145** may comprise any suitable device that generates signals suitable for programming the operation of the generator **102**. In operation, the user can program or otherwise control operation of the generator **102** using the input device **145**. The input device **145** may comprise any suitable device that generates signals that can be used by the generator (e.g., by one or more processors contained in the generator) to control the operation of the generator **102** (e.g., operation of the ultrasonic generator module **108** and/or electrosurgery/RF generator module **110**). In various embodiments, the input device **145**

includes one or more of buttons, switches, thumbwheels, keyboard, keypad, touch screen monitor, pointing device, remote connection to a general purpose or dedicated computer. In other embodiments, the input device **145** may comprise a suitable user interface, such as one or more user interface screens displayed on a touch screen monitor, for example. Accordingly, by way of the input device **145**, the user can set or program various operating parameters of the generator, such as, for example, current (I), voltage (V), frequency (f), and/or period (T) of a drive signal or signals generated by the ultrasonic generator module **108** and/or electrosurgery/RF generator module **110**.

[0131] The generator **102** may also comprise an output device **146** (FIG. **1**) located, for example, on a front panel of the generator **102** console. The output device **146** includes one or more devices for providing a sensory feedback to a user. Such devices may comprise, for example, visual feedback devices (e.g., an LCD display screen, LED indicators), audio feedback devices (e.g., a speaker, a buzzer) or tactile feedback devices (e.g., haptic actuators).

[0132] Although certain modules and/or blocks of the generator **102** may be described by way of example, it can be appreciated that a greater or lesser number of modules and/or blocks may be used and still fall within the scope of the embodiments. Further, although various embodiments may be described in terms of modules and/or blocks to facilitate description, such modules and/or blocks may be implemented by one or more hardware components, e.g., processors, Digital Signal Processors (DSPs), Programmable Logic Devices (PLDs), Application Specific Integrated Circuits (ASICs), circuits, registers and/or software components, e.g., programs, subroutines, logic and/or combinations of hardware and software components.

[0133] In one embodiment, the ultrasonic generator drive module **108** and electrosurgery/RF drive module **110** may comprise one or more embedded applications implemented as firmware, software, hardware, or any combination thereof. The modules **108**, **110** may comprise various executable modules such as software, programs, data, drivers, application program interfaces (APIs), and so forth. The firmware may be stored in nonvolatile memory (NVM), such as in bit-masked read-only memory (ROM) or flash memory. In various implementations, storing the firmware in ROM may preserve flash memory. The NVM may comprise other types of memory including, for example, programmable ROM (PROM), erasable programmable ROM (EPROM), electrically erasable programmable ROM (EEPROM), or battery backed random-access memory (RAM) such as dynamic RAM (DRAM), Double-Data-Rate DRAM (DDRAM), and/or synchronous DRAM (SDRAM).

[0134] In one embodiment, the modules **108**, **110** comprise a hardware component implemented as a processor for executing program instructions for monitoring various measurable characteristics of the devices **104**, **106** and generating a corresponding output drive signal or signals for operating the devices **104**, **106**. In embodiments in which the generator **102** is used in conjunction with the device **104**, the drive signal may drive the ultrasonic transducer **114** in cutting and/or coagulation operating modes. Electrical characteristics of the device **104** and/or tissue may be measured and used to control operational aspects of the generator **102** and/or provided as feedback to the user. In embodiments in which the generator **102** is used in conjunction with the device **106**, the drive signal may supply electrical energy



(e.g., RF energy) to the end effector **132** in cutting, coagulation and/or desiccation modes. Electrical characteristics of the device **106** and/or tissue may be measured and used to control operational aspects of the generator **102** and/or provided as feedback to the user. In various embodiments, as previously discussed, the hardware components may be implemented as DSP, PLD, ASIC, circuits, and/or registers. In one embodiment, the processor may be configured to store and execute computer software program instructions to generate the step function output signals for driving various components of the devices **104**, **106**, such as the ultrasonic transducer **114** and the end effectors **126**, **132**.

**[0135]** FIG. 9 illustrates an equivalent circuit **150** of an ultrasonic transducer, such as the ultrasonic transducer **114**, according to one embodiment. The circuit **150** comprises a first “motional” branch having a serially connected inductance  $L_s$ , resistance  $R_s$  and capacitance  $C_s$  that define the electromechanical properties of the resonator, and a second capacitive branch having a static capacitance  $C_0$ . Drive current  $I_g$  may be received from a generator at a drive voltage  $V_g$ , with motional current  $I_m$  flowing through the first branch and current  $I_g - I_m$  flowing through the capacitive branch. Control of the electromechanical properties of the ultrasonic transducer may be achieved by suitably controlling  $I_g$  and  $V_g$ . As explained above, known generator architectures may include a tuning inductor  $L_t$  (shown in phantom in FIG. 9) for tuning out in a parallel resonance circuit the static capacitance  $C_0$  at a resonant frequency so that substantially all of generator’s current output  $I_g$  flows through the motional branch. In this way, control of the motional branch current  $I_m$  is achieved by controlling the generator current output  $I_g$ . The tuning inductor  $L_t$  is specific to the static capacitance  $C_0$  of an ultrasonic transducer, however, and a different ultrasonic transducer having a different static capacitance requires a different tuning inductor  $L_t$ . Moreover, because the tuning inductor  $L_t$  is matched to the nominal value of the static capacitance  $C_0$  at a single resonant frequency, accurate control of the motional branch current  $I_m$  is assured only at that frequency, and as frequency shifts down with transducer temperature, accurate control of the motional branch current is compromised.

**[0136]** Various embodiments of the generator **102** may not rely on a tuning inductor  $L_t$  to monitor the motional branch current  $I_m$ . Instead, the generator **102** may use the measured value of the static capacitance  $C_0$  in between applications of power for a specific ultrasonic surgical device **104** (along with drive signal voltage and current feedback data) to determine values of the motional branch current  $I_m$  on a dynamic and ongoing basis (e.g., in real-time). Such embodiments of the generator **102** are therefore able to provide virtual tuning to simulate a system that is tuned or resonant with any value of static capacitance  $C_0$  at any frequency, and not just at a single resonant frequency dictated by a nominal value of the static capacitance  $C_0$ .

**[0137]** FIG. 10 is a simplified block diagram of one embodiment of the generator **102** for providing inductorless tuning as described above, among other benefits. FIGS. 11A-11C illustrate an architecture of the generator **102** of FIG. 10 according to one embodiment. With reference to FIG. 10, the generator **102** may comprise a patient isolated stage **152** in communication with a non-isolated stage **154** via a power transformer **156**. A secondary winding **158** of the power transformer **156** is contained in the isolated stage **152** and may comprise a tapped configuration (e.g., a

center-tapped or non-center tapped configuration) to define drive signal outputs **160a**, **160b**, **160c** for outputting drive signals to different surgical devices, such as, for example, an ultrasonic surgical device **104** and an electrosurgical device **106**. In particular, drive signal outputs **160a**, **160c** may output a drive signal (e.g., a 420V RMS drive signal) to an ultrasonic surgical device **104**, and drive signal outputs **160b**, **160c** may output a drive signal (e.g., a 100V RMS drive signal) to an electrosurgical device **106**, with output **160b** corresponding to the center tap of the power transformer **156**. The non-isolated stage **154** may comprise a power amplifier **162** having an output connected to a primary winding **164** of the power transformer **156**. In certain embodiments the power amplifier **162** may comprise a push-pull amplifier, for example. The non-isolated stage **154** may further comprise a programmable logic device **166** for supplying a digital output to a digital-to-analog converter (DAC) **168**, which in turn supplies a corresponding analog signal to an input of the power amplifier **162**. In certain embodiments the programmable logic device **166** may comprise a field-programmable gate array (FPGA), for example. The programmable logic device **166**, by virtue of controlling the power amplifier’s **162** input via the DAC **168**, may therefore control any of a number of parameters (e.g., frequency, waveform shape, waveform amplitude) of drive signals appearing at the drive signal outputs **160a**, **160b**, **160c**. In certain embodiments and as discussed below, the programmable logic device **166**, in conjunction with a processor (e.g., processor **174** discussed below), may implement a number of digital signal processing (DSP)-based and/or other control algorithms to control parameters of the drive signals output by the generator **102**.

**[0138]** Power may be supplied to a power rail of the power amplifier **162** by a switch-mode regulator **170**. In certain embodiments the switch-mode regulator **170** may comprise an adjustable buck regulator, for example. The non-isolated stage **154** may further comprise a processor **174**, which in one embodiment may comprise a DSP processor such as an Analog Devices ADSP-21469 SHARC DSP, available from Analog Devices, Norwood, Mass., for example. In certain embodiments the processor **174** may control operation of the switch-mode power converter **170** responsive to voltage feedback data received from the power amplifier **162** by the processor **174** via an analog-to-digital converter (ADC) **176**. In one embodiment, for example, the processor **174** may receive as input, via the ADC **176**, the waveform envelope of a signal (e.g., an RF signal) being amplified by the power amplifier **162**. The processor **174** may then control the switch-mode regulator **170** (e.g., via a pulse-width modulated (PWM) output) such that the rail voltage supplied to the power amplifier **162** tracks the waveform envelope of the amplified signal. By dynamically modulating the rail voltage of the power amplifier **162** based on the waveform envelope, the efficiency of the power amplifier **162** may be significantly improved relative to a fixed rail voltage amplifier schemes.

**[0139]** In certain embodiments and as discussed in further detail in connection with FIGS. 13A and 13B, the programmable logic device **166**, in conjunction with the processor **174**, may implement a direct digital synthesizer (DDS) control scheme to control the waveform shape, frequency and/or amplitude of drive signals output by the generator **102**. In one embodiment, for example, the programmable logic device **166** may implement a DDS control algorithm

268 by recalling waveform samples stored in a dynamically-updated look-up table (LUT), such as a RAM LUT which may be embedded in an FPGA. This control algorithm is particularly useful for ultrasonic applications in which an ultrasonic transducer, such as the ultrasonic transducer 114, may be driven by a clean sinusoidal current at its resonant frequency. Because other frequencies may excite parasitic resonances, minimizing or reducing the total distortion of the motional branch current may correspondingly minimize or reduce undesirable resonance effects. Because the waveform shape of a drive signal output by the generator 102 is impacted by various sources of distortion present in the output drive circuit (e.g., the power transformer 156, the power amplifier 162), voltage and current feedback data based on the drive signal may be input into an algorithm, such as an error control algorithm implemented by the processor 174, which compensates for distortion by suitably pre-distorting or modifying the waveform samples stored in the LUT on a dynamic, ongoing basis (e.g., in real-time). In one embodiment, the amount or degree of pre-distortion applied to the LUT samples may be based on the error between a computed motional branch current and a desired current waveform shape, with the error being determined on a sample-by-sample basis. In this way, the pre-distorted LUT samples, when processed through the drive circuit, may result in a motional branch drive signal having the desired waveform shape (e.g., sinusoidal) for optimally driving the ultrasonic transducer. In such embodiments, the LUT waveform samples will therefore not represent the desired waveform shape of the drive signal, but rather the waveform shape that is required to ultimately produce the desired waveform shape of the motional branch drive signal when distortion effects are taken into account.

[0140] The non-isolated stage 154 may further comprise an ADC 178 and an ADC 180 coupled to the output of the power transformer 156 via respective isolation transformers 182, 184 for respectively sampling the voltage and current of drive signals output by the generator 102. In certain embodiments, the ADCs 178, 180 may be configured to sample at high speeds (e.g., 80 Msps) to enable oversampling of the drive signals. In one embodiment, for example, the sampling speed of the ADCs 178, 180 may enable approximately 200× (depending on drive frequency) oversampling of the drive signals. In certain embodiments, the sampling operations of the ADCs 178, 180 may be performed by a single ADC receiving input voltage and current signals via a two-way multiplexer. The use of high-speed sampling in embodiments of the generator 102 may enable, among other things, calculation of the complex current flowing through the motional branch (which may be used in certain embodiments to implement DDS-based waveform shape control described above), accurate digital filtering of the sampled signals, and calculation of real power consumption with a high degree of precision. Voltage and current feedback data output by the ADCs 178, 180 may be received and processed (e.g., FIFO buffering, multiplexing) by the programmable logic device 166 and stored in data memory for subsequent retrieval by, for example, the processor 174. As noted above, voltage and current feedback data may be used as input to an algorithm for pre-distorting or modifying LUT waveform samples on a dynamic and ongoing basis. In certain embodiments, this may require each stored voltage and current feedback data pair to be indexed based on, or otherwise associated with, a corresponding LUT sample that

was output by the programmable logic device 166 when the voltage and current feedback data pair was acquired. Synchronization of the LUT samples and the voltage and current feedback data in this manner contributes to the correct timing and stability of the pre-distortion algorithm.

[0141] In certain embodiments, the voltage and current feedback data may be used to control the frequency and/or amplitude (e.g., current amplitude) of the drive signals. In one embodiment, for example, voltage and current feedback data may be used to determine impedance phase. The frequency of the drive signal may then be controlled to minimize or reduce the difference between the determined impedance phase and an impedance phase setpoint (e.g., 0°), thereby minimizing or reducing the effects of harmonic distortion and correspondingly enhancing impedance phase measurement accuracy. The determination of phase impedance and a frequency control signal may be implemented in the processor 174, for example, with the frequency control signal being supplied as input to a DDS control algorithm implemented by the programmable logic device 166.

[0142] In another embodiment, for example, the current feedback data may be monitored in order to maintain the current amplitude of the drive signal at a current amplitude setpoint. The current amplitude setpoint may be specified directly or determined indirectly based on specified voltage amplitude and power setpoints. In certain embodiments, control of the current amplitude may be implemented by control algorithm, such as, for example, a proportional-integral-derivative (PID) control algorithm, in the processor 174. Variables controlled by the control algorithm to suitably control the current amplitude of the drive signal may include, for example, the scaling of the LUT waveform samples stored in the programmable logic device 166 and/or the full-scale output voltage of the DAC 168 (which supplies the input to the power amplifier 162) via a DAC 186.

[0143] The non-isolated stage 154 may further comprise a processor 190 for providing, among other things user interface (UI) functionality. In one embodiment, the processor 190 may comprise an Atmel AT91SAM9263 processor having an ARM 926EJ-S core, available from Atmel Corporation, San Jose, Calif., for example. Examples of UI functionality supported by the processor 190 may include audible and visual user feedback, communication with peripheral devices (e.g., via a Universal Serial Bus (USB) interface), communication with the footswitch 120, communication with an input device 145 (e.g., a touch screen display) and communication with an output device 146 (e.g., a speaker). The processor 190 may communicate with the processor 174 and the programmable logic device (e.g., via serial peripheral interface (SPI) buses). Although the processor 190 may primarily support UI functionality, it may also coordinate with the processor 174 to implement hazard mitigation in certain embodiments. For example, the processor 190 may be programmed to monitor various aspects of user input and/or other inputs (e.g., touch screen inputs, footswitch 120 inputs, temperature sensor inputs) and may disable the drive output of the generator 102 when an erroneous condition is detected.

[0144] In certain embodiments, both the processor 174 and the processor 190 may determine and monitor the operating state of the generator 102. For the processor 174, the operating state of the generator 102 may dictate, for example, which control and/or diagnostic processes are implemented by the processor 174. For the processor 190,

the operating state of the generator **102** may dictate, for example, which elements of a user interface (e.g., display screens, sounds) are presented to a user. The processors **174**, **190** may independently maintain the current operating state of the generator **102** and recognize and evaluate possible transitions out of the current operating state. The processor **174** may function as the master in this relationship and determine when transitions between operating states are to occur. The processor **190** may be aware of valid transitions between operating states and may confirm if a particular transition is appropriate. For example, when the processor **174** instructs the processor **190** to transition to a specific state, the processor **190** may verify that requested transition is valid. In the event that a requested transition between states is determined to be invalid by the processor **190**, the processor **190** may cause the generator **102** to enter a failure mode.

**[0145]** The non-isolated stage **154** may further comprise a controller **196** for monitoring input devices **145** (e.g., a capacitive touch sensor used for turning the generator **102** on and off, a capacitive touch screen). In certain embodiments, the controller **196** may comprise at least one processor and/or other controller device in communication with the processor **190**. In one embodiment, for example, the controller **196** may comprise a processor (e.g., a Mega168 8-bit controller available from Atmel) configured to monitor user input provided via one or more capacitive touch sensors. In one embodiment, the controller **196** may comprise a touch screen controller (e.g., a QT5480 touch screen controller available from Atmel) to control and manage the acquisition of touch data from a capacitive touch screen.

**[0146]** In certain embodiments, when the generator **102** is in a “power off” state, the controller **196** may continue to receive operating power (e.g., via a line from a power supply of the generator **102**, such as the power supply **211** discussed below). In this way, the controller **196** may continue to monitor an input device **145** (e.g., a capacitive touch sensor located on a front panel of the generator **102**) for turning the generator **102** on and off. When the generator **102** is in the power off state, the controller **196** may wake the power supply (e.g., enable operation of one or more DC/DC voltage converters **213** of the power supply **211**) if activation of the “on/off” input device **145** by a user is detected. The controller **196** may therefore initiate a sequence for transitioning the generator **102** to a “power on” state. Conversely, the controller **196** may initiate a sequence for transitioning the generator **102** to the power off state if activation of the “on/off” input device **145** is detected when the generator **102** is in the power on state. In certain embodiments, for example, the controller **196** may report activation of the “on/off” input device **145** to the processor **190**, which in turn implements the necessary process sequence for transitioning the generator **102** to the power off state. In such embodiments, the controller **196** may have no independent ability for causing the removal of power from the generator **102** after its power on state has been established.

**[0147]** In certain embodiments, the controller **196** may cause the generator **102** to provide audible or other sensory feedback for alerting the user that a power on or power off sequence has been initiated. Such an alert may be provided at the beginning of a power on or power off sequence and prior to the commencement of other processes associated with the sequence.

**[0148]** In certain embodiments, the isolated stage **152** may comprise an instrument interface circuit **198** to, for example, provide a communication interface between a control circuit of a surgical device (e.g., a control circuit comprising handpiece switches) and components of the non-isolated stage **154**, such as, for example, the programmable logic device **166**, the processor **174** and/or the processor **190**. The instrument interface circuit **198** may exchange information with components of the non-isolated stage **154** via a communication link that maintains a suitable degree of electrical isolation between the stages **152**, **154**, such as, for example, an infrared (IR)-based communication link. Power may be supplied to the instrument interface circuit **198** using, for example, a low-dropout voltage regulator powered by an isolation transformer driven from the non-isolated stage **154**.

**[0149]** In one embodiment, the instrument interface circuit **198** may comprise a programmable logic device **200** (e.g., an FPGA) in communication with a signal conditioning circuit **202**. The signal conditioning circuit **202** may be configured to receive a periodic signal from the programmable logic device **200** (e.g., a 2 kHz square wave) to generate a bipolar interrogation signal having an identical frequency. The interrogation signal may be generated, for example, using a bipolar current source fed by a differential amplifier. The interrogation signal may be communicated to a surgical device control circuit (e.g., by using a conductive pair in a cable that connects the generator **102** to the surgical device) and monitored to determine a state or configuration of the control circuit. As discussed below in connection with FIGS. **16-32**, for example, the control circuit may comprise a number of switches, resistors and/or diodes to modify one or more characteristics (e.g., amplitude, rectification) of the interrogation signal such that a state or configuration of the control circuit is uniquely discernable based on the one or more characteristics. In one embodiment, for example, the signal conditioning circuit **202** may comprise an ADC for generating samples of a voltage signal appearing across inputs of the control circuit resulting from passage of interrogation signal therethrough. The programmable logic device **200** (or a component of the non-isolated stage **154**) may then determine the state or configuration of the control circuit based on the ADC samples.

**[0150]** In one embodiment, the instrument interface circuit **198** may comprise a first data circuit interface **204** to enable information exchange between the programmable logic device **200** (or other element of the instrument interface circuit **198**) and a first data circuit disposed in or otherwise associated with a surgical device. In certain embodiments and with reference to FIGS. **33E-33G**, for example, a first data circuit **206** may be disposed in a cable integrally attached to a surgical device handpiece, or in an adaptor for interfacing a specific surgical device type or model with the generator **102**. In certain embodiments, the first data circuit may comprise a non-volatile storage device, such as an electrically erasable programmable read-only memory (EEPROM) device. In certain embodiments and referring again to FIG. **10**, the first data circuit interface **204** may be implemented separately from the programmable logic device **200** and comprise suitable circuitry (e.g., discrete logic devices, a processor) to enable communication between the programmable logic device **200** and the first data circuit. In other embodiments, the first data circuit interface **204** may be integral with the programmable logic device **200**.

[0151] In certain embodiments, the first data circuit 206 may store information pertaining to the particular surgical device with which it is associated. Such information may include, for example, a model number, a serial number, a number of operations in which the surgical device has been used, and/or any other type of information. This information may be read by the instrument interface circuit 198 (e.g., by the programmable logic device 200), transferred to a component of the non-isolated stage 154 (e.g., to programmable logic device 166, processor 174 and/or processor 190) for presentation to a user via an output device 146 and/or for controlling a function or operation of the generator 102. Additionally, any type of information may be communicated to first data circuit 206 for storage therein via the first data circuit interface 204 (e.g., using the programmable logic device 200). Such information may comprise, for example, an updated number of operations in which the surgical device has been used and/or dates and/or times of its usage.

[0152] As discussed previously, a surgical instrument may be detachable from a handpiece (e.g., instrument 124 may be detachable from handpiece 116) to promote instrument interchangeability and/or disposability. In such cases, known generators may be limited in their ability to recognize particular instrument configurations being used and to optimize control and diagnostic processes accordingly. The addition of readable data circuits to surgical device instruments to address this issue is problematic from a compatibility standpoint, however. For example, designing a surgical device to remain backwardly compatible with generators that lack the requisite data reading functionality may be impractical due to, for example, differing signal schemes, design complexity and cost. Embodiments of instruments discussed below in connection with FIGS. 16-32 address these concerns by using data circuits that may be implemented in existing surgical instruments economically and with minimal design changes to preserve compatibility of the surgical devices with current generator platforms.

[0153] Additionally, embodiments of the generator 102 may enable communication with instrument-based data circuits, such as those described below in connection with FIGS. 16-32 and FIGS. 33A-33C. For example, the generator 102 may be configured to communicate with a second data circuit (e.g., data circuit 284 of FIG. 16) contained in an instrument (e.g., instrument 124 or 134) of a surgical device. The instrument interface circuit 198 may comprise a second data circuit interface 210 to enable this communication. In one embodiment, the second data circuit interface 210 may comprise a tri-state digital interface, although other interfaces may also be used. In certain embodiments, the second data circuit may generally be any circuit for transmitting and/or receiving data. In one embodiment, for example, the second data circuit may store information pertaining to the particular surgical instrument with which it is associated. Such information may include, for example, a model number, a serial number, a number of operations in which the surgical instrument has been used, and/or any other type of information. Additionally or alternatively, any type of information may be communicated to second data circuit for storage therein via the second data circuit interface 210 (e.g., using the programmable logic device 200). Such information may comprise, for example, an updated number of operations in which the instrument has been used and/or dates and/or times of its usage. In certain embodiments, the

second data circuit may transmit data acquired by one or more sensors (e.g., an instrument-based temperature sensor). In certain embodiments, the second data circuit may receive data from the generator 102 and provide an indication to a user (e.g., an LED indication or other visible indication) based on the received data.

[0154] In certain embodiments, the second data circuit and the second data circuit interface 210 may be configured such that communication between the programmable logic device 200 and the second data circuit can be effected without the need to provide additional conductors for this purpose (e.g., dedicated conductors of a cable connecting a handpiece to the generator 102). In one embodiment, for example, information may be communicated to and from the second data circuit using a 1-wire bus communication scheme implemented on existing cabling, such as one of the conductors used transmit interrogation signals from the signal conditioning circuit 202 to a control circuit in a handpiece. In this way, design changes or modifications to the surgical device that might otherwise be necessary are minimized or reduced. Moreover, as discussed in further detail below in connection with FIGS. 16-32 and FIGS. 33A-33C, because different types of communications can be implemented over a common physical channel (either with or without frequency-band separation), the presence of a second data circuit may be “invisible” to generators that do not have the requisite data reading functionality, thus enabling backward compatibility of the surgical device instrument.

[0155] In certain embodiments, the isolated stage 152 may comprise at least one blocking capacitor 296-1 connected to the drive signal output 160b to prevent passage of DC current to a patient. A single blocking capacitor may be required to comply with medical regulations or standards, for example. While failure in single-capacitor designs is relatively uncommon, such failure may nonetheless have negative consequences. In one embodiment, a second blocking capacitor 296-2 may be provided in series with the blocking capacitor 296-1, with current leakage from a point between the blocking capacitors 296-1, 296-2 being monitored by, for example, an ADC 298 for sampling a voltage induced by leakage current. The samples may be received by the programmable logic device 200, for example. Based on changes in the leakage current (as indicated by the voltage samples in the embodiment of FIG. 10), the generator 102 may determine when at least one of the blocking capacitors 296-1, 296-2 has failed. Accordingly, the embodiment of FIG. 10 may provide a benefit over single-capacitor designs having a single point of failure.

[0156] In certain embodiments, the non-isolated stage 154 may comprise a power supply 211 for outputting DC power at a suitable voltage and current. The power supply may comprise, for example, a 400 W power supply for outputting a 48 VDC system voltage. The power supply 211 may further comprise one or more DC/DC voltage converters 213 for receiving the output of the power supply to generate DC outputs at the voltages and currents required by the various components of the generator 102. As discussed above in connection with the controller 196, one or more of the DC/DC voltage converters 213 may receive an input from the controller 196 when activation of the “on/off” input device 145 by a user is detected by the controller 196 to enable operation of, or wake, the DC/DC voltage converters 213.

[0157] FIGS. 13A and 13B illustrate certain functional and structural aspects of one embodiment of the generator 102. Feedback indicating current and voltage output from the secondary winding 158 of the power transformer 156 is received by the ADCs 178, 180, respectively. As shown, the ADCs 178, 180 may be implemented as a 2-channel ADC and may sample the feedback signals at a high speed (e.g., 80 Msps) to enable oversampling (e.g., approximately 200× oversampling) of the drive signals. The current and voltage feedback signals may be suitably conditioned in the analog domain (e.g., amplified, filtered) prior to processing by the ADCs 178, 180. Current and voltage feedback samples from the ADCs 178, 180 may be individually buffered and subsequently multiplexed or interleaved into a single data stream within block 212 of the programmable logic device 166. In the embodiment of FIGS. 13A and 13B, the programmable logic device 166 comprises an FPGA.

[0158] The multiplexed current and voltage feedback samples may be received by a parallel data acquisition port (PDAP) implemented within block 214 of the processor 174. The PDAP may comprise a packing unit for implementing any of a number of methodologies for correlating the multiplexed feedback samples with a memory address. In one embodiment, for example, feedback samples corresponding to a particular LUT sample output by the programmable logic device 166 may be stored at one or more memory addresses that are correlated or indexed with the LUT address of the LUT sample. In another embodiment, feedback samples corresponding to a particular LUT sample output by the programmable logic device 166 may be stored, along with the LUT address of the LUT sample, at a common memory location. In any event, the feedback samples may be stored such that the address of an LUT sample from which a particular set of feedback samples originated may be subsequently ascertained. As discussed above, synchronization of the LUT sample addresses and the feedback samples in this way contributes to the correct timing and stability of the pre-distortion algorithm. A direct memory access (DMA) controller implemented at block 216 of the processor 174 may store the feedback samples (and any LUT sample address data, where applicable) at a designated memory location 218 of the processor 174 (e.g., internal RAM).

[0159] Block 220 of the processor 174 may implement a pre-distortion algorithm for pre-distorting or modifying the LUT samples stored in the programmable logic device 166 on a dynamic, ongoing basis. As discussed above, pre-distortion of the LUT samples may compensate for various sources of distortion present in the output drive circuit of the generator 102. The pre-distorted LUT samples, when processed through the drive circuit, will therefore result in a drive signal having the desired waveform shape (e.g., sinusoidal) for optimally driving the ultrasonic transducer.

[0160] At block 222 of the pre-distortion algorithm, the current through the motional branch of the ultrasonic transducer is determined. The motional branch current may be determined using Kirchoff's Current Law based on, for example, the current and voltage feedback samples stored at memory location 218 (which, when suitably scaled, may be representative of  $I_g$  and  $V_g$  in the model of FIG. 9 discussed above), a value of the ultrasonic transducer static capacitance  $C_0$  (measured or known a priori) and a known value of the drive frequency. A motional branch current sample for

each set of stored current and voltage feedback samples associated with a LUT sample may be determined.

[0161] At block 224 of the pre-distortion algorithm, each motional branch current sample determined at block 222 is compared to a sample of a desired current waveform shape to determine a difference, or sample amplitude error, between the compared samples. For this determination, the sample of the desired current waveform shape may be supplied, for example, from a waveform shape LUT 226 containing amplitude samples for one cycle of a desired current waveform shape. The particular sample of the desired current waveform shape from the LUT 226 used for the comparison may be dictated by the LUT sample address associated with the motional branch current sample used in the comparison. Accordingly, the input of the motional branch current to block 224 may be synchronized with the input of its associated LUT sample address to block 224. The LUT samples stored in the programmable logic device 166 and the LUT samples stored in the waveform shape LUT 226 may therefore be equal in number. In certain embodiments, the desired current waveform shape represented by the LUT samples stored in the waveform shape LUT 226 may be a fundamental sine wave. Other waveform shapes may be desirable. For example, it is contemplated that a fundamental sine wave for driving main longitudinal motion of an ultrasonic transducer superimposed with one or more other drive signals at other frequencies, such as a third order harmonic for driving at least two mechanical resonances for beneficial vibrations of transverse or other modes, could be used.

[0162] Each value of the sample amplitude error determined at block 224 may be transmitted to the LUT of the programmable logic device 166 (shown at block 228 in FIG. 13A) along with an indication of its associated LUT address. Based on the value of the sample amplitude error and its associated address (and, optionally, values of sample amplitude error for the same LUT address previously received), the LUT 228 (or other control block of the programmable logic device 166) may pre-distort or modify the value of the LUT sample stored at the LUT address such that the sample amplitude error is reduced or minimized. It will be appreciated that such pre-distortion or modification of each LUT sample in an iterative manner across the entire range of LUT addresses will cause the waveform shape of the generator's output current to match or conform to the desired current waveform shape represented by the samples of the waveform shape LUT 226.

[0163] Current and voltage amplitude measurements, power measurements and impedance measurements may be determined at block 230 of the processor 174 based on the current and voltage feedback samples stored at memory location 218. Prior to the determination of these quantities, the feedback samples may be suitably scaled and, in certain embodiments, processed through a suitable filter 232 to remove noise resulting from, for example, the data acquisition process and induced harmonic components. The filtered voltage and current samples may therefore substantially represent the fundamental frequency of the generator's drive output signal. In certain embodiments, the filter 232 may be a finite impulse response (FIR) filter applied in the frequency domain. Such embodiments may use the fast Fourier transform (FFT) of the output drive signal current and voltage signals. In certain embodiments, the resulting frequency spectrum may be used to provide additional genera-

tor functionality. In one embodiment, for example, the ratio of the second and/or third order harmonic component relative to the fundamental frequency component may be used as a diagnostic indicator.

[0164] At block 234, a root mean square (RMS) calculation may be applied to a sample size of the current feedback samples representing an integral number of cycles of the drive signal to generate a measurement  $I_{rms}$  representing the drive signal output current.

[0165] At block 236, a root mean square (RMS) calculation may be applied to a sample size of the voltage feedback samples representing an integral number of cycles of the drive signal to determine a measurement  $V_{rms}$  representing the drive signal output voltage.

[0166] At block 238, the current and voltage feedback samples may be multiplied point by point, and a mean calculation is applied to samples representing an integral number of cycles of the drive signal to determine a measurement  $P_a$  of the generator's real output power.

[0167] At block 240, measurement  $P_a$  of the generator's apparent output power may be determined as the product  $V_{rms} \cdot I_{rms}$ .

[0168] At block 242, measurement  $Z_m$  of the load impedance magnitude may be determined as the quotient  $V_{rms}/I_{rms}$ .

[0169] In certain embodiments, the quantities  $I_{rms}$ ,  $V_{rms}$ ,  $P_r$ ,  $P_a$  and  $Z_m$  determined at blocks 234, 236, 238, 240 and 242 may be used by the generator 102 to implement any of number of control and/or diagnostic processes. In certain embodiments, any of these quantities may be communicated to a user via, for example, an output device 146 integral with the generator 102 or an output device 146 connected to the generator 102 through a suitable communication interface (e.g., a USB interface). Various diagnostic processes may include, without limitation, handpiece integrity, instrument integrity, instrument attachment integrity, instrument overload, approaching instrument overload, frequency lock failure, over-voltage, over-current, over-power, voltage sense failure, current sense failure, audio indication failure, visual indication failure, short circuit, power delivery failure, blocking capacitor failure, for example.

[0170] Block 244 of the processor 174 may implement a phase control algorithm for determining and controlling the impedance phase of an electrical load (e.g., the ultrasonic transducer) driven by the generator 102. As discussed above, by controlling the frequency of the drive signal to minimize or reduce the difference between the determined impedance phase and an impedance phase setpoint (e.g.,  $0^\circ$ ), the effects of harmonic distortion may be minimized or reduced, and the accuracy of the phase measurement increased.

[0171] The phase control algorithm receives as input the current and voltage feedback samples stored in the memory location 218. Prior to their use in the phase control algorithm, the feedback samples may be suitably scaled and, in certain embodiments, processed through a suitable filter 246 (which may be identical to filter 232) to remove noise resulting from the data acquisition process and induced harmonic components, for example. The filtered voltage and current samples may therefore substantially represent the fundamental frequency of the generator's drive output signal.

[0172] At block 248 of the phase control algorithm, the current through the motional branch of the ultrasonic transducer is determined. This determination may be identical to

that described above in connection with block 222 of the pre-distortion algorithm. The output of block 248 may thus be, for each set of stored current and voltage feedback samples associated with a LUT sample, a motional branch current sample.

[0173] At block 250 of the phase control algorithm, impedance phase is determined based on the synchronized input of motional branch current samples determined at block 248 and corresponding voltage feedback samples. In certain embodiments, the impedance phase is determined as the average of the impedance phase measured at the rising edge of the waveforms and the impedance phase measured at the falling edge of the waveforms.

[0174] At block 252 of the of the phase control algorithm, the value of the impedance phase determined at block 222 is compared to phase setpoint 254 to determine a difference, or phase error, between the compared values.

[0175] At block 256 of the phase control algorithm, based on a value of phase error determined at block 252 and the impedance magnitude determined at block 242, a frequency output for controlling the frequency of the drive signal is determined. The value of the frequency output may be continuously adjusted by the block 256 and transferred to a DDS control block 268 (discussed below) in order to maintain the impedance phase determined at block 250 at the phase setpoint (e.g., zero phase error). In certain embodiments, the impedance phase may be regulated to a  $0^\circ$  phase setpoint. In this way, any harmonic distortion will be centered about the crest of the voltage waveform, enhancing the accuracy of phase impedance determination.

[0176] Block 258 of the processor 174 may implement an algorithm for modulating the current amplitude of the drive signal in order to control the drive signal current, voltage and power in accordance with user specified setpoints, or in accordance with requirements specified by other processes or algorithms implemented by the generator 102. Control of these quantities may be realized, for example, by scaling the LUT samples in the LUT 228 and/or by adjusting the full-scale output voltage of the DAC 168 (which supplies the input to the power amplifier 162) via a DAC 186. Block 260 (which may be implemented as a PID controller in certain embodiments) may receive as input current feedback samples (which may be suitably scaled and filtered) from the memory location 218. The current feedback samples may be compared to a "current demand"  $I_d$  value dictated by the controlled variable (e.g., current, voltage or power) to determine if the drive signal is supplying the necessary current. In embodiments in which drive signal current is the control variable, the current demand  $I_d$  may be specified directly by a current setpoint 262A ( $I_{sp}$ ). For example, an RMS value of the current feedback data (determined as in block 234) may be compared to user-specified RMS current setpoint  $I_{sp}$  to determine the appropriate controller action. If, for example, the current feedback data indicates an RMS value less than the current setpoint  $I_{sp}$ , LUT scaling and/or the full-scale output voltage of the DAC 168 may be adjusted by the block 260 such that the drive signal current is increased. Conversely, block 260 may adjust LUT scaling and/or the full-scale output voltage of the DAC 168 to decrease the drive signal current when the current feedback data indicates an RMS value greater than the current setpoint  $I_{sp}$ .

[0177] In embodiments in which the drive signal voltage is the control variable, the current demand  $I_d$  may be specified indirectly, for example, based on the current

required maintain a desired voltage setpoint **262B** ( $V_{sp}$ ) given the load impedance magnitude  $Z_m$  measured at block **242** (e.g.  $I_d = V_{sp}/Z_m$ ). Similarly, in embodiments in which drive signal power is the control variable, the current demand  $I_d$  may be specified indirectly, for example, based on the current required to maintain a desired power setpoint **262C** ( $P_{sp}$ ) given the voltage  $V_{rms}$  measured at blocks **236** (e.g.  $I_d = P_{sp}/V_{rms}$ ).

**[0178]** Block **268** may implement a DDS control algorithm for controlling the drive signal by recalling LUT samples stored in the LUT **228**. In certain embodiments, the DDS control algorithm be a numerically-controlled oscillator (NCO) algorithm for generating samples of a waveform at a fixed clock rate using a point (memory location)-skipping technique. The NCO algorithm may implement a phase accumulator, or frequency-to-phase converter, that functions as an address pointer for recalling LUT samples from the LUT **228**. In one embodiment, the phase accumulator may be a D step size, modulo N phase accumulator, where D is a positive integer representing a frequency control value, and N is the number of LUT samples in the LUT **228**. A frequency control value of D=1, for example, may cause the phase accumulator to sequentially point to every address of the LUT **228**, resulting in a waveform output replicating the waveform stored in the LUT **228**. When D>1, the phase accumulator may skip addresses in the LUT **228**, resulting in a waveform output having a higher frequency. Accordingly, the frequency of the waveform generated by the DDS control algorithm may therefore be controlled by suitably varying the frequency control value. In certain embodiments, the frequency control value may be determined based on the output of the phase control algorithm implemented at block **244**. The output of block **268** may supply the input of (DAC) **168**, which in turn supplies a corresponding analog signal to an input of the power amplifier **162**.

**[0179]** Block **270** of the processor **174** may implement a switch-mode converter control algorithm for dynamically modulating the rail voltage of the power amplifier **162** based on the waveform envelope of the signal being amplified, thereby improving the efficiency of the power amplifier **162**. In certain embodiments, characteristics of the waveform envelope may be determined by monitoring one or more signals contained in the power amplifier **162**. In one embodiment, for example, characteristics of the waveform envelope may be determined by monitoring the minima of a drain voltage (e.g., a MOSFET drain voltage) that is modulated in accordance with the envelope of the amplified signal. A minima voltage signal may be generated, for example, by a voltage minima detector coupled to the drain voltage. The minima voltage signal may be sampled by ADC **176**, with the output minima voltage samples being received at block **272** of the switch-mode converter control algorithm. Based on the values of the minima voltage samples, block **274** may control a PWM signal output by a PWM generator **276**, which, in turn, controls the rail voltage supplied to the power amplifier **162** by the switch-mode regulator **170**. In certain embodiments, as long as the values of the minima voltage samples are less than a minima target **278** input into block **262**, the rail voltage may be modulated in accordance with the waveform envelope as characterized by the minima voltage samples. When the minima voltage samples indicate low envelope power levels, for example, block **274** may cause a low rail voltage to be supplied to the power amplifier

**162**, with the full rail voltage being supplied only when the minima voltage samples indicate maximum envelope power levels. When the minima voltage samples fall below the minima target **278**, block **274** may cause the rail voltage to be maintained at a minimum value suitable for ensuring proper operation of the power amplifier **162**.

**[0180]** FIGS. **33A-33C** illustrate control circuits of surgical devices according to various embodiments. As discussed above in connection with FIG. **10**, a control circuit may modify characteristics of an interrogation signal transmitted by the generator **102**. The characteristics of the interrogation signal, which may uniquely indicate a state or configuration of the control circuit, can be discerned by the generator **102** and used to control aspects of its operation. The control circuits may be contained in an ultrasonic surgical device (e.g., in handpiece **116** of ultrasonic surgical device **104**), or in an electrosurgical device (e.g., in handpiece **130** of electrosurgical device **106**).

**[0181]** Referring to the embodiment of FIG. **33A**, control circuit **300-1** may be connected to the generator **102** to receive an interrogation signal (e.g., a bipolar interrogation signal at 2 kHz) from the signal conditioning circuit **202** (e.g., from generator terminals HS and SR (FIG. **10**) via a conductive pair of cable **112** or cable **128**). The control circuit **300-1** may comprise a first branch that includes series-connected diodes D1 and D2 and a switch SW1 connected in parallel with D2. The control circuit **300-1** may also comprise a second branch that includes series-connected diodes D3, D4 and D5, a switch SW2 connected in parallel with D4, and a resistor R1 connected in parallel with D5. In certain embodiments and as shown, D5 may be a Zener diode. The control circuit **300-1** may additionally comprise a data storage element **302** that, together with one or more components of the second branch (e.g., D5, R1), define a data circuit **304**. In certain embodiments, the data storage element **302**, and possibly other components of the data circuit **304**, may be contained in the instrument (e.g., instrument **124**, instrument **134**) of the surgical device, with other components of the control circuit **300-1** (e.g., SW1, SW2, D1, D2, D3, D4) being contained in the handpiece (e.g., handpiece **116**, handpiece **130**). In certain embodiments, the data storage element **302** may be a single-wire bus device (e.g., a single-wire protocol EEPROM), or other single-wire protocol or local interconnect network (LIN) protocol device. In one embodiment, for example, the data storage element **302** may comprise a Maxim DS28EC20 1-Wire® EEPROM, available from Maxim Integrated Products, Inc., Sunnyvale, Calif. The data storage element **302** is one example of a circuit element that may be contained in the data circuit **304**. The data circuit **304** may additionally or alternatively comprise one or more other circuit elements or components capable of transmitting or receiving data. Such circuit elements or components may be configured to, for example, transmit data acquired by one or more sensors (e.g., an instrument-based temperature sensor) and/or receive data from the generator **102** and provide an indication to a user (e.g., an LED indication or other visible indication) based on the received data.

**[0182]** During operation, an interrogation signal (e.g., a bipolar interrogation signal at 2 kHz) from the signal conditioning circuit **202** may be applied across both branches of the control circuit **300-1**. In this way, the voltage appearing across the branches may be uniquely determined by the states of SW1 and SW2. For example, when SW1 is open,

the voltage drop across the control circuit 300-1 for negative values of the interrogation signal will be sum of the forward voltage drops across D1 and D2. When SW1 is closed, the voltage drop for negative values of the interrogation signal will be determined by the forward voltage drop of D1 only. Thus, for example, with a forward voltage drop of 0.7 volts for each of D1 and D2, open and closed states of SW1 may correspond to voltage drops of 1.4 volts and 0.7 volts, respectively. In the same way, the voltage drop across the control circuit 300-1 for positive values of the interrogation signal may be uniquely determined by the state of SW2. For example, when SW2 is open, the voltage drop across the control circuit 300-1 will be the sum of the forward voltage drops across D3 and D4 (e.g., 1.4 volts) and the breakdown voltage of D5 (e.g., 3.3 volts). When SW2 is closed, the voltage drop across the control circuit 300-1 will be the sum of the forward voltage drop across D3 and the breakdown voltage of D5. Accordingly, the state or configuration of SW1 and SW2 may be discerned by the generator 102 based on the interrogation signal voltage appearing across the inputs of the control circuit 300-1 (e.g., as measured by an ADC of the signal conditioning circuit 202).

[0183] In certain embodiments, the generator 102 may be configured to communicate with the data circuit 304, and, in particular, with the data storage element 302, via the second data circuit interface 210 (FIG. 10) and the conductive pair of cable 112 or cable 128. The frequency band of the communication protocol used to communicate with the data circuit 304 may be higher than the frequency band of the interrogation signal. In certain embodiments, for example, the frequency of the communication protocol for the data storage element 302 may be, for example, 200 kHz or a significantly higher frequency, whereas the frequency of the interrogation signal used to determine the different states of SW1 and SW2 may be, for example, 2 kHz. Diode D5 may limit the voltage supplied to the data storage element 302 to a suitable operating range (e.g., 3.3-5V).

[0184] As explained above in connection with FIG. 10, the data circuit 304, and, in particular, the data storage element 302, may store information pertaining to the particular surgical instrument with which it is associated. Such information may be retrieved by the generator 102 and include, for example, a model number, a serial number, a number of operations in which the surgical instrument has been used, and/or any other type of information. Additionally, any type of information may be communicated from the generator 102 to the data circuit 304 for storage in the data storage element 302. Such information may comprise, for example, an updated number of operations in which the instrument has been used and/or dates and/or times of its usage.

[0185] As noted above, the data circuit 304 may additionally or alternatively comprise components or elements other than the data storage element 302 for transmitting or receiving data. Such components or elements may be configured to, for example, transmit data acquired by one or more sensors (e.g., an instrument-based temperature sensor) and/or receive data from the generator 102 and provide an indication to a user (e.g., an LED indication or other visible indication) based on the received data.

[0186] Embodiments of the control circuit may comprise additional switches. With reference to the embodiment of FIG. 33B, for example, control circuit 300-2 may comprise a first branch having a first switch SW1 and a second switch SW2 (for a total of three switches), with each combination

of SW1 and SW2 states corresponding to a unique voltage drop across the control circuit 300-2 for negative values of the interrogation signal. For example, the open and closed states of SW1 add or remove, respectively, the forward voltage drops of D2 and D3, and the open and closed states of SW2 add or remove, respectively, the forward voltage drop of D4. In the embodiment of FIG. 33C, the first branch of control circuit 300-3 comprises three switches (for a total of four switches), with the breakdown voltage of Zener diode D2 being used to distinguish changes in the voltage drop resulting from the operation of SW1 from voltage changes resulting from the operation of SW2 and SW3.

[0187] FIGS. 14 and 15 illustrate control circuits of surgical devices according to various embodiments. As discussed above in connection with FIG. 10, a control circuit may modify characteristics of an interrogation signal transmitted by the generator 102. The characteristics of the interrogation signal, which may uniquely indicate the state or configuration of the control circuit, can be discerned by the generator 102 and used to control aspects of its operation. The control circuit 280 of FIG. 14 may be contained in an ultrasonic surgical device (e.g., in handpiece 116 of ultrasonic surgical device 104), and the control circuit 282 of FIG. 15 may be contained in an electrosurgical device (e.g., in handpiece 130 of electrosurgical device 106).

[0188] Referring to FIG. 14, control circuit 280 may be connected to the generator 102 to receive an interrogation signal (e.g., a bipolar interrogation signal at 2 kHz) from the signal conditioning circuit 202 (e.g., from generator terminals HS and SR (FIG. 10) via a conductive pair of cable 112). The control circuit 280 may comprise a first switch SW1 in series with a first diode D1 to define a first branch, and a second switch SW2 in series with a second diode D2 to define a second branch. The first and second branches may be connected in parallel such that the forward conduction direction of D2 is opposite that of D1. The interrogation signal may be applied across both branches. When both SW1 and SW2 are open, the control circuit 280 may define an open circuit. When SW1 is closed and SW2 is open, the interrogation signal may undergo half-wave rectification in a first direction (e.g., positive half of interrogation signal blocked). When SW1 is open and SW2 is closed, the interrogation signal may undergo half-wave rectification in a second direction (e.g., negative half of interrogation signal blocked). When both SW1 and SW2 are closed, no rectification may occur. Accordingly, based on the different characteristics of the interrogation signal corresponding to the different states of SW1 and SW2, the state or configuration of the control circuit 280 may be discerned by the generator 102 based on a voltage signal appearing across the inputs of the control circuit 280 (e.g., as measured by an ADC of the signal conditioning circuit 202).

[0189] In certain embodiments and as shown in FIG. 14, the cable 112 may comprise a data circuit 206. The data circuit 206 may comprise, for example, a non-volatile storage device, such as an EEPROM device. The generator 102 may exchange information with the data circuit 206 via the first data circuit interface 204 as discussed above in connection with FIG. 10. Such information may be specific to a surgical device integral with, or configured for use with, the cable 112 and may comprise, for example, a model number, a serial number, a number of operations in which the surgical device has been used, and/or any other type of information. Information may also be communicated from



the generator **102** to the data circuit **206** for storage therein, as discussed above in connection with FIG. **10**. In certain embodiments and with reference to FIGS. **33E-33G**, the data circuit **206** may be disposed in an adaptor for interfacing a specific surgical device type or model with the generator **102**.

[**0190**] Referring to FIG. **15**, control circuit **282** may be connected to the generator **102** to receive an interrogation signal (e.g., a bipolar interrogation signal at 2 kHz) from the signal conditioning circuit **202** (e.g., from generator terminals HS and SR (FIG. **10**) via a conductive pair of cable **128**). The control circuit **282** may comprise series-connected resistors R2, R3 and R4, with switches SW1 and SW2 connected across R2 and R4, respectively. The interrogation signal may be applied across at least one of the series-connected resistors to generate a voltage drop across the control circuit **282**. For example, when both SW1 and SW2 are open, the voltage drop may be determined by R2, R3 and R4. When SW1 is closed and SW2 is open, the voltage drop may be determined by R3 and R4. When SW1 is open and SW2 is closed, the voltage drop may be determined by R2 and R3. When both SW1 and SW2 are closed, the voltage drop may be determined by R3. Accordingly, based on the voltage drop across the control circuit **282** (e.g., as measured by an ADC of the signal conditioning circuit **202**), the state or configuration of the control circuit **282** may be discerned by the generator **102**.

[**0191**] FIG. **16** illustrates one embodiment of a control circuit **280-1** of an ultrasonic surgical device, such as the ultrasonic surgical device **104**. The control circuit **280-1**, in addition to comprising components of the control circuit **280** of FIG. **14**, may comprise a data circuit **284** having a data storage element **286**. In certain embodiments, the data storage element **286**, and possibly other components of the data circuit **284**, may be contained in the instrument (e.g., instrument **124**) of the ultrasonic surgical device, with other components of the control circuit **280-1** (e.g., SW1, SW2, D1, D2, D3, D4, C1) being contained in the handpiece (e.g., handpiece **116**). In certain embodiments, the data storage element **286** may be a single-wire bus device (e.g., a single-wire protocol EEPROM), or other single-wire protocol or local interconnect network (LIN) protocol device. In one embodiment, for example, the data storage element **286** may comprise a Maxim DS28EC20 1-Wire® EEPROM, available from Maxim Integrated Products, Inc., Sunnyvale, Calif.

[**0192**] In certain embodiments, the generator **102** may be configured to communicate with the data circuit **284**, and, in particular, with the data storage element **286**, via the second data circuit interface **210** (FIG. **10**) and the conductive pair of the cable **112**. In particular, the frequency band of the communication protocol used to communicate with the data circuit **284** may be higher than the frequency band of the interrogation signal. In certain embodiments, for example, the frequency of the communication protocol for the data storage element **286** may be, for example, 200 kHz or a significantly higher frequency, whereas the frequency of the interrogation signal used to determine the different states of SW1 and SW2 may be, for example, 2 kHz. Accordingly, the value of capacitor C1 of the data circuit **284** may be selected such that the data storage element **286** is “hidden” from the relatively low frequency of the interrogation signal while allowing the generator **102** to communicate with the data storage element **286** at the higher frequency of the commu-

nication protocol. A series diode D3 may protect the data storage element **286** from negative cycles of the interrogation signal, and a parallel Zener diode D4 may limit the voltage supplied to the data storage element **286** to a suitable operating range (e.g., 3.3-5V). When in the forward conduction mode, D4 may also clamp negative cycles of the interrogation signal to ground.

[**0193**] As explained above in connection with FIG. **10**, the data circuit **284**, and, in particular, the data storage element **286**, may store information pertaining to the particular surgical instrument with which it is associated. Such information may be retrieved by the generator **102** and include, for example, a model number, a serial number, a number of operations in which the surgical instrument has been used, and/or any other type of information. Additionally, any type of information may be communicated from the generator **102** to the data circuit **284** for storage in the data storage element **286**. Such information may comprise, for example, an updated number of operations in which the instrument has been used and/or dates and/or times of its usage. Moreover, because the different types of communications between the generator **102** and the surgical device may be frequency-band separated, the presence of the data storage element **286** may be “invisible” to generators that do not have the requisite data reading functionality, thus enabling backward compatibility of the surgical device.

[**0194**] In certain embodiments and as shown in FIG. **17**, the data circuit **284-1** may comprise an inductor L1 to provide isolation of the data storage element **286** from the states of SW1 and SW2. The addition of L1 may additionally enable use of the data circuit **284-1** in electrosurgical devices. FIG. **18**, for example, illustrates one embodiment of a control circuit **282-1** that combines the control circuit **282** of FIG. **15** with the data circuit **284-1** of FIG. **17**.

[**0195**] In certain embodiments, a data circuit may comprise one or more switches to modify one or more characteristics (e.g., amplitude, rectification) of an interrogation signal received by the data circuit such that a state or configuration of the one or more switches is uniquely discernable based on the one or more characteristics. FIG. **19**, for example, illustrates one embodiment of a control circuit **282-2** in which the data circuit **284-2** comprises a switch SW3 connected in parallel with D4. An interrogation signal may be communicated from the generator **102** (e.g., from the signal conditioning circuit **202** of FIG. **10**) at a frequency sufficient for the interrogation signal to be received by the data circuit **284-2** via C1 but blocked from other portions of the control circuit **282-2** by L1. In this way, one or more characteristics of a first interrogation signal (e.g., a bipolar interrogation signal at 25 kHz) may be used to discern the state of SW3, and one or more characteristics of a second interrogation signal at a lower frequency (e.g., a bipolar interrogation signal at 2 kHz) may be used to discern the states of SW1 and SW2. Although the addition of SW3 is illustrated in connection with the control circuit **282-2** in an electrosurgical device, it will be appreciated that SW3 may be added to a control circuit of an ultrasonic surgical device, such as, for example, the control circuit **280-2** of FIG. **17**.

[**0196**] Additionally, it will be appreciated that switches in addition to SW3 may be added to a data circuit. As shown in FIGS. **20** and **21**, for example, embodiments of the data circuit **284-3** and **284-4**, respectively, may comprise a second switch SW4. In FIG. **20**, voltage values of Zener diodes

D5 and D6 may be selected such that their voltage values sufficiently differ to allow reliable discrimination of the interrogation signal in the presence of noise. The sum of the voltages values of D5 and D6 may be equal to or less than the voltage value of D4. In certain embodiments, depending upon the voltages values of D5 and D6, it may be possible to eliminate D4 from the embodiment of the data circuit 284-3 illustrated in FIG. 20.

[0197] In certain cases, the switches (e.g., SW1-SW4) may impede the ability of the generator 102 to communicate with the data storage element 286. In one embodiment, this issue may be addressed by declaring an error if the states of the switches are such that they will interfere with communication between the generator 102 and the data storage element 286. In another embodiment, the generator 102 may only permit communication with the data storage element 286 when determined by the generator 102 that the states of the switches will not interfere with the communication. Because the states of the switches may be unpredictable to an extent, the generator 102 may make this determination on a recurring basis. The addition of L1 in certain embodiments may prevent interference caused by switches external to the data circuit (e.g., SW1 and SW2). For switches contained within the data circuit (e.g., SW3 and SW4), isolation of the switches by frequency band separation may be realized by the addition of a capacitor C2 having a capacitance value significantly smaller than C1 (e.g.,  $C2 \ll C1$ ). Embodiments of data circuits 284-5, 284-6, 284-7 comprising C2 are shown in FIGS. 22-24, respectively.

[0198] In any of the embodiments of FIGS. 16-24, depending on the frequency response characteristics of D4, it may be desirable or necessary to add a fast diode in parallel with D4 and pointing in the same direction.

[0199] FIG. 25 illustrates one embodiment of a control circuit 280-5 in which communication between the generator 102 and a data storage element is implemented using an amplitude-modulated communication protocol (e.g., amplitude-modulated 1-Wire® protocol, amplitude-modulated LIN protocol). Amplitude modulation of the communication protocol on a high-frequency carrier (e.g., 8 MHz or higher) substantially increases frequency band separation between low frequency interrogation signals (e.g., interrogation signals at 2 kHz) and the native “baseband” frequency of the communication protocol used in the embodiments of FIGS. 16-24. The control circuit 280-5 may be similar to the control circuit 280-1 of FIG. 16, with the data circuit 288 comprising an additional capacitor C3 and resistor R5, which, in conjunction with D3, demodulate the amplitude-modulated communication protocol for receipt by the data storage element 286. As in the embodiment of FIG. 16, D3 may protect the data storage element 286 from negative cycles of the interrogation signal, and D4 may limit the voltage supplied to the data storage element 286 to a suitable operating range (e.g., 3.3-5V) and clamp negative cycles of the interrogation signal to ground when in the forward conduction mode. The increased frequency separation may allow C1 to be somewhat small relative to the embodiments of FIGS. 16-24. Additionally, the higher frequency of the carrier signal may also improve noise immunity of communications with the data storage element because it is further removed from the frequency range of electrical noise that may be generated by other surgical devices used in the same operating room environment. In certain embodiments, the relatively high frequency of the carrier in combination with

the frequency response characteristics of D4 may make it desirable or necessary to add a fast diode in parallel with D4 and pointing in the same direction.

[0200] With the addition of an inductor L1 to prevent interference with data storage element 286 communications caused by switches external to the data circuit 288 (e.g., SW1 and SW2), the data circuit 288 may be used in control circuits of electrosurgical instruments, as shown in the embodiment of the data circuit 288-1 of FIG. 26.

[0201] With the exception of C2 and R3, and the more likely need for D7, the embodiments of FIGS. 25 and 26 are similar to the “baseband” embodiments of FIGS. 16-24. For example, the manner in which switches may be added to the data circuits of FIGS. 19-21 is directly applicable to the embodiments of FIGS. 25 and 26 (including the possibility of eliminating D4 from the modulated-carrier equivalent of the FIG. 20). Modulated-carrier equivalents of the data circuits embodied in FIGS. 22-24 may simply require the addition of an appropriately-sized inductor L2 in series with C2 in order to isolate the interrogation frequency for the additional switches (e.g., SW3, SW4) to an intermediate frequency band between the carrier frequency and the lower interrogation frequency for switches external to the data circuit. An embodiment of one such data circuit 282-7 is shown in FIG. 27.

[0202] In the embodiment of FIG. 27, any interference with the generator’s ability to communicate with the data storage element 286 caused by states of SW1 and SW2 may be addressed as described above in connection with the embodiments of FIGS. 19-24. For example, the generator 102 may declare an error if switch states will prevent communication, or the generator 102 may only permit communication when determined by the generator 102 that the switch states will not cause interference.

[0203] In certain embodiments, the data circuit may not comprise a data storage element 286 (e.g., an EEPROM device) to store information. FIGS. 28-32 illustrate embodiments of control circuits that utilize resistive and/or inductive elements to modify one or more characteristics of an interrogation signal (e.g., amplitude, phase) such that a state or configuration of the control circuit may be uniquely discerned based on the one or more characteristics.

[0204] In FIG. 28, for example, the data circuit 290 may comprise an identification resistor R1, with the value of C1 selected such that R1 is “hidden” from a first low frequency interrogation signal (e.g., an interrogation signal at 2 kHz) for determining the states of SW1 and SW2. By measuring the voltage and/or current (e.g., amplitude, phase) at the inputs of the control circuit 280-6 resulting from a second interrogation signal within a substantially higher frequency band, the generator 102 may measure the value of R1 through C1 in order to determine which of a plurality of identification resistors is contained in the instrument. Such information may be used by the generator 102 to identify the instrument, or a particular characteristic of the instrument, so that control and diagnostic processes may be optimized. Any interference with the generator’s ability to measure R1 caused by states of SW1 and SW2 may be addressed by declaring an error if switch states will prevent measurement, or by maintaining the voltage of the second higher-frequency interrogation signal below the turn-on voltages of D1 and D2. Such interference may also be addressed by adding an inductor in series with the switch circuitry (L1 in FIG. 29) to block the second higher-frequency interrogation

signal while passing the first, lower-frequency interrogation signal. The addition of an inductor in this manner may also enable the use of the data circuit 290 in control circuits of electrosurgical instruments, as shown in the embodiment of the data circuit 290-2 of FIG. 30.

[0205] In certain embodiments, multiple capacitors C1 for allowing interrogation at multiple frequencies could be used to differentiate between a larger number of distinct R1 values for a given signal-to-noise ratio, or for a given set of component tolerances. In one such embodiment, inductors may be placed in series with all but the lowest value of C1 to create specific pass bands for different interrogation frequencies, as shown in the embodiment of the data circuit 290-3 in FIG. 31.

[0206] In embodiments of control circuits based on the control circuit 280 of FIG. 14, identification resistors may be measured without the need for frequency band separation. FIG. 32 illustrates one such embodiment, with R1 selected to have a relatively high value.

[0207] FIGS. 33D-33I illustrate embodiments of multi-conductor cables and adaptors that may be used to establish electrical communication between the generator 102 and a handpiece of a surgical device. In particular, the cables may transmit the generator drive signal to surgical device and enable control-based communications between the generator 102 and a control circuit of the surgical device. In certain embodiments, the cables may be integrally formed with the surgical device or configured for removable engagement by a suitable connector of the surgical device. Cables 112-1, 112-2 and 112-3 (FIGS. 33E-33G, respectively) may be configured for use with an ultrasonic surgical device (e.g., ultrasonic surgical device 104), and cable 128-1 (FIG. 33D) may be configured for use with an electrosurgical device (e.g., electrosurgical device 106). One or more of the cables may be configured to connect directly with the generator 102, such as cable 112-1, for example. In such embodiments, the cable may comprise a data circuit (e.g., data circuit 206) for storing information pertaining to the particular surgical device with which it is associated (e.g., a model number, a serial number, a number of operations in which the surgical device has been used, and/or any other type of information). In certain embodiments, one or more of the cables may connect to the generator 102 via an adaptor. For example, cables 112-2 and 112-3 may connect to the generator 102 via a first adaptor 292 (FIG. 33I), and cable 128-1 may connect to the generator 102 via a second adaptor 294 (FIG. 33H). In such embodiments, a data circuit (e.g., data circuit 206) may be disposed in the cable (e.g., cables 112-2 and 112-3) or in the adaptor (e.g., second adaptor 294).

[0208] In various embodiments, the generator 102 may be electrically isolated from the surgical devices 104, 106 in order to prevent undesired and potentially harmful currents in the patient. For example, if the generator 102 and the surgical devices 104, 106 were not electrically isolated, voltage provided to the devices 104, 106 via the drive signal could potentially change the electrical potential of patient tissue being acted upon by the device or devices 104, 106 and, thereby, result in undesired currents in the patient. It will be appreciated that such concerns may be more acute when the using an ultrasonic surgical device 104 that is not intended to pass any current through tissue. Accordingly, the remainder of the description of active cancellation of leakage current is described in terms of a ultrasonic surgical

device 104. It will be appreciated, however, that the systems and methods described herein may be applicable to electrosurgical devices 106 as well.

[0209] According to various embodiments, an isolation transformer, such as the isolation transformer 156, may be used to provide electrical isolation between the generator 102 and the surgical device 104. For example, the transformer 156 may provide isolation between the non-isolated stage 154 and the isolated stage 152 described above. The isolated stage 154 may be in communication with the surgical device 104. The drive signal may be provided by the generator 102 (e.g., the generator module 108) to the primary winding 164 of the isolation transformer 156 and provided to the surgical device 104 from the secondary winding 158 of the isolation transformer. Considering the non-idealities of real transformers, however, this arrangement may not provide complete electrical isolation. For example, a real transformer may have stray capacitance between the primary and secondary windings. The stray capacitance may prevent complete electrical isolation and allow electrical potential present on the primary winding to affect the potential of the secondary winding. This may result in leakage currents within the patient.

[0210] Contemporary industry standards, such as the International Electrotechnical Commission (IEC) 60601-1 standard limit allowable patient leakage current to 10  $\mu$ A or less. Leakage current may be passively reduced by providing a leakage capacitor between the secondary winding of the isolation transformer and ground (e.g., earth ground). The leakage capacitor may operate to smooth changes in patient-side potential coupled from the non-isolated side via the stray capacitance of the isolation transformer and thereby reduce leakage current. As the voltage, current, power and/or frequency of the drive signal provided by the generator 102 increase, however, the leakage current may also increase. In various embodiments, induced leakage current may increase beyond the capability of a passive leakage capacitor to keep it below 10  $\mu$ A and/or other leakage current standards.

[0211] Accordingly, various embodiments are directed to systems and methods for actively cancelling leakage current. FIG. 34 illustrates one embodiment of a circuit 800 for active cancellation of leakage current. The circuit 800 may be implemented as a part of or in conjunction with the generator 102. The circuit may comprise an isolation transformer 802 having a primary winding 804 and a secondary winding 806. The drive signal 816 may be provided across the primary winding 804, generating an isolated drive signal across the secondary winding 806. In addition to the isolated drive signal, stray capacitance 808 of the isolation transformer 802 may couple some component of the potential of the drive signal relative to ground 818 to the secondary winding 806 on the patient side.

[0212] A leakage capacitor 810 and active cancellation circuit 812 may be provided, as shown, connected between the secondary winding 806 and ground 818. The active cancellation circuit 812 may generate an inverse drive signal 814 that may be about 180° out of phase with the drive signal 816. The active cancellation circuit 812 may be electrically coupled to the leakage capacitor 810 to drive the leakage capacitor to a potential that, relative to ground 818, is about 180° out of phase with the drive signal 816. Accordingly, electrical charge on the patient-side secondary winding 806 may reach ground 818 via the leakage capacitor

**810** instead of through the patient, reducing leakage current. According to various embodiments, the leakage capacitor **810** may be designed to meet adequate, industry, government and/or design standards for robustness. For example, the leakage capacitor **810** may be a Y-type capacitor complying with the IEC 60384-14 standard and/or may comprise multiple physical capacitors in series.

[0213] FIG. 35 illustrates one embodiment of a circuit **820** that may be implemented by the generator **102** to provide active cancellation of leakage current. The circuit **820** may comprise a generator circuit **824** and a patient-side circuit **822**. The generator circuit **824** may generate and/or modulate the drive signal, as described herein. For example, in some embodiments, the generator circuit **824** may operate similar to the non-isolated stage **154** described above. Also, for example, the patient-side circuit **822** may operate similar to the isolated stage **152** described above.

[0214] Electrical isolation between the generator circuit **824** and the patient-side circuit **822** may be provided by an isolation transformer **826**. The primary winding **828** of the isolation transformer **826** may be coupled to the generator circuit **824**. For example, the generator circuit **824** may generate the drive signal across the primary winding **828**. The drive signal may be generated across the primary winding **828** according to any suitable method. For example, according to various embodiments, the primary winding **828** may comprise a center tap **829** that may be held to a DC voltage (e.g., 48 volts). The generator circuit **824** may comprise output stages **825**, **827** that are, respectively, coupled to the other ends of the primary winding **828**. Output stages **825**, **827** may cause currents corresponding to the drive signal to flow in the primary winding **828**. For example, positive portions of the drive signal may be realized when the output stage **827** pulls its output voltage lower than the center tap voltage, causing the output stage **827** to sink current from across the primary winding **828**. A corresponding current may be induced in the secondary winding **830**. Likewise, negative portions of the drive signal may be implemented when the output stage **827** pulls its output voltage lower than the center tap voltage, causing the output stage **825** to sink an opposite current across the primary winding **828**. This may induce a corresponding, opposite current in the secondary winding **830**. The patient-side circuit **822** may perform various signal conditioning and/or other processing to the isolated drive signal, which may be provided to a device **104** via output lines **821**, **823**.

[0215] An active cancellation transformer **832** may have a primary winding **834** and a secondary winding **836**. The primary winding **834** may be electrically coupled to the primary winding **828** of the isolation transformer **826** such that the drive signal is provided across the winding **834**. For example, the primary winding **834** may comprise two windings **843**, **845**. A first end **835** of the first winding **845** and a first end **839** of the second winding **843** may be electrically coupled to the center tap **829** of the winding **828**. A second end **841** of the first winding **845** may be electrically coupled to the output stage **827**, while a second end **837** of the second winding **843** may be electrically coupled to the output stage **825**. The secondary winding **836** of the cancellation transformer **832** may be coupled to ground **818** and to a first electrode of a cancellation capacitor **840**. The other electrode of the cancellation capacitor **840** may be coupled to the

output line **823**. An optional load resistor **838** may also be electrically coupled in parallel across the secondary winding **836**.

[0216] According to various embodiments, the secondary winding **836** of the active cancellation transformer may be wound and/or wired to the other components **840**, **838**, **818**, such that its polarity is opposite the polarity of the primary winding **834**. For example, an inverse drive signal may be induced across the secondary winding **836**. Relative to ground **818**, the inverse drive signal may be 180° out of phase with the drive signal provided across the primary winding **834** of the active cancellation transform **832**. In conjunction with the load resistor **838**, the secondary winding **836** may provide the inverse drive signal at the cancellation capacitor **840**. Accordingly, charge causing leakage potential appearing at the patient-side circuit **822** due to the drive signal may be drawn to the cancellation capacitor **840**. In this way, the capacitor **840**, secondary winding **836** and load resistor **838** may sink potential leakage current to ground **818**, minimizing patient leakage current.

[0217] According to various embodiments, the parameters of the components **832**, **838**, **840** may be selected to maximize leakage current cancellation and, in various embodiments, to lessen electromagnetic emissions. For example, the active cancellation transformer **832** may be made from materials and according to a construction that allows it to match the frequency, temperature, humidity and other characteristics of the isolation transformer **826**. Other parameters of the active transformer **832** (e.g., number of turns, turn ratios, etc.) may be selected to achieve a balance between minimizing output-induced current, electromagnetic (EM) emissions and leakage current due to applied external voltage. For example, the circuit **820** may be configured to meet the IEC 60601 or other suitable industry or government standards. The value of the load resistor **838** may be similarly chosen. In addition, the parameters of the cancellation capacitor **840** (e.g., capacitance, etc.) may be selected to match, as well as possible, the characteristics of the stray capacitances responsible for the inducing leakage current.

[0218] FIG. 36 illustrates an alternate embodiment of a circuit **842** that may be implemented by the generator **102** to provide active cancellation of leakage current. The circuit **842** may be similar to the circuit **820**, however, the secondary winding **836** of the active cancellation transformation **832** may be electrically coupled to the output line **823**. The cancellation capacitor **823** may be connected in series between the secondary winding **836** and ground **818**. The circuit **842** may operate in a manner similar to that of the circuit **820**. According to various embodiments, (e.g., when the active cancellation transformer **832** is a step-up transformer), the total working voltage, for example, as defined in IEC 60601-1, may be minimized.

[0219] FIG. 37 illustrates an alternate embodiment of a circuit **844** that may be implemented by the generator **102** to provide active cancellation of leakage current. The circuit **844** may omit the active cancellation transformer **832** and replace it with a second secondary winding **846** of the isolation transformer **826**. The second secondary winding **846** may be connected to the output line **823**. The cancellation capacitor **840** may be connected in series between the second secondary winding **846** and ground. The second secondary winding may be wound and or wired with a polarity opposite that of the primary winding **828** and the secondary winding **830**. Accordingly, when the drive signal

is present across the primary winding **828**, the inverse drive signal, as described above, may be present across the secondary winding **846**. Accordingly, the circuit **844** may cancel leakage current in a manner similar to that described above with respect to the circuits **820** and **842**. Omitting the active cancellation transformer **832**, as shown in circuit **844**, may reduce part count, cost and complexity.

[0220] FIG. **38** illustrates yet another embodiment of a circuit **848** that may be implemented by the generator **102** to provide active cancellation of leakage current. The circuit **848** may be configured to cancel extraneous currents in the patient side circuit **822** due to capacitive coupling, as described above, as well as other external effects such as, for example, frequency-specific effects (e.g., 60 Hz or other frequency noise from power supplies), path effects, load effects, etc. Instead of being electrically coupled to ground **818**, the cancellation capacitor **840**, as shown in the circuit **848**, may be coupled to an correction control circuit **851**. The circuit **851** may comprise a digital signal processor (DSP) **850** or other processor. The DSP **850** may receive inputs **858** (e.g., via an analog-to-digital converter). The inputs **858** may be values tending to indicate external effects that may cause additional leakage current. Examples of such inputs may be, for example, power supply parameters, load data such as impedance, impedance or other values describing the path from the circuit **848** to the device **104**, etc. Based on the inputs **858**, the DSP **850** may derive a cancellation potential that, when provided to the cancellation capacitor **840**, may cancel patient-side currents due to the external effects. The cancellation potential may be provided, digitally, to digital-to-analog converter **852**, which may provide an analog version of the cancellation potential to the cancellation capacitor **840**. Accordingly, the voltage drop across the cancellation capacitor **840** may be a function of the inverse drive signal, present across the second secondary winding **846** and the cancellation potential found by the circuit **851**.

[0221] The circuit **848** is shown with the active cancellation transformer **832** omitted and the capacitor **840** and second secondary winding **846** in the configuration of the circuit **844**. It will be appreciated, however, that the correction control circuit **851** may be utilized in any of the configurations described herein (e.g., **820**, **842**, **844**, etc.). For example, the correction control circuit **851** may be substituted for ground **818** in any of the circuits **820**, **842**, **844**.

[0222] FIG. **39** illustrated an embodiment of a circuit **860** that may be implemented by the generator **102** to provide cancellation of leakage current. According to the circuit **860**, the cancellation capacitor **840** may be connected between the primary winding **828** of the isolation transformer **826** and the output line **823** (e.g., the common output line). In this way, the inverse of the drive signal may appear across the cancellation capacitor **840**, bringing about a similar leakage current cancellation effect to those described above.

[0223] FIG. **40** illustrates another embodiment of a circuit **862** that may be implemented by the generator **102** to provide cancellation of leakage current. The circuit **862** may be similar to the circuit **860** with the exception that the cancellation capacitor may be connected between the output line **823** (e.g., the common output line) and two additional capacitors **864**, **866**. Capacitor **864** may be connected between the cancellation capacitor **840** and the primary winding **828** of the isolation transformer **826**. Capacitor **866**

maybe connected between the cancellation capacitor **840** and ground **818**. The combination of the capacitors **864**, **866** may provide a radio frequency (RF) path to ground that may enhance the RF performance of the generator **102** (e.g., by decreasing electromagnetic emissions).

[0224] A surgical generator, such as the generator **102** schematically illustrated in FIG. **10**, for example, may be electrically coupled to a variety of surgical instruments. The surgical instruments may include, for example, both RF-based instruments and ultrasonic-based devices. FIG. **41** illustrates a receptacle and connector interface in accordance with one non-limiting embodiment. In one embodiment, the interface comprises a receptacle assembly **902** and a connector assembly **920**. The connector assembly **920** may be electrically coupled to the distal end of a cable **921** that is ultimately connected to a handheld surgical instrument, for example. FIG. **59** illustrates a surgical generator **1050** in accordance with one non-limiting embodiment. The surgical generator **1050** may comprise a surgical generator body **1052** that generally includes the outer shell of the generator. The surgical body **1052** may define an aperture **1054** for receiving a receptacle assembly, such as the receptacle assembly **1058** illustrated in FIG. **59**. Referring now to FIGS. **41** and **59**, the receptacle assembly **902** may comprise a seal **906** to generally prevent fluid ingress into the surgical generator **1050** by way of the aperture **1054**. In one embodiment, the seal **906** is an epoxy seal.

[0225] FIG. **42** is an exploded side view of the receptacle assembly **902** in accordance with one non-limiting embodiment. The receptacle assembly **902** may include a variety of components, such as a magnet **912**, for example. The receptacle assembly **902** may also comprise a plurality of sockets **908** that may be arranged in a generally circular formation, or any other suitable formation. FIG. **48** is an enlarged view of a socket **908** in accordance with one non-limiting embodiment. In one embodiment, the socket **908** is bifurcated and the receptacle assembly **902** includes nine bifurcated sockets **908**, while greater or few sockets may be utilized in other embodiments. Each of the sockets **908** may define an inner cavity **910** for receiving electrically conductive pins, as discussed in more detail below. In some embodiments, various sockets **908** will be mounted within the receptacle assembly **902** at different elevations such that certain sockets are contacted prior to other sockets when a connector assembly is inserted into the receptacle assembly.

[0226] FIG. **43** is an exploded side view of the connector assembly **920** in accordance with one non-limiting embodiment. The connector assembly **920** may comprise, for example, a connector body **922** that includes an insertion portion **924** that is sized to be received by the receptacle assembly **902**, as described in more detail below. The connector assembly **920** may comprise a variety of other components, such as a ferrous pin **926**, a circuit board **928**, and a plurality of electrically conductive pins **930**. As shown in FIG. **54**, the ferrous pin **926** may be cylindrical. In other embodiments, the ferrous pin **926** may be other shapes, such as rectangular, for example. The ferrous pin **926** may be steel, iron, or any other magnetically compatible material that is attracted to magnetic fields or that may be magnetizable. The ferrous pin **926** may also have a shoulder **927**, or other type of laterally extending feature. Referring now to FIG. **55**, the electrical conductive pins **930** may be affixed to and extend from the circuit board **928**. The circuit board **928** may also include device identification circuitry, such as the

circuits illustrated in FIGS. 33E-33G, for example. Thus, in various embodiments, the circuit board 928 may carry EEPROM, resistors, or any other electrical components. In some embodiments, portions of the circuit board 928 may be potted, or otherwise encapsulated, to improve the sterility of the surgical device and assist in water resistance.

[0227] Referring again to FIG. 43, the connector assembly 920 may also include a strain relief member 932. As shown in FIG. 56, the strain relief member 932 generally accepts cable loading to prevent that loading from being applied to the circuit board 928 and/or the sockets 908. In some embodiments, the strain relief member 932 may include an alignment notch 934 to aid in assembly. Referring again to FIG. 43, the connector assembly 920 may also include a boot 936 that is coupled to the connector body 922. FIG. 57 illustrates the boot 936 in accordance with one non-limiting embodiment. The boot 936 may generally serve as bend relief for an associated cable and assist in sealing the connector assembly 920. In some embodiments, the boot 936 may snap onto the connector body 922. For autoclave applications, the boot 936 may be an overmolded component. In other embodiments, other attachment techniques may be used, such as adhesives or spin welding, for example.

[0228] FIG. 44 is a perspective view of the receptacle assembly 902 shown in FIG. 41. FIG. 45 is an exploded perspective view of the receptacle assembly 902. FIG. 46 is a front elevation view of the receptacle assembly 902. FIG. 47 is a side elevation view of the receptacle assembly 902. Referring to FIGS. 44-47, the receptacle assembly 902 may comprise a flange 950. The flange 950 may have an inner wall 952 and an outer wall 954. Spanning the inner wall 952 and the outer wall 954 is a flange surface 956. The inner wall 952 may include at least one curved portion and at least one linear portion. The inner wall 952 of the flange 950 defines a cavity 960 having a unique geometry. In one embodiment, the cavity 960 is defined by about 270 degrees of a circle and two linear segments that are tangential to the circle and intersect to form an angle  $\ominus$ . In one embodiment, angle  $\ominus$  is about 90 degrees. In one embodiment, a central protruding portion 962 having an outer periphery 964 is positioned in the cavity 960. The central protruding portion 962 may have a central surface 966 that defines a recess 968. The magnet 912 (FIG. 42) may be positioned proximate the recess 968. As illustrated, the sockets 908 may be positioned through apertures 972 defined by the central surface 966 of the central protruding portion 962. In embodiments utilizing a circular arrangement of sockets 908, the magnet 912 may be positioned internal to the circle defined by the sockets. The receptacle body 904 may also define a rear recess 976 (FIG. 47). The rear recess 976 may be sized to receive the seal 906. The flange face 966 may be slanted at an angle  $\beta$  (FIG. 47). As illustrated in FIG. 61, a face of the body 1052 of the surgical generator 1050 also may be slanted at the angle  $\beta$  as well.

[0229] FIG. 49 is a perspective view of the connector assembly 920 and FIG. 50 is an exploded perspective view of the connector assembly 920. FIG. 51 is a side elevation view of the connector body 922 with FIGS. 52 and 53 illustrating perspective views of the distal and proximal ends, respectively, of the connector body 922. Referring now to FIGS. 49-53, connector body 922 may have a flange 980. The flange 980 may comprise at least one curved portion and at least one linear portion.

[0230] The adapter assemblies 1002 and 1004 may comprise substantially the similar components that are contained by the connector body 922 (FIG. 50). For example, the adapter assemblies 1002 and 1004 may each house a circuit board with device identification circuitry. The adapter assemblies 1002 and 1004 may also each house one of a ferrous pin and a magnet to aid in the connection with the surgical generator. An outer wall 982 of the flange 980 may generally be shaped similarly to the inner wall 952 of the receptacle assembly 902 (FIG. 46). An inner wall 984 of the flange 980 may be shaped similarly to the outer periphery 964 of the central protruding portion 962. The connector body 922 may also have a wall 988 that includes a plurality of apertures 990. The apertures 990 may be sized to receive the electrically conductive pins 930 and the ferrous pin 926. In one embodiment, the shoulder 927 of the ferrous pin 926 is sized so that it can not pass through the aperture 990. In some embodiments, the ferrous pin 926 may be able to translate with respect to the wall 988. When assembled, the shoulder 927 of the ferrous pin 926 may be positioned intermediate the wall 988 and the circuit board 928. The ferrous pin 926 may be positioned such that it encounters the magnetic field of the magnet 912 when the connector assembly 920 is inserted into the receptacle assembly 902. In some embodiments, a proper connection will be denoted by an audible click when the ferrous pin 926 translates to the wall 988 and strikes the magnet 912. As is to be appreciated, various components may be positioned intermediate the ferrous pin 926 and the magnet 912, such as a washer, for example, to reduce incidental wear to the interfacing components. Additionally, in some embodiments the magnet 912 may be coupled to the connector assembly 920 and the ferrous pin 926 may be coupled to the receptacle assembly 902.

[0231] FIG. 58 illustrates two adaptor assemblies 1002 and 1004 in accordance with various non-limiting embodiments. The adaptor assemblies 1002 and 1004 allow of connector assemblies having various geometries to be electrically coupled to a receptacle assembly of a surgical generator. Adaptor assembly 1002 is configured to accommodate a surgical instrument having connector assembly 1006 and adaptor assembly 1004 is configured to accommodate a surgical instrument having a connector assembly 1008. In one embodiment, the connector assembly 1006 is associated with an RF-based surgical device via a cable 1060 and the connector assembly 1008 is associated with an ultrasonic-based device via a cable 1062. As is to be appreciated, other embodiments of adaptor assemblies may accommodate surgical instruments having connector assemblies different than those illustrated in FIG. 58. FIG. 59 illustrates the adaptor assembly 1002 after being inserted into the receptacle assembly 1058 of a surgical generator 1050 in accordance with one non-limiting embodiment. FIG. 60 illustrates the connector assembly 1006 after being inserted into the adaptor assembly 1002 and therefore electrically coupled to the surgical generator 1050. Similarly, FIG. 61 illustrates the adaptor assembly 1004 after being inserted into the receptacle assembly 1058 of a surgical generator 1050 in accordance with one non-limiting embodiment. FIG. 62 illustrates the connector assembly 1008 after being inserted into the adaptor assembly 1004. Accordingly, while connector assemblies 1006 and 1008 each having different geometries, both may be used with the surgical generator 1050.

[0232] Referring to FIGS. 58-62, in one embodiment, the adaptor assembly 1002 has a distal portion 1010 that comprises a flange 1012. The flange 1012 is configured to be inserted into the receptacle assembly 1058 of the surgical instrument 1050 and may be similar to the flange 980 illustrated in FIG. 52, for example. Any number of electrically conductive pins, or other connection components, may be positioned in the distal portion to engage the receptacle assembly 1058. In one embodiment, the adaptor assembly 1002 also has a proximal portion 1014 that defines a cavity 1016. The cavity 1016 may be configured to accept a particular connector assembly, such as connector assembly 1006. As is to be appreciated, the proximal portion 1014 may be configured appropriately based on the type of connector assembly with which it will be used. In one embodiment, the adaptor assembly 1006 has a distal portion 1020 that comprises a flange 1022. The flange 1022 is configured to be inserted into the receptacle assembly 1058 of the surgical instrument 1050 and may be similar to the flange 980 illustrated in FIG. 52, for example. The adaptor assembly 1004 also has a proximal portion 1024 that defines a cavity 1026. In the illustrated embodiment, the central portion 1028 is positioned in the cavity 1026 and is configured to accept the connector assembly 1008.

[0233] FIG. 63 illustrates a perspective view of a back panel 1100 of a generator 1102 in accordance with one non-limiting embodiment. The generator 1102 may be similar to generator 102 illustrated in FIG. 10, for example. The back panel 1100 may comprise various input and/or output ports 1104. The back panel 1100 may also comprise an electronic paper display device 1106. The electronic paper display device 1106 may be based on electrophoresis in which an electromagnetic field is applied to a conductive material such that the conductive material has mobility. Micro particles having conductivity are distributed between thin-type flexible substrates, and positions of the micro particles (or toner particles) are changed due to the change of the polarities of an electromagnetic field, whereby data is displayed. The technical approach to realize the electronic paper may be accomplished using any suitable technique, such as liquid crystals, organic electro luminescence (EL), reflective film reflection-type display, electrophoresis, twist balls, or mechanical reflection-type display, for example. Generally, electrophoresis is a phenomenon in which, when particles are suspended in a medium (i.e., a dispersion medium), the particles are electrically charged, and, when an electric field is applied to the charged particles, the particles move to an electrode having opposite charge through the dispersion medium. Further discussion regarding electronic paper display devices may be found in U.S. Pat. No. 7,751,115 entitled ELECTRONIC PAPER DISPLAY DEVICE, MANUFACTURING METHOD AND DRIVING METHOD THEREOF, the entirety of which is incorporated by reference.

[0234] FIG. 64 illustrates the back panel 1100 illustrated in FIG. 63. FIGS. 65 and 66 provide enlarged views of the back panel 1100. Referring to FIGS. 64-66, the electronic paper display device 1106 may display a variety of information, such as a serial number, a part number, patent numbers, warning labels, port identifiers, instructions, vendor information, service information, manufacturer information, operational information, or any other type of information. In one embodiment, the information displayed on the electronic paper display device 1106 may be changed or updated

through connecting a computing device to a communication port (e.g., a USB port) of the generator 1102.

[0235] As shown in FIG. 66, in some embodiments, the back panel 1100 may comprise an interactive portion 1108. In one embodiment, the interactive portion 1108 allows a user to input information to the generator 1102 using input devices, such as buttons 1110. The interactive portion 1108 may also display information that is simultaneously displayed on a front panel (not shown) of the generator 1102.

[0236] In a surgical procedure utilizing an ultrasonic surgical device, such as the ultrasonic surgical device 104, the end effector 126 transmits ultrasonic energy to tissue brought into contact with the end effector 126 to realize cutting and sealing action. The application of ultrasonic energy in this manner may cause localized heating of the tissue. Monitoring and controlling such heating may be desirable to minimize unintended tissue damage and/or to optimize the effectiveness of the cutting and sealing action. Direct measurement of ultrasonic heating requires temperature sensing devices in or near the end effector 126. Although sensor-based measurements of ultrasonic heating is technically feasible, design complexity and other considerations may make direct measurement impractical. Various embodiments of the generator 102 may address this problem by generating an estimate of temperature or heating resulting from an application of ultrasonic energy.

[0237] In particular, one embodiment of the generator 102 may implement an artificial neural network to estimate ultrasonic heating based on a number of input variables 1218. Artificial neural networks are mathematical models that learn complex, nonlinear relationships between inputs and outputs based on exposure to known input and output patterns, a process commonly referred to as “training.” An artificial neural network may comprise a network of simple processing units, or nodes, connected together to perform data processing tasks. The structure of an artificial neural network may be somewhat analogous to the structure of biological neural networks in the brain. When an artificial neural network is presented with an input data pattern, it produces an output pattern. An artificial neural network may be trained for a specific processing task by presentation of large amounts of training data. In this way, the artificial neural network may modify its structure by changing the “strength” of communication between nodes to improve its performance on the training data.

[0238] FIG. 67 illustrates one embodiment of an artificial neural network 1200 for generating an estimated temperature  $T_{est}$  resulting from an application of ultrasonic energy using an ultrasonic surgical device, such as the ultrasonic surgical device 104. In certain embodiments, the neural network may be implemented in the processor 174 and/or the programmable logic device 166 of the generator 102. The neural network 1200 may comprise an input layer 1202, one or more nodes 1204 defining a hidden layer 1206, and one or more nodes 1208 defining an output layer 1210. For the sake of clarity, only one hidden layer 1206 is shown. In certain embodiments, the neural network 1200 may comprise one or more additional hidden layers in a cascaded arrangement, with each additional hidden layer having a number of nodes 1204 that may be equal to or different from the number of nodes 1204 in the hidden layer 1206.

[0239] Each node 1204, 1208 in the layers 1202, 1210 may include one or more weight values  $w$  1212, a bias value  $b$  1214, and a transform function  $f$  1216. In FIG. 67, the use

of different subscripts for these values and functions is intended to illustrate that each of these values and functions may be different from the other values and functions. The input layer 1202 comprises one or more input variables  $p$  1218, with each node 1204 of the hidden layer 1206 receiving as input at least one of the input variables  $p$  1218. As shown in FIG. 67, for example, each node 1204 may receive all of the input variables  $p$  1218. In other embodiments, less than all of the input variables  $p$  1218 may be received by a node 1204. Each input variable  $p$  1218 received by a particular node 1204 is weighted by a corresponding weight value  $w$  1212, then added to any other similarly weighted input variables  $p$  1218, and to the bias value  $b$  1214. The transform function  $f$  1216 of the node 1204 is then applied to the resulting sum to generate the node's output. In FIG. 67, for example, the output of node 1204-1 may be given as  $f_1(n_1)$ , where  $n_1 = (w_{1,1}p_1 + w_{1,2}p_2 + \dots + w_{1,j}p_j) + b_1$ .

[0240] A particular node 1208 of the output layer 1210 may receive an output from one or more of the nodes 1204 of the hidden layer 1206 (e.g., each node 1208 receives outputs  $f_1(\bullet)$ ,  $f_2(\bullet)$ ,  $\dots$ ,  $f_i(\bullet)$ ) from respective nodes 1204-1, 1204-2,  $\dots$ , 1204- $i$  in FIG. 67), with each received output being weighted by a corresponding weight value  $w$  1212 and subsequently added to any other similarly weighted received outputs, and to a bias value  $b$  1214. The transform function  $f$  1216 of the node 1208 is then applied to the resulting sum to generate the node's output, which corresponds to an output of the neural network 1200 (e.g., the estimated temperature  $T_{est}$  in the embodiment of FIG. 67). Although the embodiment of the neural network 1200 in FIG. 67 comprises only one node 1208 in the output layer 1210, in other embodiments the neural network 1200 may comprise more than one output, in which case the output layer 1210 may comprise multiple nodes 1208.

[0241] In certain embodiments, the transform function  $f$  1216 of a node 1204, 1208 may be a nonlinear transfer function. In one embodiment, for example, one or more of the transform functions  $f$  1216 may be a sigmoid function. In other embodiments, the transform functions  $f$  1216 may include a tangent sigmoid, a hyperbolic tangent sigmoid, a logarithmic sigmoid, a linear transfer function, a saturated linear transfer function, a radial basis transfer function, or some other type of transfer function. The transform function  $f$  1216 of a particular node 1204, 1208 may be the same as, or different from, a transform function  $f$  1216 in another node 1204, 1208.

[0242] In certain embodiments, the input variables  $p$  1218 received by the nodes 1204 of the hidden layer 1206 may represent, for example, signals and/or other quantities or conditions known or believed to have an effect on the temperature or heating resulting from an application of ultrasonic energy. Such variables may comprise, for example, one or more of: drive voltage output by the generator 102, drive current output by the generator 102, drive frequency of the generator output 102, drive power output by the generator 102, drive energy output by the generator 102, impedance of the ultrasonic transducer 114, and time duration over which ultrasonic energy is applied. Additionally, one or more of the input variables  $p$  1218 may be unrelated to outputs of the generator 102 and may comprise, for example, characteristics of the end effector 126 (e.g., blade tip size, geometry, and/or material) and a particular type of tissue targeted by the ultrasonic energy.

[0243] The neural network 1200 may be trained (e.g., by changing or varying the weight values  $w$  1212, the bias values  $b$  1214, and the transform functions  $f$  1216) such that its output (e.g., estimated temperature  $T_{est}$  in the embodiment of FIG. 67) suitably approximates a measured dependency of the output for known values of the input variables  $p$  1218. Training may be performed, for example, by supplying known sets of input variables  $p$  1218, comparing output of the neural network 1200 to measured outputs corresponding to the known sets of input variables  $p$  1218, and modifying the weight values  $w$  1212, the bias values  $b$  1214, and/or the transform functions  $f$  1216 until the error between the outputs of the neural network 1200 and the corresponding measured outputs is below a predetermined error level. For example, the neural network 1200 may be trained until the mean square error is below a predetermined error threshold. In certain embodiments, aspects of the training process may be implemented by the neural network 1200 (e.g., by propagating errors back through the network 1200 to adaptively adjust the weight values  $w$  1212 and/or the bias values  $b$  1214).

[0244] FIG. 68 illustrates a comparison between estimated temperature values  $T_{est}$  and measured temperature values  $T_m$  for an implementation of one embodiment of the neural network 1200. The neural network 1200 used to generate  $T_{est}$  in FIG. 68 comprised six input variables  $p$  1218: drive voltage, drive current, drive frequency, drive power, impedance of the ultrasonic transducer, and time duration over which ultrasonic energy was applied. The hidden layer 1206 comprised 25 nodes, and the output layer 1210 comprised a single node 1208. Training data was generated based on 13 applications of ultrasonic energy to carotid vessels. Actual temperature ( $T_m$ ) was determined based on IR measurements over a 250-sample range for varying values of the input variables  $p$  1218, with estimated temperatures  $T_{est}$  being generated by the neural network 1200 based on corresponding values of the input variables  $p$  1218. The data shown in FIG. 68 was generated on a run that was excluded from the training data. The estimated temperatures  $T_{est}$  demonstrate a reasonably accurate approximation of the measured temperatures  $T_m$  in the region of 110-190° F. It is believed that inconsistencies in estimated temperatures  $T_{est}$  appearing in certain regions, such as the region following 110° F., may be minimized or reduced by implementing additional neural networks specific to those regions. Additionally, inconsistencies in the data that may skew the trained output of the neural network 1200 may be identified and programmed in as special cases to further improve performance.

[0245] In certain embodiments, when the estimated temperature exceeds a user-defined temperature threshold  $T_{th}$ , the generator 102 may be configured to control the application of ultrasonic energy such that the estimated temperature  $T_{est}$  is maintained at or below the temperature threshold  $T_{th}$ . For example, in embodiments in which the drive current is an input variable  $p$  1218 to the neural network 1200, the drive current may be treated as a control variable and modulated to minimize or reduce the difference between  $T_{est}$  and  $T_{th}$ . Such embodiments may be implemented using a feedback control algorithm (e.g., a PID control algorithm), with  $T_{th}$  being input to the control algorithm as a setpoint,  $T_{est}$  being input to the algorithm as process variable feedback, and drive current corresponding to the controlled output of the algorithm. In cases where the drive current



serves as the control variable, suitable variations in drive current value should be represented in the sets of input variables **p 1218** used to train the neural network **1200**. In particular, the effectiveness of drive current as a control variable may be reduced if the training data reflects constant drive current values, as the neural network **1200** may reduce the weight values **w 1212** associated with drive current due to its apparent lack of effect on temperature. It will be appreciated that input variables **p 1218** other than drive current (e.g., drive voltage) may be used to minimize or reduce the difference between  $T_{est}$  and  $T_{th}$ .

**[0246]** According to various embodiments, the generator **102** may provide power to a tissue bite according to one or more power curves. A power curve may define a relationship between power delivered to the tissue and the impedance of the tissue. For example as the impedance of the tissue changes (e.g., increases) during coagulation, the power provided by the generator **102** may also change (e.g., decrease) according to the applied power curve.

**[0247]** Different power curves may be particularly suited, or ill-suited, to different types and/or sizes of tissue bites. Aggressive power curves (e.g., power curves calling for high power levels) may be suited for large tissue bites. When applied to smaller tissue bites, such as small vessels, more aggressive power curves may lead to exterior searing. Exterior searing may reduce the coagulation/weld quality at the exterior and can also prevent complete coagulation of interior portions of the tissue. Similarly, less aggressive power curves may fail to achieve hemostasis when applied to larger tissue bites (e.g., larger bundles).

**[0248]** FIG. 69 illustrates one embodiment of a chart **1300** showing example power curves **1306**, **1308**, **1310**. The chart **1300** comprises an impedance axis **1302** illustrating increasing potential tissue impedances from left to right. A power axis **1304** illustrates increasing power from down to up. Each of the power curves **1306**, **1308**, **1310** may define a set of power levels, on the power axis **1304**, corresponding to a plurality of potential sensed tissue impedances, in the impedance axis **1302**. In general, power curves may take different shapes, and this is illustrated in FIG. 69. Power curve **1306** is shown with a step-wise shape, while power curves **1308**, **1310** are shown with curved shapes. It will be appreciated that power curves utilized by various embodiments may take any usable continuous or non-continuous shape. The rate of power delivery or aggressiveness of a power curve may be indicated by its position on the chart **1300**. For example, power curves that deliver higher power for a given tissue impedance may be considered more aggressive. Accordingly, between two power curves, the curve positioned highest on the power axis **1304** may be the more aggressive. It will be appreciated that some power curves may overlap.

**[0249]** The aggressiveness of two power curves may be compared according to any suitable method. For example, a first power curve may be considered more aggressive than a second power curve over a given range of potential tissue impedances if the first power curve has a higher delivered power corresponding to at least half of the range of potential tissue impedances. Also, for example, a first power curve may be considered more aggressive than a second power curve over a given range of potential tissue impedances if the area under the first curve over the range is larger than the area under the second curve over the range. Equivalently, when power curves are expressed discretely, a first power

curve may be considered more aggressive than a second power curve over a given set of potential tissue impedances if the sum of the power values for the first power curve over the set of potential tissue impedances is greater than the sum of the power values for the second power curve over the set of potential tissue impedances.

**[0250]** According to various embodiments, the power curve shifting algorithms described herein may be used with any kind of surgical device (e.g., ultrasonic device **104**, electrosurgical device **106**). In embodiments utilizing an ultrasonic device **104**, tissue impedance readings may be taken utilizing electrodes **157**, **159**. With an electrosurgical device, such as **106**, tissue impedance readings may be taken utilizing first and second electrodes **177**, **179**.

**[0251]** In some embodiments, an electrosurgical device **104** may comprise a positive temperature coefficient (PTC) material positioned between one or both of the electrodes **177**, **179** and the tissue bite. The PTC material may have an impedance profile that remains relatively low and relatively constant until it reaches a threshold or trigger temperature, at which point the impedance of the PTC material may increase. In use, the PTC material may be placed in contact with the tissue while power is applied. The trigger temperature of the PTC material may be selected such that it corresponds to a tissue temperature indicating the completion of welding or coagulation. Accordingly, as a welding or coagulation process is completed, the impedance of the PTC material may increase, bringing about a corresponding decrease in power actually provided to the tissue.

**[0252]** It will be appreciated that during the coagulation or welding process, tissue impedance may generally increase. In some embodiments, tissue impedance may display a sudden impedance increase indicating successful coagulation. The increase may be due to physiological changes in the tissue, a PTC material reaching its trigger threshold, etc., and may occur at any point in the coagulation process. The amount of energy that may be required to bring about the sudden impedance increase may be related to the thermal mass of the tissue being acted upon. The thermal mass of any given tissue bite, in turn, may be related to the type and amount of tissue in the bite.

**[0253]** Various embodiments may utilize this sudden increase in tissue impedance to select an appropriate power curve for a given tissue bite. For example, the generator **102** may select and apply successively more aggressive power curves until the tissue impedance reaches an impedance threshold indicating that the sudden increase has occurred. For example, reaching the impedance threshold may indicate that coagulation is progressing appropriately with the currently applied power curve. The impedance threshold may be a tissue impedance value, a rate of change of tissue impedance, and/or a combination of impedance and rate of change. For example, the impedance threshold may be met when a certain impedance value and/or rate of change are observed. According to various embodiments, different power curves may have different impedance thresholds, as described herein.

**[0254]** FIG. 70 illustrates one embodiment of a process flow **1330** for applying one or more power curves to a tissue bite. Any suitable number of power curves may be used. The power curves may be successively applied in order of aggressiveness until one of the power curves drives the tissue to the impedance threshold. At **1332**, the generator **102** may apply a first power curve. According to various

embodiments, the first power curve may be selected to deliver power at a relatively low rate. For example, the first power curve may be selected to avoid tissue searing with the smallest and most vulnerable expected tissue bites.

[0255] The first power curve may be applied to the tissue in any suitable manner. For example, the generator 102 may generate a drive signal implementing the first power curve. The power curve may be implemented by modulating the power of the drive signal. The power of the drive signal may be modulated in any suitable manner. For example, the voltage and/or current of the signal may be modulated. Also, in various embodiments, the drive signal may be pulsed. For example, the generator 102 may modulate the average power by changing the pulse width, duty cycle, etc. of the drive signal. The drive signal may be provided to the first and second electrodes 177, 179 of the electrosurgical device 106. Also, in some embodiments the drive signal implementing the first power curve may be provided to an ultrasonic generator 114 of the ultrasonic device 104 described above.

[0256] While applying the first power curve, the generator 102 may monitor the total energy provided to the tissue. The impedance of the tissue may be compared to the impedance threshold at one or more energy thresholds. There may be any suitable number of energy thresholds, which may be selected according to any suitable methodology. For example, the energy thresholds may be selected to correspond to known points where different tissue types achieve the impedance threshold. At 1334, the generator 102 may determine whether the total energy delivered to the tissue has met or exceeded a first energy threshold. If the total energy has not yet reached the first energy threshold, the generator 102 may continue to apply the first power curve at 1332.

[0257] If the total energy has reached the first energy threshold, the generator 102 may determine whether the impedance threshold has been reached (1336). As described above, the impedance threshold may be a predetermined rate of impedance change (e.g., increase) a predetermined impedance, or combination of the two. If the impedance threshold is reached, the generator 102 may continue to apply the first power curve at 1332. For example, reaching the impedance threshold in the first power curve may indicate that the aggressiveness of the first power curve is sufficient to bring about suitable coagulation or welding.

[0258] In the event that the impedance threshold is not reached at 1336, the generator 102 may increment to the next most aggressive power curve at 1338 and apply the power curve as the current power curve at 1332. When the next energy threshold is reached at 1334, the generator 102 again may determine whether the impedance threshold is reached at 1336. If it is not reached, the generator 102 may again increment to the next most aggressive power curve at 1338 and deliver that power curve at 1332.

[0259] The process flow 1330 may continue until terminated. For example, the process flow 1330 may be terminated when the impedance threshold is reached at 1336. Upon reaching the impedance threshold, the generator 102 may apply the then-current power curve until coagulation or welding is complete. Also, for example, the process flow 1330 may terminate upon the exhaustion of all available power curves. Any suitable number of power curves may be used. If the most aggressive power curve fails to drive the tissue to the impedance threshold, the generator 102 may continue to apply the most aggressive power curve until the

process is otherwise terminated (e.g., by a clinician or upon reaching a final energy threshold).

[0260] According to various embodiments, the process flow 1330 may continue until the occurrence of a termination threshold. The termination threshold may indicate that coagulation and/or welding is complete. For example, the termination threshold may be based on one or more of tissue impedance, tissue temperature, tissue capacitance, tissue inductance, elapsed time, etc. These may be a single termination threshold or, in various embodiments, different power curves may have different termination thresholds. According to various embodiments, different power curves may utilize different impedance thresholds. For example, the process flow 1330 may transition from a first to a second power curve if the first power curve has failed to drive the tissue to a first tissue impedance threshold and may, subsequently, shift from the second to a third power curve if the second power curve has failed to drive the tissue to a second impedance threshold.

[0261] FIG. 71 illustrates one embodiment of a chart 1380 showing example power curves 1382, 1384, 1386, 1388 that may be used in conjunction with the process flow 1330. Although four power curves 1382, 1384, 1386, 1388 are shown, it will be appreciated that any suitable number of power curves may be utilized. Power curve 1382 may represent the least aggressive power curve and may be applied first. If the impedance threshold is not reached at the first energy threshold, then the generator 102 may provide the second power curve 1384. The other power curves 1386, 1388 may be utilized, as needed, for example in the manner described above.

[0262] As illustrated in FIG. 71, the power curves 1382, 1384, 1386, 1388 are of different shapes. It will be appreciated, however, that some or all of a set of power curves implemented by the process flow 1330 may be of the same shape. FIG. 72 illustrates one embodiment of a chart 1390 showing example common shape power curves 1392, 1394, 1396, 1398 that may be used in conjunction with the process flow of FIG. 70. According to various embodiments, common shape power curves, such as 1392, 1394, 1396, 1398 may be constant multiples of one another. Accordingly, the generator 102 may implement the common shape power curves 1392, 1394, 1396, 1398 by applying different multiples to a single power curve. For example, the curve 1394 may be implemented by multiplying the curve 1392 by a first constant multiplier. The curve 1396 may be generated by multiplying the curve 1392 by a second constant multiplier. Likewise, the curve 1398 may be generated by multiplying the curve 1392 by a third constant multiplier. Accordingly, in various embodiments, the generator 102 may increment to a next most aggressive power curve at 1338 by changing the constant multiplier.

[0263] According to various embodiments, the process flow 1330 may be implemented by a digital device (e.g., a processor, digital signal processor, field programmable gate array (FPGA), etc.) of the generator 102. Examples of such digital devices include, for example, processor 174, programmable logic device 166, processor 190, etc.). FIGS. 73A-73C illustrate process flows describing routines that may be executed by a digital device of the generator 102 to generally implement the process flow 1330 described above. FIG. 73A illustrates one embodiment of a routine 1340 for preparing the generator 102 to act upon a new tissue bite. The activation or start of the new tissue bite may be initiated

at **1342**. At **1344**, the digital device may point to a first power curve. The first power curve, as described above, may be the least aggressive power curve to be implemented as a part of the process flow **1330**. Pointing to the first power curve may comprise pointing to a deterministic formula indicating the first power curve, pointing to a look-up table representing the first power curve, pointing to a first power curve multiplier, etc.

[**0264**] At **1346**, the digital device may reset an impedance threshold flag. As described below, setting the impedance threshold flag may indicate that the impedance threshold has been met. Accordingly, resetting the flag may indicate that the impedance threshold has not been met, as may be appropriate at the outset of the process flow **1330**. At **1348**, the digital device may continue to the next routine **1350**.

[**0265**] FIG. 73B illustrates one embodiment of a routine **1350** that may be performed by the digital device to monitor tissue impedance. At **1352**, load or tissue impedance may be measured. Tissue impedance may be measured according to any suitable method and utilizing any suitable hardware. For example, according to various embodiments, tissue impedance may be calculated according to Ohm's law utilizing the current and voltage provided to the tissue. At **1354**, the digital device may calculate a rate of change of the impedance. The impedance rate of change may likewise be calculated according to any suitable manner. For example, the digital device may maintain prior values of tissue impedance and calculate a rate of change by comparing a current tissue impedance value or values with the prior values. Also, it will be appreciated that the routine **1350** assumes that the impedance threshold is a rate of change. In embodiments where the impedance threshold is a value, **1354** may be omitted. If the tissue impedance rate of change (or impedance itself) is greater than the threshold (**1356**), then the impedance threshold flag may be set (**1358**). The digital device may continue to the next routing at **1360**.

[**0266**] FIG. 73C illustrates one embodiment of a routine **1362** that may be performed by the digital device to provide one or more power curves to a tissue bite. At **1364**, power may be delivered to the tissue, for example, as described above with respect to **1334** of FIG. 70. The digital device may direct the delivery of the power curve, for example, by applying the power curve to find a corresponding power for each sensed tissue impedance, modulating the corresponding power onto a drive signal provided to the first and second electrodes **177**, **179**, the transducer **114**, etc.

[**0267**] At **1366**, the digital device may calculate the total accumulated energy delivered to the tissue. For example, the digital device may monitor the total time of power curve delivery and the power delivered at each time. Total energy may be calculated from these values. At **1368**, the digital device may determine whether the total energy is greater than or equal to a next energy threshold, for example, similar to the manner described above with respect to **1334** of FIG. 70. If the next energy threshold is not met, the current power curve may continue to be applied at **1378** and **1364**.

[**0268**] If the next energy threshold is met at **1368**, then at **1370**, the digital device may determine whether the impedance threshold flag is set. The state of the impedance threshold flag may indicate whether the impedance threshold has been met. For example, the impedance threshold flag may have been set by the routine **1350** if the impedance threshold has been met. If the impedance flag is not set (e.g., the impedance threshold is not met), then the digital device

may determine, at **1372**, whether any more aggressive power curves remain to be implemented. If so, the digital device may point the routine **1362** to the next, more aggressive power curve at **1374**. The routine **1362** may continue (**1378**) to deliver power according to the new power curve at **1364**. If all available power curves have been applied, then the digital device may disable calculating and checking of accumulated energy for the remainder of the tissue operation at **1376**.

[**0269**] If the impedance flag is set at **1370** (e.g., the impedance threshold has been met), then the digital device may disable calculating and checking of accumulated energy for the remainder of the tissue operation at **1376**. It will be appreciated that, in some embodiments, accumulated energy calculation may be continued, while **1370**, **1372**, **1374**, and **1376** may be discontinued. For example, the generator **102** and/or digital device may implement an automated shut-off when accumulated energy reaches a predetermined value.

[**0270**] FIG. 74 illustrates one embodiment of a process flow **1400** for applying one or more power curves to a tissue bite. For example, the process flow **1400** may be implemented by the generator **102** (e.g., the digital device of the generator **102**). At **1402**, the generator **102** may deliver a power curve to the tissue. The power curve may be derived by applying a multiplier to a first power curve. At **1404**, the generator **102** may determine if the impedance threshold has been met. If the impedance threshold has not been met, the generator **102** may increase the multiplier as a function of the total applied energy. This may have the effect of increasing the aggressiveness of the applied power curve. It will be appreciated that the multiplier may be increased periodically or continuously. For example, the generator **102** may check the impedance threshold (**1404**) and increase the multiplier (**1406**) at a predetermined periodic interval. In various embodiments, the generator **102** may continuously check the impedance threshold (**1404**) and increase the multiplier (**1406**). Increasing the multiplier as a function of total applied energy may be accomplished in any suitable manner. For example, the generator **102** may apply a deterministic equation that receives total received energy as input and provides a corresponding multiplier value as output. Also, for example, the generator **102** may store a look-up table that comprises a list of potential values for total applied energy and corresponding multiplier values. According to various embodiments, the generator **102** may provide a pulsed drive signal to tissue (e.g., via one of the surgical devices **104**, **106**). According to various embodiments, when the impedance threshold is met, the multiplier may be held constant. The generator **102** may continue to apply power, for example, until a termination threshold is reached. The termination threshold may be constant, or may depend on the final value of the multiplier.

[**0271**] In some embodiments utilizing a pulsed drive signal, the generator **102** may apply one or more composite load curves to the drive signal, and ultimately to the tissue. Composite load curves, like other power curves described herein, may define a level of power to be delivered to the tissue as a function of a measured tissue property or properties (e.g., impedance). Composite load curves may, additionally, define pulse characteristics, such as pulse width, in terms of the measured tissue properties.

[**0272**] FIG. 75 illustrates one embodiment of a block diagram **1450** describing the selection and application of composite load curves by the generator **102**. It will be

appreciated that the block diagram 1450 may be implemented with any suitable type of generator or surgical device. According to various embodiments, the block diagram 1450 may be implemented utilizing an electrosurgical device, such as the device 106 described above with respect to FIGS. 4-7. Also, in various embodiments, the block diagram 1450 may be implemented with an ultrasonic surgical device, such as the surgical device 104 described above with respect to FIGS. 2-3. In some embodiments, the block diagram 1450 may be utilized with a surgical device having cutting as well as coagulating capabilities. For example, an RF surgical device, such as the device 106, may comprise a cutting edge, such as the blade 175 for severing tissue either before or during coagulation.

[0273] Referring back to FIG. 75, an algorithm 1452 may be executed, for example by a digital device of the generator 102 to select and apply composite load curves 1456, 1458, 1460, 1462. The algorithm 1452 may receive a time input from a clock 1454 and may also receive loop input 1472 from sensors 1468. The loop input 1472 may represent properties or characteristics of the tissue that may be utilized in the algorithm 1452 to select and/or apply a composite load curve. Examples of such characteristics may comprise, for example, current, voltage, temperature, reflectivity, force applied to the tissue, resonant frequency, rate of change of resonant frequency, etc. The sensors 1468 may be dedicated sensors (e.g., thermometers, pressure sensors, etc.) or may be software implemented sensors for deriving tissue characteristics based on other system values (e.g., for observing and/or calculating voltage, current, tissue temperature, etc., based on the drive signal). The algorithm 1452 may select one of the composite load curves 1456, 1458, 1460, 1462 to apply, for example based on the loop input 1472 and/or the time input from the clock 1454. Although four composite load curves are shown, it will be appreciated that any suitable number of composite load curves may be used.

[0274] The algorithm 1452 may apply a selected composite load curve in any suitable manner. For example, the algorithm 1452 may use the selected composite load curve to calculate a power level and one or more pulse characteristics based on tissue impedance (e.g., currently measured tissue impedance may be a part of, or may be derived from, the loop input) or resonant frequency characteristics of an ultrasonic device 104. Examples of pulse characteristics that may be determined based on tissue impedance according to a composite load curve may include pulse width, ramp time, and off time.

[0275] At set point 1464, the derived power and pulse characteristics may be applied to the drive signal. In various embodiments, a feedback loop 1474 may be implemented to allow for more accurate modulation of the drive signal. At the output of the set point 1464, the drive signal may be provided to an amplifier 1466, which may provide suitable amplification. The amplified drive signal may be provided to a load 1470 (e.g., via sensors 1468). The load 1470 may comprise the tissue, the surgical device 104, 106, and/or any cable electrically coupling the generator 102 with the surgical device 104, 106 (e.g., cables 112, 128).

[0276] FIG. 76 illustrates shows a process flow illustrating one embodiment of the algorithm 1452, as implemented by the generator 102 (e.g., by a digital device of the generator 102). The algorithm 1452 may be activated at 1476. It will be appreciated that the algorithm 1452 may be activated in any suitable manner. For example, the algorithm 1452 may

be activated by a clinician upon actuation of the surgical device 104, 106 (e.g., by pulling or otherwise actuating a jaw closure trigger 138, 142, switch, handle, etc.).

[0277] According to various embodiments, the algorithm 1452 may comprise a plurality of regions 1478, 1480, 1482, 1484. Each region may represent a different stage of the cutting and coagulation of a tissue bite. For example, in the first region 1478, the generator 102 may perform an analysis of initial tissue conditions (e.g., impedance). In the second region 1480, the generator 102 may apply energy to the tissue in order to prepare the tissue for cutting. In the third or cut region 1482, the generator 102 may continue to apply energy while the surgical device 104, 106 cuts the tissue (e.g., with the electrosurgical device 106, cutting may be performed by advancing the blade 175). In the fourth or completion region 1484, the generator 102 may apply energy post-cut to complete coagulation.

[0278] Referring now to the first region 1478, the generator 102 may measure any suitable tissue condition or conditions including, for example, current, voltage, temperature, reflectivity, force applied to the tissue, etc. In various embodiments, an initial impedance of the tissue may be measured according to any suitable manner. For example, the generator 102 may modulate the drive signal to provide a known voltage or current to the tissue. Impedance may be derived from the known voltage and the measured current or vice versa. It will be appreciated that tissue impedance may alternately or additionally be measured in any other suitable manner. According to the algorithm 1452, the generator 102 may proceed from the first region 1478 to the second region 1480. In various embodiments, the clinician may end the algorithm 1452 in the first region 1478, for example, by deactivating the generator 102 and/or the surgical device 104, 106. If the clinician terminates the algorithm 1452, RF (and/or ultrasonic) delivery may also be terminated at 1486.

[0279] In the second region 1480, the generator 102 may begin to apply energy to the tissue via the drive signal to prepare the tissue for cutting. Energy may be applied according to the composite load curves 1456, 1458, 1460, 1462, as described below. Applying energy according to the second region 1480 may comprise modulating pulses onto the drive signal according to some or all of the composite load curves 1456, 1458, 1460, 1462. In various embodiments, the composite load curves 1456, 1458, 1460, 1462 may be successively applied in order of aggressiveness (e.g., to accommodate various types of tissue-volume clamped in the instrument jaws).

[0280] The first composite load curve 1456 may be applied first. The generator 102 may apply the first composite load curve 1456 by modulating one or more first composite load curve pulses onto the drive signal. Each first composite load curve pulse may have a power and pulse characteristics determined according to the first composite load curve and considering measured tissue impedance. Measured tissue impedance for the first pulse may be the impedance measured at the first region 1478. In various embodiments, the generator 102 may utilize all or a portion of the first composite load curve pulses to take additional measurements of tissue impedance or resonant frequency. The additional measurements may be used to determine the power and other pulse characteristics of a subsequent pulse or pulses.

[0281] FIG. 77 illustrates one embodiment of a process flow 1488 for generating a first composite load curve pulse. The process flow 1488 may be executed by the generator 102 (e.g., by a digital device of the generator 102), for example, as a part of the algorithm 1452. At 1490, the generator 102 may calculate a pulse width ( $T_{pw}$ ). The pulse width may be determined considering the most recent measured tissue impedance ( $Z$ ) and according to the first composite load curve 1456.

[0282] At 1492, the generator 102 may ramp the power of the drive signal up to a pulse power ( $P_{limit}$ ) over a ramp time ( $t_{ramp}$ ), thereby applying the pulse to the tissue. The pulse power may be determined, again, considering the most recent measured tissue impedance ( $Z$ ) and according to the first composite load curve 1456. The ramp time may be determined according to the composite load curve considering tissue impedance or may be constant (e.g., constant for all first composite load curve pulses, constant for all pulses, etc.). The generator 102 may apply the pulse power to the drive signal in any suitable manner including, for example, modulating a current and/or voltage provided by the drive signal. According to various embodiments, the drive signal may be an alternating current (A/C) signal, and therefore the pulse itself may comprise multiple cycles of the drive signal.

[0283] The drive signal may be held at the pulse power for the pulse width at 1494. At the conclusion of the pulse, the drive signal may be ramped down, at 1496, over a fall time ( $T_{fall}$ ). The fall time may be determined according to the first composite load curve considering tissue impedance, or may be constant (e.g., constant for all first composite load curve pulses, constant for all pulses, etc.). It will be appreciated that, depending on the embodiment, the ramp time and fall time may or may not be considered part of the pulse width. At 1498, the generator 102 may pause for an off time ( $T_{off}$ ). Like the ramp time and fall time, the off time may be determined according to the first composite load curve considering tissue impedance, or may be constant (e.g., constant for all first composite load curve pulses, constant for all pulses, etc.).

[0284] At the completion of the off time, the generator 102 may repeat the process flow 1488 as long as the first composite load curve 1456 is applied. According to various embodiments, the generator 102 may apply the first composite load curve 1456 for a predetermined amount of time. Accordingly, the process flow 1488 may be repeated until the predetermined amount of time has elapsed (e.g., as determined based on the time input received from the clock 1454). Also, in various embodiments, the first composite load curve may be applied for a predetermined number of pulses. Because the applied pulse width varies according to measured tissue impedance, the total time that the first composite load curve is applied may also vary with measured tissue impedance. According to various embodiments, the first composite load curve 1456 (as well as the other composite load curves 1458, 1460, 1462) may specify decreasing pulse widths as tissue impedance increases. Therefore, a higher initial tissue impedance may lead to less time spent in the first composite load curve.

[0285] Upon completion of the first composite load curve 1456, the generator 102 may successively apply the remaining consolidated load curves 1458, 1460, 1462 throughout the application of the second region 1480. Each load curve 1458, 1460, 1462 may be applied in a manner similar to that of the load curve 1456 described above. For example, pulses

according to a current load curve may be generated until the completion of that load curve (e.g., the expiration of a predetermined amount of time or a predetermined number of pulses). The predetermined number of pulses may be the same for each composite load curve 1456, 1458, 1460, 1462 or may be different. According to various embodiments, pulses according to the load curves 1458, 1460, 1462 may be generated in a manner similar to process flow 1488, except that pulse power, pulse width and, in some embodiments, ramp time, fall time, and off time, may be derived according to the current composite load curve.

[0286] The second region 1480 may be terminated upon the occurrence of various events. For example, if the total RF application time has exceeded a timeout time, then the generator 102 may end the tissue operation by terminating RF (and/or ultrasonic) delivery at 1486. Also, various events may cause the generator 102 to transition from the second region 1480 to the third region 1482. For example, the generator 102 may transition to the third region 1482 when the tissue impedance ( $Z$ ) exceeds a threshold tissue impedance ( $Z_{term}$ ) and RF energy has been delivered for at least more than a minimum time ( $T_{start}$ ). The threshold tissue impedance may be an impedance and/or an impedance rate of change indicating that the tissue bite is adequately prepared for cutting by the blade 175.

[0287] According to various embodiments, if the final load curve 1462 is completed in the second region 1480 before completion of the second region 1480, then the final power curve 1462 may be continuously applied, for example, until the tissue impedance threshold is met, the maximum second region time is reached and/or the timeout time is reached. Also, it will be appreciated that, with some tissue cuts, the second region 1480 may be completed before all available consolidated load curves 1456, 1458, 1460, 1462 are executed.

[0288] At the third region 1482, the generator 102 may continue to modulate pulses onto the drive signal. Generally, third region pulses may be modulated onto the drive signal according to any suitable manner including, for example, that described above with reference to the process flow 1488. The power and pulse characteristics of the third region pulses may be determined according to any suitable method and, in various embodiments, may be determined based on the composite load curve that was being executed at the completion of the second region 1480 (the current load curve). According to various embodiments, the current load curve may be utilized to determine the pulse power of third region pulses, while the pulse characteristics (e.g., pulse width, ramp time, fall time, off time, etc.) may be constant regardless of composite load curve. In some embodiments, the third region 1482 may utilize a third-region-specific composite load curve that may be one of the load curves 1456, 1458, 1460, 1462 utilized in the second region 1480, or may be a different composite load curve (not shown).

[0289] The generator 102 may continue to execute the third region 1482 until receiving an indication that the tissue cut is complete. In embodiments utilizing surgical implements having a blade, such as 175, the indication may be received when the blade 175 reaches its distal-most position, as shown in FIG. 6. This may trip a knife limit sensor (not shown) indicating that the blade 175 has reached the end of its throw. Upon receiving the indication that the tissue cut is complete, the generator 102 may continue to the fourth region 1484. It will also be appreciated that, in some

embodiments, the generator **102** may transition from the third region **1482** directly to RF (and/or ultrasonic) termination at **1486**, for example, if the timeout time has been reached.

[0290] In the fourth region **1484**, the generator **102** may provide an energy profile designed to complete coagulation of the now-cut tissue. For example, according to various embodiments, the generator **102** may provide a predetermined number of pulses. The pulses may be provided in a manner similar to that described above with respect to the process flow **1488**. The power and pulse characteristics of the pulses may be determined according to any suitable manner. For example, power and pulse characteristics of the fourth region pulses may be determined based on the current composite load curve, the third-region-specific load curve, or a fourth-region-specific composite load curve. In some embodiments, power may be determined based on the current composite load curve, while pulse characteristics may be fourth region-specific. Also, according to various embodiments, the power and pulse characteristics of fourth region pulses may be determined independent of the current composite load curve.

[0291] FIG. **78** illustrates one embodiment of a pulse timing diagram **1474** illustrating an example application of the algorithm **1452** by the generator **102** (e.g., by a digital device of the generator **102**). A first region pulse **1502** is shown in the first region **1478**. The first region pulse **1502** may be utilized, as described, to measure an initial tissue impedance. At the completion of the first region pulse (**1509**), second region **1480** may begin with second region pulses **1504** applied. The second region pulses **1504** may be applied according to the various composite load curves **1456**, **1458**, **1460**, **1462**, for example, as described herein. In the example diagram **1474**, the second region **1480** concludes at **1510** when the tissue reaches the threshold impedance ( $Z_{term}$ ). The third region **1482** is then implemented, with third region pulses **1506**, as described above, applied until a knife limit signal is received at **1512**. At that point, the fourth region **1484** may commence, with fourth region pulses **1508**, as described above, applied until cycle completion at **1514**.

[0292] According to various embodiments, the generator **102** may implement a user interface in conjunction with the algorithm **1452**. For example, the user interface may indicate the current region of the algorithm. The user interface may be implemented visually and/or audibly. For example, the generator **102** may comprise a speaker for generating audible tones or other audible indication. At least one audible indication may correspond to the second region **1480**. The third and fourth regions **1482**, **1484** may also have region-specific audible indications. According to various embodiments, the first region **1478** may have a region-specific audible indication as well. According to various embodiments, the audible indications may comprise pulsed tones generated by the generator **102**. The frequency of the tones and/or the pitch of the tones themselves may indicate the current region. In addition to, or instead of, the audible indications, the generator **102** may also provide a visual indication of the current region (e.g., on output device **147**). It will be appreciated that the clinician may utilize the described user interface to properly use the generator **102** and associated surgical devices **104**, **106**. For example, the indication of the second region **1480** may let the clinician know that tissue treatment has begun. The indication of the

third region **1482** may let the clinician know that the tissue is ready for the cutting operation. The indication of the fourth region **1484** may let the clinician know that the cutting operation is complete. The cessation of the indication and/or a final indication may indicate that the total cutting/coagulation operation is complete.

[0293] FIG. **79** illustrates a graphical representation of drive signal voltage, current and power according to an example load curve **1520**. In the chart **1520**, drive signal voltage is represented by line **1522**, drive signal current is represented by line **1524** and drive signal power is represented by line **1526**. Pulse width is not indicated in FIG. **79**. In various embodiments, the values for voltage **1522**, current **1524** and power **1526** indicated by the graph **1520** may represent possible values within a single pulse. Accordingly, the load curve **1520** may be expressed as a composite load curve by adding a curve (not shown) indicating a pulse width as a function of tissue impedance or another tissue condition. As shown for the load curve **1520**, the maximum voltage **1522** is 100 Volts Root Mean Square (RMS), the maximum current is 3 Amps RMS and the maximum power is 135 Watts RMS.

[0294] FIGS. **80-85** illustrate graphical representations of various example composite load curves **1530**, **1532**, **1534**, **1536**, **1538**, **1540**. Each of the composite load curves **1530**, **1532**, **1534**, **1536**, **1538**, **1540** may indicate both pulse power and pulse width in terms of measured tissue impedance. The composite load curves **1530**, **1532**, **1534**, **1536** may be implemented either in isolation or as part of a pattern of successively more aggressive composite load curves, as described above with respect to the algorithm **1452**.

[0295] FIG. **80** illustrates a graphical representation of a first example composite load curve **1530**. The composite load curve **1530** may have a maximum pulse power of 45 Watts RMS and a maximum pulse width of 0.35 seconds. In FIG. **80**, the power as a function of tissue impedance is indicated by **1542**, while the pulse width as a function of tissue impedance is indicated by **1544**. Table 1 below illustrates values for the composite load curve **1530** for tissue impedances from  $0\Omega$  to  $475\Omega$ .

TABLE 1

Load, Ohms	V Lim, RMS	I Lim, RMS	P Lim, W	PW, Sec
0-24	85	1.4	45	0.35
25-49	85	1.4	45	0.35
50-74	85	1.4	45	0.3
75-99	85	1.4	45	0.3
100-124	85	1.4	45	0.25
125-149	85	1.4	45	0.25
150-174	85	1.4	45	0.2
175-199	85	1.4	45	0.2
200-224	85	1.4	44	0.15
225-249	85	1.4	40	0.15
250-274	85	1.4	36	0.1
275-299	85	0.31	24	0.1
300-324	85	0.28	22	0.1
325-349	85	0.26	20	0.1
350-374	85	0.25	19	0.1
375-399	85	0.22	18	0.1
400-424	85	0.21	17	0.1
425-449	85	0.2	16	0.1
450-475	85	0.19	15	0.1
475+	85	0.15	14	0.1

In various embodiments, the composite load curve **1530** may be suited to smaller surgical devices and/or smaller tissue bites.

[0296] FIG. **81** illustrates a graphical representation of a second example composite load curve **1532**. The composite load curve **1532** may have a maximum pulse power of 45 Watts RMS and a maximum pulse width of 0.5 seconds. In FIG. **81**, the power as a function of tissue impedance is indicated by **1546**, while the pulse width as a function of tissue impedance is indicated by **1548**. Table 2 below illustrates values for the composite load curve **1532** for tissue impedances from 0Ω to 475Ω.

TABLE 2

Load, Ohms	V Lim, RMS	I Lim, RMS	P Lim, W	PW, Sec
0-24	85	3	45	0.5
25-49	85	2	45	0.5
50-74	85	1.4	45	0.5
75-99	85	1.1	45	0.5
100-124	85	0.9	45	0.5
125-149	85	0.7	45	0.5
150-174	85	0.55	45	0.5
175-199	85	0.48	45	0.5
200-224	85	0.42	32	0.5
225-249	85	0.38	28	0.5
250-274	85	0.33	26	0.3
275-299	85	0.31	24	0.3
300-324	85	0.28	22	0.25
325-349	85	0.26	20	0.25
350-374	85	0.25	19	0.25
375-399	85	0.22	18	0.25
400-424	85	0.21	17	0.25
425-449	85	0.2	16	0.25
450-475	85	0.19	15	0.25
475+	85	0.15	14	0.25

The composite load curve **1532** may be targeted at small, single vessel tissue bites and, according to various embodiments, may be a first composite power curve applied in region two **1480**.

[0297] FIG. **82** illustrates a graphical representation of a third example composite load curve **1534**. The composite load curve **1534** may have a maximum pulse power of 60 Watts RMS and a maximum pulse width of 2 seconds. In FIG. **82**, the power as a function of tissue impedance is indicated by **1550**, while the pulse width as a function of tissue impedance is indicated by **1552**. Table 3 below illustrates values for the composite load curve **1534** for tissue impedances from 0Ω to 475Ω.

TABLE 3

Load, Ohms	V Lim, RMS	I Lim, RMS	P Lim, W	PW, Sec
0-24	85	3	60	2
25-49	85	3	60	2
50-74	100	3	60	2
75-99	100	3	60	2
100-124	100	3	60	2
125-149	100	3	60	2
150-174	100	3	55	0.5
175-199	100	3	50	0.5
200-224	85	0.42	32	0.3
225-249	85	0.38	28	0.3
250-274	85	0.33	26	0.3
275-299	85	0.31	24	0.3
300-324	85	0.28	22	0.25

TABLE 3-continued

Load, Ohms	V Lim, RMS	I Lim, RMS	P Lim, W	PW, Sec
325-349	85	0.26	20	0.25
350-374	85	0.25	19	0.25
375-399	85	0.22	18	0.25
400-424	85	0.21	17	0.25
425-449	85	0.2	16	0.25
450-475	85	0.19	15	0.25
475+	85	0.15	14	0.25

The composite load curve **1534** may be more aggressive than the prior curve **1532** by virtue of its generally higher power. The composite load curve **1534** may also, initially, have higher pulse widths than the prior curve **1532**, although the pulse widths of the composite load curve **1534** may begin to drop at just 150Ω. According to various embodiments, the composite load curve **1534** may be utilized in the algorithm **1452** as a load curve implemented sequentially after the composite load curve **1532**.

[0298] FIG. **83** illustrates a graphical representation of a fourth example composite load curve **1536**. The composite load curve **1536** may have a maximum pulse power of 90 Watts RMS and a maximum pulse width of 2 seconds. In FIG. **83**, the power as a function of tissue impedance is indicated by **1554**, while the pulse width as a function of tissue impedance is indicated by **1556**. Table 4 below illustrates values for the composite load curve **1536** for tissue impedances from 0Ω to 475Ω.

TABLE 4

Load, Ohms	V Lim, RMS	I Lim, RMS	P Lim, W	PW, Sec
0-24	85	3	90	2
25-49	85	3	90	2
50-74	100	3	90	2
75-99	100	3	90	2
100-124	100	3	80	2
125-149	100	3	65	2
150-174	100	3	55	0.5
175-199	100	3	50	0.5
200-224	85	0.42	32	0.3
225-249	85	0.38	28	0.3
250-274	85	0.33	26	0.3
275-299	85	0.31	24	0.3
300-324	85	0.28	22	0.25
325-349	85	0.26	20	0.25
350-374	85	0.25	19	0.25
375-399	85	0.22	18	0.25
400-424	85	0.21	17	0.25
425-449	85	0.2	16	0.25
450-475	85	0.19	15	0.25
475+	85	0.15	14	0.25

The composite load curve **1536** may, again, be more aggressive than the prior curve **1534** and, therefore, may be implemented sequentially after the curve **1534** in the algorithm **1452**. Also, according to various embodiments, the composite load curve **1536** maybe suited to larger tissue bundles.

[0299] FIG. **84** illustrates a graphical representation of a fifth example composite load curve **1538**. The composite load curve **1538** may have a maximum pulse power of 135 Watts RMS and a maximum pulse width of 2 seconds. In FIG. **84**, the power as a function of tissue impedance is indicated by **1558**, while the pulse width as a function of

tissue impedance is indicated by **1560**. Table 5 below illustrates values for the composite load curve **1538** for tissue impedances from 0Ω to 475Ω.

TABLE 5

Load, Ohms	V Lim, RMS	I Lim, RMS	P Lim, W	PW, Sec
0-24	85	3	135	2
25-49	85	3	135	2
50-74	100	3	135	2
75-99	100	3	100	2
100-124	100	3	80	2
125-149	100	3	65	2
150-174	100	3	55	0.5
175-199	100	3	50	0.5
200-224	85	0.42	32	0.3
225-249	85	0.38	28	0.3
250-274	85	0.33	26	0.3
275-299	85	0.31	24	0.3
300-324	85	0.28	22	0.25
325-349	85	0.26	20	0.25
350-374	85	0.25	19	0.25
375-399	85	0.22	18	0.25
400-424	85	0.21	17	0.25
425-449	85	0.2	16	0.25
450-475	85	0.19	15	0.25
475+	85	0.15	14	0.25

The composite load curve **1538** may be used sequentially after the prior curve **1536** in the algorithm **1452**.

[0300] FIG. **85** illustrates a graphical representation of a sixth example composite load curve **1540**. The composite load curve **1540** may have a maximum pulse power of 90 Watts RMS and a maximum pulse width of 2 seconds. In FIG. **85**, the power as a function of tissue impedance is indicated by **1562**, while the pulse width as a function of tissue impedance is indicated by **1564**. Table 6 below illustrates values for the composite load curve **1540** for tissue impedances from 0Ω to 475Ω.

TABLE 6

Load, Ohms	V Lim, RMS	I Lim, RMS	P Lim, W	PW, Sec
0-24	85	3	90	2
25-49	85	3	90	2
50-74	100	3	90	2
75-99	100	3	90	2
100-124	100	3	80	2
125-149	100	3	65	2
150-174	100	3	55	0.5
175-199	100	3	50	0.5
200-224	85	0.42	32	0.3
225-249	85	0.38	28	0.3
250-274	85	0.33	26	0.3
275-299	85	0.31	24	0.3
300-324	85	0.28	22	0.25
325-349	85	0.26	20	0.25
350-374	85	0.25	19	0.25
375-399	85	0.22	18	0.25
400-424	85	0.21	17	0.25
425-449	85	0.2	16	0.25
450-475	85	0.19	15	0.25
475+	85	0.15	14	0.25

The composite power curve **1540** is less aggressive than the prior power curve **1538**. According to various embodiments, the composite power curve **1540** may be implemented in the algorithm **1452** sequentially after the curve **1538**. Also, in some embodiments, the composite power curve **1540** may

be implemented in the algorithm **1452** as a third or fourth region-specific composite power curve.

[0301] As described above, the various composite power curves used in the algorithm **1452** may each be implemented for a predetermined number of pulses. Table 7 below illustrates the number of pulses per composite power curve for an example embodiment utilizing the power curves **1532**, **1534**, **1536**, **1538**, and **1540** sequentially in the algorithm **1452**.

TABLE 7

Composite Load Curve	Number of Pulses
1532	4
1534	2
1536	2
1538	8
1540	n/a

The last composite power curve **1540** is shown without a corresponding number of pulses. For example, the composite power curve **1540** may be implemented until the clinician terminates the operation, until the timeout time is reached, until the threshold tissue impedance is reached, etc.

[0302] According to various embodiments, the generator **102** may provide power to a tissue bite in a manner that brings about a desired value of other tissue parameters. FIG. **86** illustrates one embodiment of a block diagram **1570** describing the application of an algorithm **1572** for maintaining a constant tissue impedance rate of change. The algorithm **1572** may be implemented by the generator **102** (e.g., by a digital device of the generator **102**). For example, the algorithm **1572** may be utilized by the generator **102** to modulate the drive signal. Sensors **1574** may sense a tissue condition, such as tissue impedance and/or a rate of change of tissue impedance. The sensors **1574** may be hardware sensors or, in various embodiments may be software implemented sensors. For example, the sensors **1574** may calculate tissue impedance based on measured drive signal current and voltage. The drive signal may be provided by the generator **102** to the cable/implant/load **1576**, which may be the electrical combination of the tissue, the surgical device **104,106** and a cable **112, 128** electrically coupling the generator **102** to the device **104, 106**.

[0303] The generator **102**, by implementing the algorithm **1572**, may monitor the impedance of the tissue or load including, for example, the rate of change of impedance. The generator **102** may modulate one or more of the voltage, current and/or power provided via the drive signal to maintain the rate of change of tissue impedance at a predetermined constant value. Also, according to various embodiments, the generator **102** may maintain the rate of change of the tissue impedance at above a minimum impedance rate of change.

[0304] It will be appreciated that the algorithm **1572** may be implemented in conjunction with various other algorithms described herein. For example, according to various embodiments, the generator **102** may sequentially modulate the tissue impedance to different, increasingly aggressive rates similar to the method **1330** described herein with reference to FIG. **70** herein. For example, a first impedance rate of change may be maintained until the total energy delivered to the tissue exceeds a predetermined energy threshold. At the energy threshold, if tissue conditions have



not reached a predetermined level (e.g., a predetermined tissue impedance), then the generator **102** may utilize the drive signal to drive the tissue to a second, higher impedance rate of change. Also, in various embodiments, tissue impedance rates of change may be used in a manner similar to that described above with respect to composite load curves. For example, instead of utilizing plurality of composite load curves, the algorithm **1452** of FIG. **75** may call for applying a plurality of rates of tissue impedance change. Each rate of tissue impedance change may be maintained for a predetermined amount of time and/or a predetermined number of pulses. The rates may be successively applied in order of value (e.g., rates may successively increase). In some embodiments, however, the driven rates of tissue impedance change may peak, and then be reduced.

**[0305]** Although the various embodiments of the devices have been described herein in connection with certain disclosed embodiments, many modifications and variations to those embodiments may be implemented. For example, different types of end effectors may be employed. Also, where materials are disclosed for certain components, other materials may be used. The foregoing description and following claims are intended to cover all such modification and variations.

**[0306]** Any patent, publication, or other disclosure material, in whole or in part, that is said to be incorporated by reference herein is incorporated herein only to the extent that the incorporated materials does not conflict with existing definitions, statements, or other disclosure material set forth in this disclosure. As such, and to the extent necessary, the disclosure as explicitly set forth herein supersedes any conflicting material incorporated herein by reference. Any material, or portion thereof, that is said to be incorporated by reference herein, but which conflicts with existing definitions, statements, or other disclosure material set forth herein will only be incorporated to the extent that no conflict arises between that incorporated material and the existing disclosure material.

We claim:

**1.** A surgical generator for use with at least one surgical instrument, comprising:

a power supply;

an output stage;

an ultrasonic generator module to provide at the output stage an ultrasonic drive signal for driving an ultrasonic surgical device; and

an electrosurgical generator module to provide at the output stage an electrosurgical drive signal for driving an electrosurgical device.

**2.** The surgical generator of claim **1**, wherein the ultrasonic generator module and the electrosurgical generator module are implemented within a common housing.

**3.** The surgical generator of claim **1**, wherein the electrosurgical drive signal for driving the ultrasonic surgical device has a higher root mean square (RMS) voltage than the electrosurgical drive signal for driving the electrosurgical device.

**4.** The surgical generator of claim **3**, wherein the RMS voltage of the ultrasonic drive signal is about 420V RMS.

**5.** The surgical generator of claim **3**, wherein the RMS voltage of the electrosurgical device is about 100V RMS.

**6.** The surgical generator of claim **1**, wherein the output stage comprises:

a power amplifier in communication with the programmable logic device; and

a power transformer in electrical communication with the power amplifier, wherein the power transformer comprises a primary winding and a secondary winding isolated from the first winding.

**7.** The surgical generator of claim **6**, wherein the secondary winding comprises a first end and a second end, and wherein causing the output stage to provide the ultrasonic drive signal comprises causing the ultrasonic drive signal to be present across the secondary winding between the first end and the second end.

**8.** The surgical generator of claim **6**, wherein the secondary winding comprises a first end, a second end and a tap positioned between the first end and the second end, and wherein causing the output stage to provide the electrosurgical drive signal comprises causing the electrosurgical drive signal to be present between the tap and the second end of the secondary winding.

**9.** The surgical generator of claim **1**, wherein at least one of providing the ultrasonic drive signal or providing the electrosurgical drive signal comprises:

recalling a waveform sample from a look-up table; and  
modifying the waveform sample to generate a modified waveform; and

providing the modified waveform to the output stage.

**10.** A surgical generator for use with at least one surgical instrument, the surgical generator comprising:

an output stage; and

at least one programmable logic device to control the output stage, wherein the processor is programmed to:  
cause the output stage to provide an ultrasonic drive signal to drive an ultrasonic surgical device; and  
cause the output stage to provide an electrosurgical drive signal to drive an electrosurgical device.

**11.** The surgical generator of claim **10**, wherein the output stage comprises:

a power amplifier in communication with the programmable logic device; and

a power transformer in electrical communication with the power amplifier, wherein the power transformer comprises a primary winding and a secondary winding isolated from the first winding.

**12.** The surgical generator of claim **11**, wherein the secondary winding comprises a first end and a second end, and wherein causing the output stage to provide the ultrasonic drive signal comprises causing the ultrasonic drive signal to be present across the secondary winding between the first end and the second end.

**13.** The surgical generator of claim **11**, wherein the secondary winding comprises a first end, a second end and a tap positioned between the first end and the second end, and wherein causing the output stage to provide the electrosurgical drive signal comprises causing the electrosurgical drive signal to be present between the tap and the second end of the secondary winding.

**14.** The surgical generator of claim **10**, wherein the at least one programmable logic device comprises a field-programmable gate array (FPGA).

**15.** The surgical generator of claim **10**, wherein the at least one programmable logic device comprises a digital signal processor.

**16.** The surgical generator of claim **10**, wherein causing the output stage to provide at least one of the ultrasonic drive signal or the electrosurgical drive signal comprises:

recalling a waveform sample from a look-up table; and  
modifying the waveform sample to generate a modified waveform; and

providing the modified waveform to the output stage.

**17.** The surgical generator of claim **16**, wherein modifying the waveform sample comprises pre-distorting the waveform sample based on a feedback signal received by the programmable logic device.

**18.** The surgical generator of claim **17**, wherein causing the output stage to provide the ultrasonic drive signal further comprises determining an impedance phase of tissue being treated by at least one of the ultrasonic surgical device and the electrosurgical device, and wherein modifying the waveform sample comprises modifying a frequency of the waveform sample to reduce a difference between the impedance phase and an impedance phase set point.

**19.** The surgical generator of claim **17**, wherein modifying the waveform sample comprises executing a control algorithm.

**20.** The surgical generator of claim **19**, wherein the control algorithm is a proportional-integral-derivative (PID) algorithm.

\* \* \* \* \*