

(No Model.)

W. MASON.
MACHINE FOR BURNISHING HORSESHOES.

No. 523,989.

Patented Aug. 7, 1894.

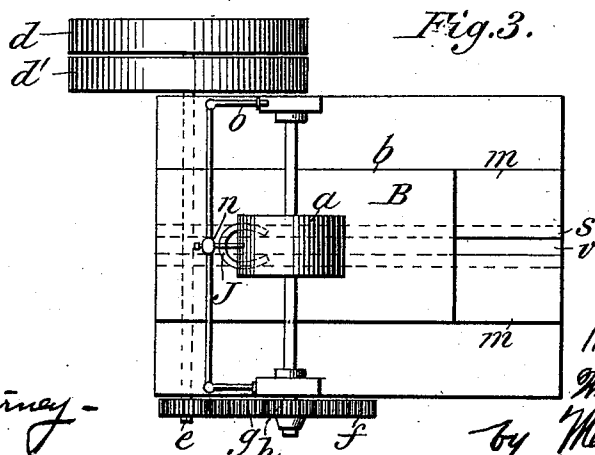
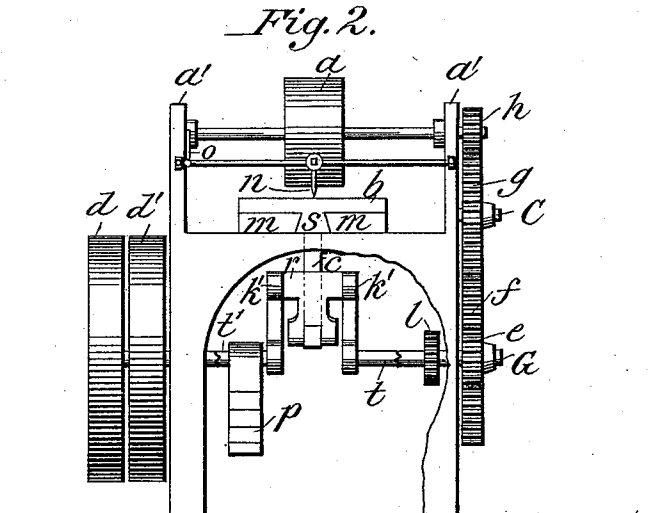
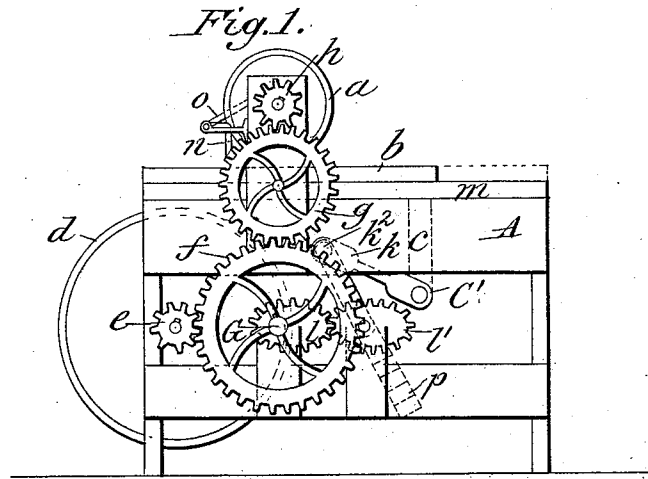

WITNESSES:

A. J. Birney -
M. C. Massie.

INVENTOR:

William Mason
by Mayhew & Co.
Attorney.

UNITED STATES PATENT OFFICE.

WILLIAM MASON, OF PAWTUCKET, RHODE ISLAND.

MACHINE FOR BURNISHING HORSESHOES.

SPECIFICATION forming part of Letters Patent No. 523,989, dated August 7, 1894.

Application filed May 25, 1893. Serial No. 475,527. (No model.)

To all whom it may concern:

Be it known that I, WILLIAM MASON, a citizen of the United States, residing at Pawtucket, in the county of Providence and State of Rhode Island, have invented certain new and useful Improvements in Machines for Burnishing Horseshoes; and I do hereby declare that the following is a full, clear, and exact description of the invention, which will enable others skilled in the art to which it appertains to make and use the same.

The object of my invention is to provide a machine for burnishing horse shoes, and this result I accomplish by the mechanism illustrated in the accompanying drawings, in which—

Figure —1— is a front elevation of the machine one side being broken away; Fig. —2— a longitudinal cross section in elevation, dotted lines showing hidden parts, and Fig. —3— is a top view.

Similar letters refer to similar parts throughout the views.

In Fig. —1— —A— designates a suitable frame of metal or other material strongly mounted upon uprights, the top of the frame being flat and provided near its rear end with uprights —a'— —a'— in which are mounted bearings for a shaft —a²— upon the middle of which is mounted a heavy metal drum —a— revolving with said shaft.

Upon the platform formed by the top of frame a carriage —B— is mounted upon a triangular flange —s— (Figs. 1 and 2) said carriage moving forward and backward upon the platform by means of said flange fitting within the raised tracks —m— —m— constructed upon the same, longitudinal thereto, and passing directly beneath the drum —a—. In the flat upper surface of the carriage at a point near the rear end thereof a depression —J— is made adapted to receive a horse shoe (Fig. —3—).

In Fig. —1— —c— designates a perpendicular arm firmly attached to the under surface of said carriage and extending down through the longitudinal slot —v— made in said platform. At the point —c'— this arm is pivoted to the connecting rod —k— (Fig. —1—) which revolves upon the axis —k²— of the double crank —k'—. The broken, continuous shaft marked —t— —t'— (Fig. —2—) revolves in

bearings mounted in opposite sides of the frame, and is adapted to move the double crank as will hereinafter appear. Upon the section —t— of the shaft is eccentrically mounted the elliptical gear —l'—.

—G— designates a shaft parallel to the continuous shaft —t— —t'—, similarly mounted in bearings in opposite sides of frame.

—l— designates an elliptical gear similar and corresponding to gear —l'— eccentrically mounted upon the shaft —G— in such a manner that its teeth will engage with the teeth of gear —l'—. Upon the end of shaft —G— extending without the side of frame is mounted the large gear —f—.

—g— and —h— designate two of a system of three gears, each engaging with the other respectively, and properly mounted one above the other, the small upper gear —h— being mounted upon the shaft —a²—, the purpose of this system preferably employed by me being to give the requisite speed to the drum —a—.

—d— —d'— represent respectively a loose and tight pulley mounted without the frame in any proper manner. In my machine the pulleys are mounted upon a shaft bearing and revolving in bearings in opposite sides of the frame. Upon the end of this shaft on the end opposite the pulleys is mounted a small gear —e— adapted to engage with and move the large gear —f—.

The method of using my machine is as follows: When the carriage —b— is at the front of the table the horse shoe to be burnished is transferred, when hot, from the bending machine to the mold —J—. When power is applied to the fast pulley —d'— the shaft upon which is mounted the elliptical gear —l— revolves the gear and its teeth engaging with the teeth of elliptical gear —l'— causes the double crank to move the carriage toward the end of the table, and carries the shoe beneath the revolving drum —a—, which burnishes and helps to form up the same. At the end of the platform I have arranged an automatic pick-up marked —n—, the purpose of which is to remove the shoe from the mold when the carriage begins its return movement. This is a device well known to those skilled in this art and needs no description. When the carriage reaches its limit of forward movement

a reciprocal movement to the front of the platform is given to the same by the revolution of the double crank, and to prevent a too rapid return of the same I have attached to the shaft —*l'*— a counter weight —*p*—.

It is to the use of the elliptical gears which in combination with the double crank produce an even reciprocal movement to the carriage that I would draw particular attention, which never previous to my invention have been employed in the particular form and manner shown.

I am aware that burnishing machines have heretofore been employed in which the table is reciprocated at a uniform rate in both directions, and I am also aware that shaping machines have been constructed in which elliptical gears were employed to move the table at a variable speed, but, in the latter class of machines, the elliptical gears were arranged in a horizontal plane, that is to say, with their axes vertical, whereas, in a machine embodying my invention, the elliptical gears have their axes horizontal and themselves rotate in a vertical plane. By this arrangement, all lateral strain on the ways is avoided.

Having thus fully described my invention, what I claim as new, and desire to secure by Letters Patent, is—

In a horse-shoe burnishing machine, a burnishing drum, a drum-shaft on which the drum is mounted, a carriage below the drum provided with a recess, a horizontal crank-shaft below the carriage and provided with a double crank, a counter-weight attached to the crank-shaft opposite the double crank, a connecting rod attached to the double crank and to the carriage, a driving shaft, a driving pinion on the driving shaft, an intermediate shaft, a gear wheel on the intermediate shaft and meshing into the driving pinion, an elliptical gear wheel on the intermediate shaft, a similar gear on the crank-shaft, both elliptical gears being in mesh, and revolving in a vertical plane, an idler gear wheel meshing with the gear wheel on the intermediate shaft, a gear pinion fixed on the drum shaft and meshing into the idler gear wheel, and an automatic pick-up actuated by the drum-shaft, substantially as set forth.

In testimony whereof I have hereunto set my hand in the presence of two subscribing witnesses.

WILLIAM MASON.

In presence of—

CLAUDE J. FARNSWORTH,
EDWARD W. BLODGETT.