

(12) PATENT
(19) AUSTRALIAN PATENT OFFICE

(11) Application No. **AU 199734525 B2**
(10) Patent No. **723493**

(54) Title
transport cradle for a skid-supported helicopter

(51)⁶ International Patent Classification(s)
B64F 001/22

(21) Application No: **199734525** (22) Application Date: **1997 .06 .30**

(87) WIPO No: **WO98/00335**

(30) Priority Data

(31) Number	(32) Date	(33) Country
9613736	1996 .07 .01	GB

(43) Publication Date : **1998 .01 .21**

(43) Publication Journal Date : **1998 .03 .19**

(44) Accepted Journal Date : **2000 .08 .31**

(71) Applicant(s)
Anthony Hancock

(72) Inventor(s)
Anthony Hancock

(74) Agent/Attorney
PHILLIPS ORMONDE and FITZPATRICK, 367 Collins Street, MELBOURNE VIC 3000

(56) Related Art
US 3009711
US 5135346

OPI DATE 21/01/98 APPLN. ID 34525/97
AOJP DATE 19/03/98 PCT NUMBER PCT/GB97/01833



AU9734525

CT)

(51) International Patent Classification ⁶: B64F 1/22	AI	(11) International Publication Number: WO 98/00335
		(43) International Publication Date: 8 January 1998 (08.01.98)
(21) International Application Number: PCT/GB97/01833	(81) Designated States: AL, AM, AT, AU, AZ, BA, BB, BG, BR, BY, CA, CH, CN, CU, CZ, DE, DK, EE, ES, FI, GB, GE, GH, HU, IL, IS, JP, KE, KG, KP, KR, KZ, LC, LK, LR, LS, LT, LU, LV, MD, MG, MK, MN, MW, MX, NO, NZ, PL, PT, RO, RU, SD, SE, SG, SI, SK, SL, TJ, TM, TR, TT, UA, UG, US, UZ, VN, YU, ZW, European patent (AT, BE, CH, DE, DK, ES, FI, FR, GB, GR, IE, IT, LU, MC, NL, PT, SE).	
(22) International Filing Date: 30 June 1997 (30.06.97)		
(30) Priority Data: 9613736.9 1 July 1996 (01.07.96) GB		
(71)(72) Applicant and Inventor: HANCOCK, Anthony [GB/GB]; 99 Harpenden Drive, Hatfield, Doncaster DN7 4HN (GB).	Published <i>With international search report.</i>	
(74) Agent: ORR, William, McLean; Urquhart-Dykes & Lord, Tower House, Merrion Way, Leeds LS2 8PA (GB).		

(54) Title: TRANSPORT CRADLE FOR A SKID-SUPPORTED HELICOPTER

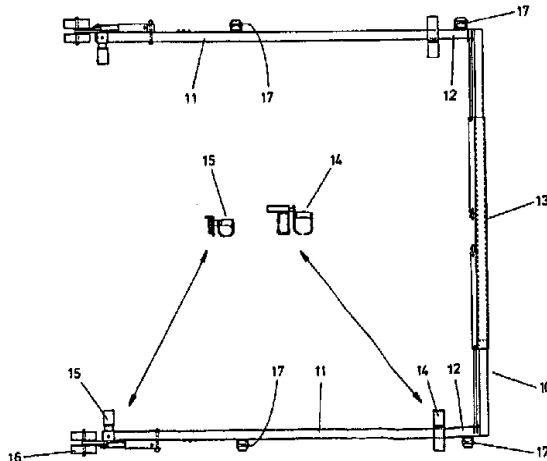

(57) Abstract

A transport cradle for a skid-supported helicopter having a pair of laterally spaced and generally parallel support skids. The transport cradle has a main frame (10) supported by transport wheels (16) and a pair of laterally spaced elongate supports (11) extending generally parallel to each other and forming part of the frame. The supports are each intended to engage and to lift a respective helicopter skid after the cradle has been presented to a helicopter supported on the ground by its skids. The cradle also comprises means (13) for adjusting the spacing apart of the supports to correspond with the spacing apart of the helicopter skids. The cradle also has clamping means (14, 15) provided on each support and operative to engage and clamp the respective skid to the support.

TRANSPORT CRADLE FOR A SKID-SUPPORTED HELICOPTER

This invention relates to a transport cradle for a skid-supported helicopter i.e. a helicopter having a pair of laterally spaced and generally parallel support skids.

In the design and manufacture of helicopters, reduction of weight is of paramount importance, given that the major part of the engine power is utilised to generate a sufficient lifting force by the rotor blades, and therefore any avoidable increase in "dead weight" of the helicopter represents a reduction in potential payload. This is particularly important in military and police applications, where on-board equipment e.g. weaponry and / or surveillance equipment are typical add-on pay loads.

It is therefore common practice to provide many types of helicopters with simple support skids, since this represents a substantial weight saving compared to a wheel-supported undercarriage to support the load of the helicopter on the ground.

However, while a helicopter is of course highly manoeuvrable in the air, it is a particularly awkward craft to handle and manoeuvre on the ground when it is supported by simple skids. Frequently, small helicopters have to be physically man-handled, when they are required to be moved from the place where they have landed e.g. to move the craft into a hanger. This is arduous work, and often is the cause of personal injury.

The invention therefore seeks to provide a transport cradle for a skid-supported helicopter and which is capable of engaging a set of helicopter skids on the ground, and then raising the skids off the ground so that the entire helicopter can be manoeuvred easily over the ground.



According to the invention there is provided a helicopter transport cradle for a skid-supported helicopter having a pair of laterally spaced and generally parallel support skids, the cradle comprising:

- a main frame supported by transport wheels;
- 5 a pair of laterally spaced elongate supports extending generally parallel to each other and forming part of the main frame and each bearing clamping means operable to engage and clamp a respective helicopter skid, after the cradle has been presented to a helicopter supported on the ground by its skids to lift the helicopter, in which the main frame is generally U-shaped as seen in plan and has a cross-member interconnecting
- 10 facing ends of the supports;
 - means for adjusting the spacing apart of the supports to correspond with the spacing apart of the helicopter skids;
 - rotary support elements mounted on the supports and having an axis of rotation parallel to the length of the supports on the ground by the rotary support elements; and
 - 15 a cross member transport wheel arrangement including a power module driving a trolley wheel, in which the trolley wheel is steerable, so that the entire manoeuvring of the cradle can be controlled via the trolley wheel.

Therefore, a transport cradle according to the invention can readily be moved over the ground to a standing helicopter via its transport wheels, and can then be manoeuvred so as to line up the supports alongside the respective skids. The clamping means are then operated to engage and to clamp the skids to the supports, and the cradle can then be moved over the ground via its transport wheels to move the helicopter to a required new position eg inside a hanger.

Preferably, the transport wheels are retractable between a ground engaging position and a raised position, so that when in the raised position any necessary lateral adjustment of the supports can take place to move the supports into close relationship to the respective skids. After completion of the clamping operation, the wheels can be lowered again (thereby lifting the helicopter via its skids), and allowing transport of the helicopter.

- 30 The rotary support elements may be rollers, and may be out of contact with the ground when the transport wheels are lowered, but which engage the ground when the transport wheels are raised.

The clamping means comprise suitable clamping elements which are preferably adjustably mounted on the supports so as to be movable into clamping engagement with



the skids. It is often the case that helicopter skids are not exactly parallel to each other, but "toe-in" to a small extent, and the facility for the clamping elements to be adjusted relative to the support allows any necessary lateral clearance to be taken up as the clamping elements move into clamping engagement with the skids.

5 The cross-member preferably has a transport wheel arrangement which supports the cross-member at a required height above the ground, and the cross-member may be adjustable in height relative to the transport wheel arrangement, to correspond with any adjustment in height of the elongate supports via adjustment of their transport wheels.

10 Thus, for movement of the cradle over the ground, the transport wheels of the elongate supports will be lowered, and the cross-member also will be adjusted to corresponding height above the ground, so that the cradle can be presented to the helicopter skids. Lowering of the supports (by raising of the transport wheels), and corresponding lowering of the cross-member, then allows any necessary lateral adjustment of the supports via ground contact with their rollers. The axes of rotation of
15 the rollers is generally parallel to the longitudinal axes of the supports, to permit necessary lateral adjustment of the supports.

One preferred means of lateral adjustment of the elongate supports comprises a telescopic adjustment incorporated into the cross-member.

20 A preferred embodiment of transport cradle for a skid-supported helicopter will now be described in detail, by way of example only, with reference to the accompanying drawings, in which:

Figure 1 is a schematic and perspective illustration of



the transport cradle being manoeuvred to a position of engagement with a pair of skids of a standing helicopter;

Figure 2 is a plan view of the cradle, and showing it in more detail;

Figure 3 is a side view of one of a pair of parallel elongate support arms of the cradle shown in Figure 2; and

Figure 4 is an end view of a cross-member of the generally U-shaped cradle shown in Figure 2.

Referring now to the drawings, there will be described a preferred embodiment of helicopter transport cradle according to the invention, and as can be seen from the perspective illustration of Figure 1, the cradle is generally U-shaped, seen in plan, and in which a pair of generally parallel elongate support arms of the cradle are presented to a pair of laterally spaced and generally parallel support skids of a helicopter, with each support arm extending alongside, but outwardly of the respective skid.

The cradle is designated generally by reference 10, and the pair of opposed, generally parallel supports are designated by reference 11, being interconnected at their facing ends 12 by a cross-member 13.

The supports 11 are intended each to engage and to lift a respective helicopter skid after the cradle 10 has been presented to the helicopter standing on the ground via its skids.

Means is provided to adjust the spacing apart of the supports 11 to correspond with the spacing apart of the helicopter skids, and in the illustrated embodiment, this is achieved by incorporating a telescopic adjustment in the cross-member 13, which in the illustrated arrangement comprises a pair of ram operated adjuster rods.

Clamping means is provided on each support 11, and operative to engage and to clamp the respective skid to the sport. The clamping means are shown only schematically in Figures 2 and 3, with a larger clamping device 14 being arranged near end 12 of the support 11, and a smaller clamping device 15 near the opposite end.

The transport cradle 10 can be readily moved over the ground to a standing helicopter, and then be manoeuvred so as to line up the supports 11 alongside the helicopter skids. The clamping means 14, 15 are then operated to engage and to clamp the skids to the supports, and the cradle can then be moved over the ground to move the helicopter to a required new position.

The supports 11 are provided with retractable transport wheels 16, and which can move between a ground engaging position and a raised position (as shown in Figure 3). When in the raised position, any necessary lateral adjustment of the supports 11 can take place, to move the supports 11 into close relationship to the respective skids so that the clamping operation can take place. After completion of the clamping operation, the wheels can be lowered (thereby lifting the helicopter via its skids) and allowing transport of the helicopter.

Lateral adjustment of the supports 11 is obtained by providing suitable rotary support elements, which in the illustrated embodiment comprise rollers 17 having axes of rotation extending parallel to the longitudinal axes of the supports 11. Rollers 17 are out of contact with the ground when the transport wheels 16 are lowered, but engage the ground when the transport wheels are raised, to allow lateral adjustment of the supports 11 upon operation of the telescopic adjustment incorporated within the cross-member 13.

The support of the cradle 10 is achieved, for transport over the ground, not only via the transport wheels 16, when in the lowered position, but also by a transport wheel arrangement which supports the cross-member 13. The transport wheel arrangement supporting the cross-member 13 is shown schematically in the perspective illustration of Figure 1.

The transport wheel arrangement supports the cross-member 13 at a required height above the ground, and the cross-member 13 is capable of being adjustable in height relative to the wheel arrangement, to correspond with the height above the ground of the supports 11 via their transport wheels, so that

the cradle can be presented to the helicopter skids. Lowering of the supports 11, by raising the wheels 16, and followed by lowering of the cross member 13, allows lateral adjustment of the supports 11 over the ground via contact with the ground of their rollers 17.

The cradle of the invention may be arranged to be manually manoeuvrable, but preferably it is a self propelled cradle, and this may be achieved by providing a motor-driven trolley wheel module to support the cross-member 13. This may be a battery operated module. The module may have a steerable wheel, so that the entire manoeuvring of the cradle can be controlled via the wheel supported module.

A helicopter transport cradle according to the invention can be utilised as ground handling unit for all types of skid mounted helicopters. It has been designed to give the operator maximum control, with minimum effort, affording maximum protection for both the payload, and the operator.

The power source for the self propelled unit may be a 24 volt DC rechargeable battery, which requires minimal maintenance and overnight charging only.

Drive may be from an electric motor and reduction box, controlled by a combined directional and proportional switch, through an integrated speed control board, enabling the unit to be capable of adjustment from moving from a slow "snail pace" to a fast walking speed of 5 mph.

Lift control may be achieved by electro-hydraulic operating rams, controlled by lever operated directional spool valves.

Steering may be achieved by operating a moving yoke system, giving the operator simple steering movements, with either hand controlling forward and reverse travel. Controlling the direction may be a "point and steer" operation or simple visual reference, and be capable of turning 90° left or right. This will permit turns of 360° to be performed, generally around a centre of gravity of the helicopter in either direction.

The width adjustment of the supports may be hydraulic,

-7-

using a typical telescopic movement, and each support is controlled individually, to bring the support generally alongside the respective skid of the helicopter, regardless of whether it is "toe-in" or "toe-out". The adjustable clamping devices on the supports allow the respective skids to be engaged and firmly clamped to the supports, prior to raising of the supports relative to the ground.

An important aspect of the transport cradle is that it can pick up a helicopter by travelling down both sides of the helicopter, on the outsides of the skids, rather than down the centre. This is done for two reasons.

First of all, from the safety point of view, by approaching and picking up a helicopter in this way, effectively a wheel support is provided at each corner of the skid arrangement. This supports the helicopter with such stability that even quick 90° turns, and sudden directional changes, can be executed without risk of loss of stability (subject to structural surroundings).

Secondly, it gives convenience to the helicopter operator. By using this method, it means that expensive accessories, such as cameras, search lights, belly hooks and weapon cradles can all be catered for, without fear of damage caused by the handling unit, since such accessories are normally supported in-board of the skids. Also, the facility for adjusting the separation of the supports allows the cradle to be used with different designs of helicopters automatically, whilst being in full view of the operator.

7A

Throughout the description and claims of this specification, the word "comprise" and variations of the word, such as "comprising" and "comprises", is not intended to exclude other additives, components, integers or steps.

5

3
2
1

4
5
6
7



WINWORDJANELLE\SPEC\134525.DOC

THE CLAIMS DEFINING THE INVENTION ARE AS FOLLOWS:

1. A helicopter transport cradle for a skid-supported helicopter having a pair of laterally spaced and generally parallel support skids, the cradle comprising:

5 a main frame supported by transport wheels;

a pair of laterally spaced elongate supports extending generally parallel to each other and forming part of the main frame and each bearing clamping means operable to engage and clamp a respective helicopter skid, after the cradle has been presented to a helicopter supported on the ground by its skids to lift the helicopter, in which the main
10 frame is generally U-shaped as seen in plan and has a cross-member interconnecting facing ends of the supports;

means for adjusting the spacing apart of the supports to correspond with the spacing apart of the helicopter skids;

15 rotary support elements mounted on the supports and having an axis of rotation parallel to the length of the supports to allow lateral adjustment of the supports when supported on the ground by the rotary support elements; and

a cross member transport wheel arrangement including a power module driving a trolley wheel, in which the trolley wheel is steerable, so that the entire manoeuvring of the cradle can be controlled via the trolley wheel.

20

2. A cradle as claimed in claim 1, in which the transport wheels are retractable between a ground engaging position and a raised position, so that when in the raised position lateral adjustment of the supports can take place to move the supports into close relationship to the respective skids or to allow lateral movement of
25 the entire cradle.

25

3. A cradle as claimed in claim 2, in which the rotary support elements are out of contact with the ground when the transport wheels are lowered, but engage the ground when the transport wheels are raised.

30

4. A cradle as claimed in any preceding claim, in which the clamping means comprise suitable clamping elements adjustably mounted on the supports so as to be movable into clamping engagement with the skids.



5. A cradle as claimed in claim 1, in which the transport wheels are lowerable and are mounted on the opposite ends of the supports to the cross-member.

6. A cradle as claimed in claim 5, in which the cross-member transport wheel arrangement supports the cross-member at a required height above the ground, and the cross-member is adjustable in height relative to the transport wheel arrangement, to correspond with any adjustment in height of the elongate supports via adjustment of their transport wheels.

7. A cradle as claimed in any preceding claim, in which the means for adjusting the spacing apart of the supports comprises a telescopic adjustment incorporated into the cross-member.

8. A cradle as claimed any preceding claim, in which the transport wheel arrangement of the cross-member is a battery operated arrangement.

9. A transport cradle for a skid supported helicopter substantially as hereinbefore described with reference to the accompanying drawings.

PHILLIPS
ORMONDE &
FITZPATRICK

20 DATED: 2 June, 2000
PHILLIPS ORMONDE & FITZPATRICK
Attorneys for:
ANTHONY HANCOCK

25

30

35



FIG. 1

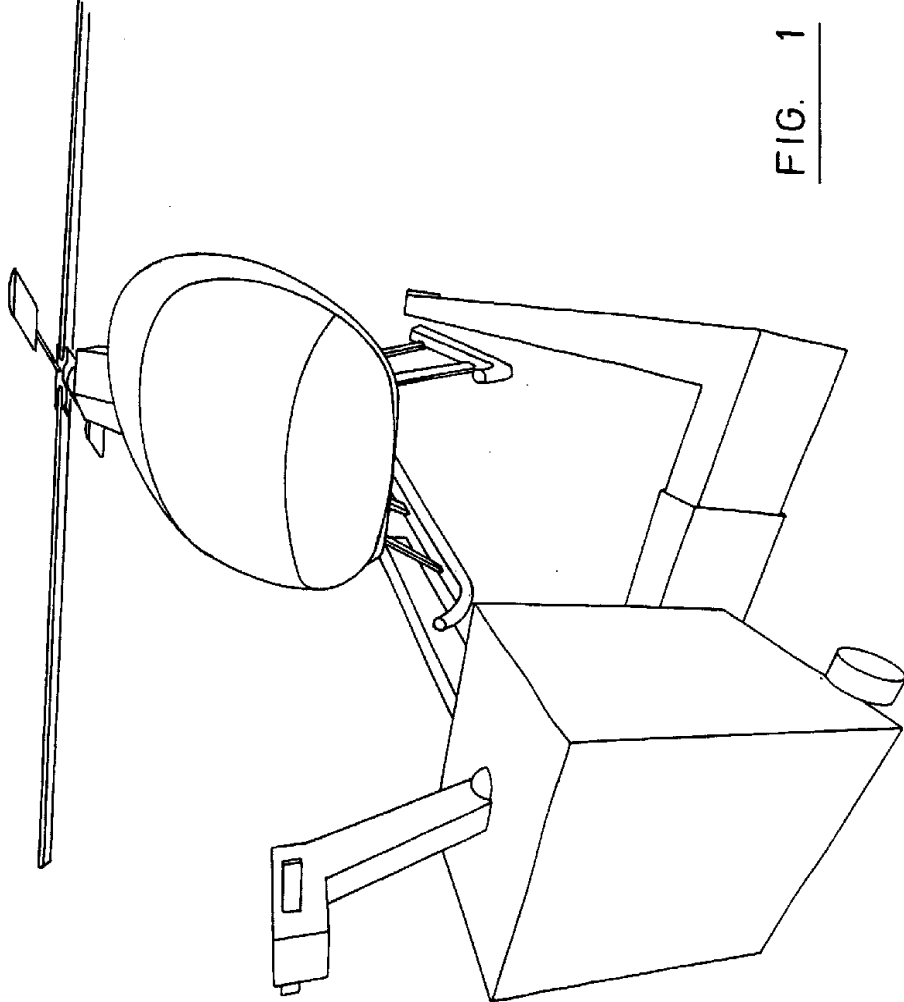

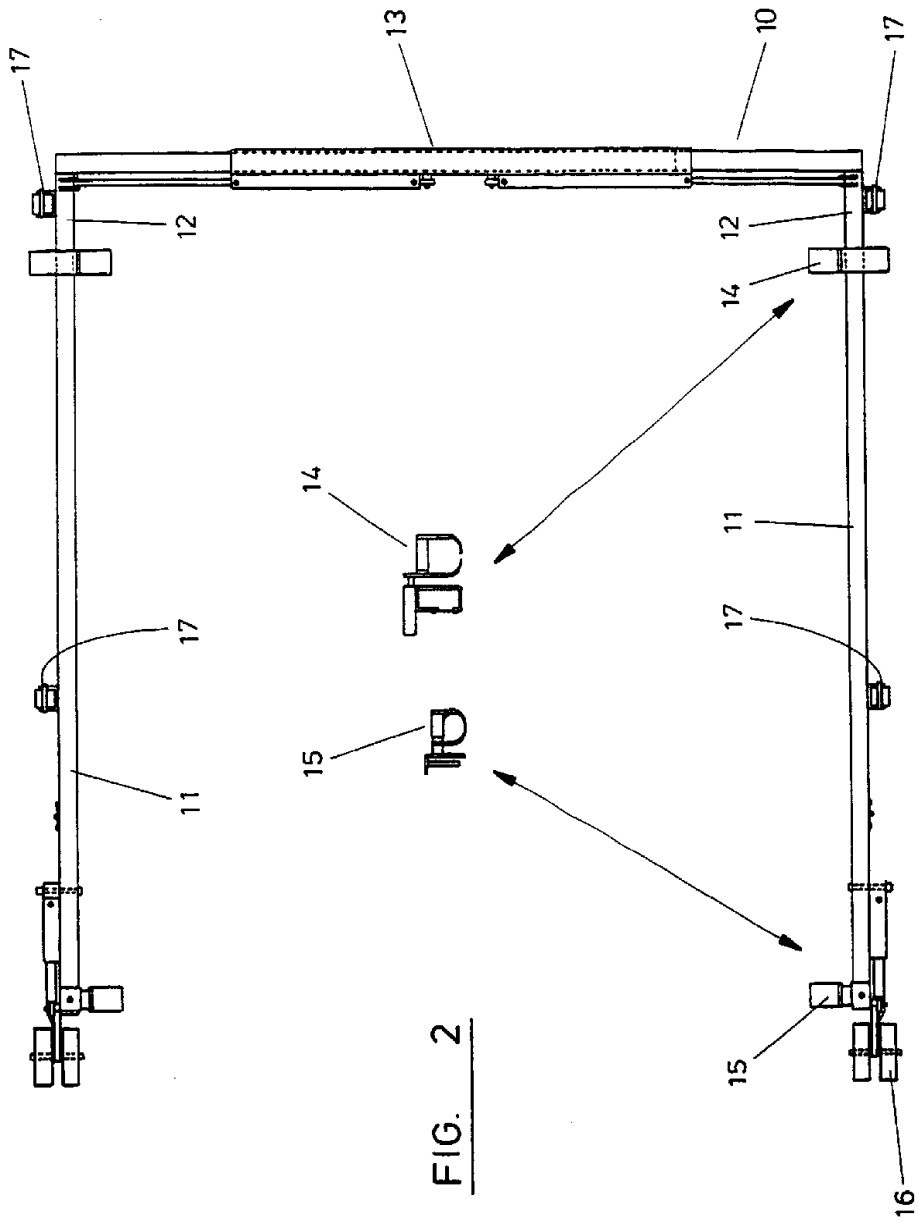

FIG. 2

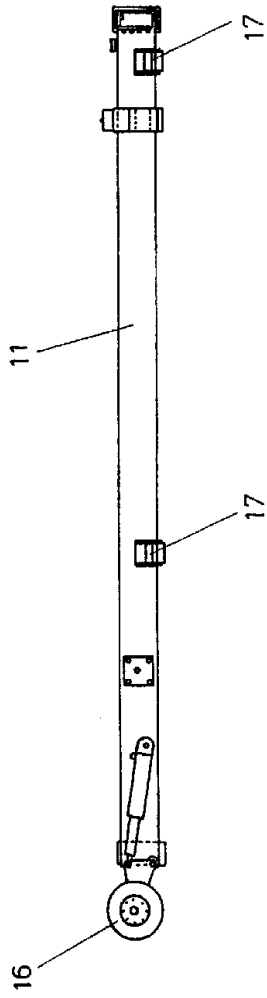

FIG. 3

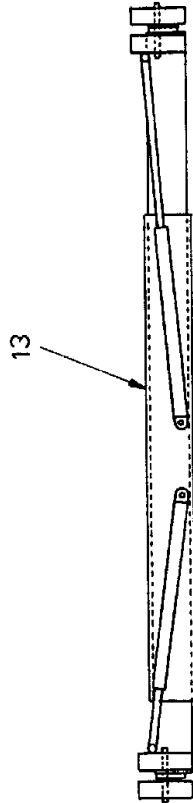

FIG. 4