



- (51) International Patent Classification:  
A24F 47/00 (2006.01)
- (21) International Application Number:  
PCT/IB2017/050293
- (22) International Filing Date:  
19 January 2017 (19.01.2017)
- (25) Filing Language: English
- (26) Publication Language: English
- (30) Priority Data:  
15/002,056 20 January 2016 (20.01.2016) US
- (71) Applicant: RAI STRATEGIC HOLDINGS, INC.  
[US/US]; 401 North Main Street, Winston-Salem, North Carolina 27101 (US).
- (72) Inventor: SUR, Rajesh; 1774 Queen Catherine Lane, Winston-Salem, North Carolina 27106 (US).
- (74) Agent: SPENCE, Andrew T.; Womble Carlyle Sandridge & Rice, LLP, Attn: Patent Docketing, P.O. Box 7037, Atlanta, Georgia 30357-0037 (US).

- (81) Designated States (unless otherwise indicated, for every kind of national protection available): AE, AG, AL, AM, AO, AT, AU, AZ, BA, BB, BG, BH, BN, BR, BW, BY, BZ, CA, CH, CL, CN, CO, CR, CU, CZ, DE, DJ, DK, DM, DO, DZ, EC, EE, EG, ES, FI, GB, GD, GE, GH, GM, GT, HN, HR, HU, ID, IL, IN, IR, IS, JP, KE, KG, KH, KN, KP, KR, KW, KZ, LA, LC, LK, LR, LS, LU, LY, MA, MD, ME, MG, MK, MN, MW, MX, MY, MZ, NA, NG, NI, NO, NZ, OM, PA, PE, PG, PH, PL, PT, QA, RO, RS, RU, RW, SA, SC, SD, SE, SG, SK, SL, SM, ST, SV, SY, TH, TJ, TM, TN, TR, TT, TZ, UA, UG, US, UZ, VC, VN, ZA, ZM, ZW.
- (84) Designated States (unless otherwise indicated, for every kind of regional protection available): ARIPO (BW, GH, GM, KE, LR, LS, MW, MZ, NA, RW, SD, SL, ST, SZ, TZ, UG, ZM, ZW), Eurasian (AM, AZ, BY, KG, KZ, RU, TJ, TM), European (AL, AT, BE, BG, CH, CY, CZ, DE, DK, EE, ES, FI, FR, GB, GR, HR, HU, IE, IS, IT, LT, LU, LV, MC, MK, MT, NL, NO, PL, PT, RO, RS, SE, SI, SK, SM, TR), OAPI (BF, BJ, CF, CG, CI, CM, GA, GN, GQ, GW, KM, ML, MR, NE, SN, TD, TG).

[Continued on next page]

(54) Title: CONTROL FOR AN INDUCTION-BASED AEROSOL DELIVERY DEVICE

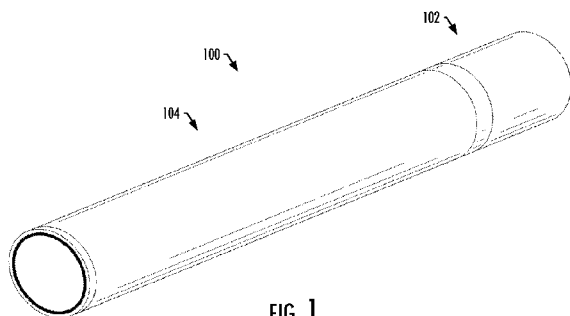

FIG. 1

(57) Abstract: An aerosol delivery device is provided that includes a substrate configured to carry an aerosol precursor composition, and includes an induction transmitter, induction receiver and control component. The induction transmitter is configured to generate an oscillating magnetic field. The induction receiver is positioned in proximity to the substrate, and configured to generate heat when exposed to the oscillating magnetic field and thereby vaporize components of the aerosol precursor composition. The control component is configured to direct current to the induction transmitter to drive the induction transmitter to generate the oscillating magnetic field, with the control component being configured to direct the current according to a zero voltage switching (ZVS) inverter topology.

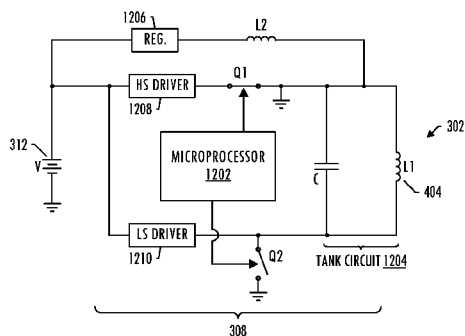

FIG. 12

WO 2017/125878 A1

**Declarations under Rule 4.17:**

- *as to applicant's entitlement to apply for and be granted a patent (Rule 4.17(ii))*
- *as to the applicant's entitlement to claim the priority of the earlier application (Rule 4.17(iii))*

**Published:**

- *with international search report (Art. 21(3))*
- *before the expiration of the time limit for amending the claims and to be republished in the event of receipt of amendments (Rule 48.2(h))*

## CONTROL FOR AN INDUCTION-BASED AEROSOL DELIVERY DEVICE

## TECHNOLOGICAL FIELD

The present disclosure relates to aerosol delivery devices such as electronic cigarettes and heat-not-burn cigarettes, and more particularly to an induction-based aerosol delivery device. The aerosol delivery device may be configured to heat an aerosol precursor composition, which may be made or derived from tobacco or otherwise incorporate tobacco, to form an inhalable substance for human consumption.

5

## BACKGROUND

Many smoking devices have been proposed through the years as improvements upon, or alternatives to, smoking products that require combusting tobacco for use. Many of those devices purportedly have been designed to provide the sensations associated with cigarette, cigar, or pipe smoking, but without delivering considerable quantities of incomplete combustion and pyrolysis products that result from the burning of tobacco. To this end, there have been proposed numerous smoking products, flavor generators, and medicinal inhalers that utilize electrical energy to vaporize or heat a volatile material, or attempt to provide the sensations of cigarette, cigar, or pipe smoking without burning tobacco to a significant degree. See, for example, the various alternative smoking articles, aerosol delivery devices and heat generating sources set forth in the background art described in U.S. Pat. No. 8,881,737 to Collett et al., U.S. Pat. App. Pub. No. 2013/0255702 to Griffith Jr. et al., U.S. Pat. App. Pub. No. 2014/0000638 to Sebastian et al., U.S. Pat. App. Pub. No. 2014/0096781 to Sears et al., U.S. Pat. App. Pub. No. 2014/0096782 to Ampolini et al., and U.S. Pat. App. Pub. No. 2015/0059780 to Davis et al., which are incorporated herein by reference in their entireties. See also, for example, the various implementations of products and heating configurations described in the background sections of U.S. Pat. Nos. 5,388,594 to Counts et al. and 8,079,371 to Robinson et al., which are incorporated by reference in their entireties.

Various implementations of aerosol delivery devices employ an atomizer to produce an aerosol from an aerosol precursor composition. Such atomizers often employ direct resistive heating to produce heat. In this regard, atomizers may include a heating element comprising a coil or other member that produces heat via the electrical resistance associated with the material through which an electrical current is directed. Electrical current is typically directed through the heating element via direct electrical connections such as wires or connectors. However, forming such electrical connections may complicate assembly of the aerosol delivery device and add potential points of failure. Further, in some implementations, the aerosol delivery device may include a control body, which may include a power source, and a cartridge, which may include the atomizer. In these implementations electrical connections between the cartridge and the control body may be required, which may further complicate the design of the aerosol delivery device. Thus, advances with respect to aerosol delivery devices may be desirable.

30

## BRIEF SUMMARY

The present disclosure relates to aerosol delivery devices configured to produce aerosol and which aerosol delivery devices, in some implementations, may be referred to as electronic cigarettes or heat-not-burn cigarettes. As described hereinafter, the aerosol delivery devices may include an induction receiver and an induction transmitter, which may cooperate to form an electrical transformer. The induction transmitter may include a coil configured to create an oscillating magnetic field (e.g., a magnetic field that varies periodically with time) when alternating current is directed therethrough. The induction receiver may be at least partially received within the induction transmitter and may include a conductive material. Thereby, by directing alternating current through the induction transmitter, eddy currents may be generated in the induction receiver via induction. The eddy currents flowing through the resistance of the material defining the induction receiver may heat it by Joule heating. Thereby, the induction receiver, which may define an atomizer, may be wirelessly heated to form an aerosol from an aerosol precursor composition positioned in proximity to the induction receiver. Wireless heating, as used herein, refers to heating that occurs via an atomizer that is not physically electrically connected to the (electrical) power source.

The present disclosure includes, without limitation, the following example implementations.

**Example Implementation 1:** An aerosol delivery device comprising a substrate configured to carry an aerosol precursor composition; an induction transmitter configured to generate an oscillating magnetic field; an induction receiver positioned in proximity to the substrate, and configured to generate heat when exposed to an oscillating magnetic field and thereby vaporize components of the aerosol precursor composition; and a control component configured to direct current to the induction transmitter to drive the induction transmitter to generate the oscillating magnetic field, the control component being configured to direct the current according to a zero voltage switching (ZVS) inverter topology.

**Example Implementation 2:** The aerosol delivery device of any preceding or any subsequent example implementation, or any combination thereof, wherein the aerosol delivery device further comprises a power source including a supercapacitor, wherein the control component being configured to direct the current to the induction transmitter includes being configured to direct the current from supercapacitor to the induction transmitter.

**Example Implementation 3:** The aerosol delivery device of any preceding or any subsequent example implementation, or any combination thereof, wherein the power source further includes terminals connectable with a source of energy from which the supercapacitor is chargeable.

**Example Implementation 4:** The aerosol delivery device of any preceding or any subsequent example implementation, or any combination thereof, wherein the power source further comprises the source of energy, and the source of energy is or includes a solid-state battery or lithium-ion battery.

**Example Implementation 5:** The aerosol delivery device of any preceding or any subsequent example implementation, or any combination thereof, wherein the control component further includes first and second switches are alternately switchable to effect the ZVS inverter topology.

**Example Implementation 6:** The aerosol delivery device of any preceding or any subsequent example implementation, or any combination thereof, wherein the control component and induction transmitter include respectively a capacitor and coil that form a tank circuit, and wherein the control component being configured to direct the current includes being configured to direct the current in cycles  
5 each of which includes a positive half in which the first and second switches are alternately switchable to charge the capacitor and direct current in a positive direction through the coil, and a negative half in which the first and second switches are alternately switchable to cause the capacitor to discharge and thereby direct current in a negative direction through the coil.

**Example Implementation 7:** The aerosol delivery device of any preceding or any subsequent  
10 example implementation, or any combination thereof, wherein the control component further includes high-side and low-side drivers for respectively the first and second switches.

**Example Implementation 8:** The aerosol delivery device of any preceding or any subsequent example implementation, or any combination thereof, wherein the aerosol delivery device further comprises a Hall effect current sensor positioned proximate the induction receiver and configured to produce a  
15 measurement of current through the induction receiver, the control component being configured to receive the measurement and control operation of at least one functional element of the aerosol delivery device in response thereto.

**Example Implementation 9:** The aerosol delivery device of any preceding or any subsequent example implementation, or any combination thereof, wherein wherein the induction transmitter is  
20 configured to at least partially surround the induction receiver when the control body is coupled with the cartridge.

**Example Implementation 10:** The aerosol delivery device of any preceding or any subsequent example implementation, or any combination thereof, wherein the induction transmitter defines a tubular or coiled configuration.

**Example Implementation 11:** A control body coupled or coupleable with a cartridge that is  
25 equipped with an induction receiver and contains an aerosol precursor composition, the control body being coupled or coupleable with the cartridge to form an aerosol delivery device in which the induction receiver is configured to generate heat when exposed to an oscillating magnetic field and thereby vaporize components of the aerosol precursor composition, the control body comprising: an induction transmitter  
30 configured to generate the oscillating magnetic field; and a control component configured to direct current to the induction transmitter to drive the induction transmitter to generate the oscillating magnetic field, the control component being configured to direct the current according to a zero voltage switching (ZVS) inverter topology.

**Example Implementation 12:** The control body of any preceding or any subsequent example  
35 implementation, or any combination thereof, wherein the control body further comprises a power source including a supercapacitor, and the control component being configured to direct the current to the induction transmitter includes being configured to direct current from supercapacitor to the induction transmitter.

**Example Implementation 13:** The control body of any preceding or any subsequent example implementation, or any combination thereof, wherein the power source further includes terminals connectable with a source of energy from which the supercapacitor is chargeable.

5 **Example Implementation 14:** The control body of any preceding or any subsequent example implementation, or any combination thereof, wherein the power source further comprises the source of energy, and the source of energy is or includes a solid-state battery or lithium-ion battery.

**Example Implementation 15:** The control body of any preceding or any subsequent example implementation, or any combination thereof, wherein the control component further includes first and second switches are alternately switchable to effect the ZVS inverter topology.

10 **Example Implementation 16:** The control body of any preceding or any subsequent example implementation, or any combination thereof, wherein the control component and induction transmitter include respectively a capacitor and coil that form a tank circuit, and wherein the control component being configured to direct the current includes being configured to direct the current in cycles each of which includes a positive half in which the first and second switches are alternately switchable to charge the  
15 capacitor and direct current in a positive direction through the coil, and a negative half in which the first and second switches are alternately switchable to cause the capacitor to discharge and thereby direct current in a negative direction through the coil.

**Example Implementation 17:** The control body of any preceding or any subsequent example implementation, or any combination thereof, wherein the control component further includes high-side and  
20 low-side drivers for respectively the first and second switches.

**Example Implementation 18:** The control body of any preceding or any subsequent example implementation, or any combination thereof, wherein the control component is further configured to receive a measurement of current through the induction receiver, the control component being configured to receive the measurement from a Hall effect current sensor positioned proximate the induction receiver, and control  
25 operation of at least one functional element of the aerosol delivery device in response to the measurement.

**Example Implementation 19:** The control body of any preceding or any subsequent example implementation, or any combination thereof, wherein the induction transmitter is configured to at least partially surround the induction receiver when the control body is coupled with the cartridge.

30 **Example Implementation 20:** The control body of any preceding or any subsequent example implementation, or any combination thereof, wherein the induction transmitter defines a tubular or coiled configuration.

These and other features, aspects, and advantages of the present disclosure will be apparent from a reading of the following detailed description together with the accompanying drawings, which are briefly described below. The present disclosure includes any combination of two, three, four or more features or  
35 elements set forth in this disclosure, regardless of whether such features or elements are expressly combined or otherwise recited in a specific example implementation described herein. This disclosure is intended to be read holistically such that any separable features or elements of the disclosure, in any of its aspects and

example implementations, should be viewed as combinable, unless the context of the disclosure clearly dictates otherwise.

It will therefore be appreciated that this Brief Summary is provided merely for purposes of summarizing some example implementations so as to provide a basic understanding of some aspects of the disclosure. Accordingly, it will be appreciated that the above described example implementations are merely examples and should not be construed to narrow the scope or spirit of the disclosure in any way. Other example implementations, aspects and advantages will become apparent from the following detailed description taken in conjunction with the accompanying drawings which illustrate, by way of example, the principles of some described example implementations.

10

#### BRIEF DESCRIPTION OF THE DRAWING(S)

Having thus described the disclosure in the foregoing general terms, reference will now be made to the accompanying drawings, which are not necessarily drawn to scale, and wherein:

FIG. 1 illustrates a perspective view of an aerosol delivery device comprising a cartridge and a control body, wherein the cartridge and the control body are coupled to one another according to an example implementation of the present disclosure;

FIG. 2 illustrates a perspective view of the aerosol delivery device of FIG. 1 wherein the cartridge and the control body are decoupled from one another according to an example implementation of the present disclosure;

FIG. 3 illustrates an exploded view of the control body of FIG. 1 wherein an induction transmitter thereof defines a tubular configuration according to an example implementation of the present disclosure;

FIG. 4 illustrates a sectional view through the control body of FIG. 3;

FIG. 5 illustrates a sectional view through the control body of FIG. 1 wherein an induction transmitter thereof defines a coiled configuration according to an example implementation of the present disclosure;

FIG. 6 illustrates an exploded view of the cartridge of FIG. 1 wherein a substrate thereof extends into an internal compartment defined by a container according to a first example implementation of the present disclosure;

FIG. 7 illustrates a sectional view through the cartridge of FIG. 6;

FIG. 8 illustrates a sectional view through the cartridge of FIG. 1 including a reservoir substrate in an internal compartment defined by a container according to a second example implementation of the present disclosure;

FIG. 9 illustrates a sectional view through the cartridge of FIG. 1 including a substrate in contact with an induction receiver according to a third example implementation of the present disclosure;

FIG. 10 illustrates a sectional view through the cartridge of FIG. 1 including an electronic control component according to a fourth example implementation of the present disclosure;

FIG. 11 illustrates a sectional view through the aerosol delivery device of FIG. 1 including the cartridge of FIG. 6 and the control body of FIG. 3 according to an example implementation of the present disclosure;

5 FIG. 12 illustrates various elements of a control body of the aerosol delivery device, according to various example implementations;

FIG. 13 schematically illustrates a method for assembling an aerosol delivery device according to an example implementation of the present disclosure; and

FIG. 14 schematically illustrates a method for aerosolization according to an example implementation of the present disclosure.

10

#### DETAILED DESCRIPTION

The present disclosure will now be described more fully hereinafter with reference to example implementations thereof. These example implementations are described so that this disclosure will be thorough and complete, and will fully convey the scope of the disclosure to those skilled in the art. Indeed, the disclosure may be embodied in many different forms and should not be construed as limited to the implementations set forth herein; rather, these implementations are provided so that this disclosure will satisfy applicable legal requirements. As used in the specification, and in the appended claims, the singular forms “a,” “an,” “the,” include plural variations unless the context clearly dictates otherwise.

15 The present disclosure provides descriptions of aerosol delivery devices. The aerosol delivery devices may use electrical energy to heat a material (preferably without combusting the material to any significant degree) to form an inhalable substance; such articles most preferably being sufficiently compact to be considered “hand-held” devices. An aerosol delivery device may provide some or all of the sensations (e.g., inhalation and exhalation rituals, types of tastes or flavors, organoleptic effects, physical feel, use rituals, visual cues such as those provided by visible aerosol, and the like) of smoking a cigarette, cigar, or pipe, without any substantial degree of combustion of any component of that article or device. The aerosol delivery device may not produce smoke in the sense of the aerosol resulting from by-products of combustion or pyrolysis of tobacco, but rather, that the article or device most preferably yields vapors (including vapors within aerosols that can be considered to be visible aerosols that might be considered to be described as smoke-like) resulting from volatilization or vaporization of certain components of the article or device, although in other implementations, the aerosol may not be visible. In highly preferred implementations, aerosol delivery devices may incorporate tobacco and/or components derived from tobacco. As such, the aerosol delivery device can be characterized as an electronic smoking article such as an electronic cigarette or “e-cigarette.” In another implementation, the aerosol delivery device may be characterized as a heat-not-burn cigarette. Further, it should be understood that the description of the mechanisms, components, features, apparatuses, devices, and methods disclosed herein are discussed in terms of implementations relating to aerosol delivery mechanisms by way of example only, and may be embodied and used in various other products and methods.

30  
35



Aerosol delivery devices of the present disclosure also can be characterized as being vapor-producing articles or medicament delivery articles. Thus, such articles or devices can be adapted so as to provide one or more substances (e.g., flavors and/or pharmaceutical active ingredients) in an inhalable form or state. For example, inhalable substances can be substantially in the form of a vapor (i.e., a substance that is in the gas phase at a temperature lower than its critical point). Alternatively, inhalable substances can be in the form of an aerosol (i.e., a suspension of fine solid particles or liquid droplets in a gas). For purposes of simplicity, the term “aerosol” as used herein is meant to include vapors, gases and aerosols of a form or type suitable for human inhalation, whether or not visible, and whether or not of a form that might be considered to be smoke-like.

In use, aerosol delivery devices of the present disclosure may be subjected to many of the physical actions employed by an individual in using a traditional type of smoking article (e.g., a cigarette, cigar or pipe that is employed by lighting and inhaling tobacco). For example, the user of an aerosol delivery device of the present disclosure can hold that article much like a traditional type of smoking article, draw on one end of that article for inhalation of aerosol produced by that article, take puffs at selected intervals of time, etc.

Aerosol delivery devices of the present disclosure generally include a number of components provided within an outer shell or body. The overall design of the outer shell or body can vary, and the format or configuration of the outer body that can define the overall size and shape of the smoking article can vary. Typically, an elongated body resembling the shape of a cigarette or cigar can be formed from a single, unitary shell; or the elongated body can be formed of two or more separable pieces. For example, an aerosol delivery device can comprise an elongated shell or body that can be substantially tubular in shape and, as such, resemble the shape of a conventional cigarette or cigar. In one implementation, all of the components of the aerosol delivery device are contained within one outer body or shell. Alternatively, an aerosol delivery device can comprise two or more shells that are joined and are separable. For example, an aerosol delivery device can possess at one end a control body comprising a shell containing one or more reusable components (e.g., an accumulator such as a rechargeable (e.g., Lithium Ion) battery, solid-state battery, thin-film solid-state battery and/or supercapacitor, and various electronics for controlling the operation of that article), and at the other end and removably attached thereto a shell containing a disposable portion (e.g., a disposable flavor-containing cartridge). More specific formats, configurations and arrangements of components within the single shell type of unit or within a multi-piece separable shell type of unit will be evident in light of the further disclosure provided herein. Additionally, various aerosol delivery device designs and component arrangements can be appreciated upon consideration of the commercially available aerosol delivery devices.

Aerosol delivery devices of the present disclosure most preferably comprise some combination of a power source (i.e., an electrical power source), at least one control component (e.g., means for actuating, controlling, regulating and/or ceasing power for heat generation, such as by controlling electrical current flow from the power source to other components of the aerosol delivery device), a heater or heat generation

component (e.g., an electrical resistance heating element or component commonly referred to as part of an “atomizer”), and an aerosol precursor composition (e.g., commonly a liquid capable of yielding an aerosol upon application of sufficient heat, such as ingredients commonly referred to as “smoke juice,” “e-liquid” and “e-juice,” and/or a solid or semi-solid tobacco material), and a mouthend region or tip for allowing draw upon the aerosol delivery device for aerosol inhalation (e.g., a defined air flow path through the article such that aerosol generated can be withdrawn therefrom upon draw).

Alignment of the components within the aerosol delivery device of the present disclosure can vary. In specific implementations, the aerosol precursor composition can be located near an end of the aerosol delivery device which may be configured to be positioned proximal to the mouth of a user so as to maximize aerosol delivery to the user. Other configurations, however, are not excluded. Generally, the heating element can be positioned sufficiently near the aerosol precursor composition so that heat from the heating element can volatilize the aerosol precursor (as well as one or more flavorants, medicaments, or the like that may likewise be provided for delivery to a user) and form an aerosol for delivery to the user. When the heating element heats the aerosol precursor composition, an aerosol is formed, released, or generated in a physical form suitable for inhalation by a consumer. It should be noted that the foregoing terms are meant to be interchangeable such that reference to release, releasing, releases, or released includes form or generate, forming or generating, forms or generates, and formed or generated. Specifically, an inhalable substance is released in the form of a vapor or aerosol or mixture thereof, wherein such terms are also interchangeably used herein except where otherwise specified.

As noted above, the aerosol delivery device may incorporate a battery or other power source (e.g., a supercapacitor) to provide current flow sufficient to provide various functionalities to the aerosol delivery device, such as powering of a heater, powering of control systems, powering of indicators, and the like. The power source can take on various implementations. Preferably, the power source is able to deliver sufficient power to rapidly heat the heating element to provide for aerosol formation and power the aerosol delivery device through use for a desired duration of time. The power source preferably is sized to fit conveniently within the aerosol delivery device so that the aerosol delivery device can be easily handled. Additionally, a preferred power source is of a sufficiently light weight to not detract from a desirable smoking experience.

More specific formats, configurations and arrangements of components within the aerosol delivery device of the present disclosure will be evident in light of the further disclosure provided hereinafter. Additionally, the selection of various aerosol delivery device components can be appreciated upon consideration of the commercially available electronic aerosol delivery devices. Further, the arrangement of the components within the aerosol delivery device can also be appreciated upon consideration of the commercially available electronic aerosol delivery devices.

As described hereinafter, the present disclosure relates to aerosol delivery devices. Aerosol delivery devices may be configured to heat an aerosol precursor composition to produce an aerosol. In some implementations, the aerosol delivery devices may comprise heat-not-burn devices, configured to heat a solid aerosol precursor composition (an extruded tobacco rod) or a semi-solid aerosol precursor composition

(e.g., a glycerin-loaded tobacco paste). In another implementation, the aerosol delivery devices may be configured to heat and produce an aerosol from a fluid aerosol precursor composition (e.g., a liquid aerosol precursor composition). Such aerosol delivery devices may include so-called electronic cigarettes.

Regardless of the type of aerosol precursor composition heated, aerosol delivery devices may  
5 include a heating element configured to heat the aerosol precursor composition. In some implementations, the heating element may comprise a resistive heating element. Resistive heating elements may be configured to produce heat when an electrical current is directed therethrough. Such heating elements often comprise a metal material and are configured to produce heat as a result of the electrical resistance associated with passing an electrical current therethrough. Such resistive heating elements may be  
10 positioned in proximity to the aerosol precursor composition. For example, in some implementations, the resistive heating elements may comprise one or more coils of a wire wound about a liquid transport element (e.g., a wick, which may comprise a porous ceramic, carbon, cellulose acetate, polyethylene terephthalate, fiberglass, or porous sintered glass) configured to draw an aerosol precursor composition therethrough. Alternatively, the heating element may be positioned in contact with a solid or semi-solid aerosol precursor  
15 composition. Such configurations may heat the aerosol precursor composition to produce an aerosol.

In some implementations aerosol delivery devices may include a control body and a cartridge. The control body may be reusable, whereas the cartridge may be configured for a limited number of uses and/or configured to be disposable. The cartridge may include the aerosol precursor composition. In order to heat the aerosol precursor composition, the heating element may also be positioned in the cartridge. The control  
20 body may include a power source, which may be rechargeable or replaceable, and thereby the control body may be reused with multiple cartridges.

Although the above-described aerosol delivery devices may be employed to heat an aerosol precursor composition to produce aerosol, such configurations may suffer from one or more disadvantages. In this regard, resistive heating elements may comprise a wire defining one or more coils that contact the  
25 aerosol precursor composition. For example, as noted above, the coils may wrap around a liquid transport element (e.g., a wick) to heat and aerosolize an aerosol precursor composition directed to the heating element through the liquid transport element. However, as a result of the coils defining a relatively small surface area, some of the aerosol precursor composition may be heated to an unnecessarily high extent during aerosolization, thereby wasting energy. Alternatively or additionally, some of the aerosol precursor  
30 composition that is not in contact with the coils of the heating element may be heated to an insufficient extent for aerosolization. Accordingly, insufficient aerosolization may occur, or aerosolization may occur with wasted energy.

Further, as noted above, resistive heating elements produce heat when electrical current is directed therethrough. Accordingly, as a result of positioning the heating element in contact with the aerosol  
35 precursor composition, charring of the aerosol precursor composition may occur. Such charring may occur as a result of the heat produced by the heating element and/or as a result of electricity traveling through the aerosol precursor composition at the heating element. Charring may result in build-up of material on the

heating element. Such material build-up may negatively affect the taste of the aerosol produced from the aerosol precursor composition.

As further described above, aerosol delivery devices may comprise a control body including a power source and a cartridge comprising a resistive heating element and an aerosol precursor composition. In order to direct electrical current to the resistive heating element, the control body and the cartridge may include electrical connectors configured to engage one another when the cartridge is engaged with the control body. However, usage of such electrical connectors may further complicate and increase the cost of such aerosol delivery devices. Additionally, in implementations of aerosol delivery devices including a fluid aerosol precursor composition, leakage thereof may occur at the terminals or other connectors within the cartridge.

Thus, implementations of the present disclosure are directed to aerosol delivery devices which may avoid some or all of the problems noted above. In this regard, FIG. 1 illustrates an aerosol delivery device **100** according to an example implementation of the present disclosure. The aerosol delivery device **100** may include a cartridge **102** and a control body **104**. The cartridge **102** and the control body **104** can be permanently or detachably aligned in a functioning relationship. In this regard, FIG. 1 illustrates the aerosol delivery device **100** in a coupled configuration, whereas FIG. 2 illustrates the aerosol delivery device in a decoupled configuration. Various mechanisms may connect the cartridge **102** to the control body **104** to result in a threaded engagement, a press-fit engagement, an interference fit, a magnetic engagement, or the like. The aerosol delivery device **100** may be substantially rod-like, substantially tubular shaped, or substantially cylindrically shaped in some implementations when the cartridge **102** and the control body **104** are in an assembled configuration.

In specific implementations, one or both of the cartridge **102** and the control body **104** may be referred to as being disposable or as being reusable. For example, the control body **104** may have a replaceable battery or a rechargeable battery, solid-state battery, thin-film solid-state battery, supercapacitor or the like, and thus may be combined with any type of recharging technology, including connection to a wall charger, connection to a car charger (i.e., cigarette lighter receptacle), and connection to a computer, such as through a universal serial bus (USB) cable or connector, connection to a photovoltaic cell (sometimes referred to as a solar cell) or solar panel of solar cells, or wireless radio frequency (RF) based charger. Further, in some implementations, the cartridge **102** may comprise a single-use cartridge, as disclosed in U.S. Pat. No. 8,910,639 to Chang et al., which is incorporated herein by reference in its entirety.

FIG. 3 illustrates an exploded view of the control body **104** of the aerosol delivery device **100** according to an example implementation of the present disclosure. As illustrated, the control body may comprise an induction transmitter **302**, an outer body **304**, a flow sensor **306** (e.g., a puff sensor or pressure switch), a control component **308** (e.g., a microprocessor, individually or as part of a microcontroller), a spacer **310**, a power source **312** (e.g., a battery, which may be rechargeable, and/or a supercapacitor), a circuit board with an indicator **314** (e.g., a light emitting diode (LED)), a connector circuit **316**, and an end cap **318**. Examples of power sources are described in U.S. Pat. App. Pub. No. 2010/0028766 by Peckerar et

al., and U.S. Pat. App. Ser. No. 14/918,926 to Sur et al., filed October 21, 2015, the disclosures of which are incorporated herein by reference in their respective entireties.

With respect to the flow sensor **306**, representative current regulating components and other current controlling components including various microcontrollers, sensors, and switches for aerosol delivery devices are described in U.S. Pat. No. 4,735,217 to Gerth et al., U.S. Pat. Nos. 4,922,901, 4,947,874, and 4,947,875, all to Brooks et al., U.S. Pat. No. 5,372,148 to McCafferty et al., U.S. Pat. No. 6,040,560 to Fleischhauer et al., U.S. Pat. No. 7,040,314 to Nguyen et al., and U.S. Pat. No. 8,205,622 to Pan, all of which are incorporated herein by reference in their entireties. Reference also is made to the control schemes described in U.S. App. Pub. No. 2014/0270727 to Ampolini et al., which is incorporated herein by reference in its entirety.

In one implementation, the indicator **314** may comprise one or more light emitting diodes. The indicator **314** can be in communication with the control component **308** through the connector circuit **316** and be illuminated, for example, during a user drawing on a cartridge (e.g., cartridge **102** of FIG. 2) coupled to the control body **104**, as detected by the flow sensor **306**. The end cap **318** may be adapted to make visible the illumination provided thereunder by the indicator **314**. Accordingly, the indicator **314** may be illuminated during use of the aerosol delivery device **100** to simulate the lit end of a smoking article. However, in other implementations, the indicator **314** can be provided in varying numbers and can take on different shapes and can even be an opening in the outer body (such as for release of sound when such indicators are present).

Still further components can be utilized in the aerosol delivery device of the present disclosure. For example, U.S. Pat. No. 5,154,192 to Sprinkel et al. discloses indicators for smoking articles; U.S. Pat. No. 5,261,424 to Sprinkel, Jr. discloses piezoelectric sensors that can be associated with the mouth-end of a device to detect user lip activity associated with taking a draw and then trigger heating of a heating device; U.S. Pat. No. 5,372,148 to McCafferty et al. discloses a puff sensor for controlling energy flow into a heating load array in response to pressure drop through a mouthpiece; U.S. Pat. No. 5,967,148 to Harris et al. discloses receptacles in a smoking device that include an identifier that detects a non-uniformity in infrared transmissivity of an inserted component and a controller that executes a detection routine as the component is inserted into the receptacle; U.S. Pat. No. 6,040,560 to Fleischhauer et al. describes a defined executable power cycle with multiple differential phases; U.S. Pat. No. 5,934,289 to Watkins et al. discloses photonic-optronic components; U.S. Pat. No. 5,954,979 to Counts et al. discloses means for altering draw resistance through a smoking device; U.S. Pat. No. 6,803,545 to Blake et al. discloses specific battery configurations for use in smoking devices; U.S. Pat. No. 7,293,565 to Griffen et al. discloses various charging systems for use with smoking devices; U.S. Pat. No. 8,402,976 to Fernando et al. discloses computer interfacing means for smoking devices to facilitate charging and allow computer control of the device; U.S. Pat. No. 8,689,804 to Fernando et al. discloses identification systems for smoking devices; and WO 2010/003480 by Flick discloses a fluid flow sensing system indicative of a puff in an aerosol generating system; all of the foregoing disclosures being incorporated herein by reference in their entireties. Further

examples of components related to electronic aerosol delivery articles and disclosing materials or components that may be used in the present article include U.S. Pat. No. 4,735,217 to Gerth et al.; U.S. Pat. No. 5,249,586 to Morgan et al.; U.S. Pat. No. 5,666,977 to Higgins et al.; U.S. Pat. No. 6,053,176 to Adams et al.; U.S. 6,164,287 to White; U.S. Pat No. 6,196,218 to Voges; U.S. Pat. No. 6,810,883 to Felter et al.;  
5 U.S. Pat. No. 6,854,461 to Nichols; U.S. Pat. No. 7,832,410 to Hon; U.S. Pat. No. 7,513,253 to Kobayashi; U.S. Pat. No. 7,896,006 to Hamano; U.S. Pat. No. 6,772,756 to Shayan; U.S. Pat. No. 8,156,944 and 8,375,957 to Hon; U.S. Pat. No. 8,794,231 to Thorens et al.; U.S. Pat. No. 8,851,083 to Oglesby et al.; U.S. Pat. No. 8,915,254 and 8,925,555 to Monsees et al.; U.S. Pat. App. Pub. Nos. 2006/0196518 and 2009/0188490 to Hon; U.S. Pat. App. Pub. No. 2010/0024834 to Oglesby et al.; U.S. Pat. App. Pub. No.  
10 2010/0307518 to Wang; U.S. Pat. App. Pub. No. 2014/0261408 to DePiano et al.; WO 2010/091593 to Hon; and WO 2013/089551 to Foo, each of which is incorporated herein by reference in its entirety. Further, U.S. Pat. Appl. Ser. No. 14/881,392 to Worm et al., filed October 13, 2015, discloses capsules that may be included in aerosol delivery devices and fob-shape configurations for aerosol delivery devices, and is incorporated herein by reference in its entirety. A variety of the materials disclosed by the foregoing  
15 documents may be incorporated into the present devices in various implementations, and all of the foregoing disclosures are incorporated herein by reference in their entireties.

Each of the components of the control body **104** may be at least partially received in the outer body **304**. The outer body **304** may extend from an engagement end **304'** to an outer end **304''**. The end cap **318** may be positioned at, and engaged with, the outer end **304''** of the outer body **304**. Thereby, the end cap  
20 **318**, which may be translucent or transparent, may be illuminated by the indicator **314** in order to simulate the lit end of a smoking article or perform other functions as described above. The opposing engagement end **304'** of the outer body **304** may be configured to engage the cartridge **102**.

FIG. 4 schematically illustrates a partial sectional view through the control body **104** proximate the engagement end **304'** of the outer body **304**. As illustrated, the induction transmitter **302** may extend  
25 proximate the engagement end **304'** of the outer body **304**. In one implementation, as illustrated in FIGS. 3 and 4, the induction transmitter **302** may define a tubular configuration. As illustrated in FIG. 4, the induction transmitter **302** may include a coil support **402** and a coil **404**. The coil support **402**, which may define a tubular configuration, may be configured to support the coil **404** such that the coil **404** does not move into contact with, and thereby short-circuit with, the induction receiver or other structures. The coil  
30 support **402** may comprise a nonconductive material, which may be substantially transparent to the oscillating magnetic field produced by the coil **404**. The coil **404** may be imbedded in, or otherwise coupled to, the coil support **402**. In the illustrated implementation, the coil **404** is engaged with an inner surface of the coil support **402** so as to reduce any losses associated with transmitting the oscillating magnetic field to the induction receiver. However, in other implementations, the coil may be positioned at an outer surface of  
35 the coil support or fully imbedded in the coil support. Further, in some implementations, the coil may comprise an electrical trace printed on or otherwise coupled to the coil support, or a wire. In either implementation, the coil may define a helical configuration.

In an alternate implementation, as illustrated in FIG. 5, the induction transmitter **302** may include the coil **404** without the coil support **402**. In each implementation, the induction transmitter **302** may define an inner chamber **406** about which the induction transmitter extends.

As further illustrated in FIGS. 3-5, in some implementations, the induction transmitter **302** may be coupled to a support member **320**. The support member **320** may be configured to engage the induction transmitter **302** and support the induction transmitter **302** within the outer body **304**. For example, the induction transmitter **302** may be imbedded in, or otherwise coupled to the support member **320**, such that the induction transmitter is fixedly positioned within the outer body **304**. By way of further example, the induction transmitter **302** may be injection molded into the support member **320**.

The support member **320** may engage an internal surface of the outer body **304** to provide for alignment of the support member with respect to the outer body. Thereby, as a result of the fixed coupling between the support member **320** and the induction transmitter **302**, a longitudinal axis of the induction transmitter may extend substantially parallel to a longitudinal axis of the outer body **304**. Thus, the induction transmitter **302** may be positioned out of contact with the outer body **304**, so as to avoid transmitting current from the induction transmitter to the outer body. However, in some implementations, as shown in FIG. 5, an optional insulator **502** may be positioned between the induction transmitter **302** and the outer body **304**, so as to prevent contact therebetween. As may be understood, the insulator **502** and the support member **320** may comprise any nonconductive material such as an insulating polymer (e.g., plastic or cellulose), glass, rubber, and porcelain. Alternatively, the induction transmitter **302** may contact the outer body **304** in implementations in which the outer body is formed from a nonconductive material such as a plastic, glass, rubber, or porcelain.

As described below in detail, the induction transmitter **302** may be configured to receive an electrical current from the power source **312** and wirelessly heat the cartridge **102** (see, e.g., FIG. 2). Thus, as illustrated in FIGS. 4 and 5, the induction transmitter **302** may include electrical connectors **408** configured to supply the electrical current thereto. For example, the electrical connectors **408** may connect the induction transmitter **302** to the control component **312**. Thereby, current from the power source **312** may be selectively directed to the induction transmitter **302** as controlled by the control component **312**. For example, the control component **312** may direct current from the power source **312** (see, e.g., FIG. 3) to the induction transmitter **302** when a draw on the aerosol delivery device **100** is detected by the flow sensor **306**. The electrical connectors **408** may comprise, by way of example, terminals, wires, or any other implementation of connector configured to transmit electrical current therethrough. Further, the electrical connectors **408** may include a negative electrical connector and a positive electrical connector.

In some implementations, the power source **312** may comprise a battery and/or a supercapacitor, which may supply direct current. As described elsewhere herein, operation of the aerosol delivery device may require directing alternating current to the induction transmitter **302** to produce an oscillating magnetic field in order to induce eddy currents in the induction receiver. Accordingly, in some implementations, the control component **308** of the control body **104** may include an inverter or an inverter circuit configured to

transform direct current provided by the power source 312 to alternating current that is provided to the induction transmitter 302.

FIG. 6 illustrates an exploded view of a cartridge 600 that in some examples may correspond to the cartridge 102 of FIG. 1. As illustrated, the cartridge 600 may include an induction receiver 602, an outer body 604, a container 606, a sealing member 608, and a substrate 610. The outer body 604 may extend between an engagement end 604' and an outer end 604". Some or all of the remaining components of the cartridge 600 may be positioned at least partially within the outer body 604.

The cartridge 600 may additionally include a mouthpiece 612. The mouthpiece 612 may be integral with the outer body 604 or the container 606 or a separate component. The mouthpiece 612 may be positioned at the outer end 604" of the outer body 604.

FIG. 7 illustrates a sectional view through the cartridge 600 in an assembled configuration. As illustrated, the container 606 may be received within the outer body 604. Further the sealing member 608 may be engaged with the container 606 to define an internal compartment 614. As further illustrated in FIG. 7, in some implementations, the sealing member 608 may additionally engage the outer body 604.

In some implementations, the sealing member 608 may comprise an elastic material such as a rubber or silicone material. In these implementations, the sealing material 608 may compress to form a tight seal with the container 606 and/or the outer body 604. An adhesive may be employed to further improve the seal between the sealing member 608 and the container 606 and/or the outer body 604. In another implementation, the sealing member 608 may comprise an inelastic material such as a plastic material or a metal material. In these implementations, the sealing member 608 may be adhered or welded (e.g., via ultrasonic welding) to the container 606 and/or the outer body 604. Accordingly, via one or more of these mechanisms, the sealing member 608 may substantially seal the internal compartment 614 shut.

The induction receiver 602 may be engaged with the sealing member 608. In one implementation, the induction receiver 602 may be partially imbedded in the sealing member 608. For example, the induction receiver 602 may be injection molded into the sealing member 608 such that a tight seal and connection is formed therebetween. Accordingly, the sealing member 608 may retain the induction receiver at a desired position. For example, the induction receiver 602 may be positioned such that a longitudinal axis of the induction receiver extends substantially coaxially with a longitudinal axis of the outer body 604.

Further, the substrate 610 may engage the sealing member 608. In one implementation, the substrate 610 may extend through the sealing member 608. In this regard, the sealing member 608 may define an aperture 616 extending therethrough, and through which the substrate 610 is received. Thereby, the substrate 610 may extend into the internal compartment 614. For example, as illustrated in FIG. 7, an end of the substrate 610 may be received in a pocket 618 defined by the container 606. Accordingly, the container 606 and the sealing member 608 may each engage the substrate 610 and cooperatively maintain the substrate at a desired position. For example, a longitudinal axis of the substrate 610 may be positioned substantially coaxial with a longitudinal axis of the induction receiver 602. Thereby, as illustrated, in some implementations, the substrate 610 may be positioned in proximity to, but out of contact with, the induction



receiver **602**. By avoiding direct contact between the substrate **610** and the induction receiver **602**, the induction coil may remain substantially free of residue buildup from use, and hence the cartridge may optionally be refilled with aerosol precursor composition and/or a new substrate or otherwise reused. However, as discussed below, direct contact between the substrate and the induction receiver may be preferable in some implementations.

The substrate **610** may include an aerosol precursor composition. The aerosol precursor composition may comprise one or more of a solid tobacco material, a semi-solid tobacco material, and a liquid aerosol precursor composition. For example, solid tobacco materials and semi-solid tobacco materials may be employed in implementations of the aerosol delivery device **100** defining so-called heat-not-burn cigarettes. Conversely, by way of further example, fluid (e.g., liquid) aerosol precursor compositions may be employed in implementations of the aerosol delivery device **100** defining so-called electronic cigarettes.

Representative types of liquid aerosol precursor components and formulations are set forth and characterized in U.S. Pat. No. 7,726,320 to Robinson et al. and U.S. Pat. Pub. Nos. 2013/0008457 to Zheng et al.; 2013/0213417 to Chong et al. 2015/0020823 to Lipowicz et al.; and 2015/0020830 to Koller, as well as WO 2014/182736 to Bowen et al. and U.S. Pat. No. 8,881,737 to Collett et al., the disclosures of which are incorporated herein by reference. Other aerosol precursors that may be employed include the aerosol precursors that have been incorporated in the VUSE® product by R. J. Reynolds Vapor Company, the BLU product by Imperial Tobacco Group PLC, the MISTIC MENTHOL product by Mistic Ecigs, and the VYPE product by CN Creative Ltd. Also desirable are the so-called “smoke juices” for electronic cigarettes that have been available from Johnson Creek Enterprises LLC. Implementations of effervescent materials can be used with the aerosol precursor, and are described, by way of example, in U.S. Pat. App. Pub. No. 2012/0055494 to Hunt et al., which is incorporated herein by reference. Further, the use of effervescent materials is described, for example, in U.S. Pat. No. 4,639,368 to Niazi et al.; U.S. Pat. No. 5,178,878 to Wehling et al.; U.S. Pat. No. 5,223,264 to Wehling et al.; U.S. Pat. No. 6,974,590 to Pather et al.; U.S. Pat. No. 7,381,667 to Bergquist et al.; U.S. Pat. No. 8,424,541 to Crawford et al; and U.S. Pat. No. 8,627,828 to Strickland et al., as well as US Pat. Pub. Nos. 2010/0018539 to Brinkley et al.; and 2010/0170522 to Sun et al.; and PCT WO 97/06786 to Johnson et al., all of which are incorporated by reference herein.

Representative types of solid and semi-solid aerosol precursor compositions and formulations are disclosed in U.S. Pat. No. 8,424,538 to Thomas et al.; U.S. Pat. No. 8,464,726 to Sebastian et al.; U.S. Pat. Appl. Pub. No. 2015/0083150 to Conner et al.; U.S. Pat. Appl. Pub. No. 2015/0157052 to Ademe et al.; and U.S. Pat. Appl. Ser. No. 14/755,205, filed June 30, 2015, to Nordskog et al.

In implementations of the cartridge **102** wherein the aerosol precursor composition comprises a liquid or other fluid, the substrate **610** may be configured to retain the aerosol precursor composition therein and release a vapor therefrom when heat is applied thereto by the induction receiver **602** in the manner described below. In some implementations, the substrate **610** may retain a sufficient quantity of the aerosol precursor composition to last a desired extent. In other implementations it may be preferable to provide the cartridge **102** with an increased capacity of the aerosol precursor composition. Examples of materials that

may be employed in the substrate **610** in implementations wherein the substrate is configured to hold a fluid aerosol precursor composition include a porous ceramic, carbon, cellulose acetate, polyethylene terephthalate, fiberglass, and porous sintered glass.

In this regard, as illustrated by way of example in FIGS. 6 and 7, in one implementation, the  
5 container **606** may comprise a reservoir and the internal compartment **614** may be configured to receive the liquid aerosol precursor composition. In this implementation, the substrate **610** may comprise a liquid transport element (e.g., a wick) configured to receive the aerosol precursor composition from the internal compartment **614** and transport the aerosol precursor composition therealong. Accordingly, the aerosol precursor composition may be transported from the internal compartment **614** to locations along the  
10 longitudinal length of the substrate **610** about which the induction receiver **602** extends.

As may be understood, the implementation of the cartridge **600** illustrated in FIG. 7 is provided for example purposes only. In this regard, various alternative implementations of cartridges **102** are provided herein by way of further example. Note that although the implementations of the cartridge **102** are described separately herein, each of the respective components and features thereof may be combined in any manner  
15 except as may be otherwise noted herein.

FIG. 8 illustrates another cartridge **800** that in some examples may correspond to the cartridge **102** of FIG. 1. The cartridge **800** is similar to cartridge **700**, but in which the sealing member **708** is positioned proximate the outer end **604'** of the outer body **604**, as opposed to at the engagement end **604'**. In this implementation, the container **806** may include the aperture **816** extending therethrough and the sealing  
20 member **808** may define the pocket **818**, in order to support the substrate **610** in substantially the same manner as described above. Accordingly, the sealing member **608** may be positioned at the engagement end **604'** of the container **606**, (see FIG. 7), or the sealing member **808** may be positioned at the outer end **604'** of the container **806** (see FIG. 8).

In some implementations, the container may be sufficiently sealed such that leakage of the aerosol  
25 precursor composition is substantially avoided. However, as illustrated in FIG. 8, in some implementations, the cartridge **800** may further comprise a reservoir substrate **820**. As may be understood, the reservoir substrate **820** may be employed in any of the cartridges disclosed herein including an internal compartment **614**.

In one implementation, the reservoir substrate **820** may comprise a plurality of layers of nonwoven  
30 fibers formed into substantially the shape of a tube fully or partially encircling the substrate **610** within the internal compartment **820**. In other implementations, the reservoir substrate **820** may comprise a porous ceramic, carbon, cellulose acetate, polyethylene terephthalate, fiberglass, or porous sintered glass. Thereby, a liquid aerosol precursor composition can be sorptively retained by the reservoir substrate **820**. As a result of contact between the reservoir substrate **820** and the reservoir, the reservoir substrate is in fluid  
35 communication with the substrate **610**. Thus, the substrate **610** may be configured to transport the liquid aerosol precursor composition from the reservoir substrate **820** in the internal compartment **614** via capillary

action or other liquid transport mechanisms to locations along the longitudinal length of the substrate **610** outside of the internal compartment.

As noted above, in some implementations of the cartridge **600, 800**, the substrate **610** may be positioned in proximity to, but out of contact with, the induction receiver **602**. Such a configuration may avoid build-up of residue on the induction receiver due to the lack of direct contact therebetween. However, in other implementations, the substrate **610** may contact the induction receiver. In this regard, FIG. 9 illustrates yet another cartridge **900** that in some examples may correspond to the cartridge **102** of FIG. 1, similar to cartridges **600, 800** but in which the substrate **910** may contact the induction receiver **602**. Usage of this configuration may allow for a relatively larger substrate **910**, which may contain a relatively greater quantity of the aerosol precursor composition, without necessarily increasing the size of the induction receiver **602**. Further, direct contact between the induction receiver and the substrate may facilitate heat transfer from the induction receiver to the substrate via convection, which may be significantly more efficient than the radiant heating employed in implementations in which there is no direct contact therebetween. Accordingly, it should be understood that each of the implementations of the cartridges disclosed herein may include direct contact between the induction receiver and the substrate and/or the aerosol precursor composition. Providing for direct contact between the substrate **910** and the induction receiver **602** may be employed, by way of example, in implementations in which aerosol precursor composition comprises a solid tobacco material or a semi-solid tobacco material, which may be less prone to causing residue build-up on the induction receiver than a liquid aerosol precursor composition.

In the implementations of the cartridges **600, 800** illustrated in FIGS. 6-8, the substrate **610** extends into the internal compartment **614**. However, in other implementations, the cartridge may not define an internal compartment. For example, the cartridge **900** illustrated in FIG. 9 does not include an internal compartment. In this regard, the substrate **910** may comprise a sufficient quantity of the aerosol precursor composition, such that usage of an internal compartment may not be need in some implementations. Thus, for example, the induction receiver **602** and the substrate **910** may be substantially coextensive, such that the longitudinal ends thereof terminate at substantially the same points. In this regard, the substrate induction receiver **602** and/or the substrate **910** may be received in a pocket **922** defined by the outer body **904** or otherwise engaged (e.g., directly engaged) with the outer body. Thus, in some implementations, the cartridge **900** may define a relatively simple configuration that may not include a container, a sealing member, or an internal compartment. Such a configuration may reduce the complexity and/or cost of the cartridge **900**.

As described above, in some implementations, the substrate **910** may not extend into an internal compartment and may instead terminate, for example, proximate the outer body **904**. As further described above with respect to FIG. 9, in one implementation, the cartridge **900** may not include a container or an internal compartment. However, in another implementation, the cartridge may include the container defining the internal compartment without the substrate extending into the compartment. This is shown in FIG. 10, which illustrates yet another cartridge **1000** that may correspond to the cartridge **104** of FIG. 1. As

shown, the cartridge **1000** may include the container **1006** defining the internal compartment **614** without the substrate **1010** extending into the compartment. In this regard, the induction receiver **602** and the substrate **1010** may be engaged with the container or the outer body. For example, in FIG. 10, the induction receiver **602** and the substrate **1010** are each engaged with the container **1006**. By way of further example, as described above, the induction receiver **602** may be partially embedded in the container **1006**. Further, the substrate **1010** may engage a pocket **1022** defined by the container **1006**.

By configuring the cartridge **1000** such that the substrate **1010** does not extend into the internal compartment **614**, the compartment may be employed for purposes other than a reservoir for the aerosol precursor composition. For example, as illustrated in FIG. 10, in some implementations, the cartridge **1000** may include an electronic control component **1024**. As described below, the electronic control component **1024** may be employed in authentication of the cartridge **1000** or employed for other purposes.

As noted above, each of the cartridges **102** of the present disclosure is configured to operate in conjunction with the control body **104** to produce an aerosol. By way of example, FIG. 11 illustrates the cartridge **600** engaged with the control body **104**. As illustrated, when the control body **104** is engaged with the cartridge **600**, the induction transmitter **302** may at least partially surround, preferably substantially surround, and more preferably fully surround the induction receiver **602** (e.g., by extending around the circumference thereof). Further, the induction transmitter **302** may extend along at least a portion of the longitudinal length of the induction receiver **602**, and preferably extend along a majority of the longitudinal length of the induction receiver, and most preferably extend along substantially all of the longitudinal length of the induction receiver.

Accordingly, the induction receiver **602** may be positioned inside of the inner chamber **406** about which the induction transmitter **302** extends. Accordingly, when a user draws on the mouthpiece **612** of the cartridge **600**, the pressure sensor **306** may detect the draw. Thereby, the control component **308** may direct current from the power source **312** (see, e.g., FIG. 3) to the induction transmitter **302**. The induction transmitter **302** may thereby produce an oscillating magnetic field. As a result of the induction receiver **602** being received in the inner chamber **406**, the induction receiver may be exposed to the oscillating magnetic field produced by the induction transmitter **302**.

In particular, the induction transmitter **302** and the induction receiver **602** may form an electrical transformer. A change in current in the induction transmitter **302**, as directed thereto from the power source **312** (see, e.g., FIG. 3) by the control component **308**, may produce an alternating electromagnetic field that penetrates the induction receiver **602**, thereby generating electrical eddy currents within the induction receiver. The alternating electromagnetic field may be produced by directing alternating current to the induction transmitter **302**. As noted above, in some implementations, the control component **308** may include an inverter or inverter circuit configured to transform direct current provided by the power source **312** to alternating current that is provided to the induction transmitter **302**.

The eddy currents flowing the material defining the induction receiver **602** may heat the induction receiver through the Joule effect, wherein the amount of heat produced is proportional to the square of the

electrical current times the electrical resistance of the material of the induction receiver. In implementations of the induction receiver **602** comprising magnetic materials, heat may also be generated by magnetic hysteresis losses. Several factors contribute to the temperature rise of the induction receiver **602** including, but not limited to, proximity to the induction transmitter **302**, distribution of the magnetic field, electrical resistivity of the material of the induction receiver, saturation flux density, skin effects or depth, hysteresis losses, magnetic susceptibility, magnetic permeability, and dipole moment of the material.

In this regard, both the induction receiver **602** and the induction transmitter **302** may comprise an electrically conductive material. By way of example, the induction transmitter **302** and/or the induction receiver **602** may comprise various conductive materials including metals such as copper and aluminum, alloys of conductive materials (e.g., diamagnetic, paramagnetic, or ferromagnetic materials) or other materials such as a ceramic or glass with one or more conductive materials imbedded therein. In another implementation, the induction receiver may comprise conductive particles or objects of any of various sizes received in a reservoir filled with the aerosol precursor composition. In some implementations, the induction receiver may be coated with or otherwise include a thermally conductive passivation layer (e.g., a thin layer of glass), to prevent direct contact with the aerosol precursor composition.

Accordingly, the induction receiver **602** may be heated. The heat produced by the induction receiver **602** may heat the substrate **610** including the aerosol precursor composition, such that an aerosol **1102** is produced. Accordingly, the induction receiver **602** may comprise an atomizer. By positioning the induction receiver **602** around the substrate **610** at a substantially uniform distance therefrom (e.g., by aligning the longitudinal axes of the substrate and the induction receiver), the substrate and the aerosol precursor composition may be substantially uniformly heated.

The aerosol **1102** may travel around or through the induction receiver **602** and the induction transmitter **302**. For example, as illustrated, in one implementation, the induction receiver **602** may comprise a mesh, a screen, a helix, a braid, or other porous structure defining a plurality of apertures extending therethrough. In other implementations, the induction receiver may comprise a rod imbedded in a substrate or otherwise in contact with an aerosol precursor composition, a plurality of beads or particles imbedded in a substrate or otherwise in contact with an aerosol precursor composition, or a sintered structure. In each of these implementations, the aerosol **1102** may freely pass through the induction receiver **602** and/or the substrate to allow the aerosol to travel through the mouthpiece to the user.

The aerosol **1102** may mix with air **1104** entering through inlets **410** (see, e.g., FIG. 4), which may be defined in the control body **104** (e.g., in the outer body **304**). Accordingly, an intermixed air and aerosol **1106** may be directed to the user. For example, the intermixed air and aerosol **1106** may be directed to the user through one or more through holes **626** defined in the outer body **604** of the cartridge **600**. In some implementations, the sealing member **608** may additionally include through holes **628** extending therethrough, which may align with the through holes **626** defined through the outer body **604**. However, as may be understood, the flow pattern through the aerosol delivery device **100** may vary from the particular

configuration described above in any of various manners without departing from the scope of the present disclosure.

As further noted above, in some implementations, the cartridge **102** may further comprise a second electronic control component. For example, the cartridge **1000** illustrated in FIG. 10 includes second control component **1024**. The second control component **1024** may be configured to allow for authentication of the cartridge **1000**. In this regard, in some implementations, the second control component **1024** may be configured to output a code to the control body **104** which the (first) control component **308** (see, e.g., FIG. 3) can analyze. Thereby, for example, the control component **308** may direct current to the induction transmitter **302** only when the cartridge **1000** is verified as authentic. In some implementations, the second control component may include terminals that connect to the control body. More preferably, the second control component **1024** may comprise a radio-frequency identification (RFID) chip configured to wirelessly transmit a code or other information to the control body **104**. Thereby, the aerosol delivery device **100** may be used without requiring engagement of electrical connectors between the cartridge and the control body. Further, various examples of control components and functions performed thereby are described in U.S. Pat. App. Pub. No. 2014/0096782 to Sears et al., which is incorporated herein by reference in its entirety.

As indicated above, in some implementations, the control component **308** of the control body **104** may include an inverter or an inverter circuit configured to transform direct current provided by the power source **312** to alternating current that is provided to the induction transmitter **302**. FIG. 12 illustrates the induction transmitter **302**, control component **308** and power source **312**, according to various example implementations. In according to example implementations in which the induction receiver **602** of the cartridge **102** may be configured to generate heat when exposed to an oscillating magnetic field and thereby vaporize components of the aerosol precursor composition. The induction transmitter **302** may be configured to generate the oscillating magnetic field, and the control component **308** may be configured to direct current to the induction transmitter **302** to drive the induction transmitter **302** to generate the oscillating magnetic field.

As explained above, in some examples, the power source **312** may include a supercapacitor such as an electric double-layer capacitor, hybrid capacitor or the like. In these examples, the control component **308** may be configured to direct the current to the induction transmitter **302** from supercapacitor to the induction transmitter **302**.

In some examples, the power source **312** may further include terminals connectable with a source of energy from which the supercapacitor is chargeable. As indicated above, for example, the control body **104** may be combined with any type of recharging technology (e.g., wall charger, car charger, computer, photovoltaic cell, solar panel of solar cells, wireless RF based charger). In some examples, the power source **312** may further include the source of energy, and this source of energy may be or include a solid-state battery or lithium-ion battery.

In accordance with example implementations of the present disclosure, the control component **308** may be configured to direct the current to the induction transmitter **302** according to a zero voltage switching (ZVS) inverter topology, which may reduce an amount of heat produced in the aerosol delivery device **100**. As shown, for example, the control component **308** may include a microprocessor **1202** configured to control first and second switches **Q1**, **Q2**, which may be alternately switchable to effect the ZVS inverter topology.

The control component **308** and induction transmitter **302** may also include respectively a capacitor **C** (or parallel capacitors) and coil **404** (shown as inductor **L1**) that form a tank circuit **1204**. In these examples, the control component **308** may direct the current in cycles each of which includes a positive half and a negative half. In the positive half, the first and second switches **Q1**, **Q2** may be alternately switchable to charge the capacitor **C** and direct current in a positive direction through the coil **404**. In the negative half, then, the first and second switches **Q1**, **Q2** may be alternately switchable to cause the capacitor **C** to discharge and thereby direct current in a negative direction through the coil **404**.

In the arrangement shown in FIG. 12, the first and second switches **Q1**, **Q2** may be switched respectively on and off in the positive half of a cycle, and respectively off and on in the negative half of the cycle. In the positive half of the cycle, when **Q1** is switched on and **Q2** switched off, current may be directed from the power source **312** to energize the tank circuit **1204**. As shown, this current may be directed from the power source **312** to the tank circuit **1204** through a voltage regulator **1206** such as a low-dropout (LDO) regulator, and/or an electronic choke (shown as inductor **L2**). In the negative half of the cycle, when **Q1** is switched off and **Q2** switched on, energy stored in the capacitor **C** may flow in the negative direction through the coil **404** (inductor **L1**). In the cycle including the positive and negative halves, the control component **308** may generate alternating current from a direct current voltage from the power source **312**. And as the energy stored in the capacitor **C** is used to energize the coil **404** in the negative half, the topology is ZVS.

During the cycles in which current is directed through the tank circuit **1204**, the tank circuit **1204** may have a characteristic resonating frequency as follows:

$$f = \frac{1}{2\pi\sqrt{L1C}}$$

At the resonating frequency, the change in current through the coil **404** may produce an alternating electromagnetic field that penetrates the induction receiver **602** and induces electrical eddy currents within the induction receiver **602**. These eddy currents may heat the induction receiver **602** through the Joule effect. The heat produced by the induction receiver **602** may heat the substrate **610** including the aerosol precursor composition, such that an aerosol **1102** is produced.

One example of a suitable switch that may be used to implement the first and second switches **Q1**, **Q2** is a metal-oxide-semiconductor field-effect transistor (MOSFET). These and similar switches have finite switch on and off times. To facilitate the switches being alternately on and off to effect the ZVS inverter topology, the control component **308** may further include high-side and low-side drivers **1208**, **1210**

for respectively the first and second switches **Q1**, **Q2**. In some examples, these drivers may be or include diodes.

In some examples, the aerosol delivery device **100** may further protect against the temperature of the induction receiver **602** reaching or exceeding a threshold temperature. In some of these examples, the control component **308**, or more particularly its microprocessor **1202**, may be further configured to receive a measurement of current through the induction receiver **602**. This measurement may be received from a Hall effect current sensor positioned proximate the induction receiver **602**. This Hall effect current sensor may be part of the cartridge **102**, or in some examples, the control body **104**. The control component **308** may then control operation of at least one functional element of the aerosol delivery device **100** in response to the measurement, such as to reduce the temperature of the induction receiver **602** in instances in which the measurement indicates a temperature at or above a threshold temperature. One manner of reducing temperature may be to include further air outlets in the aerosol delivery device **100**, may be control to vent air out of the aerosol delivery device **100**. Some examples of a suitable aerosol delivery device equipped with a Hall effect current sensor are described in U.S. Pat. Appl. Ser. No. 14/993,762 to Sur, filed January 12, 2016, which is incorporated herein by reference in its entirety.

As described above, the present disclosure relates to aerosol delivery device including a control body comprising a wireless power transmitter configured to receive an electrical current from a power source and wirelessly heat an atomizer. As may be understood, various wireless heating techniques may be employed to heat an aerosol precursor composition, which may be contained in a reservoir and/or in contact with a substrate. In some implementations, the atomizer may be wirelessly heated without transmitting electrical current to the atomizer.

In the implementations described above, the wireless power transmitter may comprise an induction transmitter and the atomizer may comprise an induction receiver. Thereby, eddy currents may be induced at the induction receiver in order to produce heat. As further noted above, the induction transmitter may be configured to at least partially surround the induction receiver. By way of further example, in other implementations, the atomizer may be wirelessly heated using radiant heating, sonic heating, photonic heating (e.g., via a laser), and/or microwave heating.

However, various other techniques and mechanisms may be employed in other implementations to wirelessly heat an atomizer. For example, electrical current may be wirelessly transmitted to an atomizer, and such wireless power transmission techniques may be employed with any implementation of atomizer such as wire coil resistive heating elements. Example implementations of wireless power transmission methods and mechanisms are provided in U.S. Pat. Appl. Ser. No. 14/814,866 to Sebastian et al., filed July 31, 2015, which is incorporated herein by reference in its entirety.

Note that although the present disclosure generally describes heating a substrate comprising an aerosol precursor composition positioned in proximity to the induction receiver to produce an aerosol, in other implementations, the induction receiver may be configured to heat an aerosol precursor composition directed (e.g., dispensed) thereto. For example, U.S. Pat. Appl. Ser. Nos. 14/309,282, filed June 19, 2014;



14/524,778, filed October 27, 2014; and 14/289,101, filed May 28, 2014, each to Brammer et al., disclose fluid aerosol precursor composition delivery mechanisms and methods, which are incorporated herein by reference in their entireties. Such fluid aerosol precursor composition delivery mechanisms and methods may be employed to direct an aerosol precursor composition from a reservoir to the induction receiver to  
5 produce an aerosol. In an additional implementation, the induction receiver may comprise a hollow needle connected to a reservoir, wherein capillary action directs the aerosol precursor composition into the needle to replenish the needle as the aerosol precursor composition is vaporized by the needle. Note further that while example shapes and configurations of the induction receiver and the induction transmitter are described herein, various other configurations and shapes may be employed.

10 FIG. 13 illustrates various operations in a method **1300** for assembling an aerosol delivery device, according to some example implementations. As illustrated in FIG. 13, the method may include providing a substrate comprising an aerosol precursor composition at operation **1302**. The method may further include providing an induction receiver at operation **1304**. Additionally, the method may include positioning the substrate in proximity to the induction receiver at operation **1306**. The induction receiver may be configured  
15 to be exposed to an oscillating magnetic field to heat the aerosol precursor composition to produce an aerosol.

In some implementations positioning the substrate in proximity to the induction receiver at operation **1306** may comprise positioning the substrate in direct contact with the induction receiver. Further, positioning the substrate in proximity to the induction receiver at operation **1306** may include positioning the  
20 substrate inside the induction receiver. The method may additionally include filling the substrate with the aerosol precursor composition. The aerosol precursor composition may comprise a liquid aerosol precursor composition.

The method may additionally include providing an induction transmitter and positioning the induction transmitter such that the induction transmitter at least partially surrounds the induction receiver.  
25 Positioning the induction transmitter may include positioning the induction transmitter out of direct contact with the induction receiver.

The method may additionally include forming a cartridge comprising the substrate and the induction receiver. Further, the method may include forming a control body comprising the induction transmitter. Positioning the induction transmitter such that the induction transmitter at least partially surrounds the  
30 induction receiver may include coupling the cartridge to the control body. Additionally, forming the control body may include coupling a power source to the induction transmitter.

FIG. 14 illustrates various operation in a method **1400** for aerosolization, according to some example implementations. As illustrated in FIG. 14, the method may include providing a cartridge at operation **1402**. The cartridge may include an aerosol precursor composition and an atomizer. The method  
35 may additionally include providing a control body at operation **1404**. The control body may include a power source and a wireless power transmitter. The method may further include directing current from the power source to the wireless power transmitter at operation **1406**. Additionally, the method may include wirelessly

heating the atomizer with the wireless power transmitter to heat the aerosol precursor composition to produce an aerosol at operation **1408**.

5 Many modifications and other implementations of the disclosure will come to mind to one skilled in the art to which this disclosure pertains having the benefit of the teachings presented in the foregoing descriptions and the associated drawings. Therefore, it is to be understood that the disclosure is not to be limited to the specific implementations disclosed herein and that modifications and other implementations are intended to be included within the scope of the appended claims. Although specific terms are employed herein, they are used in a generic and descriptive sense only and not for purposes of limitation.

## WHAT IS CLAIMED IS:

1. An aerosol delivery device comprising:  
a substrate configured to carry an aerosol precursor composition;  
an induction transmitter configured to generate an oscillating magnetic field;  
5 an induction receiver positioned in proximity to the substrate, and configured to generate heat when exposed to the oscillating magnetic field and thereby vaporize components of the aerosol precursor composition; and  
a control component configured to direct current to the induction transmitter to drive the induction transmitter to generate the oscillating magnetic field, the control component being configured to direct the current according to a zero voltage switching (ZVS) inverter topology.  
10
2. The aerosol delivery device of Claim 1 further comprising a power source including a supercapacitor,  
wherein the control component being configured to direct the current to the induction transmitter  
15 includes being configured to direct the current from supercapacitor to the induction transmitter.
3. The aerosol delivery device of Claim 2, wherein the power source further includes terminals connectable with a source of energy from which the supercapacitor is chargeable.
- 20 4. The aerosol delivery device of Claim 3, wherein the power source further comprises the source of energy, and the source of energy is or includes a solid-state battery or lithium-ion battery.
5. The aerosol delivery device of Claim 1, wherein the control component further includes first and second switches are alternately switchable to effect the ZVS inverter topology.  
25
6. The aerosol delivery device of Claim 5, wherein the control component and induction transmitter include respectively a capacitor and coil that form a tank circuit, and  
wherein the control component being configured to direct the current includes being configured to direct the current in cycles each of which includes a positive half in which the first and second switches are  
30 alternately switchable to charge the capacitor and direct current in a positive direction through the coil, and a negative half in which the first and second switches are alternately switchable to cause the capacitor to discharge and thereby direct current in a negative direction through the coil.
7. The aerosol delivery device of Claim 5, wherein the control component further includes  
35 high-side and low-side drivers for respectively the first and second switches.

8. The aerosol delivery device of Claim 1 further comprising a Hall effect current sensor positioned proximate the induction receiver and configured to produce a measurement of current through the induction receiver, the control component being configured to receive the measurement and control operation of at least one functional element of the aerosol delivery device in response thereto.

5

9. The aerosol delivery device of Claim 1, wherein the induction transmitter is configured to at least partially surround the induction receiver when the control body is coupled with the cartridge.

10

10. The aerosol delivery device of Claim 9, wherein the induction transmitter defines a tubular or coiled configuration.

15

11. A control body coupled or coupleable with a cartridge that is equipped with an induction receiver and contains an aerosol precursor composition, the control body being coupled or coupleable with the cartridge to form an aerosol delivery device in which the induction receiver is configured to generate heat when exposed to an oscillating magnetic field and thereby vaporize components of the aerosol precursor composition, the control body comprising:

an induction transmitter configured to generate the oscillating magnetic field; and

a control component configured to direct current to the induction transmitter to drive the induction transmitter to generate the oscillating magnetic field, the control component being configured to direct the current according to a zero voltage switching (ZVS) inverter topology.

20

12. The control body of Claim 11 further comprising a power source including a supercapacitor, wherein the control component being configured to direct the current to the induction transmitter includes being configured to direct the current from supercapacitor to the induction transmitter.

25

13. The control body of Claim 12, wherein the power source further includes terminals connectable with a source of energy from which the supercapacitor is chargeable.

30

14. The control body of Claim 13, wherein the power source further comprises the source of energy, and the source of energy is or includes a solid-state battery or lithium-ion battery.

15. The control body of Claim 11, wherein the control component further includes first and second switches are alternately switchable to effect the ZVS inverter topology.

35

16. The control body of Claim 15, wherein the control component and induction transmitter include respectively a capacitor and coil that form a tank circuit, and

wherein the control component being configured to direct the current includes being configured to direct the current in cycles each of which includes a positive half in which the first and second switches are alternately switchable to charge the capacitor and direct current in a positive direction through the coil, and a negative half in which the first and second switches are alternately switchable to cause the capacitor to discharge and thereby direct current in a negative direction through the coil.

17. The control body of Claim 15, wherein the control component further includes high-side and low-side drivers for respectively the first and second switches.

18. The control body of Claim 11, wherein the control component is further configured to receive a measurement of current through the induction receiver, the control component being configured to receive the measurement from a Hall effect current sensor positioned proximate the induction receiver, and control operation of at least one functional element of the aerosol delivery device in response to the measurement.

19. The control body of Claim 11, wherein the induction transmitter is configured to at least partially surround the induction receiver when the control body is coupled with the cartridge.

20. The control body of Claim 19, wherein the induction transmitter defines a tubular or coiled configuration.

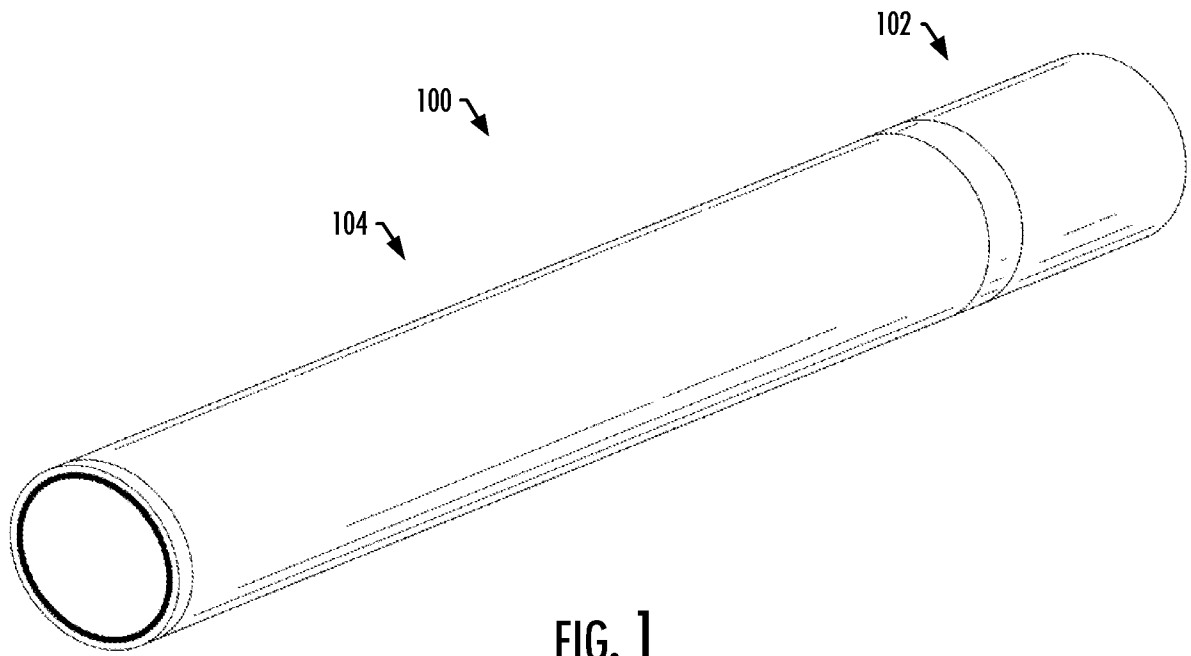

FIG. 1

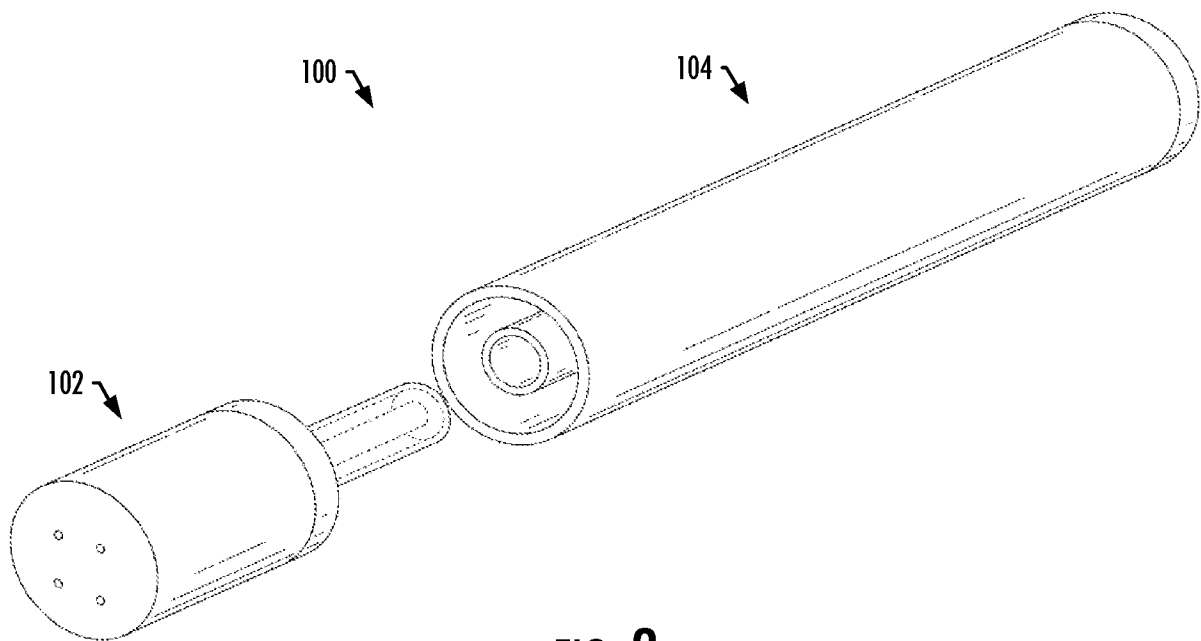

FIG. 2

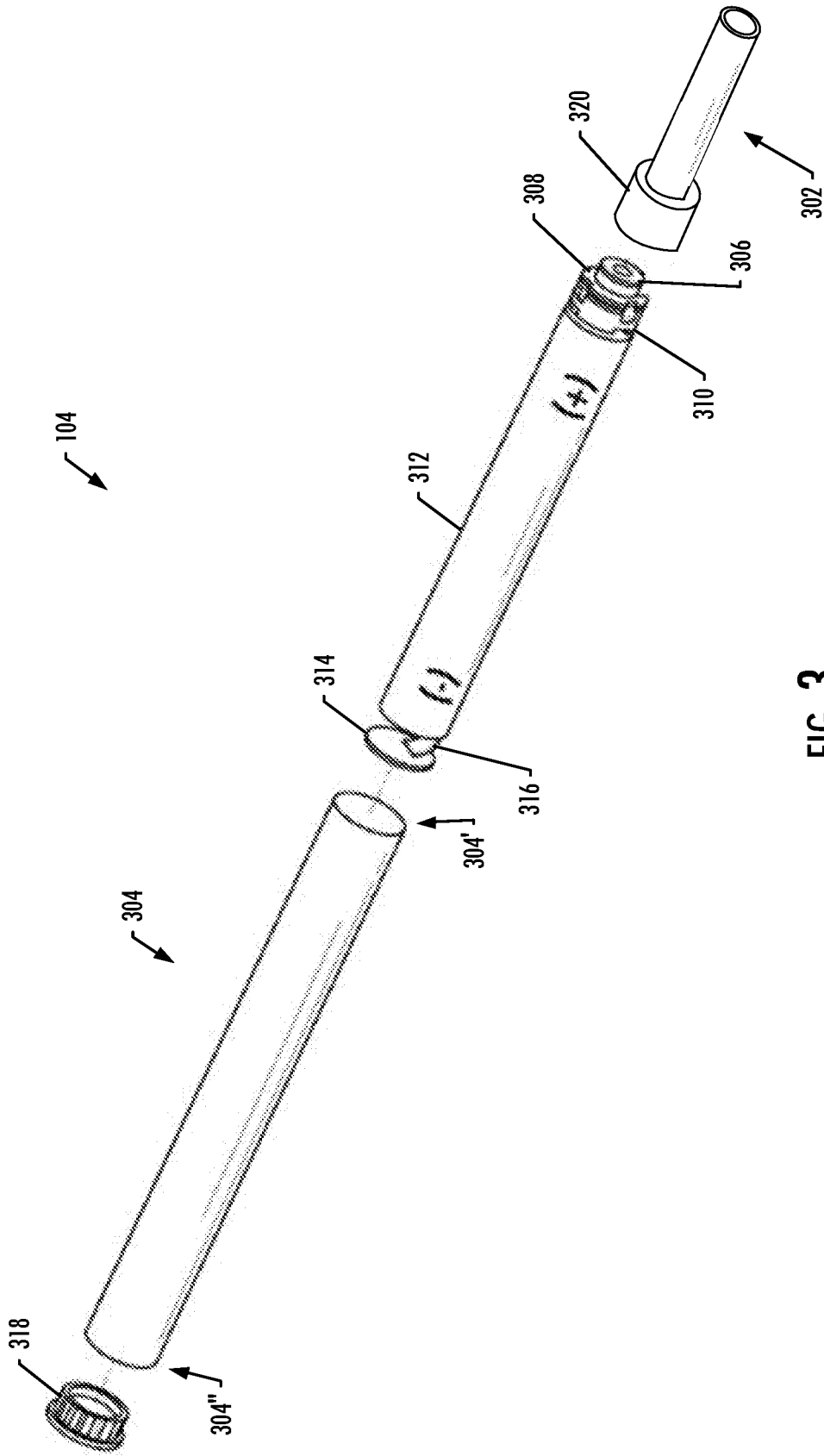

FIG. 3

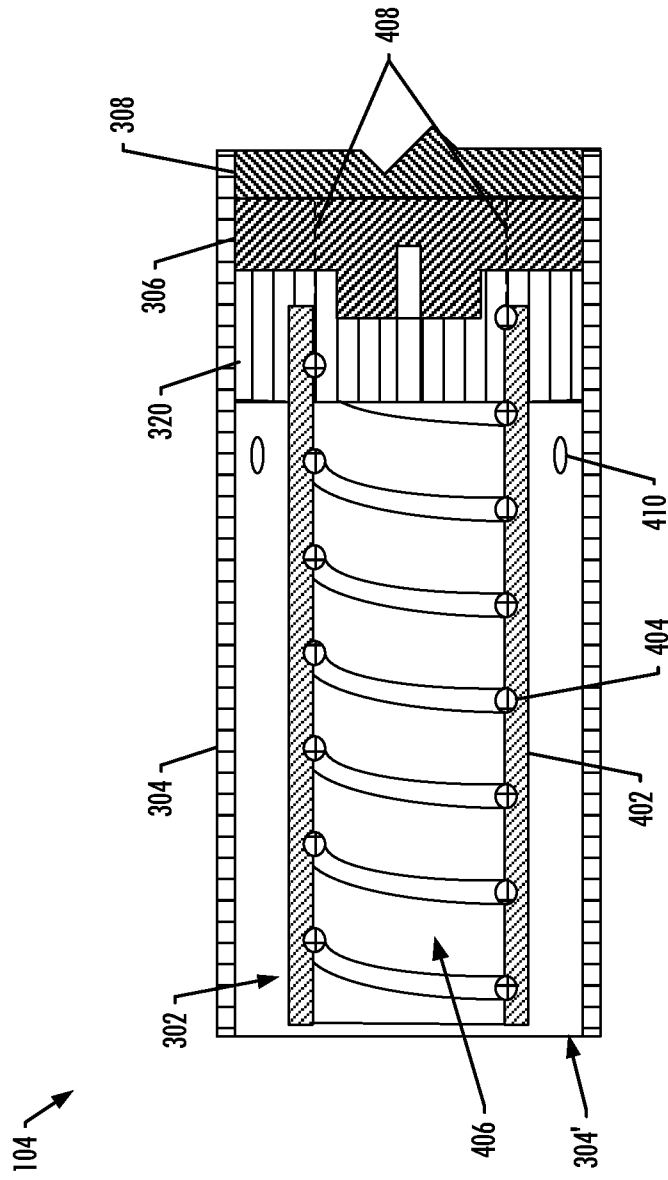

FIG. 4



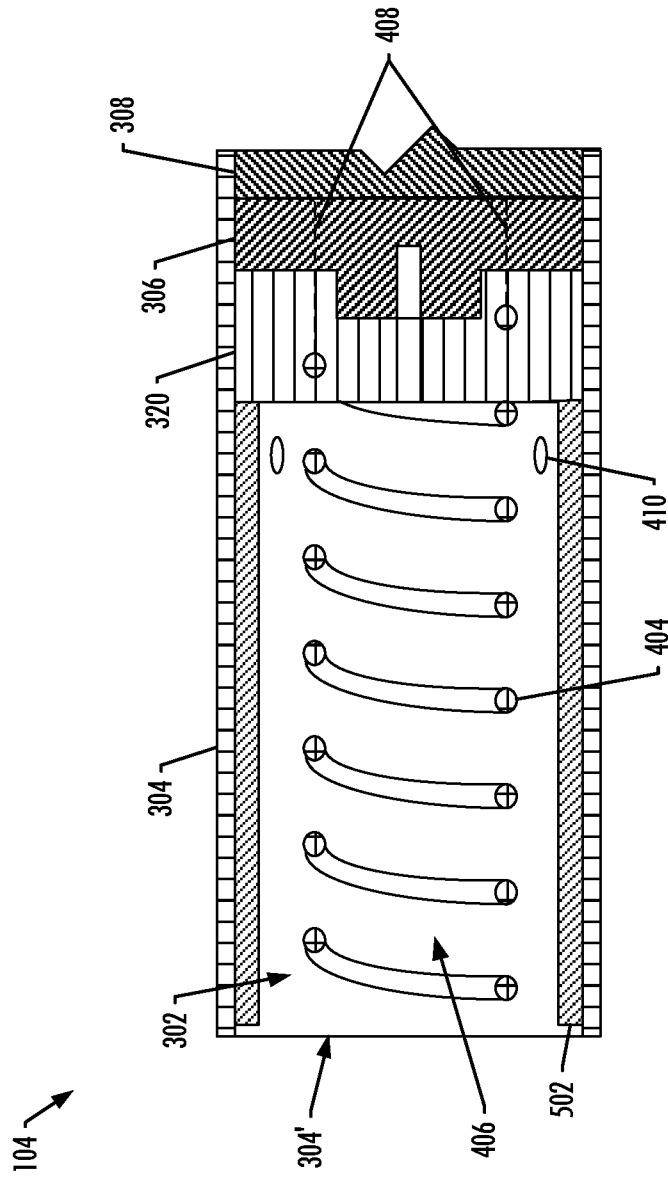

FIG. 5

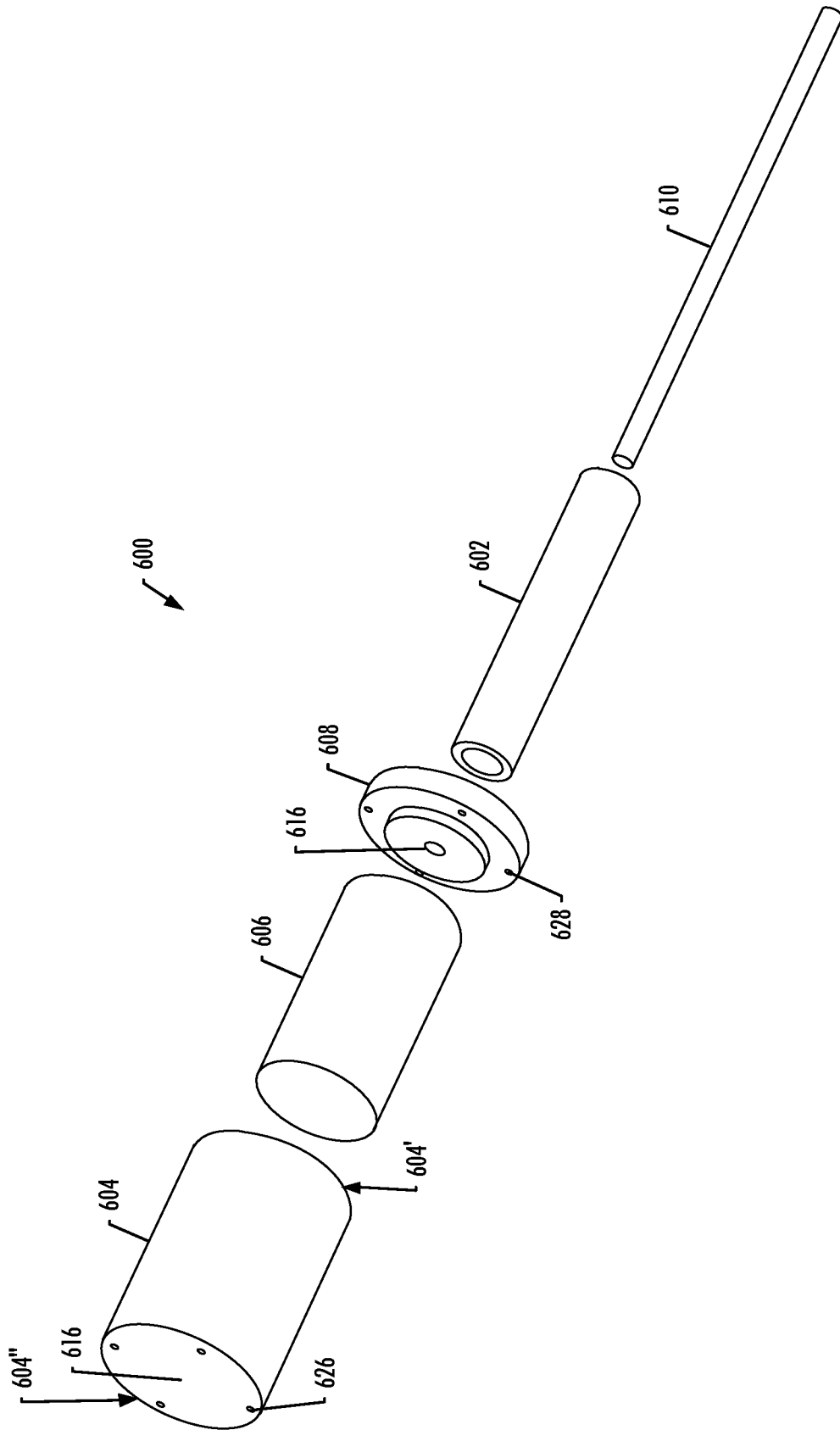

FIG. 6

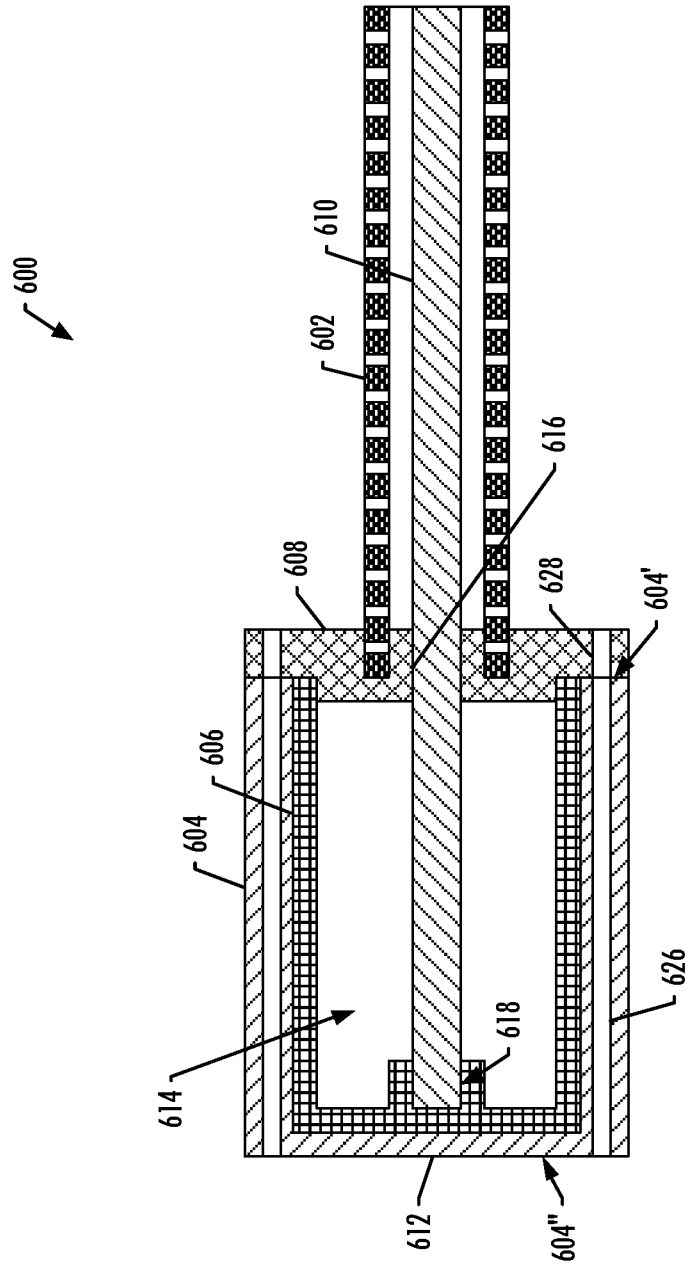

FIG. 7

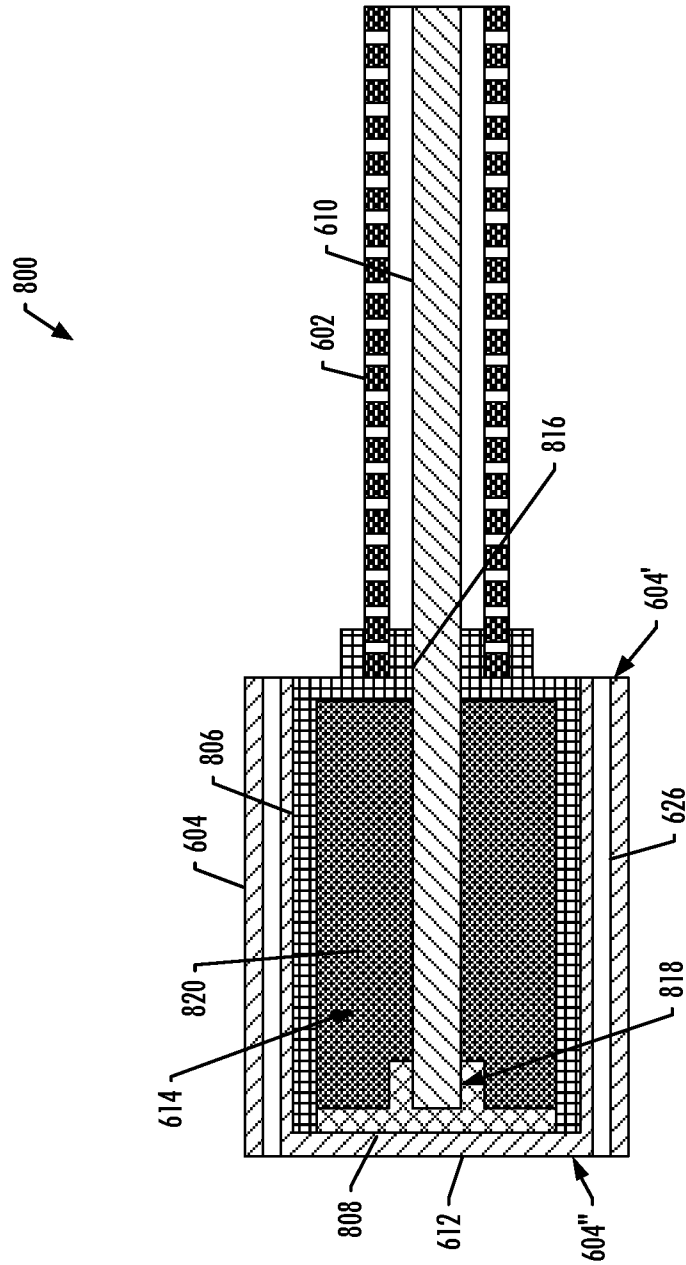

FIG. 8

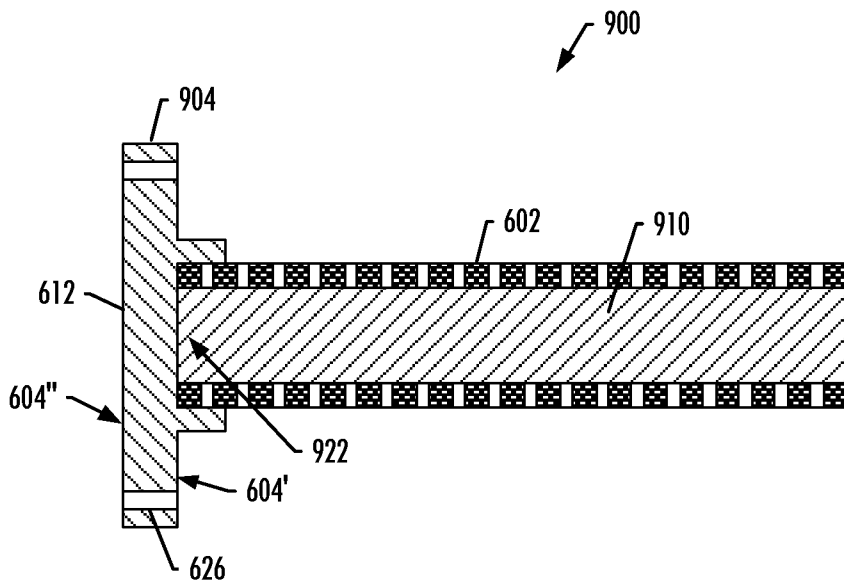

FIG. 9

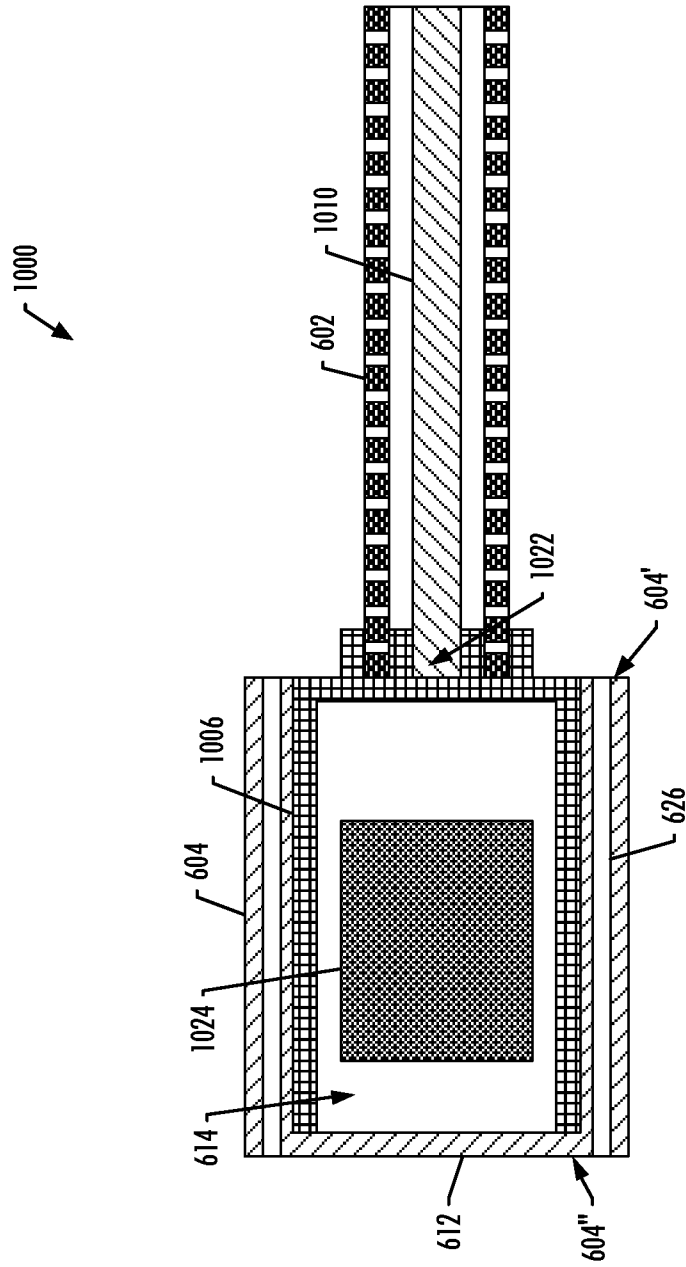

FIG. 10

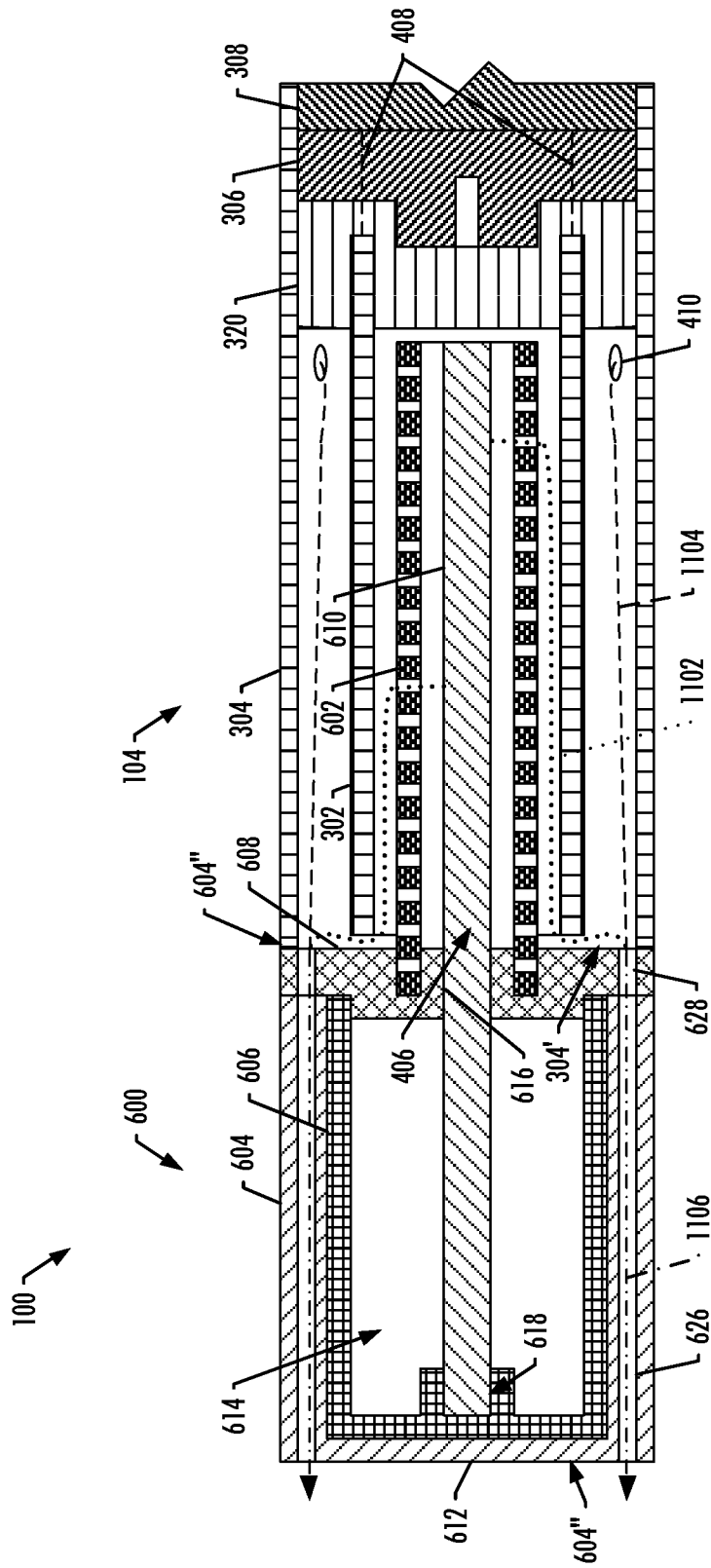

FIG. 11

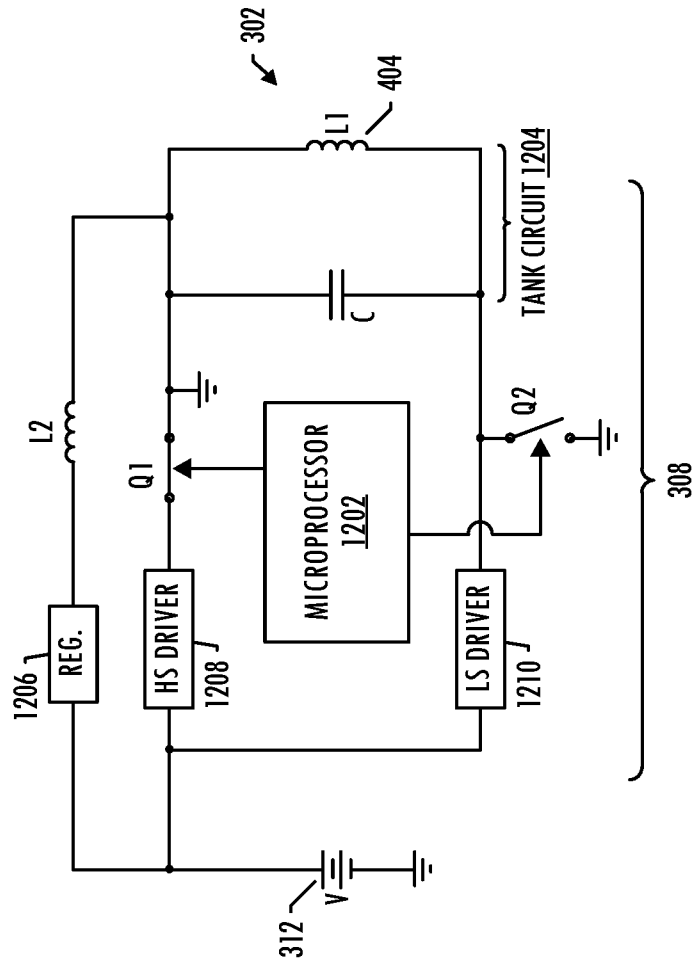

FIG. 12



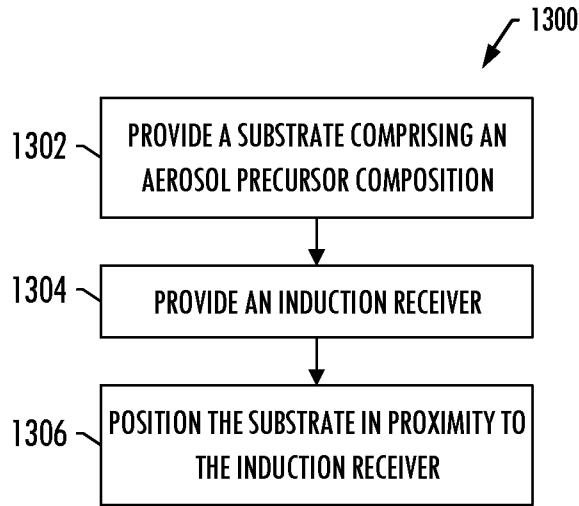

FIG. 13

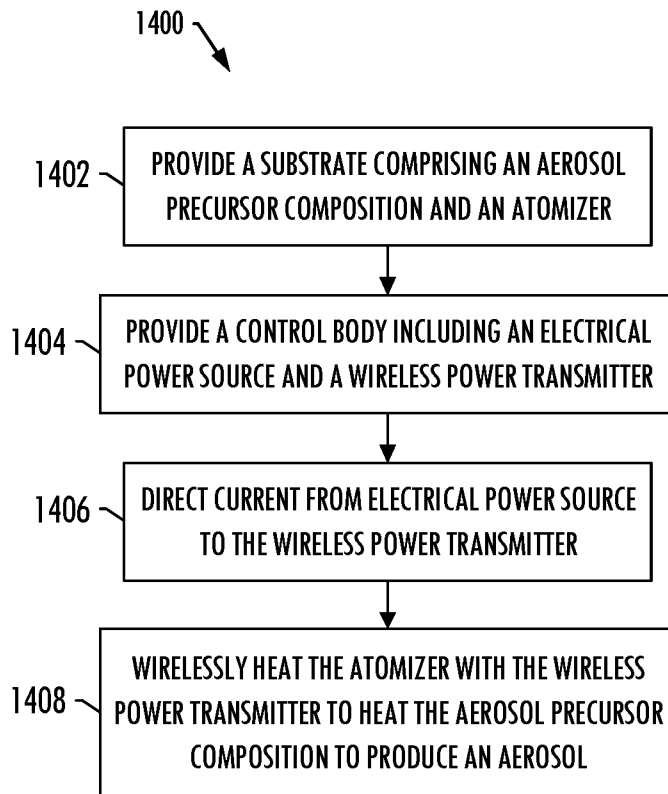

FIG. 14

# INTERNATIONAL SEARCH REPORT

International application No <b>PCT/IB2017/050293</b>
--

<b>A. CLASSIFICATION OF SUBJECT MATTER</b> INV. A24F47/00 ADD.		
According to International Patent Classification (IPC) or to both national classification and IPC		
<b>B. FIELDS SEARCHED</b>		
Minimum documentation searched (classification system followed by classification symbols) A24F		
Documentation searched other than minimum documentation to the extent that such documents are included in the fields searched		
Electronic data base consulted during the international search (name of data base and, where practicable, search terms used) EPO-Internal, WPI Data		
<b>C. DOCUMENTS CONSIDERED TO BE RELEVANT</b>		
Category*	Citation of document, with indication, where appropriate, of the relevant passages	Relevant to claim No.
X	CA 2 946 480 A1 (PHILIP MORRIS PRODUCTS SA [CH]) 26 November 2015 (2015-11-26)	1,5-7, 9-11, 15-17, 19,20
Y	the whole document  & Nathan O. Sokal ET AL: "Class-E High-Efficiency RF/Microwave Power Amplifiers: Principles of Operation, Design Procedures, and Experimental Verification" In: "Analog Circuit Design", 1 January 2003 (2003-01-01), Springer US, Boston, MA, XP055370125, ISBN: 978-0-306-47950-2 pages 269-301, DOI: 10.1007/0-306-47950-8_14, Items 2 and 12 ----- -/--	2-4,8, 12-14,18
<input checked="" type="checkbox"/> Further documents are listed in the continuation of Box C.		
<input checked="" type="checkbox"/> See patent family annex.		
* Special categories of cited documents :		
"A" document defining the general state of the art which is not considered to be of particular relevance "E" earlier application or patent but published on or after the international filing date "L" document which may throw doubts on priority claim(s) or which is cited to establish the publication date of another citation or other special reason (as specified) "O" document referring to an oral disclosure, use, exhibition or other means "P" document published prior to the international filing date but later than the priority date claimed	"T" later document published after the international filing date or priority date and not in conflict with the application but cited to understand the principle or theory underlying the invention "X" document of particular relevance; the claimed invention cannot be considered novel or cannot be considered to involve an inventive step when the document is taken alone "Y" document of particular relevance; the claimed invention cannot be considered to involve an inventive step when the document is combined with one or more other such documents, such combination being obvious to a person skilled in the art "&" document member of the same patent family	
Date of the actual completion of the international search	Date of mailing of the international search report	
11 May 2017	24/05/2017	
Name and mailing address of the ISA/ European Patent Office, P.B. 5818 Patentlaan 2 NL - 2280 HV Rijswijk Tel. (+31-70) 340-2040, Fax: (+31-70) 340-3016	Authorized officer  <b>Schwertfeger, C</b>	

**INTERNATIONAL SEARCH REPORT**

International application No PCT/IB2017/050293
---

C(Continuation). DOCUMENTS CONSIDERED TO BE RELEVANT

Category*	Citation of document, with indication, where appropriate, of the relevant passages	Relevant to claim No.
Y	WO 2014/150247 A1 (REYNOLDS TOBACCO CO R [US]) 25 September 2014 (2014-09-25) page 10, line 26 - line 33 -----	2-4, 12-14
Y	WO 2014/138244 A1 (REYNOLDS TOBACCO CO R [US]) 12 September 2014 (2014-09-12) page 25, line 24 - line 27 -----	8,18
A	GB 2 067 415 A (BARD INC C R) 30 July 1981 (1981-07-30) page 3, line 80 - line 97 -----	1-20

# INTERNATIONAL SEARCH REPORT

Information on patent family members

International application No PCT/IB2017/050293
---

Patent document cited in search report	Publication date	Patent family member(s)	Publication date	
CA 2946480	A1	26-11-2015	AU 2015263328 A1	01-09-2016
			CA 2946480 A1	26-11-2015
			CN 106455713 A	22-02-2017
			EP 3145345 A1	29-03-2017
			KR 20170008209 A	23-01-2017
			SG 11201608763R A	29-11-2016
			TW 201603724 A	01-02-2016
			US 2017079330 A1	23-03-2017
			WO 2015177045 A1	26-11-2015
			-----	
WO 2014150247	A1	25-09-2014	CN 105208884 A	30-12-2015
			EP 2967140 A1	20-01-2016
			HK 1220094 A1	28-04-2017
			JP 2016517270 A	16-06-2016
			KR 20150130458 A	23-11-2015
			RU 2015139369 A	24-04-2017
			US 2014270727 A1	18-09-2014
			WO 2014150247 A1	25-09-2014
-----				
WO 2014138244	A1	12-09-2014	CN 105163610 A	16-12-2015
			EP 2964037 A1	13-01-2016
			HK 1220088 A1	28-04-2017
			JP 2016513453 A	16-05-2016
			US 2014253144 A1	11-09-2014
			WO 2014138244 A1	12-09-2014
-----				
GB 2067415	A	30-07-1981	BR 8008414 A	14-07-1981
			CA 1152400 A	23-08-1983
			DE 3045351 A1	03-09-1981
			FR 2472393 A1	03-07-1981
			GB 2067415 A	30-07-1981
			IT 1193571 B	08-07-1988
			JP S5829107 B2	20-06-1983
			JP S56100069 A	11-08-1981
			SE 443096 B	17-02-1986
			US 4291838 A	29-09-1981
			-----	