

(19) World Intellectual Property
Organization
International Bureau



(43) International Publication Date
27 May 2004 (27.05.2004)

PCT

(10) International Publication Number
WO 2004/044419 A1

- (51) International Patent Classification⁷: **F03D 11/00**, H02G 13/00
- (21) International Application Number: PCT/DK2003/000778
- (22) International Filing Date: 12 November 2003 (12.11.2003)
- (25) Filing Language: Danish
- (26) Publication Language: English
- (30) Priority Data: PA 2002 01745 12 November 2002 (12.11.2002) DK
- (71) Applicant (for all designated States except US): **LM GLASFIBER A/S** [DK/DK]; Rolles Moellevej 1, DK-6640 Lunderskov (DK).
- (72) Inventors; and
- (75) Inventors/Applicants (for US only): **MØLLER**
- (74) Agent: **CHAS. HUDE A/S**; H.C. Andersens Boulevard 33, DK-1780 Copenhagen V (DK).
- (81) Designated States (national): AE, AG, AL, AM, AT (utility model), AU, AZ, BA, BB, BG, BR, BW, BY, BZ, CA, CH, CN, CO, CR, CU, CZ (utility model), DE (utility model), DE, DK (utility model), DK, DM, DZ, EC, EE (utility model), EE, ES, FI (utility model), FI, GB, GD, GE, HR, HU, ID, IL, IN, IS, JP, KE, KG, KP, KR (utility model), KZ, LC, LK, LR, LS, LT, LU, LV, MA, MD, MG, MK, MN, MW, MX, MZ, NI, NO, NZ, OM, PG, PH, PL, PT, RO, RU, SC, SD, SE, SG, SK (utility model), SK, SL, SY, TJ, TM, TN, TR, TT, TZ, UA, UG, US, UZ, VC, VN, YU, ZA, ZM, ZW.
- (84) Designated States (regional): ARIPO patent (BW, GH, GM, KE, LS, MW, MZ, SD, SL, SZ, TZ, UG, ZM, ZW),

[Continued on next page]

(54) Title: LIGHTNING PROTECTION OF A PITCH-CONTROLLED WIND TURBINE BLADE

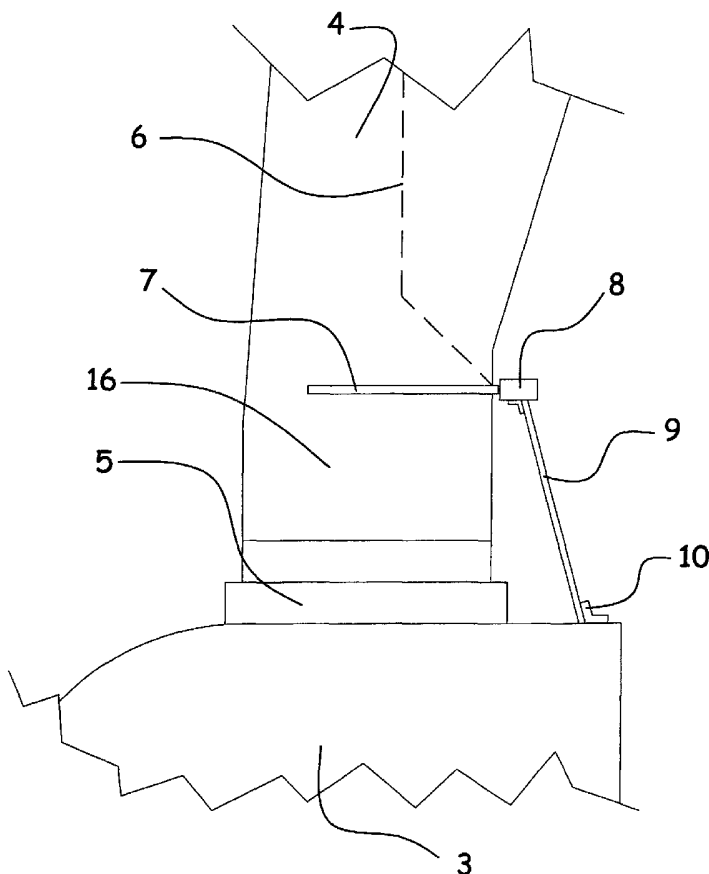

(57) Abstract: A wind turbine rotor including a rotor hub (3) and a plurality of blades (4), and where each blade root (16) is connected to said rotor hub through a pitch bearing (5) in such a manner that the pitch angle of the blade is adjustable by a turning of the blade about its longitudinal axis relative to the rotor hub. The blade is provided with at least one electrically conducting lightning down-conductor (6) extending in the longitudinal direction of the blade to the blade root and being electrically isolated from the pitch bearing (5). A spark gap (15) is provided between the lightning down-conductor and the rotor hub, said spark gap (15) being adapted to conduct a lightning current passing through the lightning down-conductor. A sliding contact connection (7, 12) is provided parallel to the spark gap (15) between the lightning down-conductor (6) and the rotor hub (3), said sliding contact connection ensuring electrical contact between said lightning down-conductor (6) and said rotor hub (3) irrespective of the pitch angle of the blade. The invention also relates to a wind turbine including such a rotor.

WO 2004/044419 A1



Eurasian patent (AM, AZ, BY, KG, KZ, MD, RU, TJ, TM),
European patent (AT, BE, BG, CH, CY, CZ, DE, DK, EE,
ES, FI, FR, GB, GR, HU, IE, IT, LU, MC, NL, PT, RO, SE,
SI, SK, TR), OAPI patent (BF, BJ, CF, CG, CI, CM, GA,
GN, GQ, GW, ML, MR, NE, SN, TD, TG).

— *before the expiration of the time limit for amending the claims and to be republished in the event of receipt of amendments*

Published:

— *with international search report*

For two-letter codes and other abbreviations, refer to the "Guidance Notes on Codes and Abbreviations" appearing at the beginning of each regular issue of the PCT Gazette.

Title: Lightning protection of a pitch-controlled wind turbine blade

Technical Field

- 5 The invention relates to a wind turbine rotor including a rotor hub and a plurality of blades, and where each blade root is connected to said rotor hub through a pitch bearing in such a manner that the blade is pivotable about its longitudinal axis relative to the rotor hub, and where said blade is provided with at least one electrically conducting lightning down-conductor extending in the longitudinal direction of the
- 10 blade to the blade root and being electrically isolated from the pitch bearing, and where a spark gap is provided between the lightning down-conductor and the rotor hub, said spark gap being adapted to conduct a lightning current passing through the lightning down-conductor.
- 15 Furthermore, the invention relates to a wind turbine with the above wind turbine rotor.

Background Art

- 20 It is common knowledge that wind turbines are protected against lightning strikes, and it is also common knowledge that wind turbine blades are provided with lightning down-conductors arranged either on the outer surface of the blades or inside said blades. The latter type is provided with so-called lightning receptors, which are metallic through-going connections between the inner lightning down-conductor of
- 25 the blade and the outer surface of said blade. The purpose of these receptors is to "attract" the lightning so that the lightning current can be guided downwards through the lightning down-conductor mounted inside the wind turbine blade. Often, the wind turbine blades with externally mounted down-conductors are not provided with separate lightning receptors as said down-conductors act as receptors, per se.

Previous ways of solving the down-conducting of lightning have not specifically considered that a pitch bearing, if any, can be damaged by a strong lightning current, and typically the current is conducted through the down-conductor of the blade to the blade root and from there through the pitch bearing to the rotor hub. From the
5 rotor hub, the lightning current is conducted into the nacelle/turbine top section to the turbine tower and downwards into the ground.

One disadvantage of conducting the current through the pitch bearing is that bearing rollers etc. can be damaged by a strong lightning current generating electrical arcs
10 on its way down through the bearing with the result that a welding-like effect occurs which can damage the surface of the bearing. Once the surface of a bearing roller etc. has been damaged, the bearing is quickly worn down, which in time results in large repairs involving shut downs of the wind turbine. Even weak currents passing through the pitch bearing can cause small sparks and migration of material between
15 the pitch bearing members moving relative to each other.

The most common strikes of lightning occur when the potential difference between a negatively charged portion of a thundercloud and a positively charged area of the ground beneath the cloud grows sufficiently significant and causes a breakdown of
20 the isolation of the strata of air separating the areas of opposite electrical charge. The phenomenon also arises between a positively charged portion of a thundercloud and a negatively charged area on the ground.

Before the actual lightning strike can occur, a descending "channel" is generated,
25 also called a "leader", of negatively charged air molecules in the direction towards the ground. Often, the leader propagates gradually downwards in steps of 20 to 100 m and is therefore referred to as a "stepped leader". When this leader is sufficiently close to the ground, the intensified electrical field between the end of the descending leader and the ground generates one or more upward leaders of positively charged
30 air molecules towards the descending leader. These upward leaders usually extend upward from objects projecting from the ground, for example wind turbines, trees,

buildings, flag poles etc. When the two leaders meet, the system short-circuits and the actual main charge of the lightning, also referred to as a "return stroke" occurs. The phenomenon can likewise occur in reverse order, where the leader, also referred to as the "stepped leader", propagates from the ground or particularly high objects
5 on the ground and moves towards the charged area of the thundercloud.

DE 4436197 A1 discloses a solution where a lightning current is diverted from the pitch bearing and into the nacelle through a lightning conductor member defining spark gaps with the lightning down-conductor of the blade and an electrically con-
10 ducting ring on the nacelle, respectively. Electric arcs are generated by the lightning strikes in these spark gaps with the effect that the lightning current can be conducted downwards into the ground. Thus, electrical connections are only generated between the lightning down-conductor of the blade and the ground during the main charge of the actual lightning strike where electrical arcs are generated in the spark gaps. As
15 mentioned previously, leaders are generated prior to the actual main discharge, and the electrical isolation between the blade and the nacelle implies that there is a risk of the leaders passing through other uncontrollable paths between the individual structural members - for instance from the nacelle through the main shaft bearing or the rotor bearings to the rotor hub and from there through the pitch bearing of the
20 blade to the lightning down-conducting arrangement of the blade. Subsequent to the formation of electrical leaders passing through possible uncontrollable paths in for example the structural members, the main discharge of the lightning or parts thereof follows the path of the leader generated through the structure to the ground. Such a main discharge or parts thereof may cause minor or major damages on the structure
25 or parts thereof when it is not guided through a lightning down-conductor in a controllable way.

WO 01/86144 A1 discloses a wind turbine with a spark gap between a lightning down-conductor in the blade and the nacelle, and for where an electrical connection
30 exists between the lightning down-conductor and the rotor hub for a continuous

electrostatic discharge of the blade. In this structure, the pitch bearing of the blade is not protected against being passed by a discharge current.

Disclosure of Invention

5

The object of the invention is to provide an improved lightning down-conducting arrangement for a wind turbine which ensures to a maximum extent that the lightning strikes in the receptors of the blade or the outer lightning down-conductors so as subsequently to be guided safely to the ground through the lightning down-
10 conducting arrangement without causing damage to the wind turbine. A further object is to protect the pitch bearings against electrical currents.

The object of the invention is obtained by providing a sliding contact connection parallel to the spark gap between the lightning down-conductor and the rotor hub,
15 said sliding contact connection ensuring an electrical contact between said lightning down-conductor and said rotor hub irrespective of the pitch angle of the blade. In this way, a permanent electrical connection can be obtained between the lightning down-conductor of the blade and the rotor hub. Furthermore, upward leaders can be generated from the receptors of the blade or the outer lightning down-conductors
20 with the result that the probability of lightning striking in the receptor or in the outer lightning conductors has been optimised. During the actual main discharge, the so-called return stroke, where a very strong current flows within a very short period of time, an electric arc is simultaneously generated in the spark gap due to the very strong electrical potential applying after the short circuiting of the leaders. As a re-
25 sult the electrical resistance is very weak in the spark gap with the result that the lightning current passes through the spark gap to the ground. As the electrical resistance in the spark gap is much weaker than the contact resistance in the sliding contact connection, only a small non-destructive portion of the lightning current passes through the sliding contact connection. The sliding contact connection ensures that a
30 permanent electrical connection applies between the lightning down-conductor of the blade and the rotor hub irrespective of the pitch angle of the blade. The pitch

bearing is completely protected against the passing of current and is thereby ensured a prolonged life because no sparkovers and migrations of material occur between the pitch bearing members.

- 5 According to an advantageous embodiment, the sliding contact connection includes a collector shoe fixedly mounted on the rotor hub, and an electrically conducting contact member being connected to the lightning down-conductor of the blade and extending along a portion of the circumference of the blade root. This embodiment is particularly simple as the blade root is usually cylindrical, whereby the point of
10 contact between the contact member and the collector shoe is in a constant position, irrespective of the pitch angle of the blade.

According to an alternative embodiment, the sliding contact connection includes a collector shoe fixedly mounted on the blade root, and an electrically conducting con-
15 tact member in form of a rail mounted on the rotor hub.

According to a preferred embodiment, the spark gap is provided between the contact member and a spark gap member. This embodiment is particularly simple because the contact member is used for both the sliding contact connection and the spark gap
20 connection.

According to a particularly advantageous embodiment, the collector shoe and the spark gap member are combined in one contact unit, thereby obtaining a particularly simple and compact structure which is easily maintained or replaced.
25

The lightning down-conductor is advantageously connected to a lightning receptor adjacent the tip of the blade.

The invention also relates to a wind turbine including a nacelle, a rotor shaft and a
30 wind turbine rotor, as described above.

According to an embodiment, the rotor hub includes an electrically conducting rotor hub conductor which is connected to the portion of the spark gap arranged on rotor hub side, and which through an additional spark gap is connected to an electrically conducting nacelle conductor mounted on the nacelle.

5

The rotor hub conductor may be electrically connected to the portion of the slide contact connection arranged on the rotor hub side, and through an additional sliding contact connection said rotor hub connector may be connected to the nacelle conductor.

10

According to an embodiment, the nacelle conductor may be formed by an annular contact member arranged coaxially with the rotor shaft, the rotor hub conductor being connected to an additional spark gap member and an additional collector shoe which defines the additional spark gap and the additional sliding contact connection, respectively, between the nacelle conductor and the annular contact member.

15

The rotor hub conductor may be electrically isolated from the rotor shaft.

Brief Description of the Drawings

20

The invention is explained in detail below by means of a preferred embodiment shown in the drawings, in which

Fig. 1 is a side view of a principle sketch of a wind turbine,

25

Fig. 2 is a detailed view of a rotor hub for a wind turbine, portions of two blades being shown,

Fig. 3 is a detailed sectional view of a rotor hub and a blade with a lightning down-
conducting arrangement, and

30

Fig. 4 is a detailed view showing an embodiment of a lightning down-conducting arrangement according to the invention.

The Figures 1 to 4 described below are designated the following reference numerals:

5		
	1	Wind turbine tower
	2	Nacelle/turbine top section
	3	Rotor hub
	4	Blade
10	5	Pitch bearing
	6	Inner lightning down-conductor
	7	Contact member
	8	Contact unit
	9	Mounting arm for the contact unit
15	10	Mounting fittings
	11	Spark gap member
	12	Collector shoe
	13	Mounting plate for the spark gap member and the collector shoe
	14	Spacer
20	15	Spark gap
	16	Blade root
	17	Rotor shaft

Best Modes for Carrying out the Invention

25

Fig. 1 shows a wind turbine where a nacelle/turbine top section 2 is conventionally mounted on the tower 1, a generator and a gear being mounted in said nacelle. A rotor shaft 17 projects from the nacelle 2, the rotor hub 3 of the wind turbine being mounted on said rotor shaft. The blades 4 of the wind turbine are mounted on the rotor hub 3.

30

Fig. 2 shows a detailed view of a rotor hub 3 for a wind turbine as well as portions of two blades 4. In the structure shown, the blades 4 and the rotor hub 3 are connected through pitch bearings 5, and the position of the blades 4 is adjustable about their longitudinal axes, i.e. the pitch angle, by means of said bearings.

5

In order to intercept and guide a lightning strike to the ground, an inner lightning down-conductor 6 is mounted inside the blade 4, cf. Fig. 3, said lightning down-conductor being connected at the tip of the blade 4 to one or more lightning receptors not shown. Adjacent the pitch bearing 5, this inner lightning down-conductor 6
10 is in direct electrical contact with a contact member 7 mounted on the outer side of the blade 4 in the embodiment shown. This contact member 7 presents an abutment face for an externally mounted contact unit 8 having a spark gap device and a sliding device fixedly mounted on the rotor hub 3 through a mounting arm 9 and mounting fittings 10.

15

Fig. 4 shows in detail how a contact unit 8 includes a mounting plate 13, a spark gap member 11 and a collector shoe 12 being mounted on said mounting plate 13. The contact unit 8 is mounted at the end of the mounting arm 9 in such a manner that the contact unit 8 subjects the surface of the contact member 7 to an elastic force. In order to prevent the spark gap member 11 from coming into direct contact with the
20 contact face 7, spacers 14 are mounted between the mounting plate 13 and said contact face 7.

The contact member 7 is typically made of metal and can be shaped as an elongated
25 member of a height - seen in the longitudinal direction of the blade - typically smaller than the width of the member. This member can be mounted flatly on the cylindrical surface of the blade root 16 and is connected to the inner lightning down-conductor 6 in the blade.

30 Together the spark gap member 11, the contact member 7 and the spacers 14 define a spark gap 15 of 1 to 10 mm. The surface of the spark gap member 11 facing the

contact member 7 is serrated as shown. As a result, the concentrations of the flux lines around the tips of the spark gap member are reinforced, which facilitates the ignition of the electric arc in the spark gap.

- 5 The contact member 7 can extend all the way round the cylindrical blade root 16, but in principle it need only extend over 90° to 100° of the circumference of the blade root, which corresponds to the usually adjustable interval of the blade.

The collector shoe 7 can be made of a carbon brush or be shaped as a brush or a
10 spring-loaded shoe and be made of for example graphite, bronze, brass or carbon fibre.

According to an alternative embodiment of an arrangement as herein described, the entire arrangement can be reversed so that the collector shoe 17 and the spark gap
15 member 11 are mounted on the blade, and the contact member 7 is mounted on the rotor hub. Thus, the contact member 7 can be shaped as a curved rail extending parallel to and at a distance from the surface of the blade root. Furthermore, the arrangement can function as both an inner solution where the entire equipment is mounted inside the blade and the rotor hub, or on the outer face of said blade and the
20 rotor hub as described above.

The contact member 7 is shaped so that the pitch angle of the blade is freely adjustable while maintaining a good electrical connection. This good electrical connection is necessary for ensuring the formation of leaders from the receptors of the blade in
25 connection with lightning strikes. The electrical connection also protects against unintentional spark flashovers in other places in the structure while ensuring a controlled discharge of static charges from the blade to the rotor hub, said charges being generated by the rotation of the blade through the air.

- 30 The electrical potential of the leader is present during initial stage of the lightning process and is not always sufficiently high for generating an electric arc in the spark

gap 15, but passes instead through the sliding device. When the leader has "intercepted" a lightning, the electrical potential across the distance in the spark gap is sufficient for breaking down the isolation between the spark gap member and the contact member 7 of the blade due to the strong increase in the electrical potential during the main discharge of the lightning. As a result an electric arc is lit between the spark gap member 11 and the contact member 7. During the entire discharge period of the main discharge, the electric arc presents a weaker electrical resistance than the sliding device, whereby the main discharge is discharged across the spark gap. Therefore the sliding device is protected during the main discharge phase due to the increased electrical resistance thereof compared to the lit spark gap.

It is possible to guide the current applying during the initial stage of the lightning process and during the actual main discharge to the ground through the rotor shaft 17, further on from the rotor shaft to the nacelle 2 through the shaft bearing or a sliding contact connection, from the nacelle to the tower through the yaw bearing or yet another sliding contact connection, and through the tower down to the ground. A spark gap can also be established between the rotor shaft 17 and the nacelle 2 and between the nacelle and the tower.

Alternatively, an additional spark gap connection and an additional sliding contact connection 2 can be established between the rotor hub 3 and the nacelle 2. The spark gap connection and the sliding contact connection between the blade 4 and the rotor hub 3 and the additional spark gap connection and the additional sliding contact connection between the rotor hub 3 and the nacelle 2 can thus be interconnected through a rotor hub conductor electrically isolated from the rotor shaft 17. In this way, it is avoided that current flows in the rotor shaft with the effect that the bearings of the rotor shaft are not strained.

It is also possible to establish a spark gap connection and a sliding contact connection in parallel between the nacelle 2 and the tower 1.

The invention is not limited to the above embodiments.

Claims

1. A wind turbine rotor including a rotor hub (3) and a plurality of blades (4), and where each blade root (16) is connected to said rotor hub through a pitch bearing (5)
5 in such a manner that the pitch angle of the blade is adjustable by a turning of the blade about its longitudinal axis relative to the rotor hub, and where the blade is provided with at least one electrically conducting lightning down-conductor (6) extending in the longitudinal direction of the blade to the blade root and being electrically isolated from the pitch bearing (5), and where a spark gap (15) is provided be-
10 tween the lightning down-conductor and the rotor hub, said spark gap (15) being adapted to conduct a lightning current passing through the lightning down-conductor, **characterised in that** a sliding contact connection (7, 12) is provided parallel to the spark gap (15) between the lightning down-conductor (6) and the rotor hub (3), said sliding contact connection ensuring electrical contact between said
15 lightning down-conductor (6) and said rotor hub (3) irrespective of the pitch angle of the blade.
2. A wind turbine rotor according to claim 1, **characterised in that** the sliding contact connection includes a collector shoe (12) fixedly mounted on the rotor hub
20 (3), and an electrically conducting contact member (7) connected to the lightning down-conductor (6) of the blade and extending along a portion of the circumference of the blade root (16).
3. A wind turbine rotor according to claim 1, **characterised in that** the sliding contact connection includes a collector shoe (12) fixedly mounted on the blade root
25 (16), and an electrically conducting contact member (7) in form of a rail mounted on the rotor hub (3).
4. A wind turbine rotor according to claim 2 or 3, **characterised in that** the spark
30 gap (15) is provided between the contact member (7) and a spark gap member (11).

5. A wind turbine rotor according to claim 4, **characterised in that** the collector shoe (12) and the spark gap member (11) are combined in one contact unit (8).
6. A wind turbine rotor according to one of the preceding claims, **characterised**
5 **in that** the lightning down-conductor (6) is connected to a lightning receptor adjacent the tip of the blade.
7. A wind turbine including a nacelle (2), a rotor shaft (17) and a wind turbine rotor according to one of the preceding claims.
- 10
8. A wind turbine according to claim 7, **characterised in that** the rotor hub (3) includes an electrically conducting rotor hub conductor connected to the part (7; 11) of the spark gap (15) which is arranged on the rotor hub side, said rotor hub conductor further being connected through an additional spark gap to an electrically con-
15 ducting nacelle conductor mounted on the nacelle (2).
9. A wind turbine according to claim 8, **characterised in that** the rotor hub conductor is electrically connected to the part (7; 12) of the slide contact connection which is arranged on the rotor hub side, said rotor hub conductor further being con-
20 nected to the nacelle conductor through an additional sliding contact connection.
10. A wind turbine according to claim 9, **characterised in that** the nacelle conductor includes an annular contact member arranged coaxially with the rotor shaft (17), and that the rotor hub conductor is connected to an additional spark gap member and
25 an additional collector shoe which defines the additional spark gap and the additional sliding contact connection, respectively, between the nacelle conductor and the annular contact member.
11. A wind turbine according to one of the claims 8 to 10, **characterised in that** the
30 rotor hub conductor is electrically isolated from the rotor shaft (17).

1/4

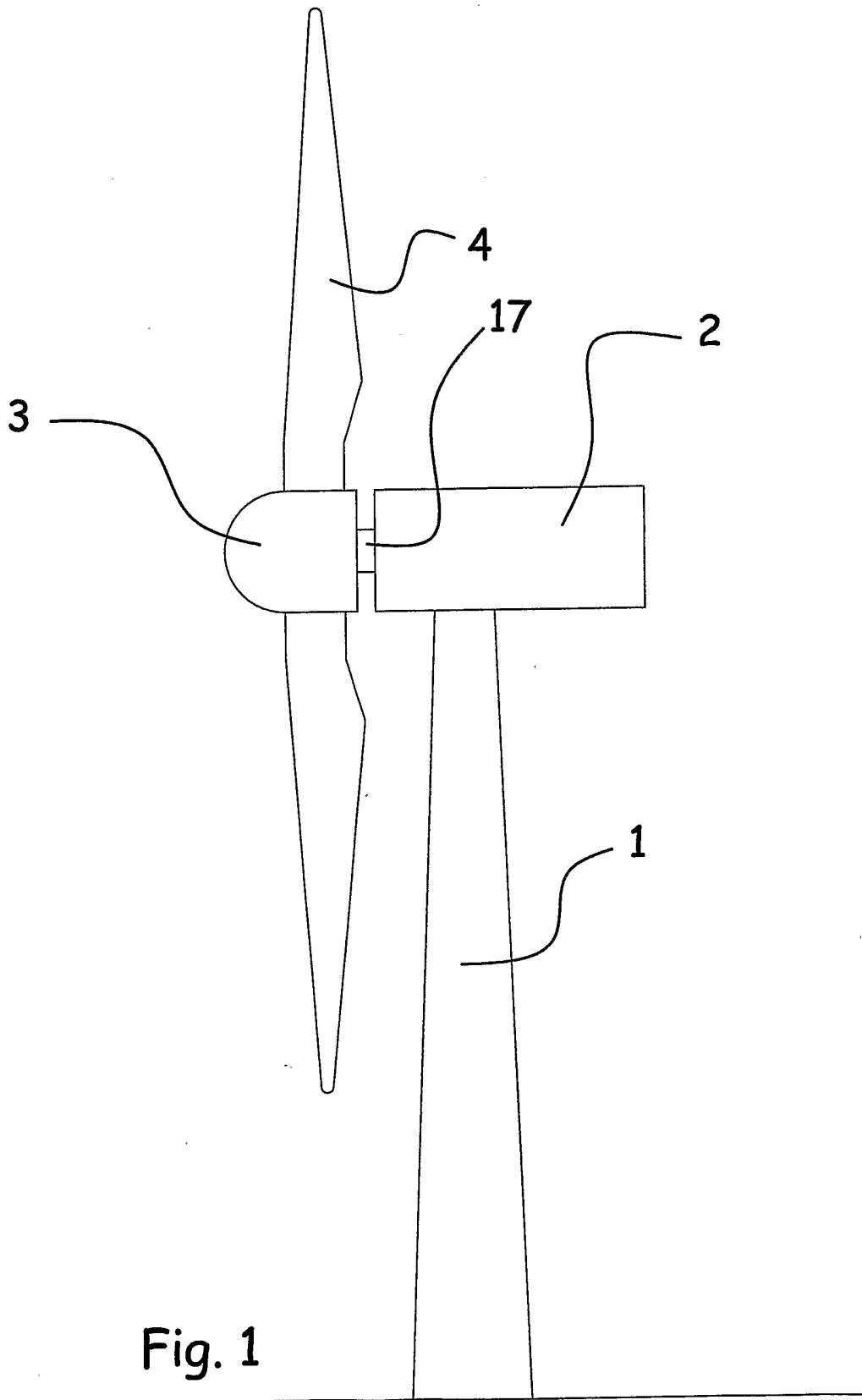

Fig. 1

2/4

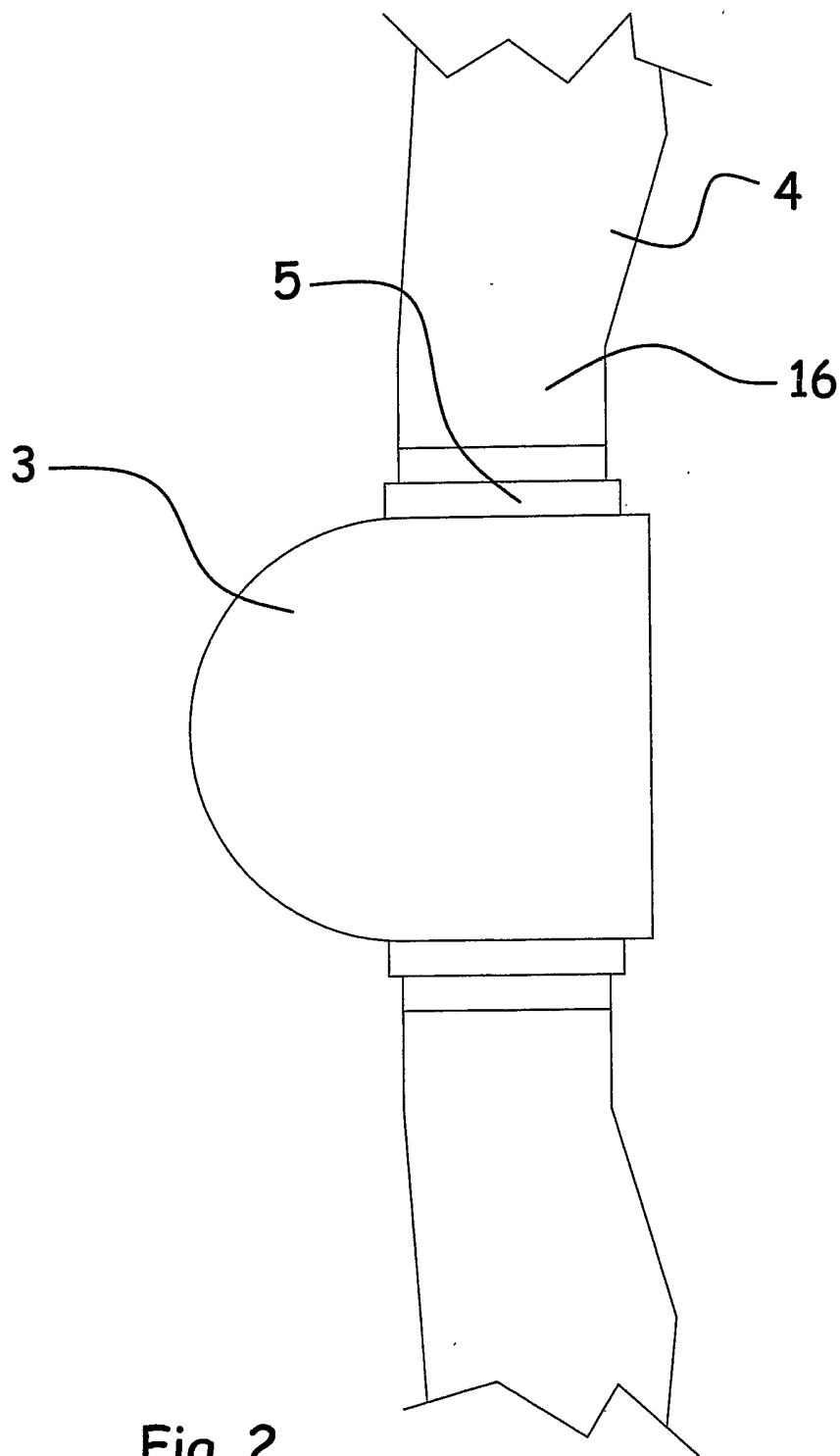

Fig. 2

3/4

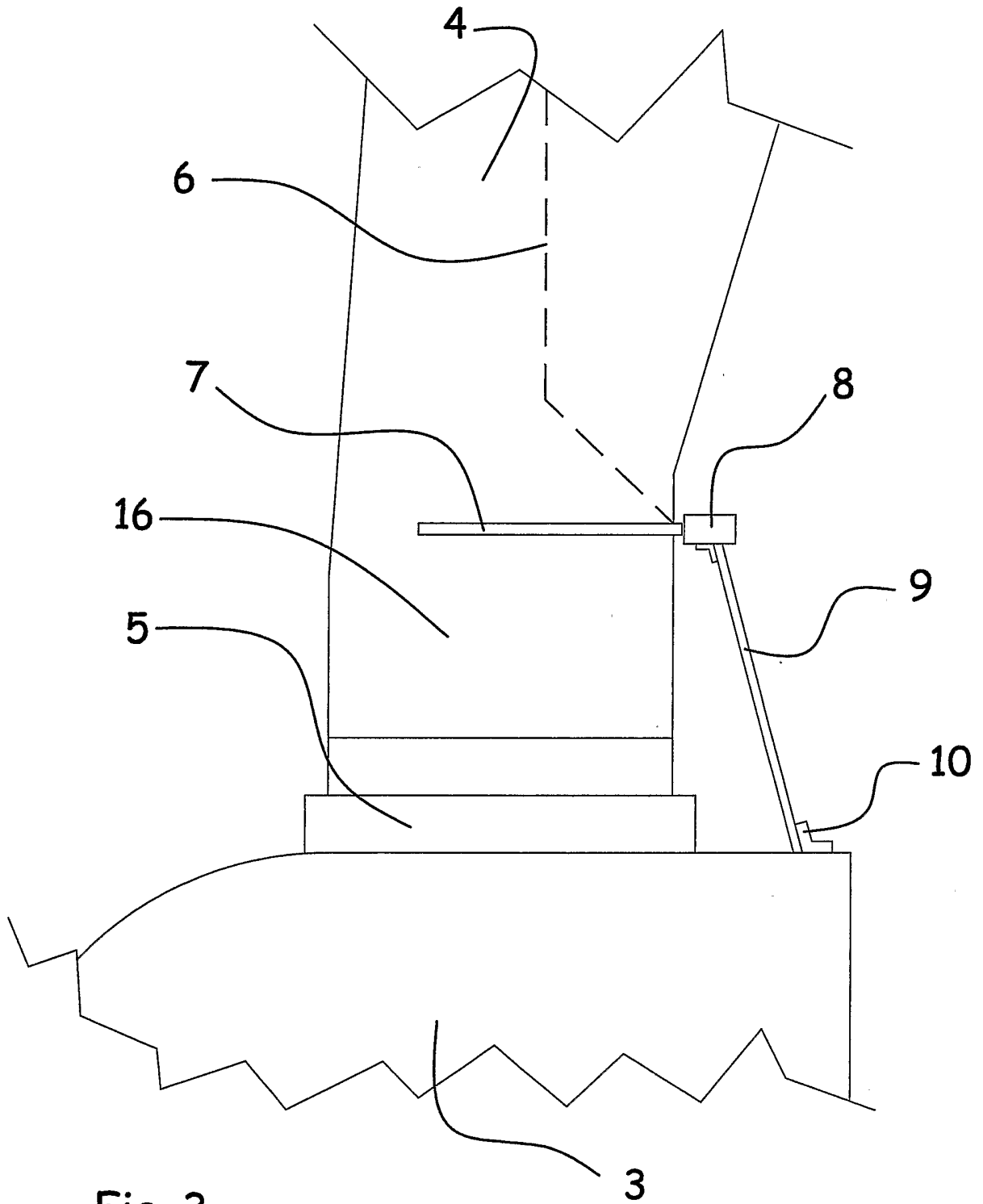

Fig. 3

4/4

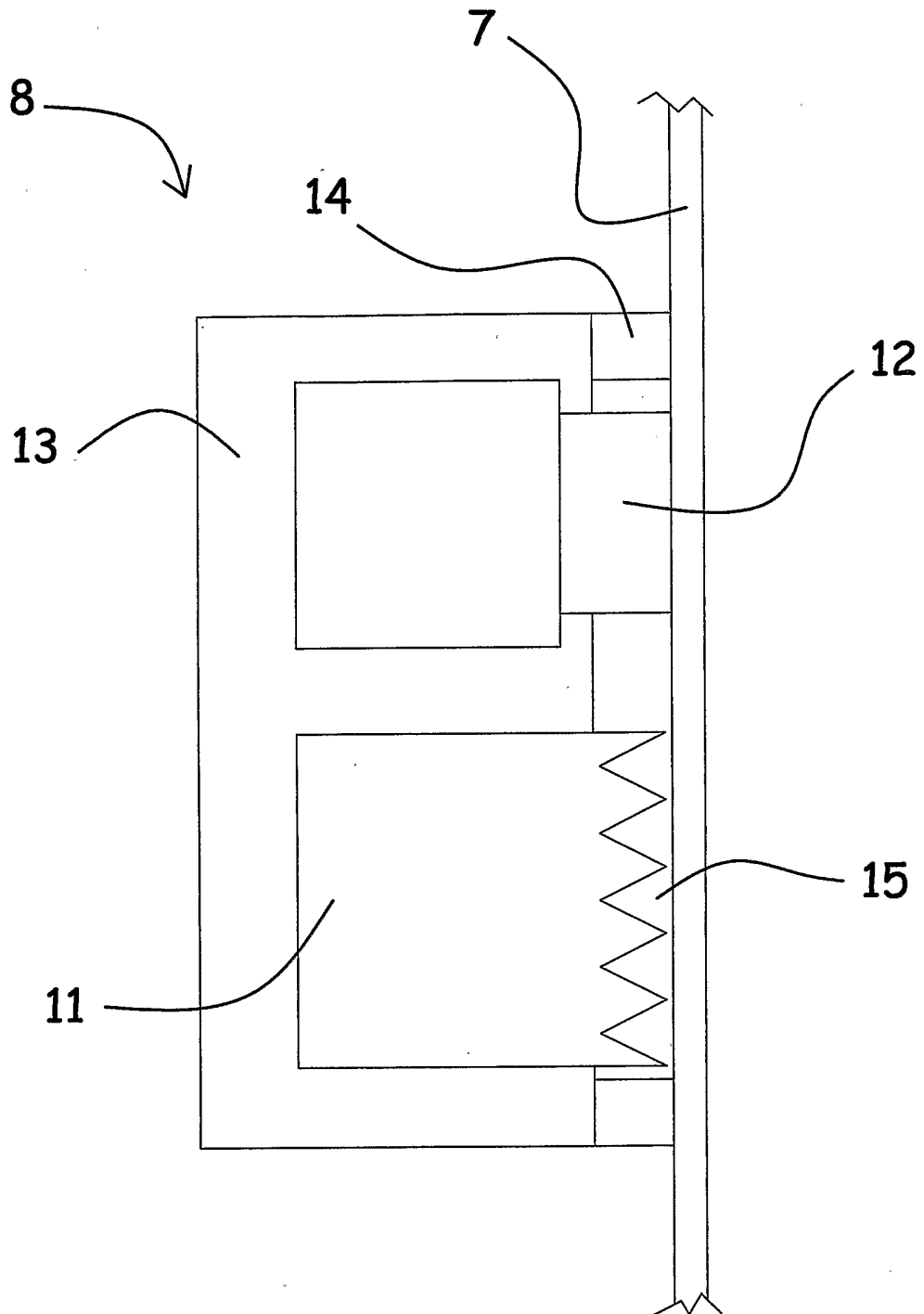

Fig. 4

INTERNATIONAL SEARCH REPORT

International Application No
PCT/DK 03/00778

A. CLASSIFICATION OF SUBJECT MATTER
IPC 7 F03D11/00 H02G13/00

According to International Patent Classification (IPC) or to both national classification and IPC

B. FIELDS SEARCHED

Minimum documentation searched (classification system followed by classification symbols)
IPC 7 F03D H02G

Documentation searched other than minimum documentation to the extent that such documents are included in the fields searched

Electronic data base consulted during the international search (name of data base and, where practical, search terms used)

EPO-Internal, WPI Data, PAJ

C. DOCUMENTS CONSIDERED TO BE RELEVANT

Category °	Citation of document, with indication, where appropriate, of the relevant passages	Relevant to claim No.
A	WO 01 86144 A (WOBLEN ALOYS) 15 November 2001 (2001-11-15) page 6, paragraph 4 -page 7, paragraph 1; claims 3,18 ---	1-11
A	EP 1 036 937 A (HITACHI ENG SERVICE ;HITACHI LTD (JP)) 20 September 2000 (2000-09-20) figure 2 ---	1
A	EP 0 718 495 A (AUTOFLUG ENERGIETECH GMBH) 26 June 1996 (1996-06-26) column 2, paragraph 4 - paragraph 5 ---	1
A	EP 0 707 145 A (AUTOFLUG ENERGIETECH GMBH) 17 April 1996 (1996-04-17) column 4, line 55 -column 5, line 8 -----	1-11

Further documents are listed in the continuation of box C.

Patent family members are listed in annex.

° Special categories of cited documents :

- "A" document defining the general state of the art which is not considered to be of particular relevance
- "E" earlier document but published on or after the international filing date
- "L" document which may throw doubts on priority claim(s) or which is cited to establish the publication date of another citation or other special reason (as specified)
- "O" document referring to an oral disclosure, use, exhibition or other means
- "P" document published prior to the international filing date but later than the priority date claimed

- "T" later document published after the international filing date or priority date and not in conflict with the application but cited to understand the principle or theory underlying the invention
- "X" document of particular relevance; the claimed invention cannot be considered novel or cannot be considered to involve an inventive step when the document is taken alone
- "Y" document of particular relevance; the claimed invention cannot be considered to involve an inventive step when the document is combined with one or more other such documents, such combination being obvious to a person skilled in the art.
- "&" document member of the same patent family

Date of the actual completion of the international search

11 March 2004

Date of mailing of the international search report

29. 03. 2004

Name and mailing address of the ISA

European Patent Office, P.B. 5818 Patentlaan 2
NL - 2280 HV Rijswijk
Tel. (+31-70) 340-2040, Tx. 31 651 epo nl,
Fax: (+31-70) 340-3016

Authorized officer

ANNETTE RIEDEL / ELY

INTERNATIONAL SEARCH REPORT

International Application No

PCT/DK 03/00778

Patent document cited in search report		Publication date	Patent family member(s)	Publication date
WO 0186144	A	15-11-2001	DE 10022128 C1	20-12-2001
			AU 4418201 A	20-11-2001
			BR 0110646 A	25-03-2003
			CA 2408295 A1	15-11-2001
			CN 1436283 T	13-08-2003
			WO 0186144 A1	15-11-2001
			EP 1282775 A1	12-02-2003
			JP 2003532836 T	05-11-2003
			NO 20025297 A	05-11-2002
			TR 200202455 T2	21-02-2003
			US 2003170122 A1	11-09-2003
			ZA 200209218 A	09-07-2003

EP 1036937	A	20-09-2000	JP 2000265938 A	26-09-2000
			EP 1036937 A2	20-09-2000
			US 6407900 B1	18-06-2002

EP 0718495	A	26-06-1996	DE 4445899 A1	27-06-1996
			DE 19501267 A1	29-08-1996
			EP 0718495 A1	26-06-1996

EP 0707145	A	17-04-1996	DE 4436290 C1	02-05-1996
			EP 0707145 A1	17-04-1996
