



US00D354105S

United States Patent [19]

[11] Patent Number: **Des. 354,105**

Meibock et al.

[45] Date of Patent: **** Jan. 3, 1995**

[54] **IN-LINE ROLLER SKATE FRAME**

[75] Inventors: **Antonin A. Meibock**, Cleveland, Ohio; **John E. Svensson**, Seattle, Wash.

[73] Assignee: **K-2 Corporation**, Vashon, Wash.

[**] Term: **14 Years**

[21] Appl. No.: **17,352**

[22] Filed: **Jan. 11, 1994**

5,028,058	7/1991	Olsen	280/11.22
5,046,746	9/1991	Gierveld	280/11.22
5,048,848	9/1991	Olson et al.	280/11.22
5,088,748	2/1992	Koselka	280/11.22
5,092,614	3/1992	Malewicz	280/11.22
5,129,663	7/1992	Soo	280/7.14
5,192,088	3/1993	Yu	280/11.22
5,193,827	3/1993	Olsen	280/11.22
5,226,673	7/1993	Cech	280/11.22
5,253,884	10/1993	Landers	280/11.22

Related U.S. Application Data

[63] Continuation-in-part of Ser. No. 94,576, Jul. 19, 1993, and a continuation-in-part of Ser. No. 100,745, Aug. 2, 1993, and a continuation-in-part of Ser. No. 120,629, Sep. 13, 1993.

[52] U.S. Cl. **D21/226**

[58] Field of Search **D21/224-226; D2/904; 280/11.2, 11.22, 11.23, 11.27**

References Cited

U.S. PATENT DOCUMENTS

D. 321,393	11/1991	Olson et al.	D21/226
D. 323,540	1/1992	Graham	D21/225
D. 324,713	3/1992	Rubin	D21/226
D. 334,225	3/1993	Graham	D21/226
D. 346,192	4/1994	Miller	D21/226
1,868,548	7/1932	Turner	.
3,287,023	11/1966	Ware	.
4,909,523	3/1990	Olson	280/11.2

Primary Examiner—Bernard Ansher
Assistant Examiner—R. Barkai
Attorney, Agent, or Firm—Christensen, O'Connor, Johnson & Kindness

CLAIM

[57] The ornamental design for an in-line roller skate frame, as shown and described.

DESCRIPTION

FIG. 1 is a right front perspective view of an in-line roller skate frame showing our new design; FIG. 2 is a right side elevational view thereof, the side opposite being a mirror image; FIG. 3 is a top plan view thereof; FIG. 4 is a bottom plan view thereof; FIG. 5 is a rear elevational view thereof; and, FIG. 6 is a front elevational view thereof. The broken line showing of the boot and wheels in FIG. 2 is for illustrative purposes only and forms no part of the claimed design.

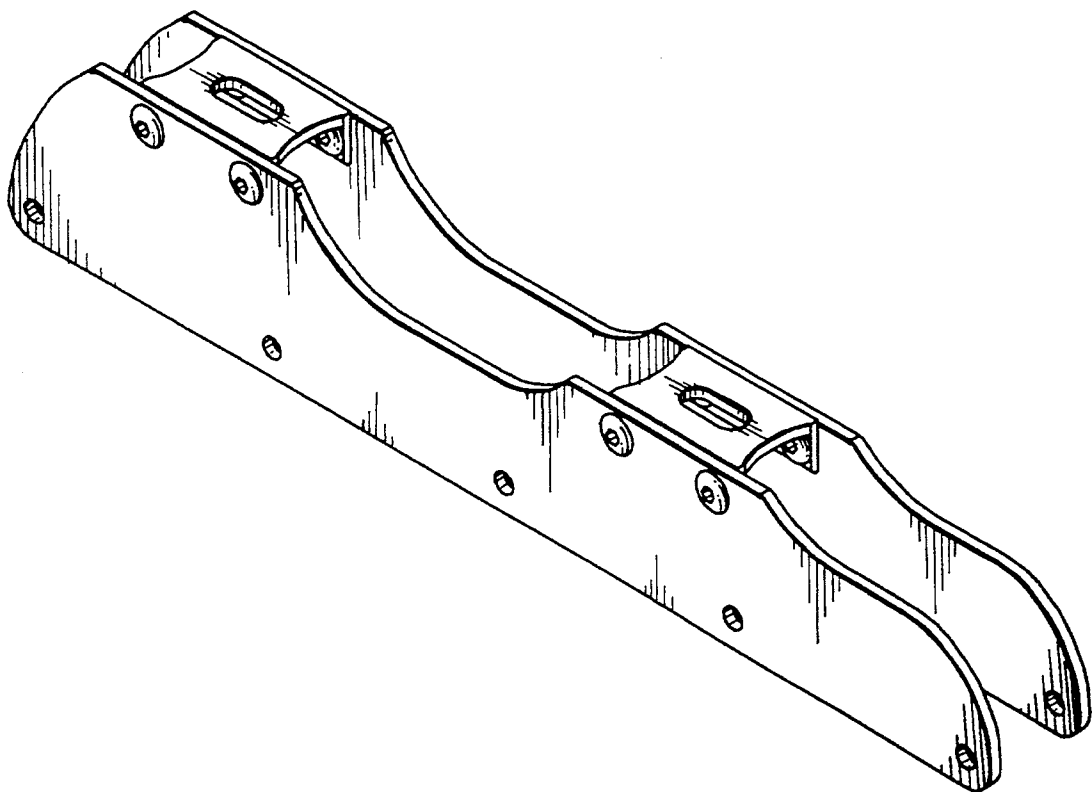

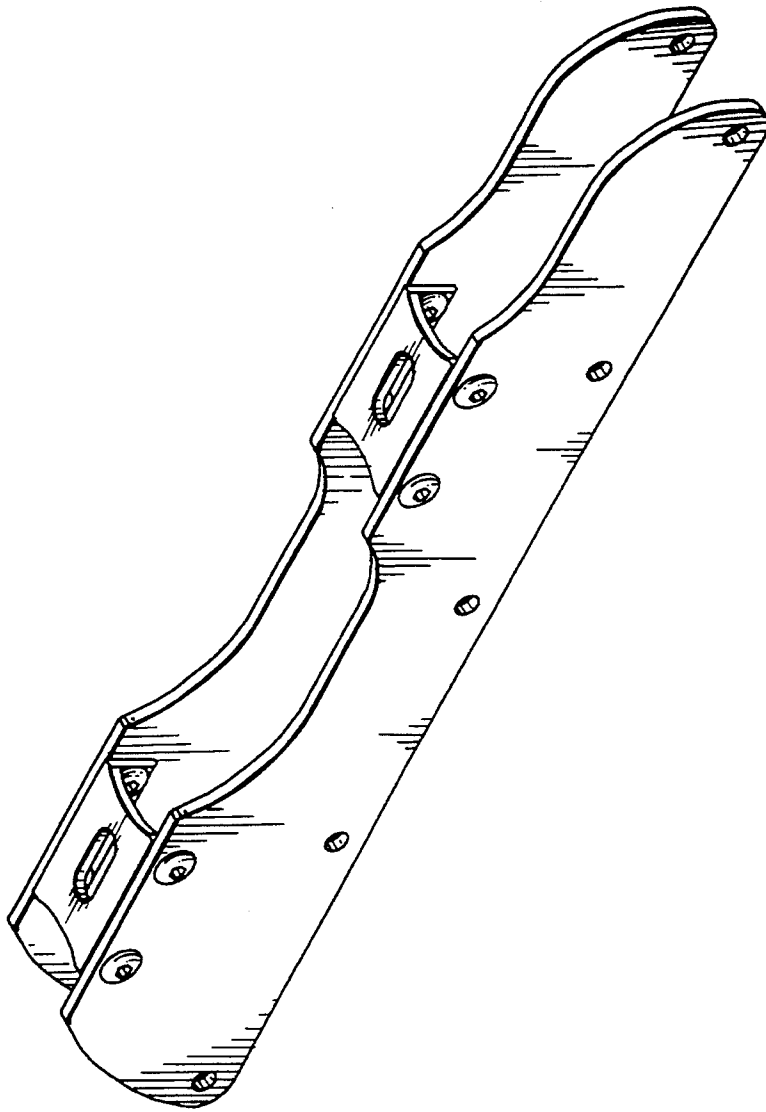

FIG. 1.

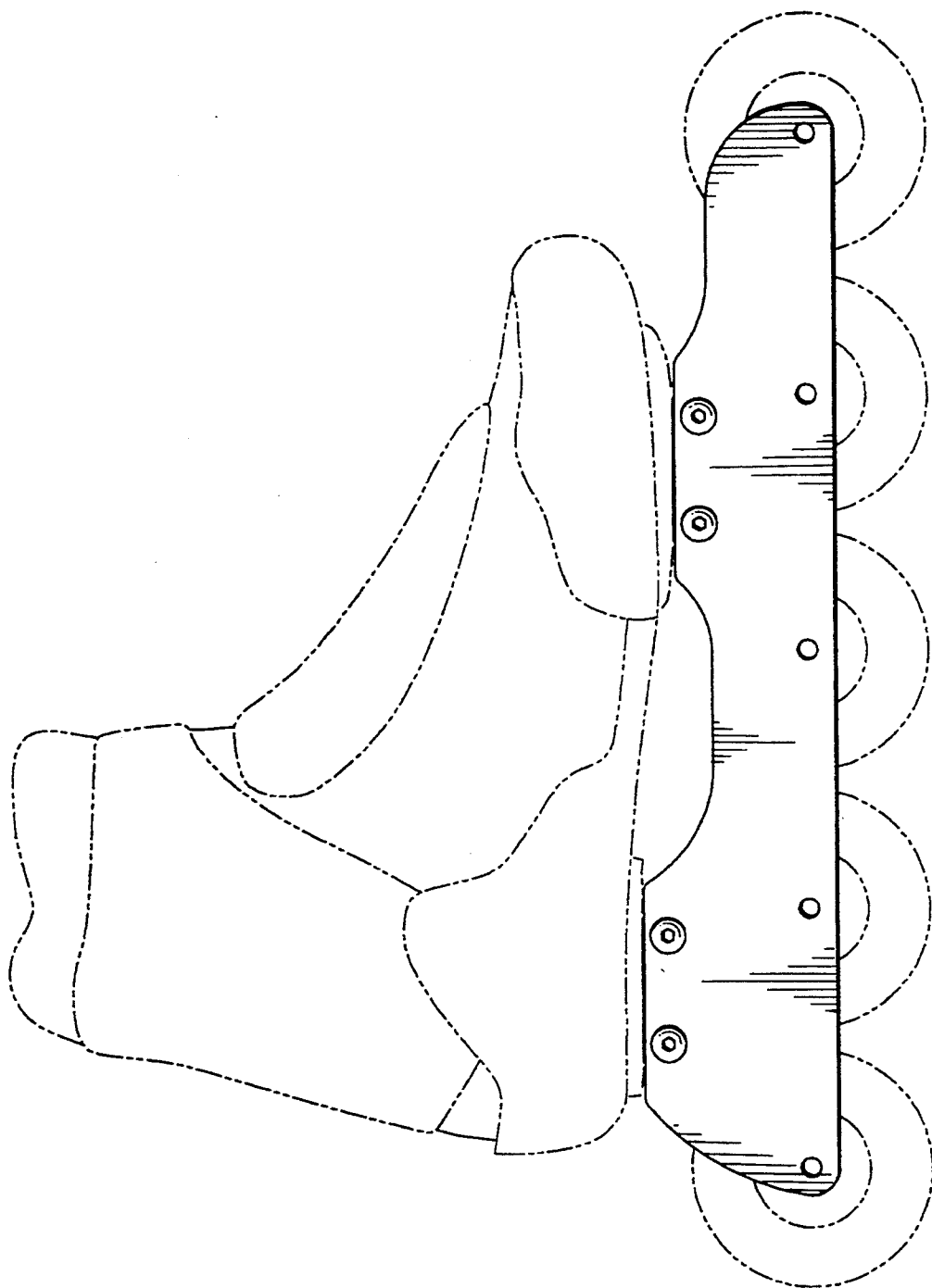

FIG. 2.

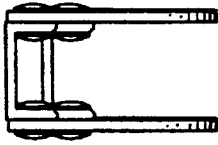

FIG. 5.

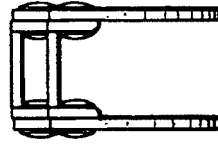

FIG. 6.

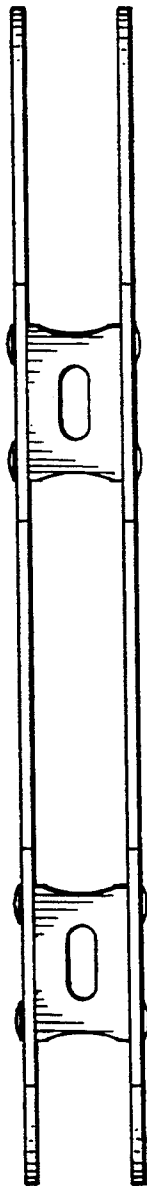

FIG. 3.

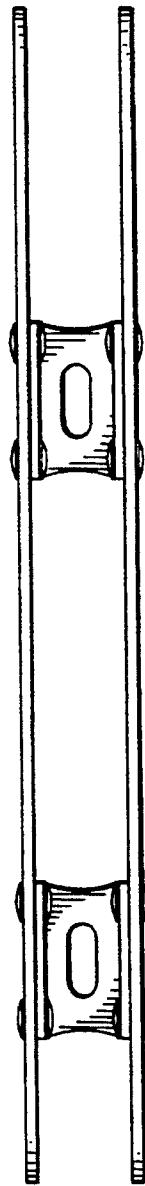

FIG. 4.