



US009270395B2

(12) **United States Patent**
Zheng et al.

(10) **Patent No.:** **US 9,270,395 B2**
(45) **Date of Patent:** **Feb. 23, 2016**

(54) **METHOD FOR ROBUST PTP SYNCHRONIZATION WITH DEFAULT 1588V2 PROFILE**

FOREIGN PATENT DOCUMENTS

CN 103051407 A 4/2013
WO 2013189536 A1 12/2013

(71) Applicant: **Telefonaktiebolaget L M Ericsson (publ)**, Stockholm (SE)

OTHER PUBLICATIONS

(72) Inventors: **Qun Zheng**, Surrey (CA); **Thomas Geyer**, Langley (CA)

Takahide Murakami et al., "A Master Redundancy Technique in IEEE 1588 Synchronization with a Link Congestion Estimation," Sep. 27, 2010, pp. 30-35, 2010 International IEEE Symposium on Precision Clock Synchronization for Measurement Control and Communication (ISPCS), IEEE.

(73) Assignee: **Telefonaktiebolaget L M Ericsson (publ)**, Stockholm (SE)

IEEE 1588-2002 "Standard for a Precision Clock Synchronization Protocol for Networked Measurement and Control Systems"; (Nov. 8, 2002), 154 pages.

(*) Notice: Subject to any disclaimer, the term of this patent is extended or adjusted under 35 U.S.C. 154(b) by 95 days.

IEEE 1588-2008 "Standard for a Precision Clock Synchronization Protocol for Networked Measurement and Control Systems"; (Jul. 24, 2008), 289 pages.

(21) Appl. No.: **14/269,786**

ITU-T G.8265.1 Y.1365.1-2010 "Precision Time Protocol Telecom Profile for Frequency Synchronization", *International Telecommunication Union (ITU)*, (Oct. 1, 2010), 20 pages.

(22) Filed: **May 5, 2014**

(65) **Prior Publication Data**

* cited by examiner

US 2015/0318941 A1 Nov. 5, 2015

(51) **Int. Cl.**
H04J 3/06 (2006.01)

Primary Examiner — Andrew Lai

Assistant Examiner — Jamaal Henson

(52) **U.S. Cl.**
CPC **H04J 3/0641** (2013.01); **H04J 3/0667** (2013.01); **H04J 3/0697** (2013.01); **H04J 3/0658** (2013.01)

(74) *Attorney, Agent, or Firm* — Nicholson de Vos Webster & Elliott, LLP

(58) **Field of Classification Search**
USPC 370/503
See application file for complete search history.

(57) **ABSTRACT**

Exemplary methods for reducing sync time in a precision time protocol (PTP) network include receiving, by a first PTP slave port of a first network device, timing messages from a second PTP master port of a second network device. The methods include maintaining a PTP master clock based on timing information included in the timing messages received from the second network device via the first PTP port. The methods further include receiving, by a third PTP passive port of the first network device, timing messages from a fourth PTP master port of a third network device. The methods include determining the third PTP passive port is a protective passive port based on a stepsRemoved value of the third network device, and maintaining an auxiliary clock based on the timing information included in the timing messages received from the third network device via the third PTP port.

(56) **References Cited**

24 Claims, 10 Drawing Sheets

U.S. PATENT DOCUMENTS

9,137,767 B1 * 9/2015 Guthrie H04W 56/0015
2011/0150476 A1 * 6/2011 Zhao H04J 3/0655
398/63
2011/0261917 A1 * 10/2011 Bedrosian H04J 3/0667
375/371
2013/0301634 A1 * 11/2013 Ehlers H04L 12/4625
370/350
2013/0336117 A1 * 12/2013 Yan H04J 3/0667
370/235

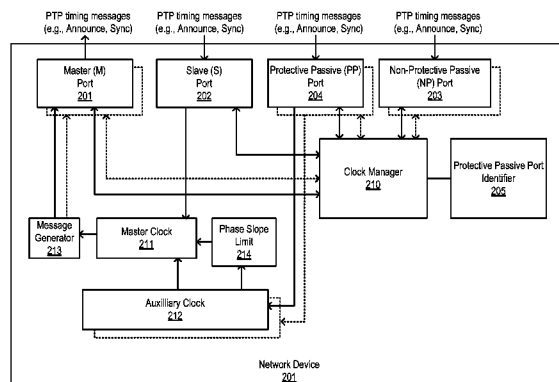

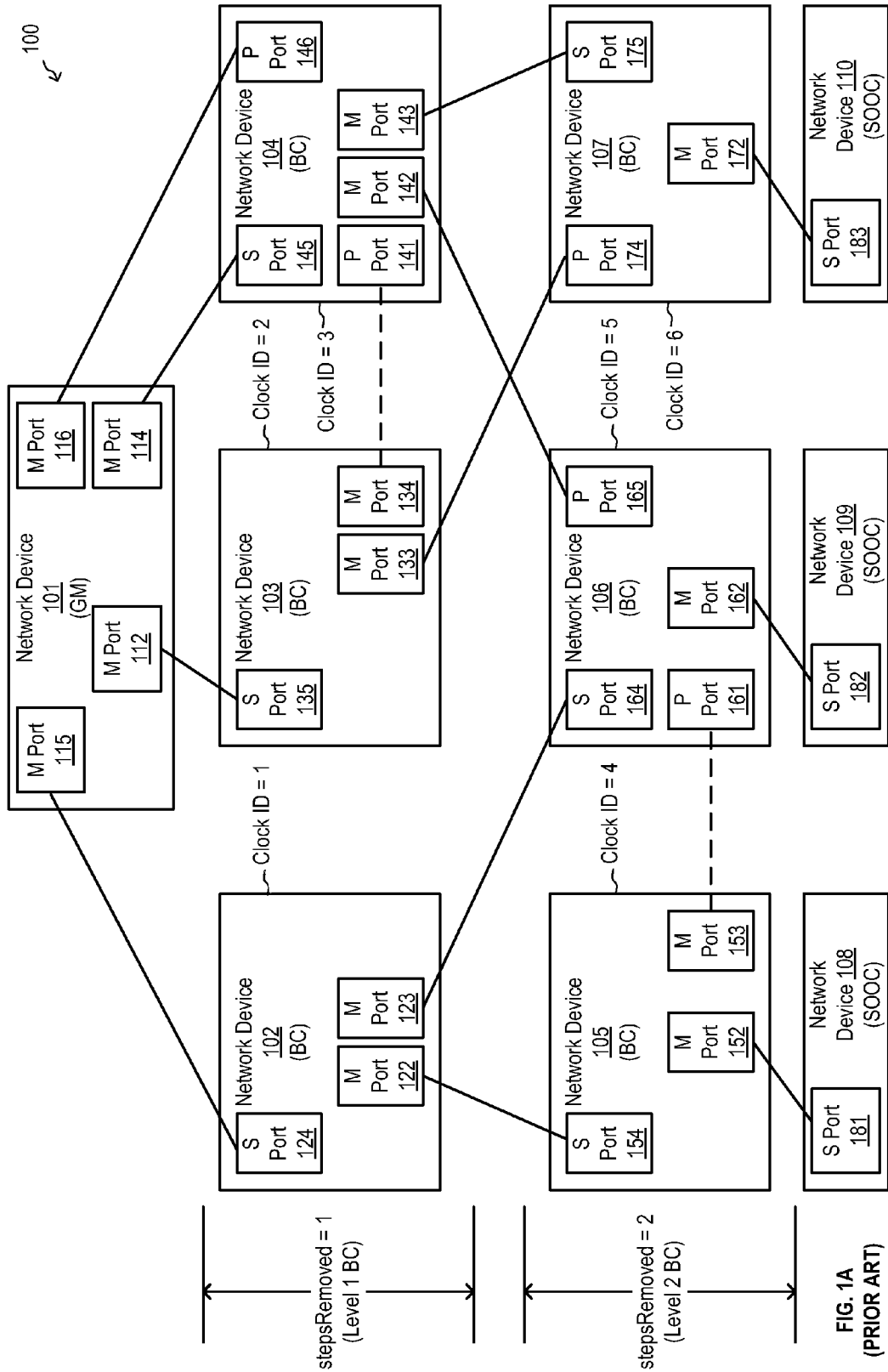

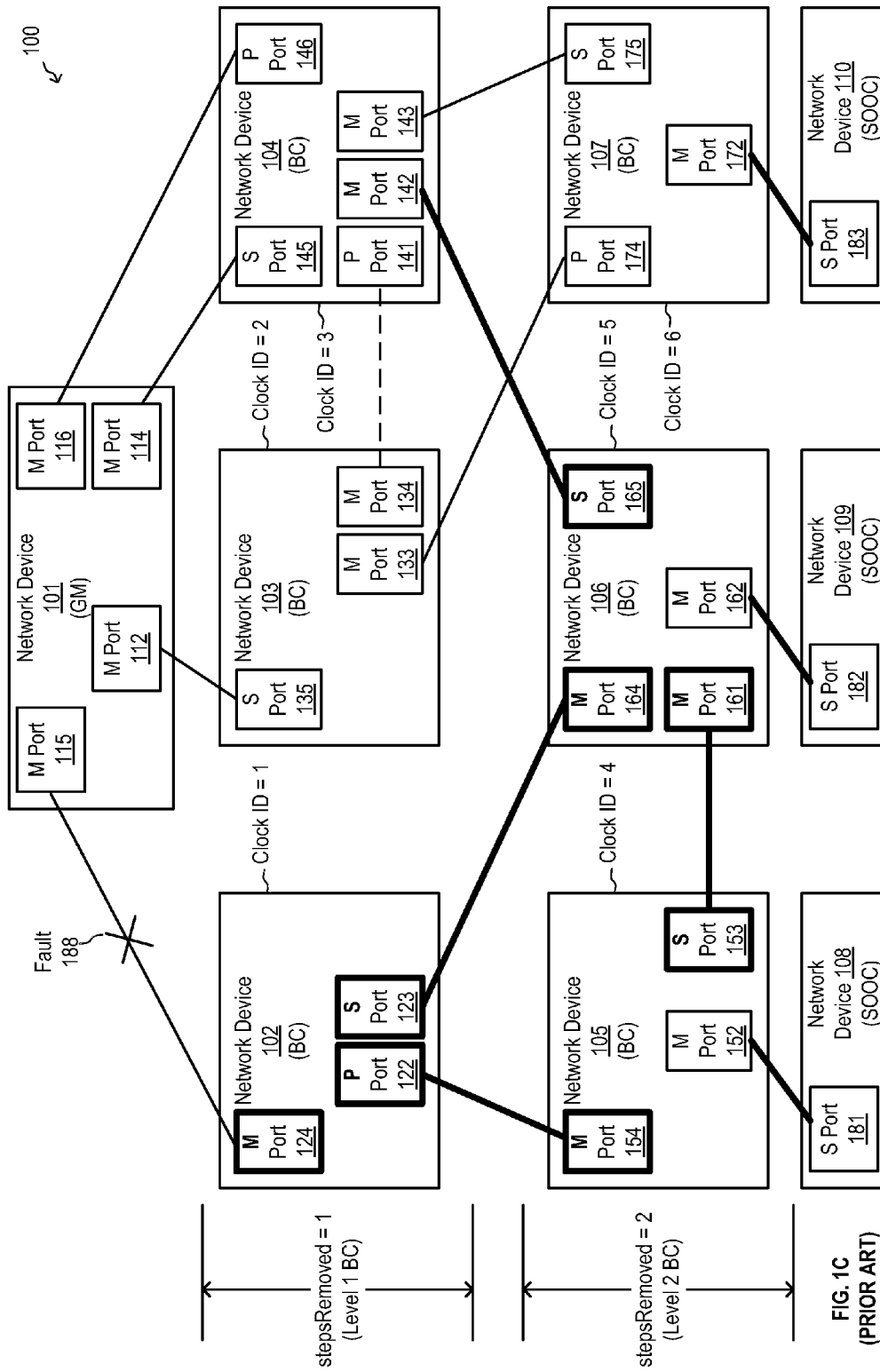

FIG. 1C
(PRIOR ART)

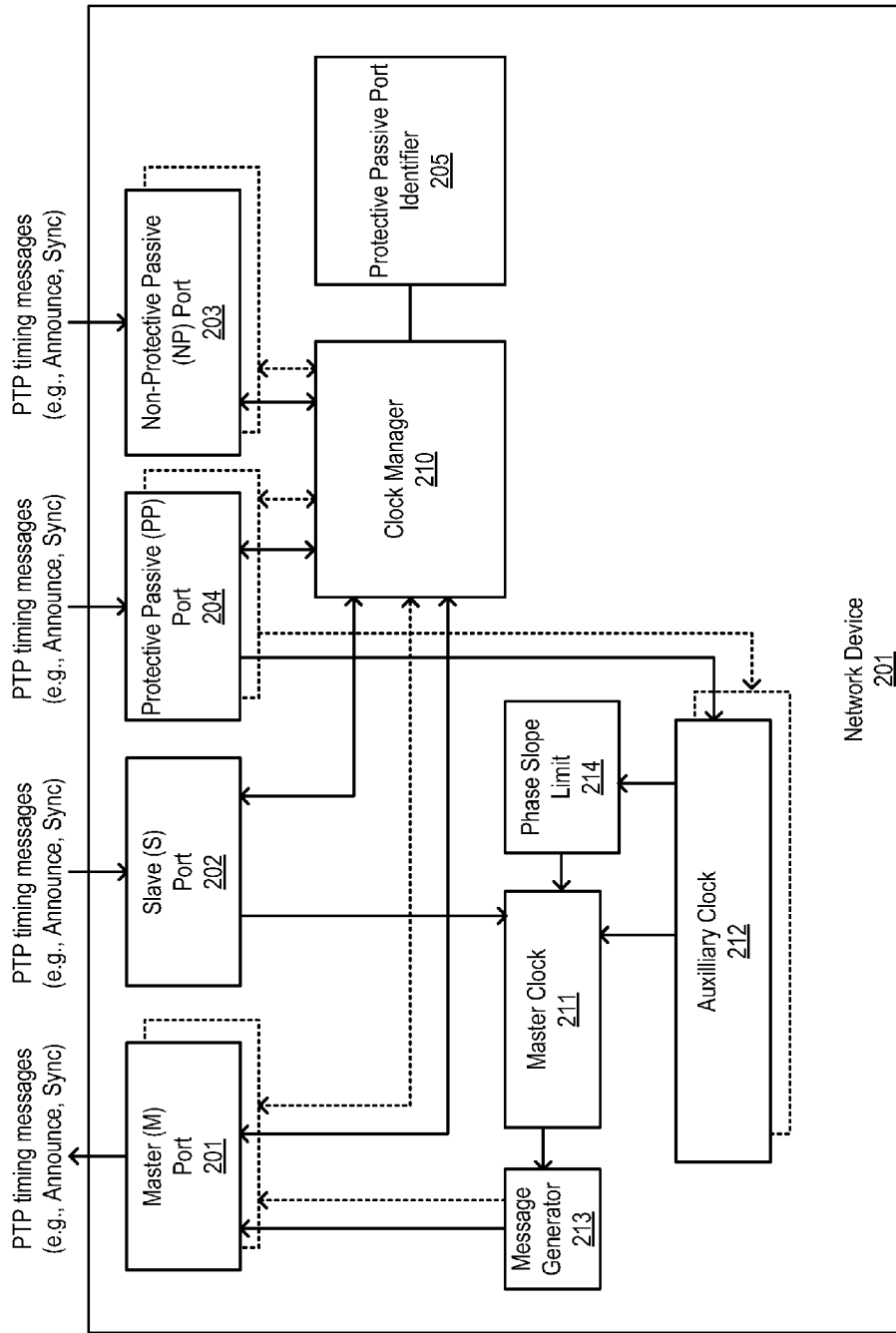

FIG. 2

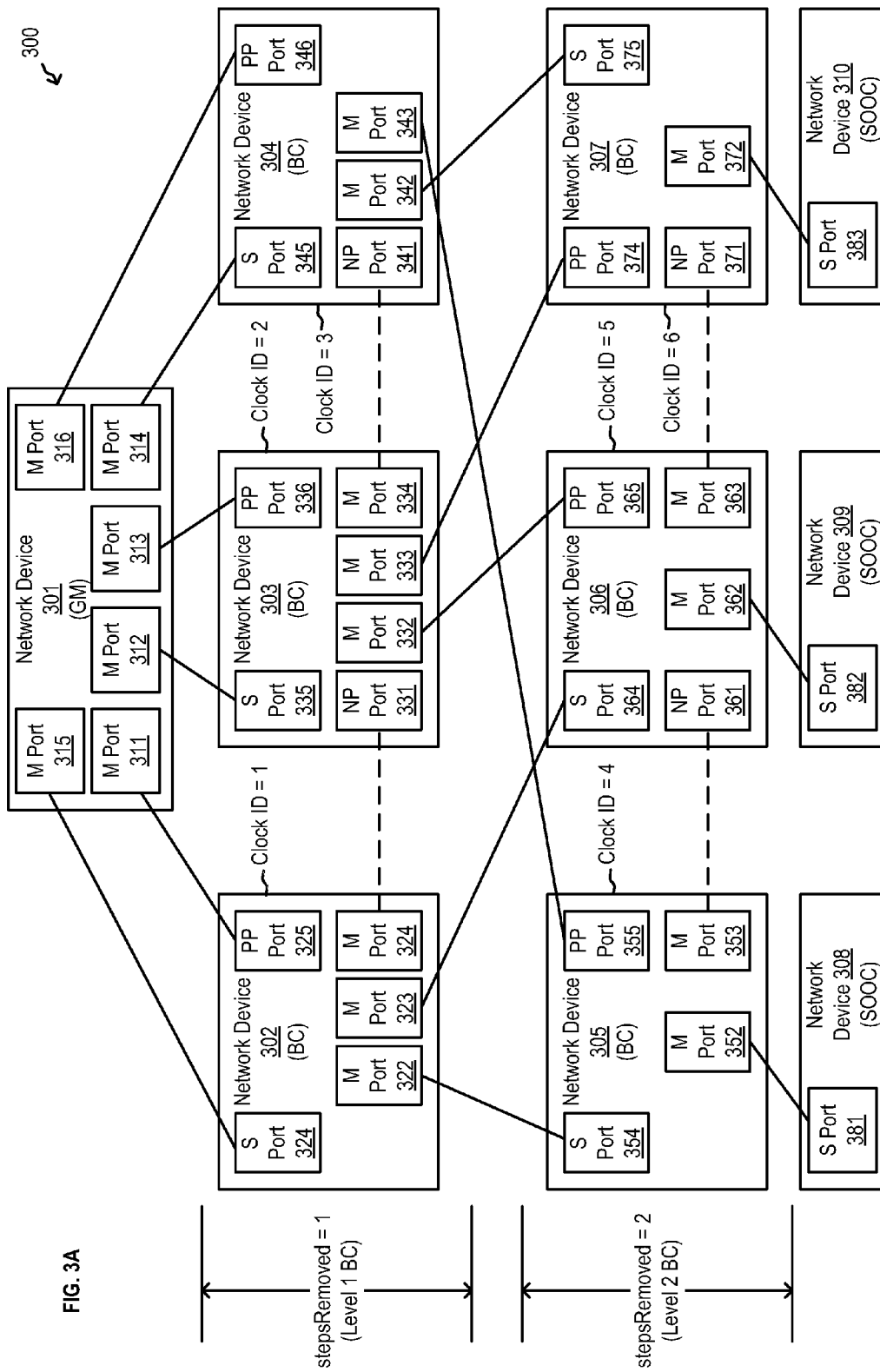
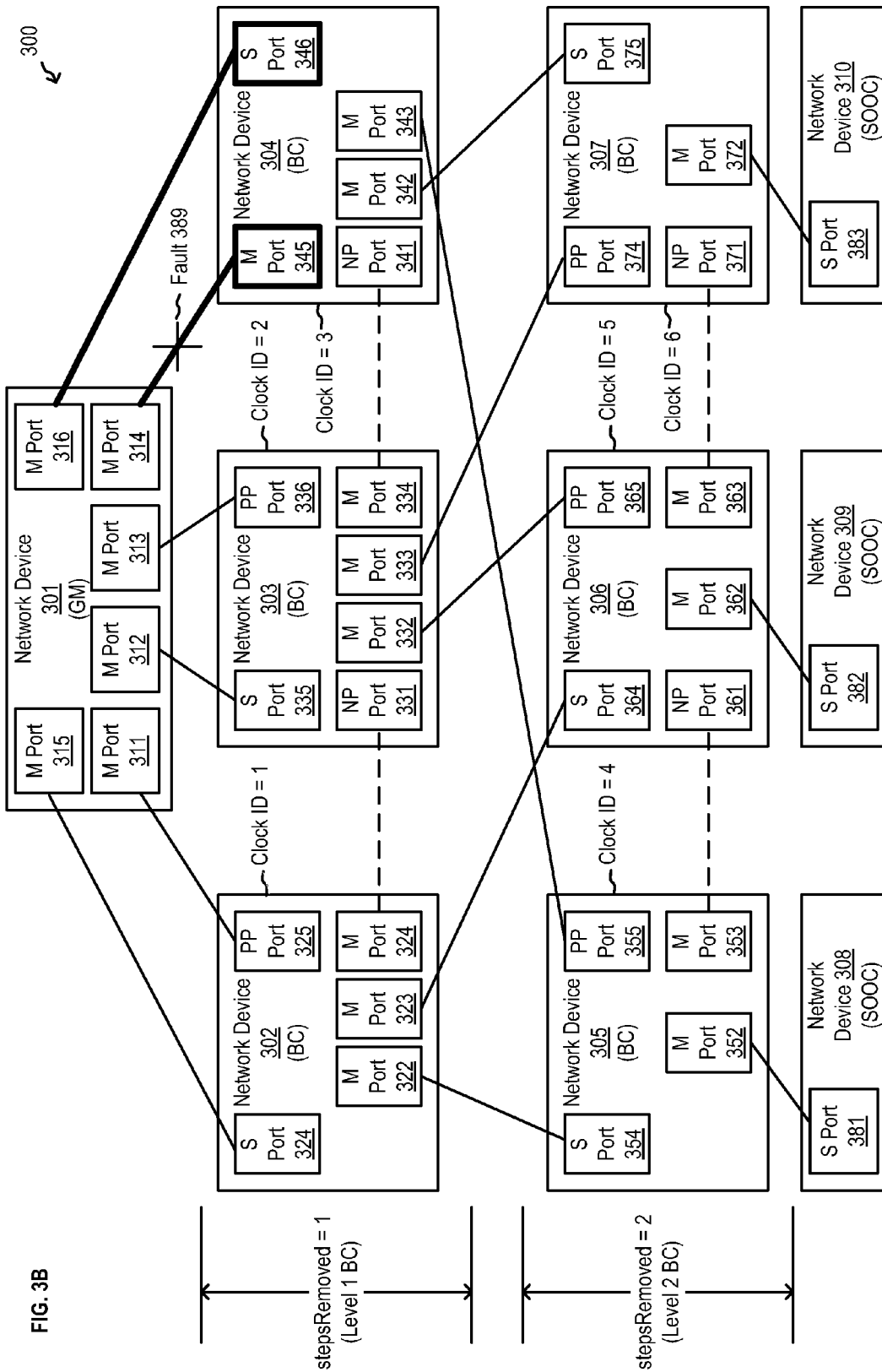

FIG. 3A



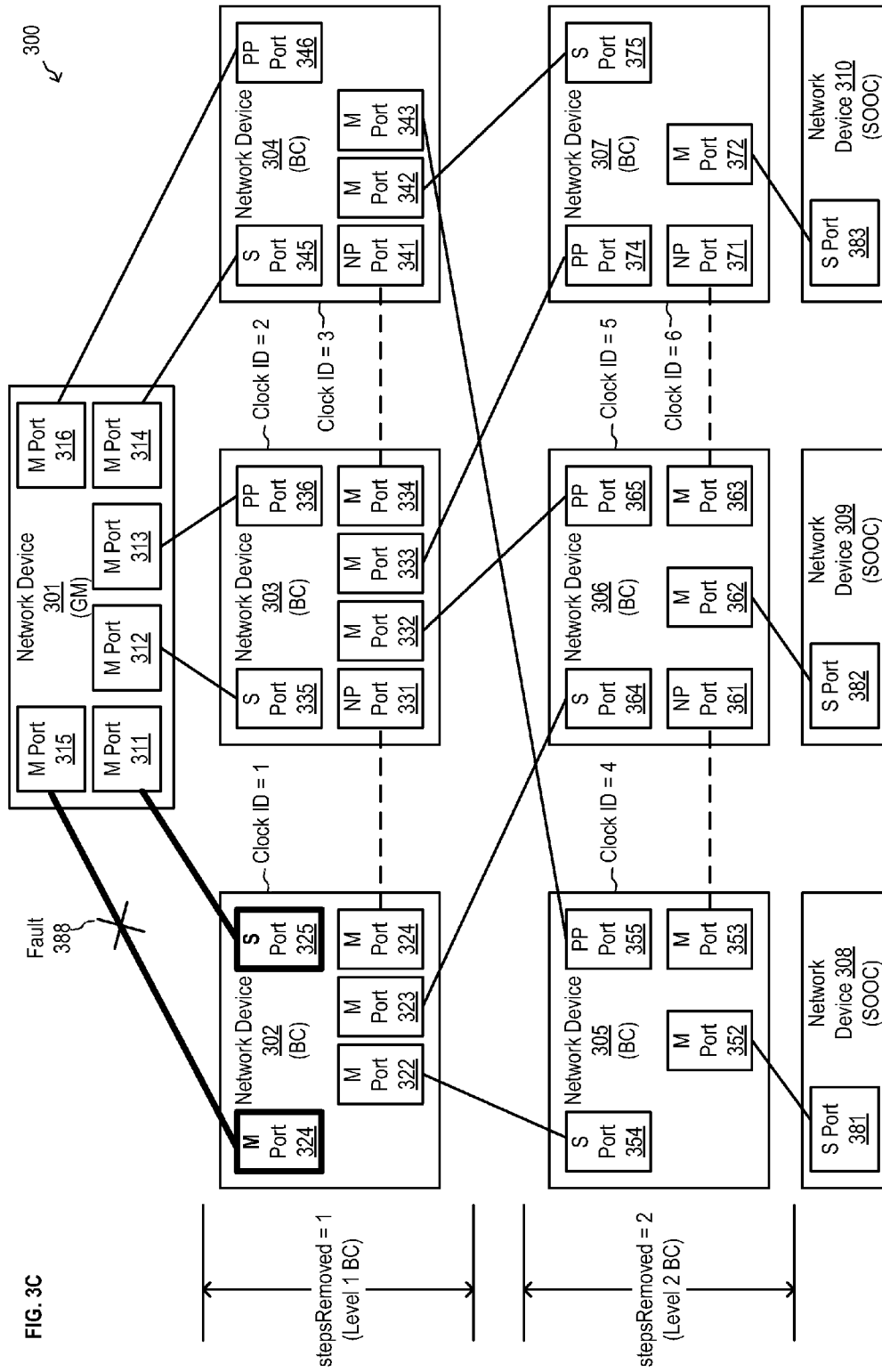
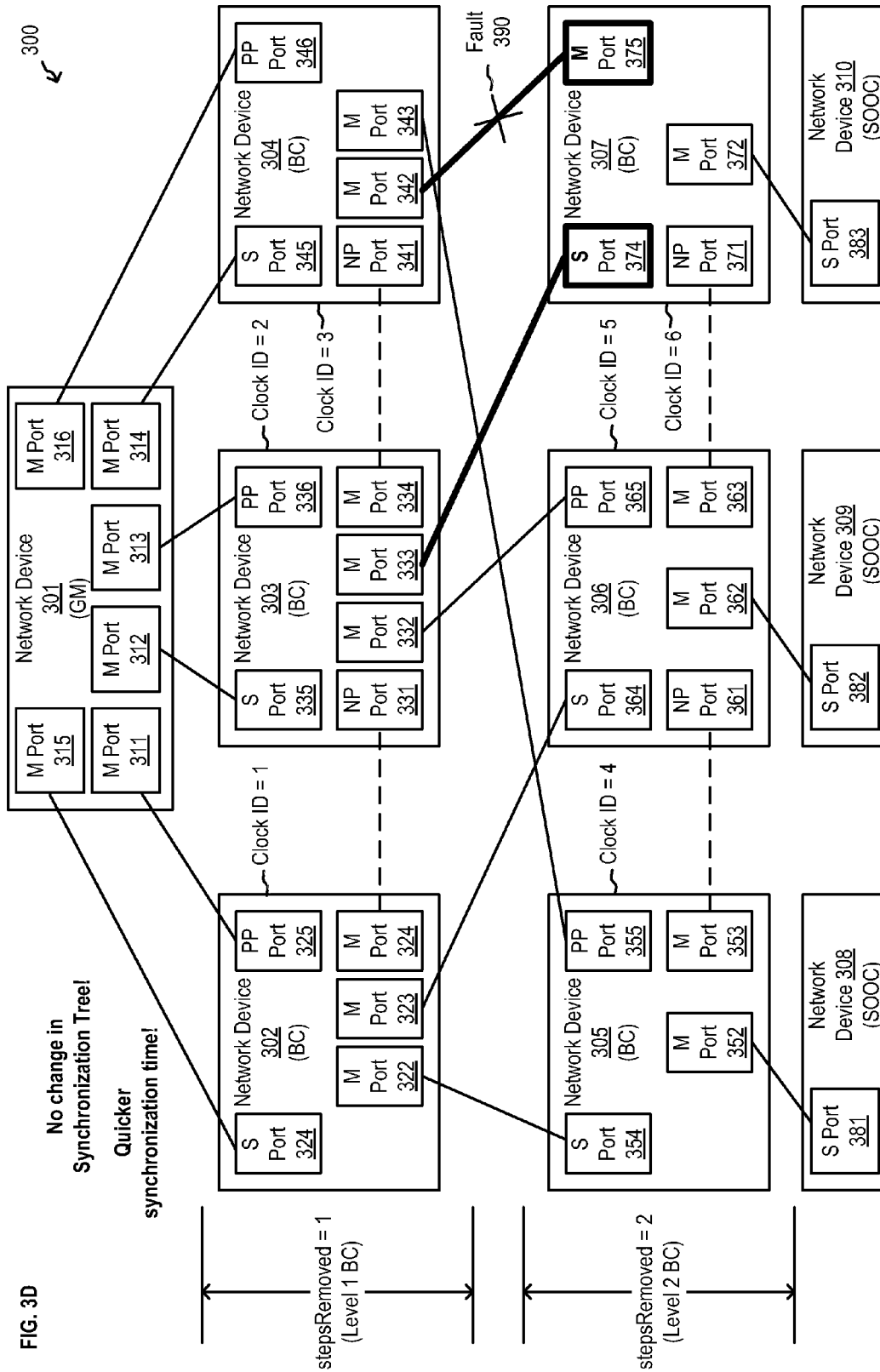

FIG. 3C



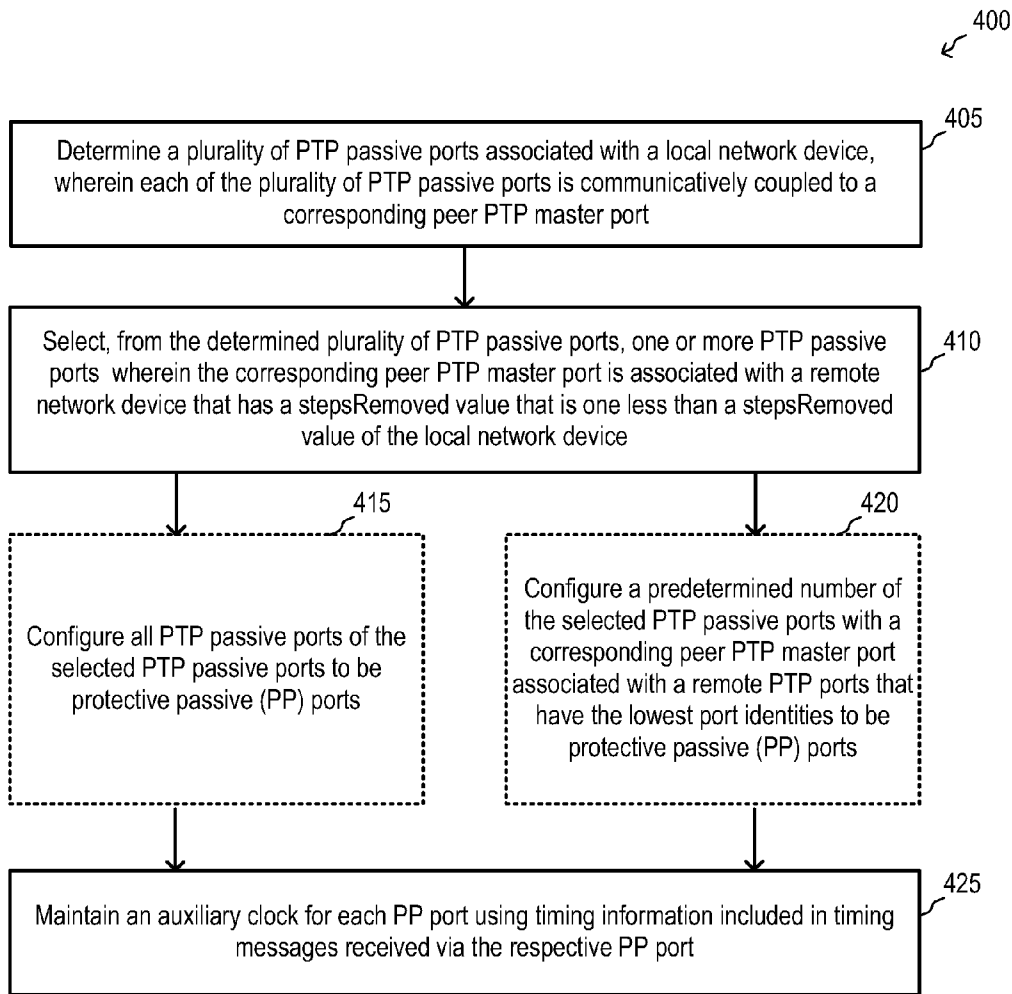

FIG. 4

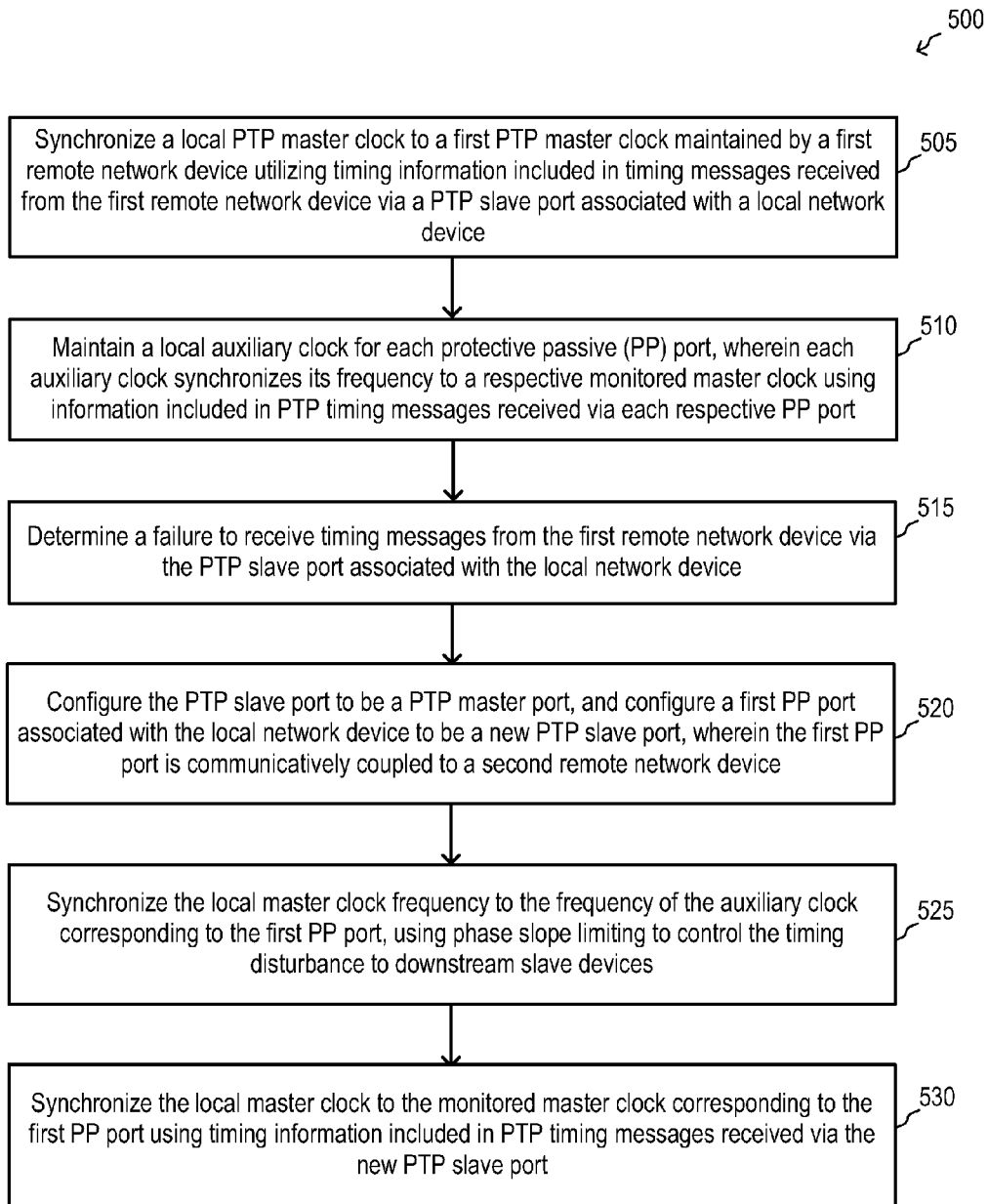

FIG. 5

1

METHOD FOR ROBUST PTP SYNCHRONIZATION WITH DEFAULT 1588V2 PROFILE

FIELD

Embodiments of the invention relate to the field of packet networks; and more specifically, to clock synchronization over a network.

BACKGROUND

The Precision Time Protocol (PTP) is a protocol utilized for synchronizing clocks throughout a network. PTP was originally defined by the Institute of Electrical and Electronics Engineers (IEEE) 1588-2002 standard, entitled "Standard for a Precision Clock Synchronization Protocol for Networked Measurement and Control Systems" (hereby incorporated by reference), and released in 2002. In 2008, a revised standard, IEEE 1588-2008 entitled "IEEE Standard for a Precision Clock Synchronization Protocol for Networked Measurement and Control Systems" (hereby incorporated by reference) was released. This new version, also commonly known as PTP Version 2 (PTPv2), improves accuracy, precision, and robustness. IEEE 1588-2008 was initially utilized primarily by instrumentation and control applications. The telecom industry, however, has since adopted IEEE 1588-2008 as a solution for providing time synchronization for packet network applications such as mobile backhaul. These packet network applications, however, require microsecond or better time distribution over the network and high quality fault tolerance.

IEEE 1588-2008 defines a best master clock algorithm (BMCA), executed at each PTP clock in the PTP domain, for configuring the PTP clocks to be a grandmaster, boundary clock, or slave clock. By utilizing their BMCA to determine their roles in the PTP domain, the PTP clocks converge to form a synchronization tree. While the synchronization tree is being formed, all clocks start locking (i.e., synchronizing) to their masters. Typically, it requires several minutes for each PTP clock to synchronize to its master. After the synchronization tree is formed, if one or more of the PTP clocks or the network experience a fault, all the downstream clocks will rearrange/re-converge to form a new synchronization tree. During this re-convergence period, timing transients will occur as new master and slave ports are selected by the BMCAs. These timing transients result in a period of time where the clock quality advertised to the ultimate slave clocks is inaccurate. These timing transients persist until all PTP clocks in the synchronization tree actually acquire synchronization to their new masters. In other words, for several minutes, or perhaps an hour or longer in larger networks, the timing accuracy is not as good as advertised. This results in the application being provided with inadequate timing accuracy. The timing transients that occur during the re-convergence period are not acceptable by packet network applications in the telecom domain.

Known techniques, such as holdover, exist to work around certain failure/recovery scenarios. Such techniques, however, are inadequate for prolonged outages. Further, because the BMCA will advertise a clock quality that is not true during failure-induced rearrangements, holdover techniques will not work.

SUMMARY

Exemplary methods for reducing sync time in a first network device for supporting Precision Time Protocol (PTP) in

2

a network are herein described. In one embodiment, the methods include receiving, by a first PTP port associated with the first network device configured as a PTP slave port, PTP timing messages from a second PTP port associated with a second network device configured as a PTP master port, wherein the PTP timing messages include timing information of a PTP master clock maintained by the second network device. In one embodiment, the methods further include maintaining a PTP master clock based on the timing information included in the PTP timing messages received from the second network device via the first PTP port. In one embodiment, the methods further include receiving, by a third PTP port associated with the first network device configured as a PTP passive port, PTP timing messages from a fourth PTP port associated with a third network device configured as a PTP master port, wherein the PTP timing messages include timing information of a PTP master clock maintained by the third network device.

According to one embodiment, the methods include determining the third PTP port is a protective passive port based on a stepsRemoved value associated with the third network device, wherein a stepsRemoved value indicates a number of boundary clock levels a respective network device is away from a PTP grandmaster clock of the network. In one embodiment, in response to determining the third PTP port is a protective passive port, maintaining a PTP auxiliary clock based on the timing information included in the PTP timing messages received from the third network device via the third PTP port, wherein in an event that the first network device fails to receive PTP timing messages from the second network device via the first PTP port, the PTP auxiliary clock is utilized by the first network device to synchronize its PTP master clock to the PTP master clock maintained by the third network device.

In one aspect of the invention, determining the third PTP port is a protective passive port comprises determining the third network device has a stepsRemoved value that is one less than a stepsRemoved value of the first network device. In one embodiment, determining the third PTP port is a protective passive port further comprises receiving, by a fifth PTP port associated with the first network device configured as a PTP passive port, PTP timing messages from an sixth PTP port associated with a fourth network device configured as a PTP master port, wherein the PTP timing messages include timing information of a PTP master clock maintained by the fourth network device, and in response to determining the fourth network device has a stepsRemoved value that is equal to a stepsRemoved value of the first network device, determining the fifth PTP port is a non-protective passive port.

In one aspect of the invention, determining the third PTP port is a protective passive port comprises receiving, by a fifth PTP port associated with the first network device configured as a PTP passive port, PTP timing messages from an sixth PTP port associated with a fourth network device configured as a PTP master port, wherein the PTP timing messages include timing information of a PTP master clock maintained by the fourth network device, determining the third network device has a stepsRemoved value that is equal to a stepsRemoved value of the fourth network device, and determining the fourth PTP port associated with the third network device has a port identity (ID) that is less than a port ID of the sixth PTP port associated with the fourth network device.

According to one embodiment, the methods further include in response to determining a failure to receive PTP timing messages from the second network device via the first PTP port, configuring the first PTP port to be a PTP master port, configuring the third PTP port to be a PTP slave port, and

utilizing information of the PTP auxiliary clock to synchronize the PTP master clock maintained by the first network device to the PTP master clock maintained by the third network device. In one embodiment, the methods further include applying a phase slope limit to the PTP master clock maintained by the first network device after the third PTP port has been configured to be a PTP slave port.

In one embodiment, the second network device and the third network device are a same network device configured to serve as a PTP grandmaster clock of the network. In an alternate embodiment, the second network device and the third network device are different network devices, wherein the second network device and the third network device are configured to serve as a PTP boundary clock of the network. In one embodiment, the second network device and the third network device are synchronized to the same grandmaster.

BRIEF DESCRIPTION OF THE DRAWINGS

Embodiments of the invention are illustrated by way of example and not limitation in the figures of the accompanying drawings in which like references indicate similar elements.

FIG. 1A illustrates a conventional PTP network.

FIG. 1B illustrates a conventional PTP network.

FIG. 1C illustrates a conventional PTP network.

FIG. 2 is a block diagram illustrating a network device for supporting PTP according to one embodiment.

FIG. 3A is a block diagram illustrating a PTP network according to one embodiment.

FIG. 3B is a block diagram illustrating a PTP network according to one embodiment.

FIG. 3C is a block diagram illustrating a PTP network according to one embodiment.

FIG. 3D is a block diagram illustrating a PTP network according to one embodiment.

FIG. 4 is a flow diagram illustrating a method for maintaining an auxiliary clock according to one embodiment.

FIG. 5 is a flow diagram illustrating a method for reducing sync time in a PTP network according to one embodiment.

DESCRIPTION OF EMBODIMENTS

In the following description, numerous specific details such as logic implementations, opcodes, means to specify operands, resource partitioning/sharing/duplication implementations, types and interrelationships of system components, and logic partitioning/integration choices are set forth in order to provide a more thorough understanding of the present invention. It will be appreciated, however, by one skilled in the art that the invention may be practiced without such specific details. In other instances, control structures, gate level circuits and full software instruction sequences have not been shown in detail in order not to obscure the invention. Those of ordinary skill in the art, with the included descriptions, will be able to implement appropriate functionality without undue experimentation.

References in the specification to “one embodiment,” “an embodiment,” “an example embodiment,” etc., indicate that the embodiment described may include a particular feature, structure, or characteristic, but every embodiment may not necessarily include the particular feature, structure, or characteristic. Moreover, such phrases are not necessarily referring to the same embodiment. Further, when a particular feature, structure, or characteristic is described in connection with an embodiment, it is submitted that it is within the knowledge of one skilled in the art to affect such feature,

structure, or characteristic in connection with other embodiments whether or not explicitly described.

In the following description and claims, the terms “coupled” and “connected,” along with their derivatives, may be used. It should be understood that these terms are not intended as synonyms for each other. “Coupled” is used to indicate that two or more elements, which may or may not be in direct physical or electrical contact with each other, cooperate or interact with each other. “Connected” is used to indicate the establishment of communication between two or more elements that are coupled with each other.

An electronic device or a computing device (e.g., an end station, a network device) stores and transmits (internally and/or with other electronic devices over a network) code (composed of software instructions) and data using machine-readable media (e.g., machine-readable storage media such as magnetic disks; optical disks; read only memory; flash memory devices; phase change memory) and transitory machine-readable transmission media (e.g., electrical, optical, acoustical or other form of propagated signals—such as carrier waves, infrared signals). In addition, such electronic devices include hardware, such as a set of one or more processors coupled to one or more other components—e.g., one or more non-transitory machine-readable storage media (to store code and/or data) and network connections (to transmit code and/or data using propagating signals), as well as user input/output devices (e.g., a keyboard, a touchscreen, and/or a display) in some cases. The coupling of the set of processors and other components is typically through one or more interconnects within the electronic devices (e.g., busses and possibly bridges). Thus, a non-transitory machine-readable medium of a given electronic device typically stores instructions for execution on one or more processors of that electronic device. One or more parts of an embodiment of the invention may be implemented using different combinations of software, firmware, and/or hardware.

As used herein, a network device (e.g., a router, switch, bridge) is a piece of networking equipment, including hardware and software, which communicatively interconnects other equipment on the network (e.g., other network devices, end stations). Some network devices are “multiple services network devices” that provide support for multiple networking functions (e.g., routing, bridging, switching, Layer 2 aggregation, session border control, Quality of Service, and/or subscriber management), and/or provide support for multiple application services (e.g., data, voice, and video). Subscriber end stations (e.g., servers, workstations, laptops, netbooks, palm tops, mobile phones, smartphones, multimedia phones, Voice Over Internet Protocol (VOIP) phones, user equipment, terminals, portable media players, GPS units, gaming systems, set-top boxes) access content/services provided over the Internet and/or content/services provided on auxiliary private networks (VPNs) overlaid on (e.g., tunneled through) the Internet. The content and/or services are typically provided by one or more end stations (e.g., server end stations) belonging to a service or content provider or end stations participating in a peer-to-peer (P2P) service, and may include, for example, public webpages (e.g., free content, store fronts, search services), private webpages (e.g., username/password accessed webpages providing email services), and/or corporate networks over VPNs. Typically, subscriber end stations are coupled (e.g., through customer premise equipment coupled to an access network (wired or wirelessly)) to edge network devices, which are coupled (e.g.,

through one or more core network devices) to other edge network devices, which are coupled to other end stations (e.g., server end stations).

A network interface may be physical or auxiliary; and an interface address is an IP address assigned to a network interface, be it a physical network interface or auxiliary network interface. A physical network interface is hardware in a network device through which a network connection is made (e.g., wirelessly through a wireless network interface controller (WNIC) or through plugging in a cable to a port connected to a network interface controller (NIC)). Typically, a network device has multiple physical network interfaces. A auxiliary network interface may be associated with a physical network interface, with another auxiliary interface, or stand on its own (e.g., a loopback interface, a point to point protocol interface). A network interface (physical or auxiliary) may be numbered (a network interface with an IP address) or unnumbered (an network interface without an IP address). A loopback interface (and its loopback address) is a specific type of auxiliary network interface (and IP address) of a node (physical or auxiliary) often used for management purposes; where such an IP address is referred to as the nodal loopback address. The IP address(es) assigned to the network interface(s) of a network device, are referred to as IP addresses of that network device; at a more granular level, the IP address(es) assigned to network interface(s) assigned to a node implemented on a network device, can be referred to as IP addresses of that node.

IEEE 1588-2008 defines three types of PTP clocks: Ordinary Clock (OC), Boundary Clock (BC), and Transparent Clock (TC). An OC has one instance of the PTP protocol running (i.e., one PTP port). An OC can either provide timing to the PTP time domain (i.e., be the grandmaster, described in further details below) or can regenerate the timing from a grandmaster (i.e., be the slave, described in further details below). Alternatively, an OC can be configured to be Grandmaster-Only Ordinary Clock (GMOC), which only serves as the grandmaster, or a Slave-Only Ordinary Clock (SOOC), which only serves as a slave. A BC has more than one instance of the PTP protocol running (i.e., multiple PTP ports). A BC receives timing messages from an upstream master, synchronizes its local time of day to these timing messages, and distributes that local time of day to downstream slaves. The upstream masters can be BCs, OCs, GMOCs, or any combination thereof. The downstream slaves can be BCs, OCs, SOOCs, or any combination thereof. Thus, a BC provides intermediate timing regeneration between grandmasters and slave OCs. A BC needs to provide fault tolerance required by the telecom network devices. A TC is also situated between grandmasters and slave OCs/SOOCs, but does not regenerate timing signals.

Each PTP device periodically sends Announce messages via the master PTP ports to other PTP devices in the same PTP domain. Here, a PTP device refers to a network device that supports PTP. The Announce messages include clock information and identity of the sending PTP device's PTP clock, stepsRemoved value of the sending PTP device, and information concerning the grandmaster. A best master clock algorithm (BMCA) executed at each PTP clock utilizes information included in the received Announce messages to determine the role of the local master clock in the PTP domain. IEEE 1588-2008 defines three roles: grandmaster (GM), boundary clock (BC), and slave.

A GM provides the ultimate time source to all other PTP clocks in a PTP time domain. The GM derives its timing from a non-PTP source, and distributes this time into the PTP domain using PTP messages (e.g., PTP Sync messages) on

the packet network. All PTP clocks (other than the GM) synchronize to one GM clock in a PTP time domain. As a result of the BMCA running on every clock, an OC, GMOC, or BC can take on the role as the GM.

A slave ordinary clock utilizes time codes included in PTP messages received from a grandmaster or a boundary clock to generate a local time that is an estimate of its domain's grandmaster time. This regenerated time is then provided to one or more non-PTP application that is running on the slave ordinary clock or attached to the slave ordinary clock via a non-PTP interface. Note that either an OC or SOOC can be a slave ordinary clock. A boundary clock (BC) utilizes time codes included in PTP messages received from an upstream master clock to regenerate the time codes and send them to downstream slaves. PTP clocks only synchronize to masters of the same PTP domain, which is identified by a PTP domain number.

IEEE 1588-2008 specifies that a PTP port can be configured to be in one of three states: master, slave, or passive. It shall be understood that PTP ports can be in one or more other states, including, for example, uncalibrated, listening, disabled, faulty, initialing state, etc. At any given moment, there is a maximum of only one PTP port in a PTP clock that can be configured to be in the slave state. Throughout the description, a PTP port configured to be in the master, slave, or passive state will simply be referred to as a PTP master port, PTP slave port, or PTP passive port, respectively. A PTP clock synchronizes its local master clock to the time codes received on a PTP slave port from a peer PTP master port. A PTP passive port is utilized for pruning the PTP network to avoid timing loops. Here, a "timing loop" refers to a phenomenon where a PTP clock is attempting to synchronize to itself by using timing codes that it originated.

PTP port configuration will now be described. When a PTP port receives an Announce message that indicates the sender has a worse clock as compared to the local master clock and all other master clocks seen by the local clock in the network according to the timing information in the Announce messages received on any local PTP port, the receiving port will be configured to be in the master state, and the peer PTP port will be configured to be in the slave state. When a PTP port receives an Announce message that indicates the sender has a clock which has similar quality as compared to the local master clock and all other master clocks seen by the local clock in the network according to the timing information in the Announce messages received on any local PTP port (e.g., they are syncing to the same grandmaster), then the receiving port can be configured to be either in the master or passive state, depending on stepsRemoved values and portIdentity of the receiving and transmitting PTP port. Here, "stepsRemoved" refers to the number of BC hops away the respective PTP clock is from the GM, and "portIdentity" is a unique value/identifier that is assigned to each PTP port in the PTP domain. A portIdentity uniquely identifies a PTP port, and comprises the clockIdentity and a portNumber. A clockIdentity uniquely identifies the PTP clock, and the portNumber is unique within that PTP clock. Note that PTP ports on a clock A will have lower portIdentities than PTP ports on a clock B if clock A has a clockIdentity that is lower than clock B.

The configuration of a PTP port (to be a PTP master or passive port) when the transmitting and receiving PTP clocks have similar quality will now be discussed. The receiving port will be configured to be a PTP master port (and the peer PTP port will be configured as a PTP passive port) if the receiving PTP clock's stepsRemoved value is lower than the sender. The receiving port will also be configured to be a PTP master port (and the peer PTP port will be configured as a PTP

passive port) if the receiving PTP clock's stepsRemoved value is the same as the sender, but the receiving PTP port's portIdentity is lower than the sender's portIdentity. If, however, the receiving PTP clock's stepsRemoved value is the same as the sender, but the receiving PTP port's portIdentity is larger than the sender's portIdentity, then the receiving port will be configured to be a PTP passive port (and the peer PTP port will be configured as a PTP master port). Finally, if the receiving PTP clock has a stepsRemoved value that is larger than the stepsRemoved value of the sender (i.e., the receiving clock is "farther" from the GM as compared to the transmitting clock), then the receiving port will be configured to be a PTP passive port (and the peer PTP port will be configured as a PTP master port).

When all the PTP clocks in the network have settled/converged, the resulting links between the master, slave, and passive ports of the PTP clocks form a synchronization tree. Any change in a clock's quality, a clock failure, or a network failure will cause all downstream clocks to reacquire synchronization to a new master (i.e., form a new synchronization tree). While the PTP clocks re-converge to form the new synchronization tree, the accuracy of the PTP clocks involved in the re-convergence process will be impaired, which affects the accuracy of the time provided to the applications utilizing the clocks. Limitations of conventional PTP networks will now be described by way of illustration through the figures below, in which like references indicate similar elements.

FIGS. 1A-1C are block diagrams illustrating conventional PTP network 100. Throughout the figures, various PTP master ports, PTP slave ports, and PTP passive ports will simply be referred to as M ports, S ports, and P ports, respectively. Referring first to FIG. 1A, which is a block diagram illustrating conventional PTP network 100 that includes network devices 101-110 communicatively coupled to each other as shown. In this illustrated configuration, network device 101 has been configured to be the GM (herein referred to as GM 101), network devices 102-107 have been configured to be BCs (herein referred to as BCs 102-107, respectively), and network devices 108-110 have been configured to be SOOCs (herein referred to as SOOCs 108-110, respectively). BCs 102-107 have been assigned clockIdentities 1-6, respectively. Thus, the portIdentities of BC 102 are the lowest and the portIdentities of BC 107 are the highest. In this example, network 100 includes 2 BC levels. BCs 102-104 belong to the first BC level (i.e., they are 1 BC level/hop away from GM 101), and thus, each has a stepsRemoved value of 1. BCs 105-107 belong to the second BC level (i.e., they are 2 BC levels/hops away from GM 101), and thus, each has a stepsRemoved value of 2.

GM 101 includes M port 115 communicatively coupled to S port 124 of BC 102, M port 112 communicatively coupled to S port 135 of BC 103, M ports 114 and 116 communicatively coupled to S port 145 and P port 146, respectively, of BC 104. BC 102 includes S port 124 as described above. BC 102 further includes M port 122 communicatively coupled to S port 154 of BC 105, and M port 123 communicatively coupled to S port 164 of BC 106. BC 103 includes S port 135 as described above. BC 103 further includes M port 133 communicatively coupled to P port 174 of BC 107, and M port 134 communicatively coupled to P port 141 of BC 104.

BC 104 includes S port 145, P port 146, and P port 141 as described above. BC 104 further includes M port 142 communicatively coupled to P port 165 of BC 106, and M port 143 communicatively coupled to S port 175 of BC 107. BC 105 includes S port 154 as described above. BC 105 further includes M port 152 communicatively coupled to S port 181 of SOOC 108, and M port 153 communicatively coupled to P

port 161 of BC 106. BC 106 includes S port 164, P port 165, and P port 161 as described above. BC 106 further includes M port 162 communicatively coupled to S port 182 of SOOC 109. BC 107 includes P port 174 and S port 175 as described above. BC 107 further includes M port 172 communicatively coupled to S port 183 of SOOC 110. SOOCs 108-110 include S ports 181-183, respectively, as described above.

Referring now to FIG. 1B, which is a block diagram illustrating conventional PTP network 100. Network 100 illustrated in FIG. 1B is similar to network 100 shown in FIG. 1A, except that fault 189 has occurred. In FIG. 1B, the PTP ports and links in bold are those which are affected by fault 189. Due to fault 189, BC 104 is no longer able to receive PTP messages from GM 101 via S port 145, which prevents BC 104 from syncing its local master clock to GM 101 via S port 145. As a result, BC 104 must select a new PTP port to be a slave port. In this example, BC 104 reconfigures its PTP port 146 from passive to slave state, and PTP port 145 from slave to master state (because only one PTP port can be a slave at a PTP clock). Thus, BC 104 has selected PTP port 146 to be its new slave port.

The synchronization tree shown in FIG. 1B remains unchanged after fault 189 has occurred. A change in slave port, however, has occurred. When a conventional PTP clock selects a new slave port, it requires time to sync its local master clock to the new master clock through the new slave port. While this syncing process is occurring, all downstream PTP devices that rely on the PTP clock will also be affected. In this example, BC 107 and SOOC 110 will be affected. Embodiments of the present invention overcome these limitations by reducing the impact, e.g., by reducing the sync time, described in further details below.

Referring now to FIG. 1C, which is a block diagram illustrating conventional PTP network 100. Network 100 illustrated in FIG. 1C is similar to network 100 shown in FIG. 1A, except that fault 188 has occurred. In FIG. 1C, the PTP ports and links in bold are those which are affected by fault 188. Due to fault 188, BC 102 is no longer able to receive PTP messages from GM 101 via S port 124, which prevents BC 102 from syncing its local master clock to GM 101 via S port 124. As a result, BC 102 must select a new PTP port to be a slave port. In this example, BC 102 reconfigures its PTP port 123 from master to slave state, and PTP port 124 from slave to master state (because only one PTP port can be a slave at a PTP clock). Thus, BC 102 has selected PTP port 123 to be its new slave port. In response to BC 102 configuring PTP port 123 to be a new slave port, BC 106 reconfigures its PTP port 164 from slave state to master state. Further, BC 106 has selected its PTP port 165 to be the new slave port. In order to avoid a timing loop, BC 106 has also reconfigured its PTP port 161 to be a master port. The reconfiguration of PTP port 161 to be a master port, in turn, causes BC 105 to reconfigure its PTP port 153 to be a slave port. Given that only one PTP port can be a slave port at a PTP clock, BC 105 reconfigures its PTP port 154 from slave to master port. The reconfiguration of PTP port 154 to be a master port, in turn, causes BC 102 to reconfigure its PTP port 122 from master state to passive state.

The new synchronization tree shown in FIG. 1C has resulted in BC 102 changing its stepsRemoved value from 1 to 3. In other words, BC 102 is now 3 BC levels away from GM 101. When a synchronization tree is rearranged, all downstream PTP devices will be affected. The time it takes for a synchronization tree to rearrange can be quite long, depending on the network size. Embodiments of the present

invention overcome these limitations by reducing the impact, e.g., by reducing the sync time, described in further details below.

FIG. 2 is a block diagram illustrating network device **201** for supporting PTP according to one embodiment. Network device **201** includes one or more PTP ports, for example PTP ports **201-204**. It shall be understood that more or less PTP ports can be included as part of network device **201**. PTP ports **201-204** are responsible for forwarding received information concerning master clock quality and stepsRemoved values of other PTP master clocks in the network to clock manager **210**. Such information is included, for example, in received PTP Announce and/or Sync messages.

Clock manager **210** determines the state (e.g., master, slave, passive) of PTP ports **201-204** based on the received master clock quality and stepsRemoved values. Clock manager **210** may determine the states of PTP ports **201-204** using mechanisms similar to those described above. Other mechanisms for determining the state of each PTP port can be used without departing from the broader scope and spirit of the present invention. In the illustrated example, clock manager **210** has configured PTP port **201** to be a PTP master port (herein referred to as an M port), PTP port **202** to be a PTP slave port (herein referred to as an S port), and PTP ports **203-204** as passive ports (herein referred to as P ports). It shall be understood that clock manager **210** can configure the PTP ports such that there are multiple instances of M ports **201**, and/or P ports **203-204**.

Clock manager **210** utilizes time codes received via S port **202** to maintain (i.e., sync) master clock **211** to the master clock of the PTP device which is communicatively coupled to S port **202**. Throughout the description, the remote PTP clock which is communicatively coupled to the S port shall be referred to as the “main remote master clock”. The use of time codes in PTP timing messages (e.g., PTP Sync messages) to sync a local master clock to a main remote master clock is well known in the art. For the sake of brevity, it will not be discussed here. Network device **201** further includes message generator **213** for generating and sending PTP timing messages (e.g., Announce, Sync, etc.) via M port **201**. PTP timing messages are generated based on at least information of master clock **211** and the stepsRemoved value of network device **201**. Generation and sending of PTP timing messages, such as, for example, Announce and Sync messages, are well known in the art, and will not be described here.

A conventional PTP device may include a passive port. PTP time codes received via a conventional passive port, however, are not processed. As a result, a conventional PTP device is not able to leverage off time codes received via a passive port to reduce the time it takes to sync the local master clock to a new master clock when the passive port is reconfigured to be a slave port. For example, in FIG. 1B, when BC **104** switches from syncing its local master clock via PTP port **145** to PTP port **146**, BC **104** is not able to reduce its sync time by leveraging off time codes received via PTP port **146** while PTP port **146** was in the passive state. Embodiments of the present invention overcome these limitations by processing time codes received from at least one PTP passive port.

In one embodiment, network device **201** includes protective passive (PP) port identifier **205** for identifying one or more passive ports as “protective passive” ports (herein referred to as PP ports) and one or more other passive ports (if any) as “non-protective passive” ports (herein referred to as NP ports). By identifying passive ports as “protective passive” ports, network device **201** is able to maintain one or more local auxiliary clocks using timing information received via the PP ports. The one or more auxiliary clocks can then be

utilized by network device **201** to reduce the amount of time required to sync to a new master clock, described in further details below.

In one embodiment, PP port identifier **205** identifies one or more PP ports by determining a plurality of local PTP ports that have been configured as passive ports. In one embodiment, PP port identifier **205** selects, from the identified plurality of passive ports, a first group of passive ports that are communicatively coupled to PTP devices with a stepsRemoved value that is 1 less than the stepsRemoved value of network device **201**. In one embodiment, PP port identifier **205** configures each of the selected passive ports as a PP port. In an alternate embodiment, PP port identifier **205** configures a predetermined number of the selected first group of passive ports that are communicatively coupled to remote PTP ports with the lowest portIdentities (among all PTP devices communicatively coupled to the selected first group of passive ports) as PP ports. In one embodiment, the predetermined number of passive ports to be configured as PP ports represents percentage. For example, if there are 10 passive ports in the selected first group of passive ports, PP port identifier **205** may be configured to identify 30% (i.e., 3 out of 10) passive ports associated with remote PTP ports with the lowest portIdentities (among all PTP ports associated with the first group of passive ports) as PP ports. Alternatively, the predetermined number of passive ports to be configured as PP ports represents a raw number. For example, if there are 10 passive ports in the selected first group of passive ports, PP port identifier **205** may be configured to identify a predetermined number of 2 passive ports associated with remote PTP ports with the lowest portIdentities (among all PTP ports associated with the first group of passive ports) as PP ports.

In one embodiment, if PP port identifier **205** determines that none of the passive ports are communicatively coupled to a PTP device that has a stepsRemoved value that is 1 less than the stepsRemoved value of network device **201**, then PP port identifier **205** identifies a predetermined number (either as a percentage or raw number, as described above) of passive ports that are communicatively coupled to the PTP ports with the lowest portIdentity as the PP ports. FIG. 2 illustrates by way of example, and not limitation, passive port **203** has been identified as a NP port, and passive port **204** has been identified as a PP port. It shall be understood that PP port identifier **205** can configure the PTP passive ports such that there are multiple instances of NP ports and/or PP ports. In other words, there can be multiple NP ports and/or PP ports at network device **201**.

In one embodiment, after one or more PP ports have been identified, contrary to a conventional PTP device, time codes received (e.g., as part of PTP Sync messages) via the identified PP ports are processed to sync one or more local auxiliary clocks to master clocks maintained by remote PTP devices that are communicatively coupled to the identified PP ports. Throughout the description, the master clock which is communicatively coupled to a PP port of local PTP device is referred to as the “monitored remote master clock”. For example, the master clock which is communicatively coupled to PP port **204** shall be referred to as a monitored remote master clock of network device **201**.

In one embodiment, clock manager **210** maintains an auxiliary clock for each identified PP port. Clock manager **210** can approximate the clock frequency of each monitored remote master clock based on the time codes received via a respective PP port. The approximated clock frequency of each monitored remote master clock can then be used to sync a respective auxiliary clock to the respective monitored remote master clock. In the illustrated example, clock man-

ager **210** utilizes time codes received via PP port **204** to maintain auxiliary clock **212**. Clock manager **210** approximates the clock frequency of the monitored remote master clock based on the time codes received via PP port **204**. The approximated clock frequency of the monitored remote master clock can then be used to sync auxiliary clock **212** to the monitored remote master clock.

In an event that network device **201** fails to receive PTP timing messages via its S port **202** (e.g., due to a failure of S port **202**, a failure of the peer master port that is communicatively coupled to S port **202**, or a failure of a network link), network device **201** can configure its S port **202** to be a master port. Further, clock manager **210** identifies one of the local PP ports to be a new slave port. Clock manager **210** then causes master clock **211** to start syncing to the auxiliary clock corresponding to the PP port that has been re-configured to be the new slave port. For example, in response to determining a failure to receive PTP timing messages via S port **202**, clock manager **210** reconfigures PP port **204** to be a new slave port, and starts syncing master clock **211** to auxiliary clock **212**.

In one embodiment, when clock manager **210** starts syncing master clock **211** to an auxiliary clock, clock manager **210** applies phase slope limit **214** (also commonly known as a “phase rate change limit”) in order to prevent the clock phase of master clock **211** from changing more than the value indicated by phase slope limit **214**. Continuing on with the above example, clock manager **210** applies phase slope limit **214** when clock manager **210** starts syncing master clock **211** to auxiliary clock **212**. By limiting the phase change, clock manager **210** prevents timing disturbance to downstream PTP slave devices. In one embodiment, phase slope limit **214** can be configured by a user (e.g., an operator) via an application programming interface (API).

In one embodiment, once the new slave port starts receiving PTP timing messages from the new main remote master clock (former monitored remote master clock), clock manager **210** starts syncing master clock **211** to the new main remote master clock. By syncing to an auxiliary clock (e.g., auxiliary clock **212**), clock manager **210** is able to reduce the amount of time required to sync master clock **211** to the new main remote master clock. Thus, contrary to a conventional PTP device, network device **201** processes time codes received via at least one passive port in order to maintain at least one auxiliary clock, which is utilized to reduce the amount of time required to sync master clock **211** to a new main remote master clock.

When a conventional PTP device selects a new slave port, there is a possibility that the new slave port will result in a new synchronization tree. For example, as illustrated in FIG. 1C, when fault **188** occurs and BC **302** selects PTP port **123** as the new slave port, there is a re-convergence of the synchronization tree, resulting in BC **102** changing from being 1 BC level away from GM **101** to being 3 BC levels away from GM **101**. The re-convergence requires a long duration of time for the new synchronization tree to be pruned. Embodiments of the present invention overcome these limitations by selecting one or more passive ports that are communicatively coupled to remote PTP devices that have a stepsRemoved value that is one less than the stepsRemoved value of the local network device. In this way, when the local network device switches to syncing to the PP port, the hierarchy of the synchronization tree remains unaffected, thereby reducing the amount of time required for all downstream slave clocks to re-sync.

FIGS. 3A-3D are block diagrams illustrating PTP network **300** according to one embodiment. Throughout the figures, various PTP master ports, PTP slave ports, non-protective passive ports, and protective passive ports will simply be

referred to as M ports, S ports, NP ports, and PP ports, respectively. Referring first to FIG. 3A, which is a block diagram illustrating network **100** that includes, but not limited to, network devices **301-310** communicatively coupled to each other as shown. One or more of network devices **301-310** can be implemented as part of network device **201**. In this illustrated configuration, network device **301** has been configured to be the GM (herein referred to as GM **301**), network devices **302-307** have been configured to be BCs (herein referred to as BCs **302-307**, respectively), and network devices **308-310** have been configured to be SOOCs (herein referred to as SOOCs **308-310**, respectively). BCs **302-307** have been assigned clock identities **1-6**, respectively. Thus, the port identities of BC **302** are the lowest and the port identities of BC **307** are the highest. In this example, network **300** includes 2 BC levels. BCs **302-304** belong to the first BC level (i.e., they are 1 BC level/hop away from GM **301**), and thus, each has a stepsRemoved value of 1. BCs **305-307** belong to the second BC level (i.e., they are 2 BC levels/hops away from GM **301**), and thus, each has a stepsRemoved value of 2.

GM **301** includes M ports **315** and **311** communicatively coupled to S port **324** and PP port **325**, respectively, of BC **302**, M ports **312** and **313** communicatively coupled to S port **335** and PP port **336**, respectively, of BC **303**, and M ports **314** and **316** communicatively coupled to S port **345** and PP port **346**, respectively, of BC **304**. BC **302** includes S port **324** and PP port **325** as described above. BC **302** further includes M port **322** communicatively coupled to S port **354** of BC **305**, M port **323** communicatively coupled to S port **364** of BC **306**, and M port **324** communicatively coupled to NP port **331** of BC **303**.

BC **303** includes S port **335**, PP port **336**, and NP port **331** as described above. BC **303** further includes M port **332** communicatively coupled to PP port **365** of BC **306**, M port **333** communicatively coupled to PP port **374** of BC **307**, and M port **334** communicatively coupled to NP port **341** of BC **304**. BC **304** includes S port **345**, PP port **346**, and NP port **341** as described above. BC **304** further includes M port **342** communicatively coupled to S port **375** of BC **307**, and M port **343** communicatively coupled to PP port **355** of BC **305**.

BC **305** includes S port **354** and PP port **355** as described above. BC **305** further includes M port **352** communicatively coupled to S port **381** of SOOC **308**, and M port **353** communicatively coupled to NP port **361** of BC **306**. BC **306** includes S port **364**, PP port **365**, and NP port **361** as described above. BC **306** further includes M port **362** communicatively coupled to S port **382** of SOOC **309**, and M port **363** communicatively coupled to NP port **371** of BC **307**. BC **307** includes PP port **374**, S port **375**, and NP port **371** as described above. BC **307** further includes M port **372** communicatively coupled to S port **383** of SOOC **310**. SOOCs **308-310** include S ports **381-383**, respectively, as described above.

The configuration of network **300** is shown in FIG. 3A for illustrative purposes and not intended to be limitations of the present invention. Embodiments of the present invention apply equally to other network configurations having more or less network devices, arranged in more or less BC levels, and having more or less PTP ports configured to be in different states.

As described above, S port **345** of BC **304** is communicatively coupled to M port **314** of GM **301**. Thus, from the perspective of BC **304**, GM **301** is the main remote master clock. BC **304** includes two PTP passive ports (i.e., PTP ports **341** and **346**). BC **304** has identified (e.g., by utilizing a PP port identifier similar to PP port identifier **205**) PTP passive port **346** as a PP port, and PTP passive port **341** as a NP

passive port because PTP passive port **346** is communicatively coupled to a PTP device which has a stepsRemoved value of one less than the stepsRemoved value of **BC 304**. Here, **GM 301** has a stepsRemoved value of 0 and **BC 304** has a stepsRemoved value of 1. Thus, from the perspective of **BC 304**, **GM 301** is also the monitored remote master clock. As such, the clock manager (similar to clock manager **210**) of **BC 304** utilizes time codes received in PTP timing messages (e.g., Sync messages) from **GM 301** via PP port **346** to sync an auxiliary clock (similar to auxiliary clock **212**) to the monitored remote master clock.

Referring now to FIG. 3B, which is a block diagram illustrating network **300** according to one embodiment. Network **300** illustrated in FIG. 3B is similar to network **300** shown in FIG. 3A, except that fault **389** has occurred. In FIG. 3B, the PTP ports and links in bold are those which are affected by fault **389**. Due to fault **389**, **BC 304** is no longer able to receive PTP messages from its main remote master clock (i.e., **GM 301**) via S port **345**. The failure to receive time codes prevents **BC 304** from syncing its local master clock (similar to master clock **211**) to **GM 301** via S port **345**. As a result, **BC 304** must select a new PTP port to be a slave port.

When a conventional PTP device switches to a new slave port (as illustrated in FIG. 1B), the conventional PTP device requires a long time to sync the local master clock to the new main remote master, and as a result all downstream PTP devices are affected. Embodiments of **BC 304** overcome these limitations by processing time codes received via PTP port **346** while it was in the PP state to sync an auxiliary clock (similar to auxiliary clock **212**) to the monitored remote master clock (i.e., the master clock maintained by **GM 301**). In one embodiment, in response to determining a failure to receive time codes from the main remote master clock via S port **345** (e.g., due to fault **389**), **BC 304** reconfigures PTP port **345** from slave state to master state. **BC 304** starts syncing its local master clock (similar to master clock **211**) to the auxiliary clock (similar to auxiliary clock **212**) corresponding to PP port **346**. Further, **BC 304** reconfigures PTP port **346** from PP state to slave state. Thus, **BC 304** has selected PTP port **346** to be its new slave port. Here, although **GM 301** remains the main remote master clock, the time codes which **BC 304** now syncs its local master clock to are those received via the new slave port **346**.

The amount of time **BC 304** requires to sync its local master clock to the new main remote master clock is less than the amount of time that a conventional PTP device would require because **BC 304** is able to sync its local master clock to the auxiliary clock prior to syncing the local master clock to the new main remote master clock. In one embodiment, **BC 304** also applies a phase slope limit (similar to phase slope limit **214**) to the local master clock when the local master clock starts syncing to the auxiliary clock. In this way, the phase change in the local master clock can be controlled such that it would not disturb the timing of the downstream PTP devices (in this example, **BC 305**, **SOOC 308**, **BC 307**, and **SOOC 310**). Thus, by using mechanisms of the present invention, **BC 304** is able to handle fault **389** such that it is transparent to all downstream PTP devices by using time codes received via PTP port **346** while it was in the PP state to sync the auxiliary clock to the monitored remote master clock.

Although fault **389** has been described as the cause for **BC 304** failing to receive time codes via S port **345**, one having ordinary skill in the art would recognize that the present invention is not limited to any particular type of fault. Embodiments of the present invention apply equally to any failure that prevents **BC 304** from receiving time codes via S port **345**.

Referring now back to FIG. 3A for a moment. As described above, S port **324** of **BC 302** is communicatively coupled to M port **315** of **GM 301**. Thus, from the perspective of **BC 302**, **GM 301** is the main remote master clock. **BC 302** includes one PTP passive port (i.e., PTP port **325**). **BC 302** has identified (e.g., by utilizing a PP port identifier similar to PP port identifier **205**) PTP passive port **325** as a PP port because PTP passive port **325** is communicatively coupled to a PTP device which has a stepsRemoved value of one less than the stepsRemoved value of **BC 302**. Here, **GM 301** has a stepsRemoved value of 0 and **BC 302** has a stepsRemoved value of 1. Thus, from the perspective of **BC 302**, **GM 301** is also the monitored remote master clock. As such, the clock manager (similar to clock manager **210**) of **BC 302** utilizes time codes received in PTP timing messages (e.g., Sync messages) from **GM 301** via PP port **325** to sync an auxiliary clock (similar to auxiliary clock **212**) to the monitored remote master clock.

Referring now to FIG. 3C, which is a block diagram illustrating network **300** according to one embodiment. Network **300** illustrated in FIG. 3C is similar to network **300** shown in FIG. 3A, except that fault **388** has occurred. In FIG. 3C, the PTP ports and links in bold are those which are affected by fault **388**. Due to fault **388**, **BC 302** is no longer able to receive PTP messages from its main remote master clock (i.e., **GM 301**) via S port **324**. The failure to receive time codes prevents **BC 302** from syncing its local master clock (similar to master clock **211**) to **GM 301** via S port **324**. As a result, **BC 302** must select a new PTP port to be a slave port.

When a conventional PTP device switches to a new slave port (as illustrated in FIG. 1C), there is a possibility that a re-convergence may occur (i.e., a new synchronization tree may be formed), and as a result all downstream PTP devices are affected. For example, in FIG. 1C, when **BC 102** selects PTP port **123** as the new slave port, **BC 102** changes from being one BC level away from **GM 101** to three BC levels away from **GM 101**. This in turn requires all affected downstream PTP devices to select new master and slave ports. Such a re-convergence process requires a long time in order for all clocks in the network to settle to a reliable/accurate state. Embodiments of **BC 302** overcome these limitations by selecting PTP port **325** as the PP port because PTP port **325** is communicatively coupled to a remote PTP device (in this example, **GM 301**) that has a stepsRemoved value of one less than the stepsRemoved value of **BC 302**. By selecting PTP port **325** as the PP port, **BC 302** is able to prevent a re-convergence of the synchronization tree when the PP port is reconfigured to be a slave port. Here, before **BC 302** selects the new slave port, **BC 302** is one BC level away from **GM 301**. After **BC 302** selects the new slave port (i.e., PTP port **325**), **BC 302** remains one BC level away from **GM 301**. The synchronization tree remains unaffected by the selection of the new slave port, preventing all downstream PTP devices from having to select new master and slave ports. Thus, by utilizing mechanisms of the present invention, **BC 302** is able to prevent the formation of a new synchronization tree, thereby reducing the amount of time required by downstream PTP devices to sync up to the new master clock.

In one embodiment, in response to determining a failure to receive time codes from the main remote master clock via S port **324** (e.g., due to fault **388**), **BC 302** reconfigures PTP port **324** from slave state to master state. **BC 302** starts syncing its local master clock (similar to master clock **211**) to the auxiliary clock (similar to auxiliary clock **212**) corresponding to PP port **325**. Further, **BC 302** reconfigures PTP port **325** from PP state to slave state. Thus, **BC 302** has selected PTP port **325** to be its new slave port. Here, although **GM 301**

remains the main remote master clock, the time codes which BC 302 now syncs its local master clock to are those received via the new slave port 325.

The amount of time BC 302 requires to sync its local master clock to the new main remote master clock is less than the amount of time that a conventional PTP device would require because BC 302 is able to sync its local master clock to the auxiliary clock prior to syncing the local master clock to the new main remote master clock. In one embodiment, BC 302 also applies a phase slope limit (similar to phase slope limit 214) to the local master clock when the local master clock starts syncing to the auxiliary clock. In this way, the phase change in the local master clock can be controlled such that it would not disturb the timing of the downstream PTP devices (in this example, BC 305, SOOC 308, BC 306, and SOOC 309).

As described above, by using mechanisms of the present invention, BC 302 is able to handle fault 388 such that it is transparent to all downstream PTP devices. Here, BC 302 selects a PP port such that it prevents a new synchronization tree from forming when the PP port is reconfigured to be a slave port. By preventing the synchronization tree from changing, sync time is reduced. BC 302 further reduces the sync time by using time codes received via PTP port 325 while it was in the PP state to sync the auxiliary clock to the monitored remote master clock. To avoid disturbing the timing of downstream PTP devices, BC 302 applies a phase slope limit to control the phase change of the master clock.

Although fault 388 has been described as the cause for BC 302 failing to receive time codes via S port 324, one having ordinary skill in the art would recognize that the present invention is not limited to any particular type of fault. Embodiments of the present invention apply equally to any failure that prevents BC 302 from receiving time codes via S port 324.

Referring now back to FIG. 3A for a moment. As described above, S port 375 of BC 307 is communicatively coupled to M port 342 of BC 304. Thus, from the perspective of BC 307, BC 304 is the main remote master clock. BC 307 includes two PTP passive ports (i.e., PTP ports 371 and 374). BC 307 has identified (e.g., by utilizing a PP port identifier similar to PP port identifier 205) PTP passive port 374 as a PP port because PTP passive port 374 is communicatively coupled to a PTP device which has a stepsRemoved value of one less than the stepsRemoved value of BC 307. Here, BC 303 has a stepsRemoved value of 1 and BC 307 has a stepsRemoved value of 2. Thus, from the perspective of BC 307, BC 303 is the monitored remote master clock. As such, the clock manager (similar to clock manager 210) of BC 307 utilizes time codes received in PTP timing messages (e.g., Sync messages) from BC 303 via PP port 374 to sync an auxiliary clock (similar to auxiliary clock 212) to the monitored remote master clock.

Referring now to FIG. 3D, which is a block diagram illustrating network 300 according to one embodiment. Network 300 illustrated in FIG. 3D is similar to network 300 shown in FIG. 3A, except that fault 390 has occurred. In FIG. 3D, the PTP ports and links in bold are those which are affected by fault 390. Due to fault 390, BC 307 is no longer able to receive PTP messages from its main remote master clock (i.e., BC 304) via S port 375. The failure to receive time codes prevents BC 307 from syncing its local master clock (similar to master clock 211) to BC 304 via S port 375. As a result, BC 307 must select a new PTP port to be a slave port.

When a conventional PTP device switches to a new slave port (as illustrated in FIG. 1C), there is a possibility that a re-convergence may occur (i.e., a new synchronization tree may be formed), and as a result all downstream PTP devices

are affected. For example, in FIG. 1C, when BC 102 selects PTP port 123 as the new slave port, BC 102 changes from being one BC level away from GM 101 to three BC levels away from GM 101. This in turn requires all affected downstream PTP devices to select new master and slave ports. Such a re-convergence process requires a long time in order for all clocks in the network to settle to a reliable/accurate state. Embodiments of BC 307 overcome these limitations by selecting PTP port 374 (as opposed to PTP port 371) as the PP port because PTP port 374 is communicatively coupled to a remote PTP device (in this example, BC 303) that has a stepsRemoved value of one less than the stepsRemoved value of BC 307. By selecting PTP port 374 (as opposed to PTP port 371) as the PP port, BC 307 is able to prevent a re-convergence of the synchronization tree when the PP port is reconfigured to be a slave port. Here, before BC 307 selects the new slave port, BC 307 is two BC levels away from GM 301. After BC 307 selects the new slave port (i.e., PTP port 374), BC 307 remains two BC levels away from GM 301. The synchronization tree remains unaffected by the selection of the new slave port, preventing all downstream PTP devices from having to select new master and slave ports. Thus, by utilizing mechanisms of the present invention, BC 307 is able to prevent the formation of a new synchronization tree, thereby reducing the amount of time required by downstream PTP devices to sync up to the new master clock. Note that a conventional PTP device, without the benefits of PP port identifier 205 of the present invention, may select PTP port 371 as the new slave port. This would cause a re-convergence of the synchronization tree because BC 307 would be three BC levels away from GM 301 (i.e., one more BC level away from GM 301 as compared to before the new slave port was selected).

In one embodiment, in response to determining a failure to receive time codes from the main remote master clock via S port 375 (e.g., due to fault 390), BC 307 reconfigures PTP port 375 from slave state to master state. BC 307 starts syncing its local master clock (similar to master clock 211) to the auxiliary clock (similar to auxiliary clock 212) corresponding to PP port 374. Further, BC 307 reconfigures PTP port 374 from PP state to slave state. Thus, BC 307 has selected PTP port 374 to be its new slave port, and the time codes which BC 307 now syncs its local master clock to are those received via new slave port 374.

The amount of time BC 307 requires to sync its local master clock to the new main remote master clock is less than the amount of time that a conventional PTP device would require because BC 307 is able to sync its local master clock to the auxiliary clock prior to syncing the local master clock to the new main remote master clock. In one embodiment, BC 307 also applies a phase slope limit (similar to phase slope limit 214) to the local master clock when the local master clock starts syncing to the auxiliary clock. In this way, the phase change in the local master clock can be controlled such that it would not disturb the timing of the downstream PTP devices (in this example, SOOC 310).

As described above, by using mechanisms of the present invention, BC 307 is able to handle fault 390 such that it is transparent to all downstream PTP devices. Here, BC 307 selects a PP port such that it prevents a new synchronization tree from forming when the PP port is reconfigured to be a slave port. By preventing the synchronization tree from changing, sync time is reduced. BC 307 further reduces the sync time by using time codes received via PTP port 374 while it was in the PP state to sync the auxiliary clock to the monitored remote master clock. To avoid disturbing the tim-

ing of downstream PTP devices, BC 307 applies a phase slope limit to control the phase change of the master clock.

Although fault 390 has been described as the cause for BC 307 failing to receive time codes via S port 375, one having ordinary skill in the art would recognize that the present invention is not limited to any particular type of fault. Embodiments of the present invention apply equally to any failure that prevents BC 307 from receiving time codes via S port 375.

FIG. 4 is a flow diagram illustrating method 400 for maintaining an auxiliary clock according to one embodiment. For example, method 400 can be performed by PP port identifier 205 and clock manager 210, which can be implemented in software, firmware, hardware, or any combination thereof. The operations of this and other flow diagrams will be described with reference to the exemplary embodiments of the other diagrams. However, it should be understood that the operations of the flow diagrams can be performed by embodiments of the invention other than those discussed with reference to these other diagrams, and the embodiments of the invention discussed with reference to these other diagrams can perform operations different than those discussed with reference to the flow diagrams.

Referring now to FIG. 4, at block 405, the PP port identifier determines a plurality of PTP passive ports associated with a local network device, wherein each of the plurality of PTP passive ports is communicatively coupled to a corresponding peer PTP master port. For example, the PP port identifier of network device 307 determines PTP ports 371 and 374 as PTP passive ports which communicatively couple to corresponding peer PTP master ports 363 and 333, respectively.

At block 410, the PP port identifier selects, from the determined plurality of PTP passive ports, one or more PTP passive ports wherein the corresponding peer PTP master port is associated with a remote network device that has a stepsRemoved value that is one less than a stepsRemoved value of the local network device. For example, the PP port identifier of network device 307 identifies PTP passive port 374 as having a peer PTP master port 333 associated with remote network device 303 which has a stepsRemoved value of one less than the stepsRemoved value of network device 307. Here, network device 303 has a stepsRemoved value of one, and network device 307 has a stepsRemoved value of two.

At block 415, the PP port identifier optionally configures all PTP passive ports of the selected PTP passive ports to be PP ports. For example, the PP port identifier of network device 307 configures PTP passive port 374 to be the PP port. Alternatively, at block 420, the PP port identifier configures a predetermined number of the selected PTP passive ports with a corresponding peer PTP master port that has a lowest port identity to be a PP port. For example, if network device 307 included multiple PTP passive ports that communicatively coupled to PTP devices having a stepsRemoved value that is one less than the stepsRemoved value of network device 307, the PP port identifier of network device 307 can configure a predetermined number of such PTP passive ports to be PP ports. Here, the predetermined number can be a percentage or raw number.

At block 425, the clock manager maintains an auxiliary clock for each PP port using timing information included in timing messages received via the respective PP port. For example, the clock manager of network device 307 utilizes time codes included in PTP timing messages (e.g., PTP Sync messages) received from network device 303 via PP port 374 to maintain an auxiliary clock.

FIG. 5 is a flow diagram illustrating method 500 for reducing the time required for a PTP device to sync to a new master

clock, according to one embodiment. For example, method 500 can be performed by clock manager 210, which can be implemented in software, firmware, hardware, or any combination thereof.

Referring now to FIG. 5, at block 505, the clock manager synchronizes a local PTP master clock to a first PTP master clock maintained by a first remote network device utilizing timing information included in timing messages received from the first remote network device via a PTP slave port associated with a local network device. For example, the clock manager of network device 307 synchronizes its local PTP master clock to the PTP master clock maintained by network device 304 using time codes included in PTP timing messages (e.g., PTP Sync messages) received from network device 304 via PTP slave port 375.

At block 510, the clock manager maintains a local auxiliary clock for each protective passive (PP) port, wherein each auxiliary clock synchronizes its frequency to a respective monitored master clock using information included in PTP timing messages received via each respective PP port. For example, the clock manager of network device 307 maintains an auxiliary clock corresponding to PP port 374, by syncing the auxiliary clock to the PTP master clock maintained by network device 303 using time codes included in PTP timing messages (e.g., PTP Sync messages) received from network device 303 via PP port 374.

At block 515, the clock manager determines a failure to receive timing messages from the first remote network device via the PTP slave port associated with the local network device. For example, the clock manager of network device 307 determines that PTP timing messages can no longer be received from network device 304 via S port 375 (e.g., due to fault 390).

At block 520, the clock manager configures the PTP slave port to be a PTP master port, and configure a first PP port associated with the local network device to be a new PTP slave port, wherein the first PP port is communicatively coupled to a second remote network device. For example, the clock manager of network device 307 configures PTP slave port 375 to be a master port, and configures PP port 374 to be a new slave port.

At block 525, the clock manager synchronizes the local master clock frequency to the frequency of the auxiliary clock corresponding to the first PP port, using phase slope limiting to control the timing disturbance to downstream slave devices. For example, the clock manager of network device 307 syncs the frequency of the local master clock to the frequency of the auxiliary clock corresponding to PP port 374, using a phase slope limit (similar to phase slope limit 214) to control the phase change of the local master clock.

At block 530, the clock manager synchronizes the local master clock to the monitored master clock corresponding to the first PP port using timing information included in PTP timing messages received via the new PTP slave port. For example, the clock manager of network device 307 syncs the local master clock to the master clock maintained by network device 303 using time codes included in PTP timing messages (e.g., PTP Sync messages) received via new slave port 374.

Some portions of the preceding detailed descriptions have been presented in terms of algorithms and symbolic representations of transactions on data bits within a computer memory. These algorithmic descriptions and representations are the ways used by those skilled in the data processing arts to most effectively convey the substance of their work to others skilled in the art. An algorithm is here, and generally, conceived to be a self-consistent sequence of transactions leading to a desired result. The transactions are those requir-

ing physical manipulations of physical quantities. Usually, though not necessarily, these quantities take the form of electrical or magnetic signals capable of being stored, transferred, combined, compared, and otherwise manipulated. It has proven convenient at times, principally for reasons of common usage, to refer to these signals as bits, values, elements, symbols, characters, terms, numbers, or the like.

It should be borne in mind, however, that all of these and similar terms are to be associated with the appropriate physical quantities and are merely convenient labels applied to these quantities. Unless specifically stated otherwise as apparent from the above discussion, it is appreciated that throughout the description, discussions utilizing terms such as “processing” or “computing” or “calculating” or “determining” or “displaying” or the like, refer to the action and processes of a computer system, or similar electronic computing device, that manipulates and transforms data represented as physical (electronic) quantities within the computer system’s registers and memories into other data similarly represented as physical quantities within the computer system memories or registers or other such information storage, transmission or display devices.

The algorithms and displays presented herein are not inherently related to any particular computer or other apparatus. Various general-purpose systems may be used with programs in accordance with the teachings herein, or it may prove convenient to construct more specialized apparatus to perform the required method transactions. The required structure for a variety of these systems will appear from the description above. In addition, embodiments of the present invention are not described with reference to any particular programming language. It will be appreciated that a variety of programming languages may be used to implement the teachings of embodiments of the invention as described herein.

In the foregoing specification, embodiments of the invention have been described with reference to specific exemplary embodiments thereof. It will be evident that various modifications may be made thereto without departing from the broader spirit and scope of the invention as set forth in the following claims. The specification and drawings are, accordingly, to be regarded in an illustrative sense rather than a restrictive sense.

Throughout the description, embodiments of the present invention have been presented through flow diagrams. It will be appreciated that the order of transactions and transactions described in these flow diagrams are only intended for illustrative purposes and not intended as a limitation of the present invention. One having ordinary skill in the art would recognize that variations can be made to the flow diagrams without departing from the broader spirit and scope of the invention as set forth in the following claims.

What is claimed is:

1. A method in a first network device for supporting Precision Time Protocol (PTP) in a network, the method comprising:

receiving, by a first PTP port associated with the first network device configured as a PTP slave port, PTP timing messages from a second PTP port associated with a second network device configured as a PTP master port, wherein the PTP timing messages include timing information of a PTP master clock maintained by the second network device;

maintaining a PTP master clock based on the timing information included in the PTP timing messages received from the second network device via the first PTP port;

receiving, by a third PTP port associated with the first network device configured as a PTP passive port, PTP

timing messages from a fourth PTP port associated with a third network device configured as a PTP master port, wherein the PTP timing messages include timing information of a PTP master clock maintained by the third network device;

determining the third PTP port is a protective passive port based on a stepsRemoved value associated with the third network device, wherein a stepsRemoved value indicates a number of boundary clock levels a respective network device is away from a PTP grandmaster clock of the network; and

in response to determining the third PTP port is a protective passive port, maintaining a PTP auxiliary clock based on the timing information included in the PTP timing messages received from the third network device via the third PTP port, wherein in an event that the first network device fails to receive PTP timing messages from the second network device via the first PTP port, the PTP auxiliary clock is utilized by the first network device to synchronize its PTP master clock to the PTP master clock maintained by the third network device.

2. The method of claim **1**, wherein determining the third PTP port is a protective passive port comprises:

determining the third network device has a stepsRemoved value that is one less than a stepsRemoved value of the first network device.

3. The method of claim **2**, further comprising:

receiving, by a fifth PTP port associated with the first network device configured as a PTP passive port, PTP timing messages from a sixth PTP port associated with a fourth network device configured as a PTP master port, wherein the PTP timing messages include timing information of a PTP master clock maintained by the fourth network device; and

in response to determining the fourth network device has a stepsRemoved value that is equal to a stepsRemoved value of the first network device, determining the fifth PTP port is a non-protective passive port.

4. The method of claim **1**, wherein determining the third PTP port is a protective passive port comprises:

receiving, by a fifth PTP port associated with the first network device configured as a PTP passive port, PTP timing messages from a sixth PTP port associated with a fourth network device configured as a PTP master port, wherein the PTP timing messages include timing information of a PTP master clock maintained by the fourth network device;

determining the third network device has a stepsRemoved value that is equal to a stepsRemoved value of the fourth network device; and

determining the fourth PTP port has a port identity (ID) that is less than a port ID of the sixth PTP port associated with the fourth network device.

5. The method of claim **1**, further comprising:

in response to determining a failure to receive PTP timing messages from the second network device via the first PTP port:

configuring the first PTP port to be a PTP master port, configuring the third PTP port to be a PTP slave port, and utilizing information of the PTP auxiliary clock to synchronize the PTP master clock maintained by the first network device to the PTP master clock maintained by the third network device.

6. The method of claim **5**, further comprising applying a phase slope limit to the PTP master clock maintained by the first network device after the third PTP port has been configured to be a PTP slave port.

21

7. The method of claim 1, wherein the second network device and the third network device are a same network device configured to serve as a PTP grandmaster clock of the network.

8. The method of claim 1, wherein the second network device and the third network device are different network devices, wherein the second network device and the third network device are configured to serve as a PTP boundary clock of the network.

9. A first network device for supporting Precision Time Protocol (PTP) in a network, the first network device comprising:

a first PTP port associated with the first network device configured as a PTP slave port, operative to receive PTP timing messages from a second PTP port associated with a second network device configured as a PTP master port, wherein the PTP timing messages include timing information of a PTP master clock maintained by the second network device;

a third PTP port associated with the first network device configured as a PTP passive port, operative to receive PTP timing messages from a fourth PTP port associated with a third network device configured as a PTP master port, wherein the PTP timing messages include timing information of a PTP master clock maintained by the third network device;

a set of one or more processors; and

a non-transitory machine-readable storage medium containing instructions, which when executed by the set of one or more processors, cause the first network device to:

maintain a PTP master clock based on the timing information included in the PTP timing messages received from the second network device via the first PTP port, determine the third PTP port is a protective passive port based on a stepsRemoved value associated with the third network device, wherein a stepsRemoved value indicates a number of boundary clock levels a respective network device is away from a PTP grandmaster clock of the network, and

in response to determining the third PTP port is a protective passive port, maintain a PTP auxiliary clock based on the timing information included in the PTP timing messages received from the third network device via the third PTP port, wherein in an event that the first network device fails to receive PTP timing messages from the second network device via the first PTP port, the PTP auxiliary clock is utilized by the first network device to synchronize its PTP master clock to the PTP master clock maintained by the third network device.

10. The first network device of claim 9, wherein the instructions that cause the first network device to determine the third PTP port is a protective passive port comprises instructions, which when executed by the set of one or more processors, cause the first network device to determine the third network device has a stepsRemoved value that is one less than a stepsRemoved value of the first network device.

11. The first network device of claim 10, further comprising:

a fifth PTP port associated with the first network device configured as a PTP passive port, operative to receive PTP timing messages from a sixth PTP port associated with a fourth network device configured as a PTP master port, wherein the PTP timing messages include timing information of a PTP master clock maintained by the fourth network device, wherein

22

the non-transitory machine-readable storage medium further containing instructions, which when executed by the set of one or more processors, cause the first network device to in response to determining the fourth network device has a stepsRemoved value that is equal to a stepsRemoved value of the first network device, determine the fifth PTP port is a non-protective passive port.

12. The first network device of claim 9, further comprising: a fifth PTP port associated with the first network device configured as a PTP passive port, operative to receive PTP timing messages from a sixth PTP port associated with a fourth network device configured as a PTP master port, wherein the PTP timing messages include timing information of a PTP master clock maintained by the fourth network device, wherein the instructions that cause the first network device to determine the third PTP port is a protective passive port comprises instructions, which when executed by the set of one or more processors, cause the first network device to:

determine the third network device has a stepsRemoved value that is equal to a stepsRemoved value of the fourth network device, and

determine the fourth PTP port associated with the third network device has a port identity (ID) that is less than a port ID of the sixth PTP port associated with the fourth network device.

13. The first network device of claim 9, wherein the non-transitory machine-readable storage medium further containing instructions, which when executed by the set of one or more processors, cause the first network device to in response to determining a failure to receive PTP timing messages from the second network device via the first PTP port:

configure the first PTP port to be a PTP master port, configure the third PTP port to be a PTP slave port, and utilize information of the PTP auxiliary clock to synchronize the PTP master clock maintained by the first network device to the PTP master clock maintained by the third network device.

14. The first network device of claim 13, wherein the non-transitory machine-readable storage medium further containing instructions, which when executed by the set of one or more processors, cause the first network device to apply a phase slope limit to the PTP master clock maintained by the first network device after the third PTP port has been configured to be a PTP slave port.

15. The first network device of claim 9, wherein the second network device and the third network device are a same network device configured to serve as a PTP grandmaster clock of the network.

16. The first network device of claim 9, wherein the second network device and the third network device are different network devices, wherein the second network device and the third network device are configured to serve as a PTP boundary clock of the network.

17. A non-transitory computer-readable storage medium having computer instructions stored therein, which when executed by a processor of a first network device for supporting Precision Time Protocol (PTP) in a network, cause the first network device to perform operations comprising:

receiving, by a first PTP port associated with the first network device configured as a PTP slave port, PTP timing messages from a second PTP port associated with a second network device configured as a PTP master port, wherein the PTP timing messages include timing information of a PTP master clock maintained by the second network device;

23

maintaining a PTP master clock based on the timing information included in the PTP timing messages received from the second network device via the first PTP port; receiving, by a third PTP port associated with the first network device configured as a PTP passive port, PTP timing messages from a fourth PTP port associated with a third network device configured as a PTP master port, wherein the PTP timing messages include timing information of a PTP master clock maintained by the third network device;

determining the third PTP port is a protective passive port based on a stepsRemoved value associated with the third network device, wherein a stepsRemoved value indicates a number of boundary clock levels a respective network device is away from a PTP grandmaster clock of the network; and

in response to determining the third PTP port is a protective passive port, maintaining a PTP auxiliary clock based on the timing information included in the PTP timing messages received from the third network device via the third PTP port, wherein in an event that the first network device fails to receive PTP timing messages from the second network device via the first PTP port, the PTP auxiliary clock is utilized by the first network device to synchronize its PTP master clock to the PTP master clock maintained by the third network device.

18. The non-transitory computer-readable storage medium of claim 17, wherein determining the third PTP port is a protective passive port comprises:

determining the third network device has a stepsRemoved value that is one less than a stepsRemoved value of the first network device.

19. The non-transitory computer-readable storage medium of claim 18, the operations further comprising:

receiving, by a fifth PTP port associated with the first network device configured as a PTP passive port, PTP timing messages from a sixth PTP port associated with a fourth network device configured as a PTP master port, wherein the PTP timing messages include timing information of a PTP master clock maintained by the fourth network device; and

in response to determining the fourth network device has a stepsRemoved value that is equal to a stepsRemoved

24

value of the first network device, determining the fifth PTP port is a non-protective passive port.

20. The non-transitory computer-readable storage medium of claim 17, wherein determining the third PTP port is a protective passive port comprises:

receiving, by a fifth PTP port associated with the first network device configured as a PTP passive port, PTP timing messages from a sixth PTP port associated with a fourth network device configured as a PTP master port, wherein the PTP timing messages include timing information of a PTP master clock maintained by the fourth network device;

determining the third network device has a stepsRemoved value that is equal to a stepsRemoved value of the fourth network device; and

determining the fourth PTP port has a port identity (ID) that is less than a port ID of the sixth PTP port associated with the fourth network device.

21. The non-transitory computer-readable storage medium of claim 17, the operations further comprising:

in response to determining a failure to receive PTP timing messages from the second network device via the first PTP port:

configuring the first PTP port to be a PTP master port, configuring the third PTP port to be a PTP slave port, and utilizing information of the PTP auxiliary clock to synchronize the PTP master clock maintained by the first network device to the PTP master clock maintained by the third network device.

22. The non-transitory computer-readable storage medium of claim 21, the operations further comprising applying a phase slope limit to the PTP master clock maintained by the first network device after the third PTP port has been configured to be a PTP slave port.

23. The non-transitory computer-readable storage medium of claim 17, wherein the second network device and the third network device are a same network device configured to serve as a PTP grandmaster clock of the network.

24. The non-transitory computer-readable storage medium of claim 17, wherein the second network device and the third network device are different network devices, wherein the second network device and the third network device are configured to serve as a PTP boundary clock of the network.

* * * * *