

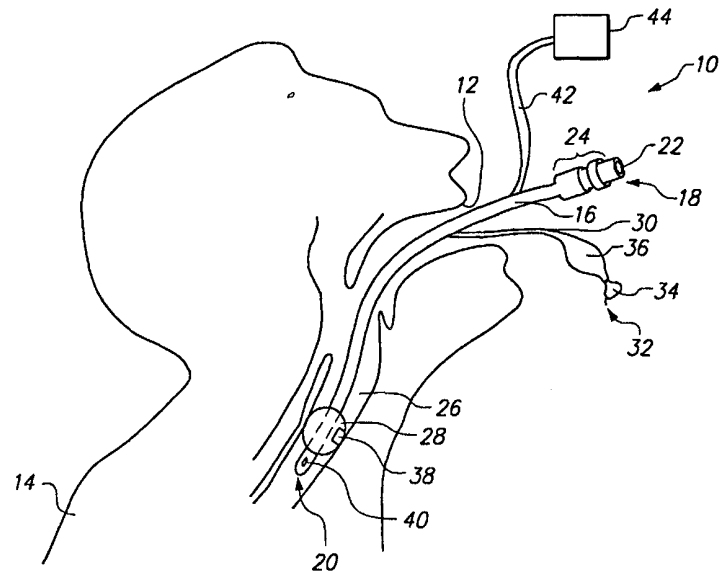

INTERNATIONAL APPLICATION PUBLISHED UNDER THE PATENT COOPERATION TREATY (PCT)

<p>(51) International Patent Classification ⁷ : A61B 5/00, A61M 16/04</p>	<p>A1</p>	<p>(11) International Publication Number: WO 00/48510 (43) International Publication Date: 24 August 2000 (24.08.00)</p>
<p>(21) International Application Number: PCT/US00/04305 (22) International Filing Date: 18 February 2000 (18.02.00) (30) Priority Data: 09/252,633 19 February 1999 (19.02.99) US (71) Applicant: INSTITUTE OF CRITICAL CARE MEDICINE [US/US]; 1695 North Sunrise Way, Palm Springs, CA 92262 (US). (72) Inventors: WEIL, Max, Harry; 3810 South Mission Hills Road #303, Northbrook, IL 60062 (US). TANG, Wanchun; 40456 Periwinkle Court, Palm Desert, CA 92260 (US). BISERA, Jose; 1534 Apacapa Drive, Camarillo, CA 93010 (US). (74) Agents: REED, Dianne, E. et al.; Reed & Associates, 3282 Alpine Road, Portola Valley, CA 94028 (US).</p>	<p>(81) Designated States: AE, AL, AM, AT, AU, AZ, BA, BB, BG, BR, BY, CA, CH, CN, CR, CU, CZ, DE, DK, DM, EE, ES, FI, GB, GD, GE, GH, GM, HR, HU, ID, IL, IN, IS, JP, KE, KG, KP, KR, KZ, LC, LK, LR, LS, LT, LU, LV, MA, MD, MG, MK, MN, MW, MX, NO, NZ, PL, PT, RO, RU, SD, SE, SG, SI, SK, SL, TJ, TM, TR, TT, TZ, UA, UG, UZ, VN, YU, ZA, ZW, ARIPO patent (GH, GM, KE, LS, MW, SD, SL, SZ, TZ, UG, ZW), Eurasian patent (AM, AZ, BY, KG, KZ, MD, RU, TJ, TM), European patent (AT, BE, CH, CY, DE, DK, ES, FI, FR, GB, GR, IE, IT, LU, MC, NL, PT, SE), OAPI patent (BF, BJ, CF, CG, CI, CM, GA, GN, GW, ML, MR, NE, SN, TD, TG).</p> <p>Published <i>With international search report.</i></p>	

(54) Title: DEVICE AND METHOD FOR ASSESSING PERFUSION FAILURE IN A PATIENT DURING ENDOTRACHEAL INTUBATION



(57) Abstract

A device, and method are provided for assessing impairment of blood circulation in a patient, such as that in perfusion failure, wherein the patient requires mechanical ventilatory support. The invention involves measurement of PCO₂ (partial pressure of carbon dioxide) within the lower respiratory tract of the patient, using a device that includes an endotracheal breathing tube (10) for introducing air from an air supply pump into a patient's lungs. A carbon dioxide sensor (38) is provided as an integral part of that device, i.e., it is physically connected to the endotracheal breathing tube in a manner that allows for PCO₂ measurement along the sidewall of the patient's trachea.

FOR THE PURPOSES OF INFORMATION ONLY

Codes used to identify States party to the PCT on the front pages of pamphlets publishing international applications under the PCT.

AL	Albania	ES	Spain	LS	Lesotho	SI	Slovenia
AM	Armenia	FI	Finland	LT	Lithuania	SK	Slovakia
AT	Austria	FR	France	LU	Luxembourg	SN	Senegal
AU	Australia	GA	Gabon	LV	Latvia	SZ	Swaziland
AZ	Azerbaijan	GB	United Kingdom	MC	Monaco	TD	Chad
BA	Bosnia and Herzegovina	GE	Georgia	MD	Republic of Moldova	TG	Togo
BB	Barbados	GH	Ghana	MG	Madagascar	TJ	Tajikistan
BE	Belgium	GN	Guinea	MK	The former Yugoslav Republic of Macedonia	TM	Turkmenistan
BF	Burkina Faso	GR	Greece			TR	Turkey
BG	Bulgaria	HU	Hungary	ML	Mali	TT	Trinidad and Tobago
BJ	Benin	IE	Ireland	MN	Mongolia	UA	Ukraine
BR	Brazil	IL	Israel	MR	Mauritania	UG	Uganda
BY	Belarus	IS	Iceland	MW	Malawi	US	United States of America
CA	Canada	IT	Italy	MX	Mexico	UZ	Uzbekistan
CF	Central African Republic	JP	Japan	NE	Niger	VN	Viet Nam
CG	Congo	KE	Kenya	NL	Netherlands	YU	Yugoslavia
CH	Switzerland	KG	Kyrgyzstan	NO	Norway	ZW	Zimbabwe
CI	Côte d'Ivoire	KP	Democratic People's Republic of Korea	NZ	New Zealand		
CM	Cameroon		Republic of Korea	PL	Poland		
CN	China	KR	Republic of Korea	PT	Portugal		
CU	Cuba	KZ	Kazakstan	RO	Romania		
CZ	Czech Republic	LC	Saint Lucia	RU	Russian Federation		
DE	Germany	LI	Liechtenstein	SD	Sudan		
DK	Denmark	LK	Sri Lanka	SE	Sweden		
EE	Estonia	LR	Liberia	SG	Singapore		

DEVICE AND METHOD FOR ASSESSING PERFUSION FAILURE
IN A PATIENT DURING ENDOTRACHEAL INTUBATION

5

TECHNICAL FIELD

The present invention relates generally to methods and devices for assessing perfusion failure in a patient. More particularly, the invention relates to assessment of perfusion failure in a patient by measuring the localized partial pressure of carbon dioxide at an endotracheal site.

10

BACKGROUND ART

Very low blood flow, or low "systemic perfusion," is typically due to low aortic pressure and can be caused by a number of factors, including hemorrhage, sepsis and cardiac arrest. When there is a reduced flow of blood from the heart, the body directs a higher portion of blood to critical organs, such as the brain, which will not survive long without a continuous supply of blood, while restricting the flow to less critical organs, such as the stomach and intestines, whose survival is not as threatened by a temporary large reduction in blood flow. Physicians commonly take advantage of this phenomenon by taking measurements in the stomach and intestine to assess perfusion failure.

20

Assessment of CO₂ concentration in the less critical organs, i.e., those organs to which blood flow is reduced during perfusion failure, is useful in perfusion assessment. Carbon dioxide production, which is associated with metabolism, continues even during low blood flow. Because CO₂ is not rapidly carried away during low blood flow, the concentration of CO₂ increases, which in turn results in a decrease in pH and an increase in partial pressure of CO₂ (PCO₂) in the less critical organs. Therefore, perfusion failure is commonly assessed by measuring pH or PCO₂ at these sites, especially in the stomach and intestines. For examples of catheters used to assess pH or PCO₂ in the stomach or intestines, see, *e.g.*, U.S. Patent Nos. 3,905,889 to Macur, 4,016,863 Brantigan, 4,632,119 to Reichstein, 4,643,192 to Fiddian-Green, 4,981,470 to Bombeck, IV, 5,105,812 to Corman, 5,117,827 to Stuebe et al. 5,174,290 to Fiddian-

30

Green, 5,341,803 to Goldberg, 5,411,022 to McCue, 5,423,320 to Salzman et al.,
5,456,251 to Fiddian-Green, and 5,788,631 to Fiddian-Green et al.

The measurement of PCO_2 to determine the extent of perfusion failure has
commonly been done by threading a catheter through the nasal passage, past the
5 epiglottis, through the esophagus, past the esophageal sphincter, and into the stomach,
and sometimes through the stomach and into the intestines. Alternatively, measurement
has been conducted in the colon, with a catheter being threaded through the anus.
These procedures are obviously quite invasive and can cause harm and discomfort to a
patient. Moreover, insertion of the catheter in this manner is also complex and time-
10 consuming.

U.S. Patent No. 5,579,763 to Weil et al., describes the introduction of a catheter
with a carbon dioxide sensor through the nasal or oral passage, past the epiglottis, and
into the esophagus so that the catheter and sensor lay within the esophagus. This
method can be used to accurately assess perfusion failure by measuring PCO_2 in the
15 patient's esophagus of a patient, rather than in the stomach and/or intestine. Tests
showed that measurements of PCO_2 in the esophagus are closely correlated with aortic
pressure, and, furthermore, that measurements made in the esophagus are even more
closely correlated to aortic pressure than measurements of CO_2 in the stomach. This
procedure was advantageous in that the procedure's invasiveness was reduced and CO_2
20 generated by digestive fluids in the stomach did not affect measurements since the
esophageal sphincter blocks such gas. However, the insertion of the catheter still
constituted considerable invasion and thus risk of harm to the patient. Furthermore,
extension of the catheter extended past the epiglottis exposed the patient to the risk of
regurgitation of stomach contents including stomach acids.

25 In International Patent Publication No. WO 99/16346, published April 8, 1999,
the present inventors described a less invasive method for assessing impairment of
blood circulation in a patient, such as that in perfusion failure, by measurement of PCO_2
in the upper digestive and/or respiratory tract of a patient. As explained in the
aforementioned PCT application, that method involves introduction of a carbon
30 dioxide sensor into the upper digestive and/or upper respiratory tract of a patient,
without passing the sensor down through or beyond the patient's epiglottis. The carbon
dioxide sensor is placed adjacent a mucosal surface within the upper digestive and/or

respiratory tract, *e.g.*, within a patient's mouth, inside a patient's nose, or at a site along the wall of the esophagus.

Patients who require mechanical ventilatory support pose special problems in measurement of PCO_2 using the aforementioned methods. By "mechanical ventilatory support" is meant an apparatus that supports the ventilatory function of the respiratory and improves oxygenation by delivering high oxygen content gas into the endotracheal region of a patient. The apparatus is generally termed a "breathing tube" or "endotracheal tube" ("ETT"). Respiratory failure is the primary indication for use of such respiratory support systems, including hypoxemic respiratory failure, as may result from pulmonary conditions such as pneumonia, pulmonary edema, pulmonary hemorrhage and respiratory distress syndrome, and hypercarbic respiratory failure, such as may be associated with disease states causing inadequate alveolar ventilation to meet metabolic demands. Respiratory support systems are also necessary during many surgical procedures. Mechanical ventilation support systems are known in the art and described, for example, in U.S. Patent Nos. 4,502,482 to DeLuccia, deceased et al., 5,005,573 to Buchanan, 5,452,715 to Boussignac et al., 5,606,968 to Mang, 5,765,559 to Kim, 5,791,338 to Merchant et al., 5,803,898 to Bashour, and 5,806,516 to Beattie.

For seriously ill patients who require mechanical ventilatory support and are thus already burdened with an endotracheal intubation system, introduction of an additional system for PCO_2 measurement--such as described in U.S. Patent No. 5,579,763 and International Patent Publication No. WO 99/16346--would be logistically difficult and unnecessary if the measurement could be determined using the existing endotracheal system.

There is accordingly a need in the art for a method to measure perfusion failure and to monitor the effectiveness of methods taken to increase perfusion, *e.g.*, blood infusion or the like, that are well-suited for use in a mechanically ventilated patient.

DISCLOSURE OF THE INVENTION

Methods and devices are provided for assessing impairment of blood circulation in a patient, such as that in perfusion failure, by measurement of PCO_2 (partial pressure of carbon dioxide) within the lower respiratory tract of the patient. The method
5 comprises introducing a carbon dioxide sensor into the lower respiratory tract of a patient, at a region within the trachea (*e.g.*, below the larynx and above the bronchi). The carbon dioxide sensor is attached to and/or physically incorporated within an endotracheal breathing tube. Before the work of the present inventors, it was believed that increases in partial pressure of carbon dioxide during perfusion failure were
10 localized phenomena; however, applicants have discovered that increases in tissue CO_2 occur throughout the body during perfusion failure, and that such increases in tissue CO_2 can be measured at an endotracheal site using the device and method of the invention.

As the invention involves a carbon dioxide sensor appended to an endotracheal
15 breathing tube, the invasiveness involved in introducing the carbon dioxide sensor into the endotracheal area of the patient is no greater than that involved in the insertion of the breathing tube *per se*. The sensor may be incorporated into any appropriate portion of the endotracheal tube, *e.g.*, on a balloon or cuff portion of the endotracheal apparatus, or along the cannula portion of the endotracheal tube, so long as the sensor is
20 suitably positioned along the tracheal wall for PCO_2 measurement. Preferably, the sensor is an optical CO_2 sensor. The output of the sensor can be detected by a device which electronically converts the sensor output to provide a CO_2 concentration value. The device can further sense the rate of change of CO_2 concentration with time to indicate the patient's condition.

25 Accordingly, in one aspect the invention features a device for assessing perfusion failure in a patient in need of mechanical ventilation, wherein the device is composed of: a mechanical ventilation support system that includes an endotracheal breathing tube provided with a carbon dioxide sensor means for detecting the partial pressure of carbon dioxide (PCO_2) along the interior wall of the patient's trachea; and
30 an indicating means operably connected to the sensor means for indicating the degree of

perfusion failure of the patient associated with the detected partial pressure of carbon dioxide.

In another aspect the invention features a method for assessing perfusion failure of a patient requiring mechanical ventilation, the method involving the steps of

5 introducing an endotracheal breathing tube into the trachea of the patient as part of a mechanical ventilation support system, wherein the endotracheal breathing tube provided with a carbon dioxide sensor means for detecting the partial pressure of carbon dioxide (PCO₂) along the interior wall of the trachea; using the carbon dioxide sensor means to measure the partial pressure of carbon dioxide within the patient's

10 trachea, along the sidewall thereof; and relaying the partial pressure of carbon dioxide so measured to an indicating means that displays the measured PCO₂ value, which in turn correlates to the degree of perfusion failure in the patient. A partial pressure of carbon dioxide within the patient's trachea that is substantially greater than a normal partial pressure of carbon dioxide is indicative of perfusion failure in the patient, as is a

15 partial pressure of carbon dioxide within the patient's trachea that increases over time.

One advantage of the invention is that perfusion can be assessed in a patient in a manner that is no more invasive than introducing an endotracheal breathing tube into the patient's trachea, as the perfusion assessment means is incorporated within such a breathing tube. Thus, the invention is advantageous in that it involves minimal

20 additional discomfort or risk of harm to the patient.

Another advantage of the invention is that perfusion can be readily assessed in a patient suffering from perfusion failure associated with any of a variety of causes, including, but not limited to physical trauma, infection, hypothermia, cardiogenic shock (*e.g.*, acute myocardial infarction, aneurysm, or arrhythmia), obstructive shock (*e.g.*,

25 pulmonary embolism), hypovolemic shock (*e.g.*, due to hemorrhage or fluid depletion), and distributive shock (*e.g.*, due to sepsis, exposure to toxins, or anaphylaxis). The invention is readily adapted for assessment of perfusion failure through PCO₂ measurement in connection with any situation in which a patient is placed on a mechanical ventilation device or is otherwise subjected to endotracheal intubation

30 (*e.g.*, newborns or premature newborns, patients undergoing surgery requiring general anesthesia, *etc.*) The sensitivity of the methods and devices of the invention further

allow for assessment of perfusion across a wide range of perfusion failure severity, thereby providing a means to accurately monitor the patient's condition.

Still another advantage of the invention is that the devices and methods can be readily adapted for use in alert, semi-conscious, or unconscious patients. and can be
5 further adapted for accurate assessment of perfusion in a patient for a period lasting for only minutes to hours or days.

The novel features of the invention are set forth with particularity in the appended claims. The invention will be best understood from the following description when read in conjunction with the accompanying drawings.

10

BRIEF DESCRIPTION OF THE DRAWINGS

Fig. 1 is a pictorial diagram showing the positioning of the perfusion assessing system of the invention within a patient's trachea.

15 Fig. 2 is an electrical block diagram of one embodiment of a circuit for processing output data from a PCO_2 sensor located within a patient's trachea.

Fig. 3 is a graph showing the results of a first feasibility study conducted with rats using endotracheal tubes modified to accommodate a PCO_2 sensor; in the graph, " P_ECO_2 " represents endotracheal PCO_2 (in mm Hg), " P_GCO_2 " represents gastric wall
20 PCO_2 (in mm Hg), and "MAP" represents the mean arterial pressure (again, in mm Hg).

Fig. 4 is a graph showing the results of a second feasibility study conducted with rats using endotracheal tubes modified to accommodate a PCO_2 sensor, with abbreviations and units as set forth above with respect to Fig. 3.

Fig. 5 is a graph showing the endotracheal PCO_2 (mm Hg; upper panel) in
25 relationship to the MAP (again, in mm Hg; lower panel), during bleeding, in a test animal.

MODES FOR CARRYING OUT THE INVENTION

DEFINITIONS AND NOMENCLATURE:

Before the present devices and methods are disclosed and described, it is to be understood that this invention is not limited to sensor designs, measurement techniques, or the like, as such may vary. It is also to be understood that the terminology used herein is for the purpose of describing particular embodiments only and is not intended to be limiting.

It must be noted that, as used in the specification and the appended claims, the singular forms "a," "an" and "the" include plural referents unless the context clearly dictates otherwise.

The term "perfusion failure" as used herein is meant a reduction in blood flow associated with maldistribution of blood through the circulatory system and a reduction in blood flow to a less critical tissue and/or organ relative to blood flow in vital (critical) tissues and organs (*e.g.*, the brain and heart). The term "perfusion failure" is clinically also termed "circulatory shock." In general, "perfusion failure" is meant to encompass reduction in blood flow associated with an increase in PCO_2 significantly above PCO_2 associated with normal perfusion.

The term "measurement" as used herein refers to a single measurement or a series of measurements made over time, and which may be taken continuously or intermittently (*e.g.*, at selected time intervals).

The term "carbon dioxide sensor" is used interchangeably herein with the terms "CO₂ sensor" and "PCO₂" sensor to refer to sensors for measuring the partial pressure of carbon dioxide.

The term "endotracheal intubation" as used herein generally means the insertion of a tube into the trachea through the nose, mouth, or via a tracheostomy (*e.g.*, for the purpose of maintaining an airway or preventing aspiration of food into the airway).

The term "mucosal surface" as used herein refers to a surface of a mucous membrane containing or associated with mucus secreting glands, and which lines body passages, tubular structures, and organs. The mucosal surface of interest herein is the sidewall of a patient's trachea.

The term "adjacent" as used herein (*e.g.*, "adjacent the mucosal surface") means near or against, *e.g.*, at a distance from the mucosal surface that allows acceptably accurate measurement of the partial pressure of carbon dioxide by a PCO₂ sensor. In general, it is preferable that the PCO₂ sensor actually come into contact with the
5 sidewall of the patient's trachea, but it is sufficient that the sensor be "adjacent" thereto as just defined.

The term "patient" as used herein means a mammalian subject, preferably a human subject, that has, is suspected of having, or is or may be susceptible to a condition associated with low blood flow, and thus perfusion failure.

10 The present invention thus provides a method and device for assessing perfusion failure in a patient requiring mechanical ventilation. The invention involves monitoring PCO₂ within the trachea, and/or the rate of change of PCO₂ within the trachea, as high endotracheal PCO₂ values and increasing endotracheal PCO₂ values are associated with perfusion failure, wherein the PCO₂ monitoring is conducted with an endotracheal
15 breathing tube having a PCO₂ sensor incorporated therein or attached thereto.

THE DEVICE AND METHOD OF THE INVENTION:

Fig. 1 illustrates a preferred device of the invention, showing an endotracheal tube represented generally as **10** inserted through the mouth **12** of patient **14**. The tube can, however, be inserted through the patient's nose, or through a tracheostomy. The
20 tube includes a cannula **16** having a proximal end **18** and a distal end **20**, wherein the proximal end is provided with a terminal orifice **22** and a connector **24** for connection to a breathable air supply for introduction of gases to the patient's lungs. The distal end **20** of the cannula is shown placed within trachea **26** of the patient. The endotracheal
25 tube is provided with a sealing means for maintaining an air seal between the cannula and the trachea. Preferably, the tube is a conventional "cuffed" tube having as the sealing means an inflatable cuff shown at **28** in an inflated state as it would be during a surgical procedure. Both the cuff and the cannula are preferably generally constructed of radio-opaque bio-compatible polyvinyl chloride, but as will be appreciated by those
30 skilled in the art other suitable materials may be substituted therefor. The cuff **28** is inflated by introduction of air into cuff inflation line **30** by attachment of a syringe or

the like to the open terminus **32** of the cuff inflation line. The flow of air that is introduced into open terminus **32** of the cuff inflation line **30** is controlled by valve **34**, with inflation of pilot balloon **36** indicating inflation of the cuff. The PCO₂ sensor **38** is shown attached to the exterior of cuff **28** and lying against the inside wall of the patient's trachea, but as will be appreciated by those skilled in the art and as described elsewhere herein, the PCO₂ sensor is not necessarily positioned on cuff **28**. It is merely required that the PCO₂ sensor be incorporated within or attached to endotracheal tube **10** in such a way as to be positioned adjacent to and preferably contact the inner wall of the patient's trachea **26**.

To properly place the device so that PCO₂ measurements can be made within the patient's trachea, the endotracheal tube **10** is inserted into the mouth or nose of the patient, or through a tracheostomy, extended through the pharynx and larynx, and into the trachea **26**. The tube **10** must be sufficiently long so that the proximal end **18** of the cannula and the terminus **32** of the cuff inflation line **30** extend beyond the patient's mouth while the distal end **20** of the cannula is in the patient's trachea **26**. After insertion of the endotracheal tube **10**, the proximal end **18** of the cannula is attached through terminal orifice **22** and connector **24** to a supply of breathable air (not shown). A positive pressure of air in the lungs is maintained by pumping air from the breathable air supply by introduction of air into terminal orifice **22**, through cannula **16** and into the patient's trachea **26** through aperture **40** present at the distal end of the cannula. Prior to introducing air in this way, cuff **28** is inflated by introducing air into the cuff inflation line **30** by a syringe or the like. When the cuff is inflated, the cuff **28** conforms to the natural shape of the trachea while providing a seal with the trachea wall. Inflation of the cuff also forces PCO₂ sensor against the trachea wall, as desired for assessment of perfusion failure using the method of this invention.

In accordance with the present invention, applicants find that a precise assessment of perfusion failure in a patient requiring mechanical ventilation can be obtained by measuring PCO₂ in the trachea using a device as just described. Since carbon dioxide can readily pass through mucosal surfaces, CO₂ generated by metabolic activity occurring in tissue below the mucosal surface that is not carried away by blood flow readily migrates through the mucosal surface. Placement of a PCO₂ sensor

adjacent the interior wall of the trachea thus provides a very good quantification of perfusion failure at all times, including the most critical minutes after the onset of perfusion failure when treatment is likely to be most effective.

As illustrated in Fig. 1, the PCO₂ sensor is operably connected through a
5 flexible cable or catheter **42** to a test instrument **44** including an indicator means that typically indicates the partial pressure of CO₂ in millimeters of mercury (mmHg), which provides an indicia of a degree of perfusion failure.

The CO₂ sensor may be any CO₂ sensor suitable for detection of PCO₂ in the manner described herein. Typical CO₂ sensors used in the examples herein operate by
10 detecting a change in pH in the sensor environment. Specifically, such sensors have a membrane that is permeable to CO₂, and that separates a sodium bicarbonate or carbonic acid (HCO₃) solution from the environment. A pH sensor in the device measures the pH of the sodium bicarbonate solution. Two exemplary CO₂ sensors of this type are manufactured by Microelectrode, Inc. and Nihon Kohden (ISFET PCO₂
15 sensor).

Alternatively, the CO₂ sensor is an optical PCO₂ sensor. Structures, properties, functions, and operational details of fiber optic chemical sensors can be found in U.S. Patent Nos. 4,577,109; 4,785,814; and 4,842,783, as well as in Seitz, "Chemical
Sensors Based on Fiber Optics," *Anal. Chem.* 56(1):16A-34A (1984). Fiber optic
20 sensors for monitoring CO₂ that may be suitable for use in the present invention include, but are not limited to, those described in U.S. Patent Nos. 4,892,383; 4,919,891, 5,006,314; 5,098,659; 5,280,548; and 5,330,718. Other exemplary fiber optic CO₂ sensors are described in Peterson et al. "Fiber Optic Sensors for Biomedical Applications," *Science* 224(4645):123-127 (1984) and Vurek et al. "A Fiber Optic
25 PCO₂ Sensor," *Annals Biomed. Engineer.* 11:499-510 (1983).

A suitable optical CO₂ sensor is described in U.S. Patent No. 5,714,121 ('121) to Alderete et al., (assigned to Optical Sensors Incorporated, Eden Prairie, MN), which pertains to an optical CO₂ sensor and method of manufacture thereof; a preferred sensor system and method of using the aforementioned optical CO₂ sensor is described in U.S.
30 Patent No. 5,672,515 ('515) to Furlong, also assigned to Optical Sensors Incorporated (Eden Prairie, MN). In general, the sensor of the '121 patent is composed of a single optical fiber having a distal tip and a proximal region for communication with a means

for receiving a signal from the distal tip. Light of a predetermined wavelength is directed through the optical fiber towards the distal tip, and emitted fluorescent light returns along the fiber to be detected and converted to a CO₂ concentration value. A capsule, composed of a CO₂-permeable silicone material, is arranged over the distal tip at a predetermined position. The capsule contains an indicator solution having a suitable pH-sensitive indicator component, generally a fluorescent dye, and substantially no air. Examples of fluorescent dyes include without limitation fluorescein, carboxyfluorescein, seminaphthorhodafluor, seminaphthofluorescein, naphthofluorescein, 8-hydroxypyrene 1,3,6-trisulfonic acid, trisodium salt ("HPTS") and dichlorofluorescein, with HPTS particularly preferred. A sealing means provides a liquid-tight seal and affixes the capsule onto the distal tip.

Optical CO₂ sensors are generally used by contacting the distal end of the sensor with a mucosal surface as described herein. Light of a predetermined wavelength is directed from an external source, through the optical fiber, impinging distally on the encapsulated indicator composition. The intensity of the emitted fluorescent light returning along the fiber is directly related to the concentration of CO₂ in the sample, as a result of the pH-sensitive indicator material present at the fiber tip (*i.e.*, the pH of the indicator solution is directly related to CO₂ concentration, as a result of carbonic acid formation). The emitted light is carried by the optical fiber to a device where it is detected and converted electronically to a CO₂ concentration value. The sensor may additionally have a reference dye present in the indicator composition. The intensity of the light emitted from the reference dye may be used to compensate, via ratioing, the signal obtained from the indicator. A more preferred system for determining PCO₂ is described in the '515 patent, directed to a simultaneous dual excitation/single emission fluorescent sensing method, wherein light of two different wavelengths is used to excite a single fluorescent indicator species, with one of the two wavelengths at the isosbestic point. The two fluorescence emission signals that result are ratioed to provide the desired measurement.

The data provided by the CO₂ sensor may be acquired and analyzed by any appropriate means available. For example, Fig. 2 shows data acquisition circuitry that can be used to facilitate CO₂ data analysis. The circuit includes preamplifier **46** and amplifier **48**, which deliver signals representing the CO₂ level to an A/D converter **50**.

The converter output is delivered to a memory **52** which stores the values and delivers them to a CPU, or central processing unit **54**. Software for instructing the CPU to operate on the data, is contained in a memory disk **56**. Pertinent information such as characteristics of the patient can be inputted through a keyboard **58**. CO₂ levels are delivered to the CPU at a rate of five samples per second. The CPU uses this data and the elapsed time from a clock **60** to deliver signals indicating the perfusion state of the patient. Alternatively, the signals displayed may simply indicate the PCO₂ value, from which one skilled in the art can evaluate the degree of perfusion failure. When the signals represent the output of a CO₂ data analysis program, and thus the degree of perfusion failure, various types of indicator means can be used. For example, if the patient's condition is poor, a red light **62** may be illuminated, if the patient's condition is stable a green light **64** may be illuminated, and if the patient's condition is guarded a yellow light **66** may be illuminated. This simplistic output is useful for moderately skilled persons such as medics in the armed forces and paramedics on ambulances. An indication of the patient's condition enables the health worker to determine whether or not the patient should be rushed to a treatment center and/or whether certain steps should be taken to enhance perfusion such as repeated depression of the chest.

The software that controls the CPU can be programmed to determine which of the three signals (red light, green light or yellow light) should be displayed. In general, a particular high level of carbon dioxide **Z**, as well as a low level of carbon dioxide **Y**, are established. These high and low levels may be, for example, a **Z** value of 80 mm Hg and a **Y** value of 50 mm Hg. In addition, the CPU continually determines the rate of increase or decrease of PCO₂. A rate of PCO₂ increase of more than 20 mmHg/hr. indicates a high degree of perfusion failure, while, in comparison, a rate of PCO₂ increase less than 20 mmHg/hr. connotes a lower degree of perfusion failure. If the PCO₂ level is decreasing, or negative, the patient is viewed as stable.

Patients having a PCO₂ greater than **Z** may be assigned to a first patient category, wherein, if the rate of change of PCO₂ in these first category patients is zero or positive, then the condition of the patient is assessed as being poor and the red light is energized. If PCO₂ is decreasing, then the yellow light is energized to indicate that the patient is in a guarded state. If the initial PCO₂ measurement is between the two

levels **Z** and **Y**, then the patient is assigned to a second patient category. The condition of a second category patient is guarded, and thus the yellow light energized, unless the PCO_2 level is increasing at more than 20 mm Hg/hr., in which case the red light is energized. For a third category patient, the carbon dioxide level is less than **Y**, and the patient is deemed to be in a stable condition. If there is a considerable change in carbon dioxide, *e.g.*, the PCO_2 level increases at a rate of more than 20 mm Hg/hr. or decreases at a certain rate such as 10 mmHg/hr. Where the CO_2 level is less than **Y**, a considerable change in CO_2 level may indicate that the patient suffers from a condition associated with abnormally high blood flow.

10 The correlation of perfusion failure with high endotracheal PCO_2 levels and/or increasing endotracheal PCO_2 levels, as well as the correlation of perfusion recovery and low or decreasing endotracheal PCO_2 levels, were tested in an animal (rat) model that simulates a sudden loss or shedding of blood, such as might be caused by a gunshot wound or other severe wound. Perfusion recovery was simulated by subsequently
15 reperfusing the animal with a blood infusion. The results are shown in graph form in Figs. 3, 4 and 5. As indicated on the aforementioned figures, " P_ECO_2 " represents endotracheal PCO_2 (in mm Hg), " P_GCO_2 " represents gastric wall PCO_2 (in mm Hg), and "MAP" represents the mean arterial pressure (again, in mm Hg). All PCO_2 measurements were made using sensors manufactured by Microelectrode, Inc., as
20 discussed earlier herein.

 At the beginning of the test (time = 0 in the graphs of Figs. 3-5), considerable blood was drawn from an animal that was previously in good health, the blood being drawn within a period of a few minutes. Initially, between approximately 10 and 50 minutes, as may be seen in Figs. 3 and 5, mean arterial pressure ("MAP") dropped
25 rapidly, about 30%. In the subsequent period, from about 50 minutes to about 120 minutes, the mean arterial pressure remained about 40% below normal. After 120 minutes, the mean arterial pressure continued to drop; see Figs. 3 and 5.

 Correspondingly, the partial pressure of carbon dioxide, measured both in the trachea and along the gastric wall, remained stable and ultimately increased significantly as
30 mean arterial pressure continued to drop. These data show that an increase in PCO_2 , whether measured in the trachea or along the gastric wall, is inversely correlated with mean arterial pressure during perfusion failure.

The results in the animal model can be extrapolated to represent a human subject suffering perfusion failure. The present invention takes advantage of these phenomena to provide methods and devices to assist a physician or other health care provider in the diagnosis and treatment of a patient having or susceptible to a condition associated with perfusion failure.

For example, although assistance from a paramedic or other person may be available shortly after the initial primary insult, it may take thirty minutes or more for the patient to reach a hospital. During that time, i.e., during transport, the patient may be intubated, and the method and apparatus for measuring PCO_2 according to the present invention allows the physician or other healthcare provider to readily detect the level of PCO_2 relative to normal, as well as the rate of change of PCO_2 . A rapid increase in PCO_2 suggests that the patient has suffered a loss of blood within the last hour or so, while a high level of PCO_2 indicates the patient presently suffers from a low level of aortic pressure and perfusion failure. In this manner the invention can be used to assess the patient's condition, allowing for appropriate and rapid selection of an appropriate therapy.

Thus, the invention provides a method and device for assessing perfusion failure in patients requiring mechanical ventilation in the form of an endotracheal breathing tube. The method may be performed rapidly, with minimal equipment other than that required for the mechanical ventilation system. The invention is useful in a variety of contexts in which a patient requires mechanical ventilation, e.g., patients who have suffered respiratory failure, patients undergoing surgery requiring general anaesthesia, and the like, and wherein ventilation may be effected in one of any number of modes, e.g., assist control mode ventilation ("ACMV"), synchronized intermittent mandatory ventilation ("SIMV"), continuous positive airway pressure ("CPAP"), pressure-control ventilation ("PCV"), pressure-support ventilation ("PSV"), proportional assist ventilation ("PAV"), or the like. The invention is also useful in the treatment and monitoring of newborn infants, as on the order of 1-2% of newborns require some sort of intensive care immediately following birth. For example, premature babies frequently require cardiorespiratory support, while mature babies, also, can suffer from birth asphyxia, sepsis or hypoxia, possibly leading to pulmonary hypertension. Newborns requiring mechanical ventilation in these and other cases will benefit from

the device and method of the invention, in that a rapid and accurate assessment of perfusion failure can be made during mechanical ventilatory support.

5

It is to be understood that while the invention has been described in conjunction with the preferred specific embodiments thereof, that the foregoing description as well as the examples which follow are intended to illustrate and not limit the scope of the invention. Other aspects, advantages and modifications within the scope of the
10 invention will be apparent to those skilled in the art to which the invention pertains.

CLAIMS:

1. A device for assessing the degree of perfusion failure in a patient requiring mechanical ventilatory support, the device comprising:

5 an endotracheal breathing tube comprised of a cannula for carrying air from an air supply pump to the lungs of a patient, the cannula having a proximal end for receiving air from the air supply pump and a distal end having an aperture for releasing air into the patient's trachea; and

10 a carbon dioxide sensor means for detecting the partial pressure of carbon dioxide, the sensor means physically connected to the endotracheal breathing tube in a manner that allows for PCO_2 measurement along the sidewall of the patient's trachea.

2. The device of claim 1, further comprising an indicator means for indicating the detected partial pressure of carbon dioxide in the patient's trachea, the indicator means operably connected to the carbon dioxide sensor.

3. The device of claim 1 or claim 2, wherein the carbon dioxide sensor comprises a fiber optic PCO_2 sensor.

20 4. The device of any one of claims 1, 2 or 3, further including a means for sealing the cannula within the patient's trachea.

5. The device of claim 4, wherein the sealing means comprises an inflatable cuff at the distal end of the cannula.

25

6. The device of claim 5, further including a means for inflating said cuff.

7. The device of claim 5, wherein the carbon dioxide sensor means is affixed to the exterior of the inflatable cuff, whereby upon inflation thereof the sensor means is forcibly positioned against the sidewall of the patient's trachea.

30

8. A device for assessing the degree of perfusion failure in a patient requiring mechanical ventilatory support, comprising:

an endotracheal breathing tube comprised of a cannula for carrying air from an air supply pump to the lungs of a patient, the cannula having a proximal end for receiving air from the air supply pump and a distal end having an aperture for releasing air into the patient's trachea;

an optical carbon dioxide sensor for detecting the partial pressure of carbon dioxide, the sensor physically connected to the endotracheal breathing tube in a manner that allows for PCO_2 measurement along the sidewall of the patient's trachea, wherein the sensor is comprised of an optical fiber means provided with a fluorescent indicator composition;

means for irradiating the indicator composition with light of a predetermined wavelength so as to cause the indicator composition to emit fluorescent light having an intensity proportional to the PCO_2 value in the region surrounding the sensor means;

and

means for converting the intensity of the emitted fluorescent light to a value indicative of PCO_2 .

9. The device of claim 8, wherein the irradiating means is capable of irradiating the indicator composition with light of two different wavelengths, and wherein one of the wavelengths is at the isosbestic point.

10. The device of claim 8 or claim 9, wherein the indicator composition is contained within a capsule arranged over the distal tip of the optical fiber means.

11. A method for assessing the degree of perfusion failure in a patient requiring mechanical ventilatory support, comprising:

(a) providing an endotracheal breathing tube comprised of a cannula for carrying air from an air supply pump to the lungs of the patient, the cannula having a proximal end for receiving air from the air supply pump and a distal end having an aperture for releasing air into the patient's trachea, the endotracheal breathing tube further

including, at the distal end of the cannula, a carbon dioxide sensor means for detecting the partial pressure of carbon dioxide along the sidewall of the patient's trachea;

(b) introducing the distal end of the endotracheal breathing tube into the trachea of the patient so that the carbon dioxide sensor means is positioned against the sidewall thereof; and

(c) detecting the partial pressure of carbon dioxide in the patient's trachea.

12. The method of claim 11, wherein step (c) is repeated so that the rate of change of the partial pressure of carbon dioxide in the patient's trachea can be determined.

13. The method of claim 11 or claim 12, further including (e) determining the degree of perfusion failure in the patient from the rate of change of the detected partial pressure of carbon dioxide in the patient's trachea.

14. The method of claim 11, further including introducing air from an air supply pump through the cannula and into the patient's trachea after step (b) and prior to or during step (c).

15. The method of claim 11, wherein the carbon dioxide sensor means comprises a fiber optic PCO₂ sensor.

16. The method of claim 11, wherein the endotracheal breathing tube further includes a means for sealing the cannula within the patient's trachea.

17. The method of claim 16, wherein the sealing means comprises an inflatable cuff at the distal end of the cannula.

18. The method of claim 14, wherein the endotracheal breathing tube further includes a means for sealing the cannula within the patient's trachea.

19. The method of claim 18, wherein the sealing means comprises an inflatable cuff at the distal end of the cannula.

20. The method of claim 19, further comprising inflating said cuff prior to
5 introduction of air into the patient's lungs.

21. The method of claim 11, wherein the patient requiring mechanical ventilatory support is a surgery patient requiring general anesthesia.

10 22. The method of claim 11, wherein the patient requiring mechanical ventilatory support is a neonate.

23. A method for assessing the degree of perfusion failure in a patient requiring mechanical ventilatory support, comprising:

15 (a) providing an endotracheal breathing tube comprised of a cannula for carrying air from an air supply pump to the lungs of the patient, the cannula having a proximal end for receiving air from the air supply pump and a distal end having an aperture for releasing air into the patient's trachea, the endotracheal breathing tube further including, at the distal end of the cannula, an optical carbon dioxide sensor for detecting
20 the partial pressure of carbon dioxide along the sidewall of the patient's trachea, wherein the sensor is comprised of an optical fiber means provided with a fluorescent indicator composition;

(b) positioning the endotracheal breathing tube so that the optical carbon dioxide sensor contacts the sidewall of the patient's trachea;

25 (c) irradiating the indicator composition with light of a predetermined wavelength so as to cause the indicator composition to emit fluorescent light having an intensity proportional to the PCO_2 value in the region surrounding the sensor means;
and

30 (d) converting the intensity of the emitted fluorescent light to a value indicative of PCO_2 .

24. The method of claim 23, wherein step (c) is repeated so that the rate of change of the partial pressure of carbon dioxide in the patient's trachea can be determined.

5 25. The method of claim 23 or claim 24, further including determining the degree of perfusion failure in the patient from the rate of change of the detected partial pressure of carbon dioxide in the patient's trachea.

10 26. The method of claim 23, further including introducing air from an air supply pump through the cannula and into the patient's trachea after step (b) and prior to or during step (c).

15 27. The method of claim 23, wherein the carbon dioxide sensor means comprises a fiber optic PCO₂ sensor.

 28. The method of claim 23, wherein the patient requiring mechanical ventilatory support is a surgery patient requiring general anesthesia.

20 29. The method of claim 23, wherein the patient requiring mechanical ventilatory support is a neonate.

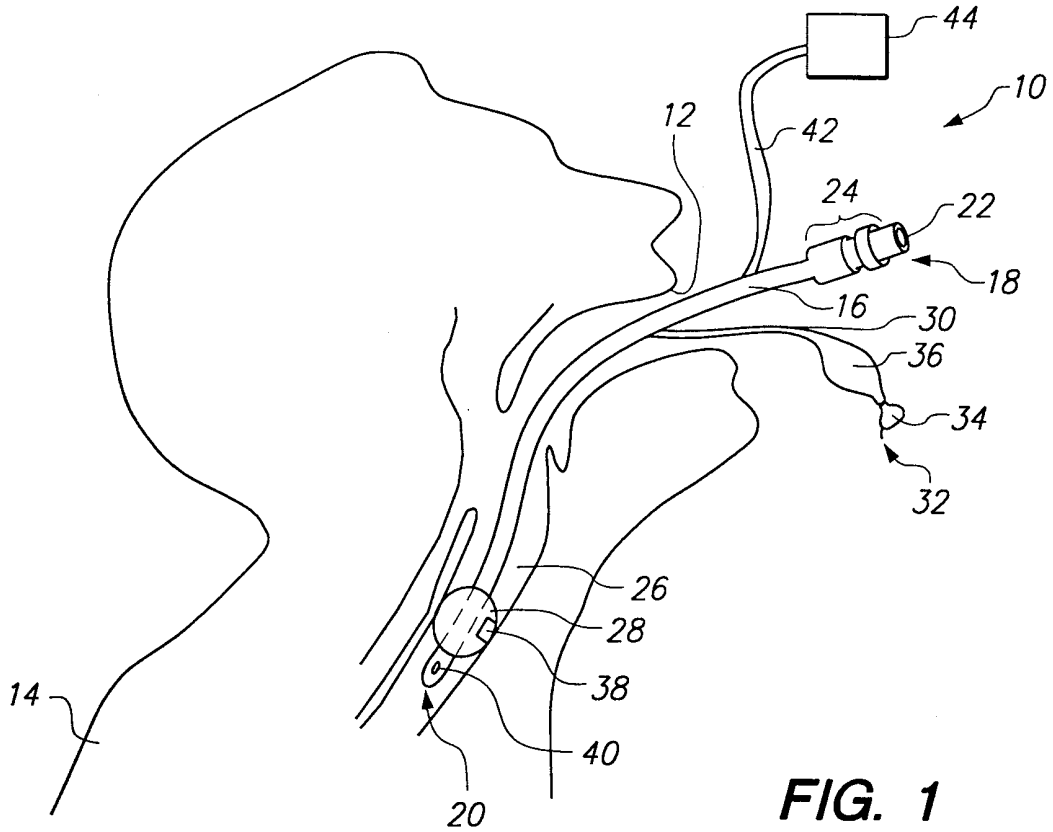

FIG. 1

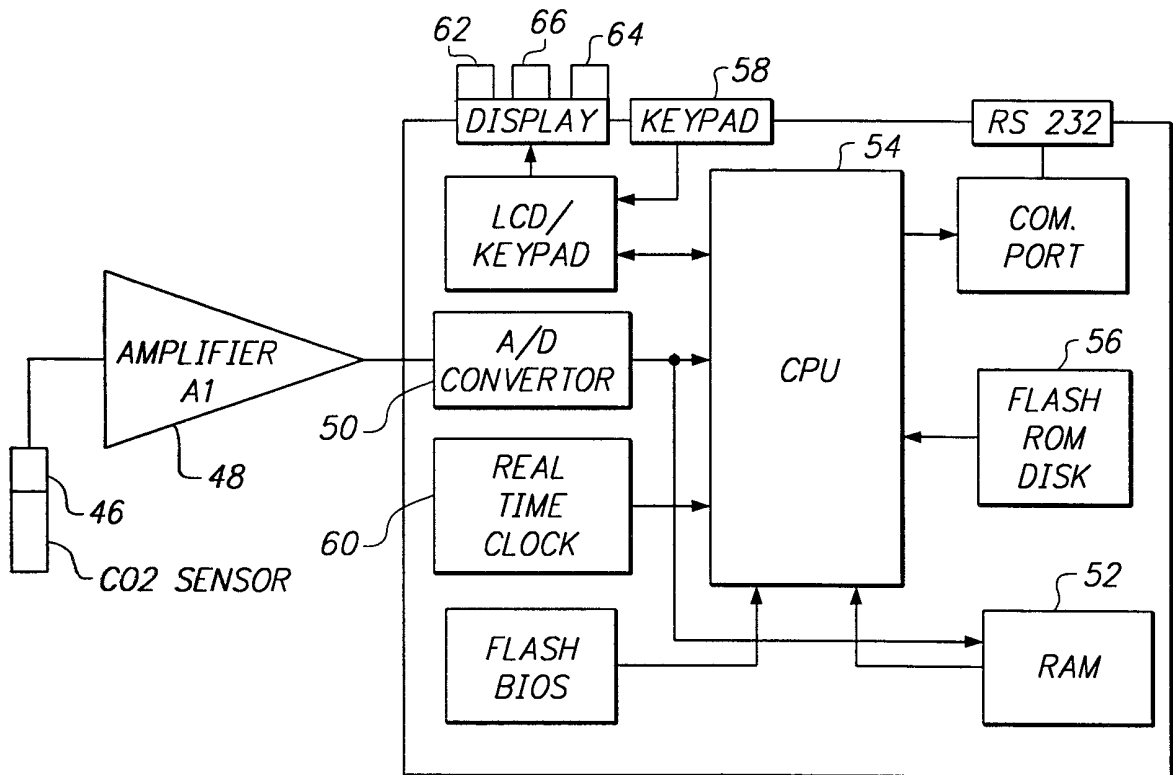
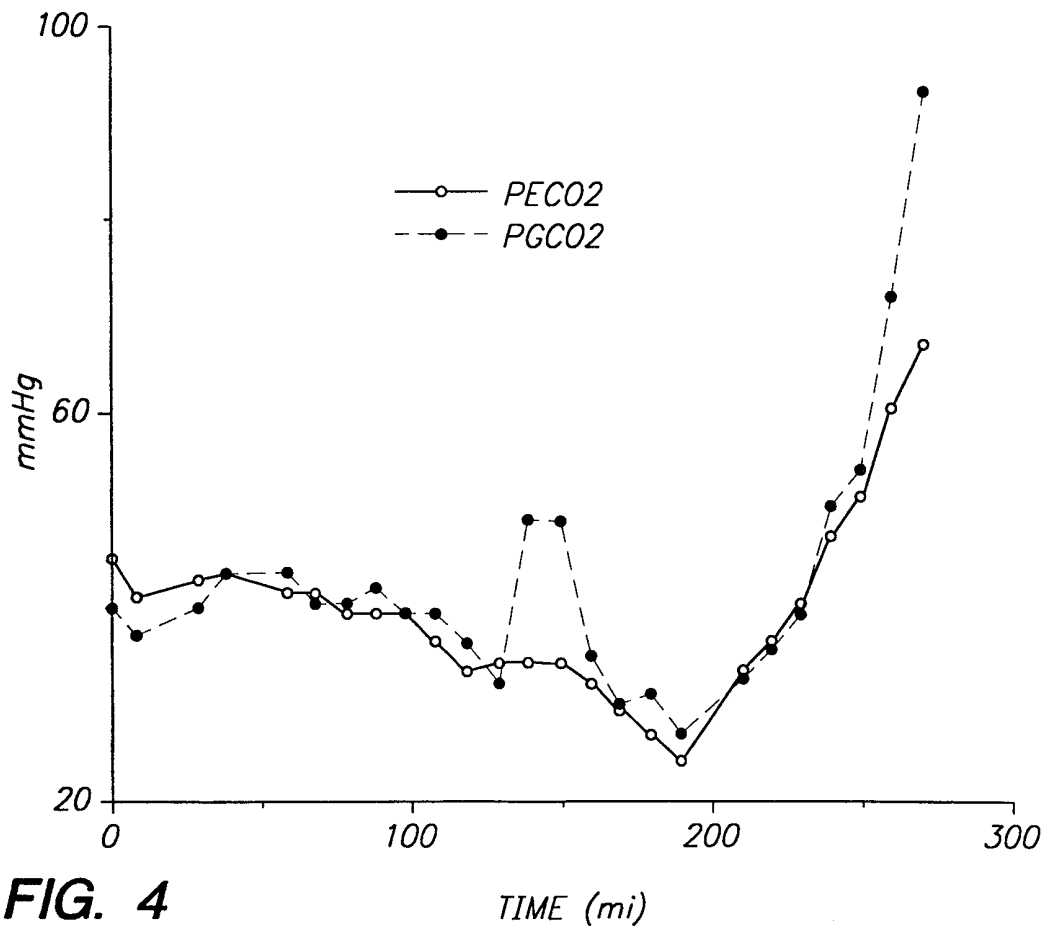
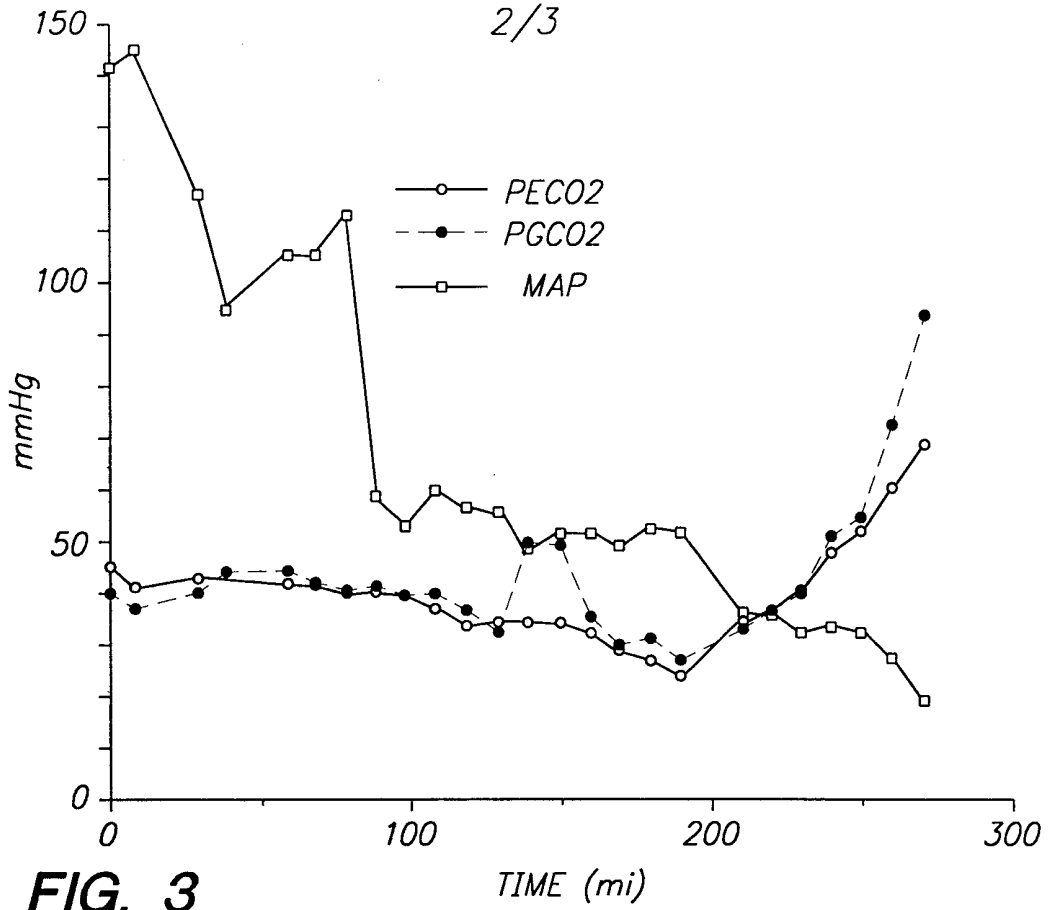

FIG. 2



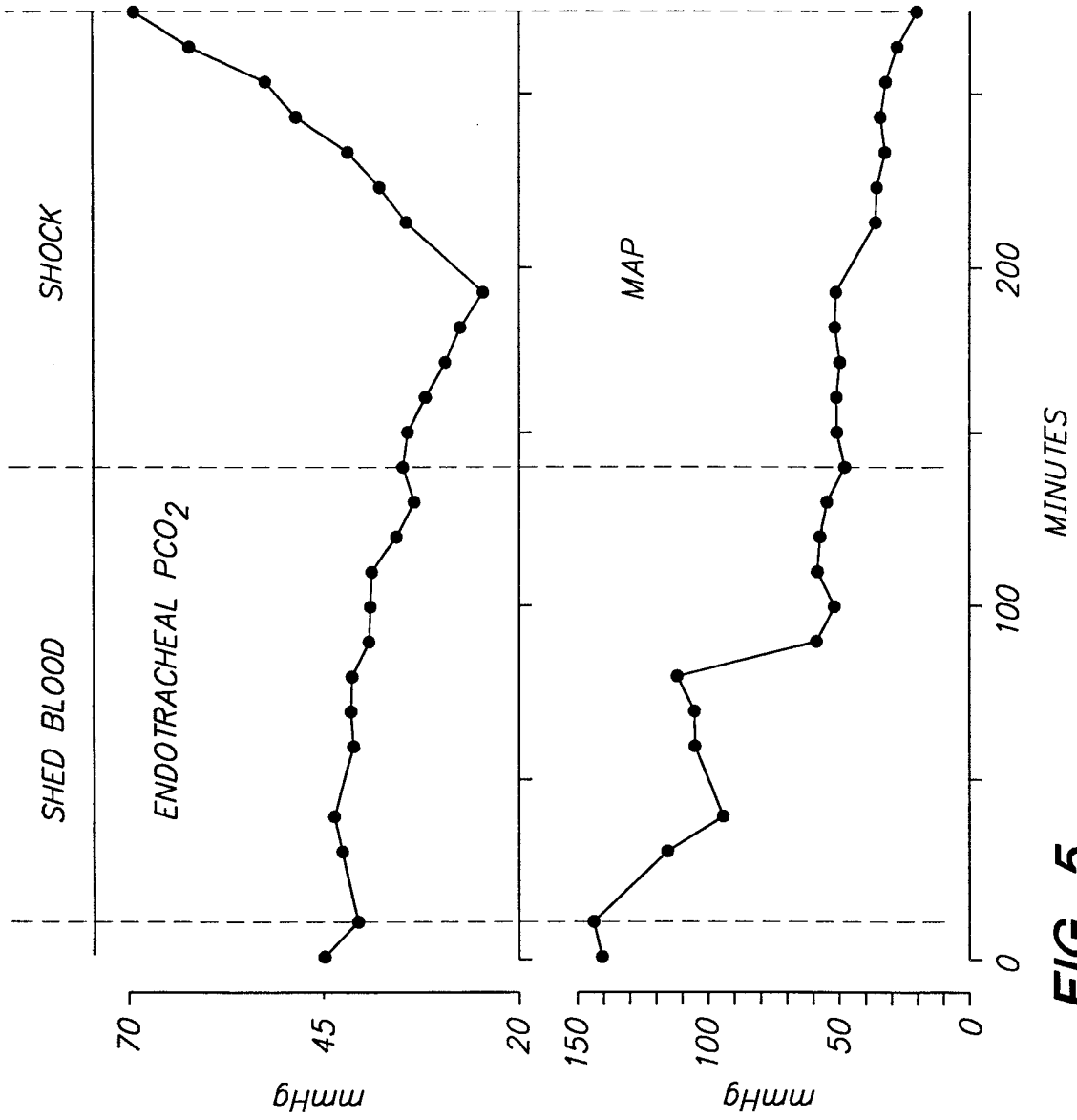

FIG. 5

INTERNATIONAL SEARCH REPORT

International application No.
PCT/US00/04305

A. CLASSIFICATION OF SUBJECT MATTER
 IPC(7) :A61B 5/00; A61M 16/04
 US CL :128/207.14; 600/309, 322
 According to International Patent Classification (IPC) or to both national classification and IPC

B. FIELDS SEARCHED
 Minimum documentation searched (classification system followed by classification symbols)
 U.S. : 128/207.14; 600/309-11, 317, 322

Documentation searched other than minimum documentation to the extent that such documents are included in the fields searched

Electronic data base consulted during the international search (name of data base and, where practicable, search terms used)

C. DOCUMENTS CONSIDERED TO BE RELEVANT

Category*	Citation of document, with indication, where appropriate, of the relevant passages	Relevant to claim No.
A	US 5,005,573 A (BUCHANAN) 09 April 1991, entire document.	1-29
A	US 5,193,544 A (JAFFE) 16 March 1993, entire document.	1-29

Further documents are listed in the continuation of Box C. See patent family annex.

<p>* Special categories of cited documents:</p> <p>"A" document defining the general state of the art which is not considered to be of particular relevance</p> <p>"E" earlier document published on or after the international filing date</p> <p>"L" document which may throw doubts on priority claim(s) or which is cited to establish the publication date of another citation or other special reason (as specified)</p> <p>"O" document referring to an oral disclosure, use, exhibition or other means</p> <p>"P" document published prior to the international filing date but later than the priority date claimed</p>	<p>"T" later document published after the international filing date or priority date and not in conflict with the application but cited to understand the principle or theory underlying the invention</p> <p>"X" document of particular relevance; the claimed invention cannot be considered novel or cannot be considered to involve an inventive step when the document is taken alone</p> <p>"Y" document of particular relevance; the claimed invention cannot be considered to involve an inventive step when the document is combined with one or more other such documents, such combination being obvious to a person skilled in the art</p> <p>"&" document member of the same patent family</p>
--	---

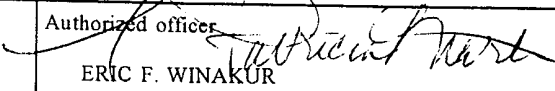
Date of the actual completion of the international search 20 APRIL 2000	Date of mailing of the international search report 08 MAY 2000
Name and mailing address of the ISA/US Commissioner of Patents and Trademarks Box PCT Washington, D.C. 20231 Facsimile No. (703) 305-3230	Authorized officer:  ERIC F. WINAKUR Telephone No. (703) 308-3940