

(19) **DANMARK**

(10) **DK/EP 3554622 T3**



(12) **Oversættelse af
europæisk patentskrift**

Patent- og
Varemærkestyrelsen

-
- (51) Int.Cl.: **A 61 M 39/04 (2006.01)** **A 61 M 39/10 (2006.01)** **A 61 M 39/26 (2006.01)**
- (45) Oversættelsen bekendtgjort den: **2022-10-03**
- (80) Dato for Den Europæiske Patentmyndigheds bekendtgørelse om meddelelse af patentet: **2022-09-28**
- (86) Europæisk ansøgning nr.: **17823226.0**
- (86) Europæisk indleveringsdag: **2017-12-14**
- (87) Den europæiske ansøgnings publiceringsdag: **2019-10-23**
- (86) International ansøgning nr.: **IB2017057944**
- (87) Internationalt publikationsnr.: **WO2018109709**
- (30) Prioritet: **2016-12-15 IT 201600127162**
- (84) Designerede stater: **AL AT BE BG CH CY CZ DE DK EE ES FI FR GB GR HR HU IE IS IT LI LT LU LV MC MK MT NL NO PL PT RO RS SE SI SK SM TR**
- (73) Patenthaver: **Industrie Borla SpA, Via G. Di Vittorio, 7 bis, 10024 Moncalieri (Torino), Italien**
- (72) Opfinder: **GUALA, Gianni, Strada Villa Zanetti 28/18, 10133 Torino, Italien**
- (74) Fuldmægtig i Danmark: **Zacco Denmark A/S, Arne Jacobsens Allé 15, 2300 København S, Danmark**
- (54) Benævnelse: **Y-konnektor til medicinske ledninger**
- (56) Fremdragne publikationer:
DE-A1-102007 020 859
US-A- 4 911 705
US-A1- 2008 086 097
US-A1- 2016 089 529

DESCRIPTION

Field of the invention

[0001] The present invention refers to liquid flow components for medical lines, and more in particular it regards a Y-connector typically used for introducing a secondary flow into the flow of a primary liquid.

State of the prior art

[0002] Y-connectors thus made are for example disclosed by WO-2012/164514 on behalf of the same Applicant, wherein the Y-connector comprises a tubular body having a first inlet coaxial to the tubular body and an outlet, and a second inlet arranged obliquely to the tubular body and communicating therewith between the first inlet and the outlet. The first inlet of the Y-connector is usually sealingly closed by an elastic element, conveniently hollow, having a pre-slot for introducing a secondary liquid into the primary liquid coming from the second inlet.

[0003] The first inlet can be conveniently be formed similar to a female luer lock connector, and in this case the elastic element is configured to serve as a valve: to this end, it has a hollow configuration (for example similar to the one described and illustrated in document US-5,533,708) and axially deformable, following the coupling of the first inlet with a complementary male luer connector, between an extended closing position in which the end thereof exposed towards the external can be easily cleaned and disinfected before coupling with the male connector, and a retracted opening position.

[0004] In use, the axially extended inner cavity of the hollow elastic element can however entail a relatively large secondary liquid stagnation dead area, this being unwanted.

[0005] Document DE 102007020859 discloses a Y-connector corresponding to the preamble of claim 1. Documents US 2008/086097, US 2016/089529 and US 4911705 describe similar connectors.

Summary of the invention

[0006] The object of the invention is to overcome the aforementioned technical drawback and this object is attained due to the fact that the first chamber has a radial size greater than that of the second chamber.

[0007] Thanks to this solution idea the first inlet of the Y-connector according to the invention is thus efficiently protected by the elastic element free of any risk, in use, of liquid stagnation

therein, in that the liquid coming from the second inlet generates continuous replacement thereof.

[0008] The smaller radial size of the second chamber creates - in use - an advantageous effect on the dynamics of the liquid flow in the cavity of the elastic hollow element, in the area for introducing the liquid from the first inlet where greater stagnation could occur. As a matter of fact, the speed of the fluid current is greater in the second chamber with respect to that of the first chamber: thus, the pressure is lower in the second chamber with respect to that of the first chamber. This pressure difference between the two chambers translates into a vacuum in the cavity of the elastic element which, when the secondary liquid is introduced from the first inlet, facilitates the flow thereof basically suctioning it towards the second chamber, thus preventing the creation of areas for the stagnation of the secondary liquid in the cavity of the hollow element more efficiently.

[0009] Furthermore, the arrangement of the radial septum can be such to obtain a swirling flow beneath the elastic element.

Brief description of the drawings

[0010] The invention will now be described in detail with reference to the attached drawings, provided purely by way of non-limiting example, wherein:

- figure 1 is a lateral elevation schematic view of a Y-connector according to the invention,
- figure 2 is a longitudinal sectional view according to line II-II of figure 1,
- figure 3 is a longitudinal sectional view according to line III-III of figure 2, and
- figure 4 is a cross-sectional view according to line IV-IV of figure 2.

Detailed description of the invention

[0011] With reference to the drawings, the Y-connector according to the invention comprises a tubular body 1 having a first inlet 2 and an outlet 3 coaxial to the tubular body 1, and a second inlet formed by a tubular appendage 4 arranged obliquely to the tubular body 1 and communicating therewith between the first inlet 2 and the outlet 3. The second inlet 4 is designated, in use, to be connected to a medical duct of a primary liquid.

[0012] The first inlet 2 is formed similar to a female luer lock connector 5 designated to be coupled with a complementary male luer lock connector for introducing a secondary liquid, and containing a valve device formed by a hollow elastic element 6.

[0013] It should be observed that the elastic element could also be made up of a simple

generally flat cachet.

[0014] The hollow elastic element 6, typically made of elastomeric material, has a distal end 7 normally arranged substantially flushed with respect to the free end of the female luer lock connector 5, and a proximal end 8 that forms a support base axially locked in the body 1. The distal end 7 is formed by a flat wall having a pre-slot 9, and it is easily cleanable and disinfectable ("swabbable").

[0015] The cavity of the hollow elastic element 6, which axially extends between the distal end 7 and the proximal end 8, is indicated with 14.

[0016] The condition represented in the drawings corresponds to the undeformed configuration of the hollow elastic element 6 wherein the first inlet 5 is sealingly closed. Should the male luer lock connector be used with the female luer lock connector 5, the hollow elastic element 6 is deformed and partly compressed ("luer activated") so as to open the pre-slot 9 and thus the communication between the first inlet 2 and the outlet 3.

[0017] According to the invention, the cavity 14 is placed in communication with the second inlet 4 in manner such that, in use, the flow of the primary liquid flowing into the tubular body 1 from such second inlet 4 penetrates into the cavity 14 of the elastic hollow element 6 prior to reaching the outlet 3, thus obtaining an action for washing the inner surface of the wall 7, beneath the pre-slot 9, thus also preventing the stagnation of the secondary liquid in the cavity 14.

[0018] To this end, the tubular body 1 is integrally obtained having an inner septum 10 for deviating the flow coming from the second inlet 4 towards the first inlet 2 and into the cavity 14 of the hollow elastic element 6. Such inner septum 10 extends axially and it is provided with a radial end portion 11 connected to the tubular body 1 in proximity of the base of the second inlet 4 to define a first chamber 12 open towards the hollow elastic element 6 and closed on the side of the outlet 3, and a second chamber 13 open towards the hollow elastic element 6 and towards the outlet 3.

[0019] The inner septum 10 is conveniently offset with respect to the axis of the tubular body 1, so that the first chamber 12 is provided with a radial size greater than that of the second chamber 13. Preferably, and as observable in figure 4, the inner septum 10 is offset twofold, for example in two mutually orthogonal directions as represented in figure 4, in a manner such that the flow coming from the second inlet 4 and deviated towards the first inlet 2 is subjected to a swirling motion, for example generally helical, which improves the effect of washing the elastic element 6 further. The surface of the inner septum 10 facing towards the first chamber 12 can be slightly concave, as equally visible in figure 4.

[0020] There may also be provided further deflectors, not illustrated in the drawings, configured in a manner such to accentuate the swirling motion of the liquid supplied from the second inlet 4 into the cavity 9 of the hollow elastic element 6.

[0021] Obviously, the construction details and the embodiments may widely vary with respect to what has been described and illustrated, without departing from the scope of protection of the present invention as defined in the claims that follow. Thus, as previously mentioned, the invention is equally advantageously applicable in cases where the elastic element of the Y-connector is made up of a flat cachet like in the case of the aforementioned document WO-2012/164514, instead of a hollow element. The liquid deviated from the second inlet 4 towards the first inlet 2 shall perform an efficient action for washing the inner surface of the elastic element in this case too.

REFERENCES CITED IN THE DESCRIPTION

Cited references

This list of references cited by the applicant is for the reader's convenience only. It does not form part of the European patent document. Even though great care has been taken in compiling the references, errors or omissions cannot be excluded and the EPO disclaims all liability in this regard.

Patent documents cited in the description

- [WO2012164514A \[0002\] \[0021\]](#)
- [US5533708A \[0003\]](#)
- [DE102007020859 \[0005\]](#)
- [US2008086097A \[0005\]](#)
- [US2016089529A \[0005\]](#)
- [US4911705A \[0005\]](#)

Patentkrav

5 1. Y-konnektor til medicinske ledninger, omfattende et rørformet legeme (1) med et første indløb (2), der er koaksial med det rørformede legeme (1) og indeholder en ventilindretning, der er dannet af et hult, elastisk element (6), der på tætnende måde lukker det første indløb (2) på en sådan måde, at det kan åbnes, et udløb (3), og et andet indløb (4), der er anbragt på skrå til det rørformede legeme (1) og i forbindelse dermed mellem det første indløb (2) og udløbet (3),

10 hvor det rørformede legeme (1) er udformet med en indre septum (10) til at omlede den strøm, der kommer fra det andet indløb (4) mod det elastiske element (6), inden det dirigeres til udløbet (3), hvor den indre septum (10) strækker sig aksialt og er forsynet med en radial endedel (11), der er forbundet med det rørformede legeme (1) i nærheden af det andet indløb (4) for at definere et
15 første kammer (12), der er åben mod det elastiske element (6) og lukket på siden af udløbet (3), og et andet kammer (13), der er åben mod det elastiske element (6) og mod udløbet (3),

20 **kendetegnet ved, at** den indre septum (10) er forskudt i forhold til akse af det rørformede legeme (1), således at det første kammer (12) har en radial størrelse, der er større end størrelsen af det andet kammer (13).

25 2. Y-konnektor ifølge krav 1, **kendetegnet ved, at** den indre septum (10) er dobbelt forskudt i forhold til akse af det rørformede legeme (1) i indbyrdes vinkelrette retninger på en sådan måde, at den strøm, der kommer fra det andet indløb (4), omledes mod det første indløb (2) med en hvirvlende bevægelse.

30 3. Y-konnektor ifølge krav 1 eller 2, **kendetegnet ved, at** den indre septum (10) er forsynet med en konkav flade, der vender mod det første kammer (12).

DRAWINGS

FIG. 1

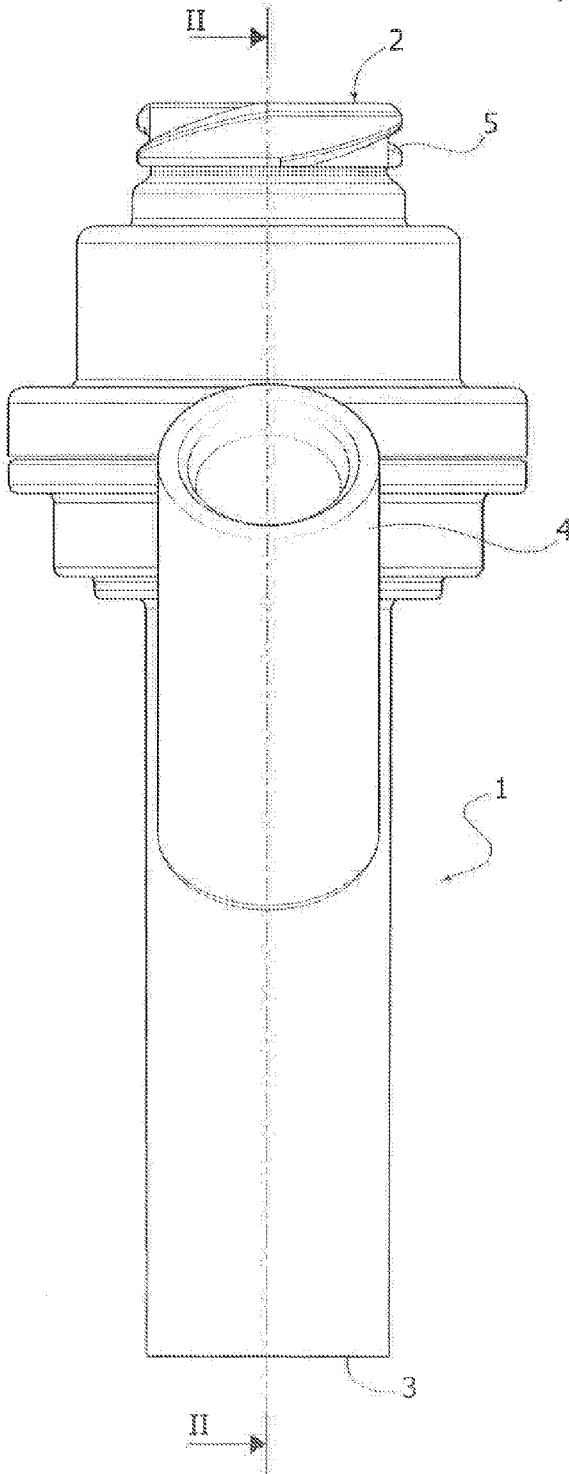

FIG. 2

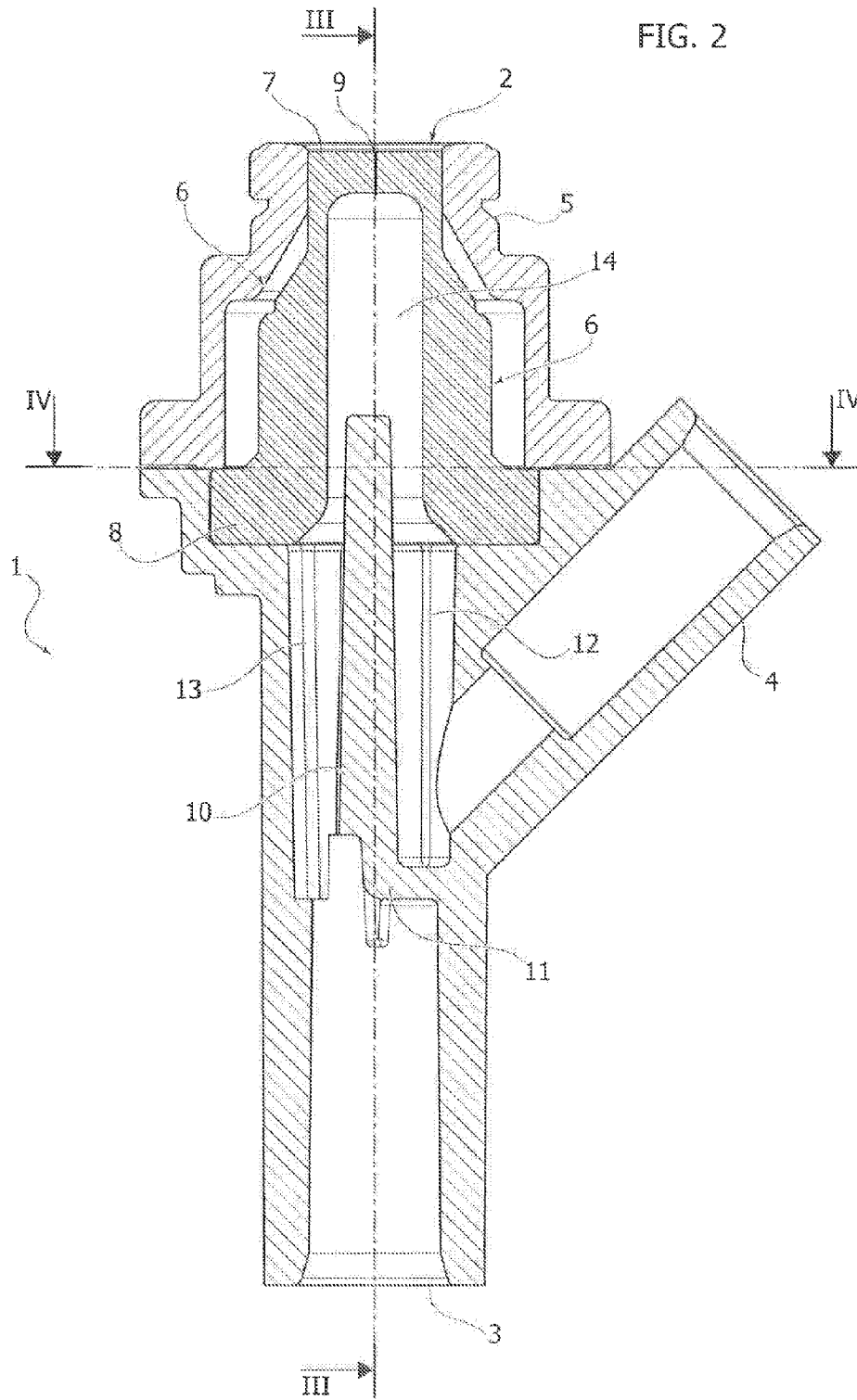

FIG. 3

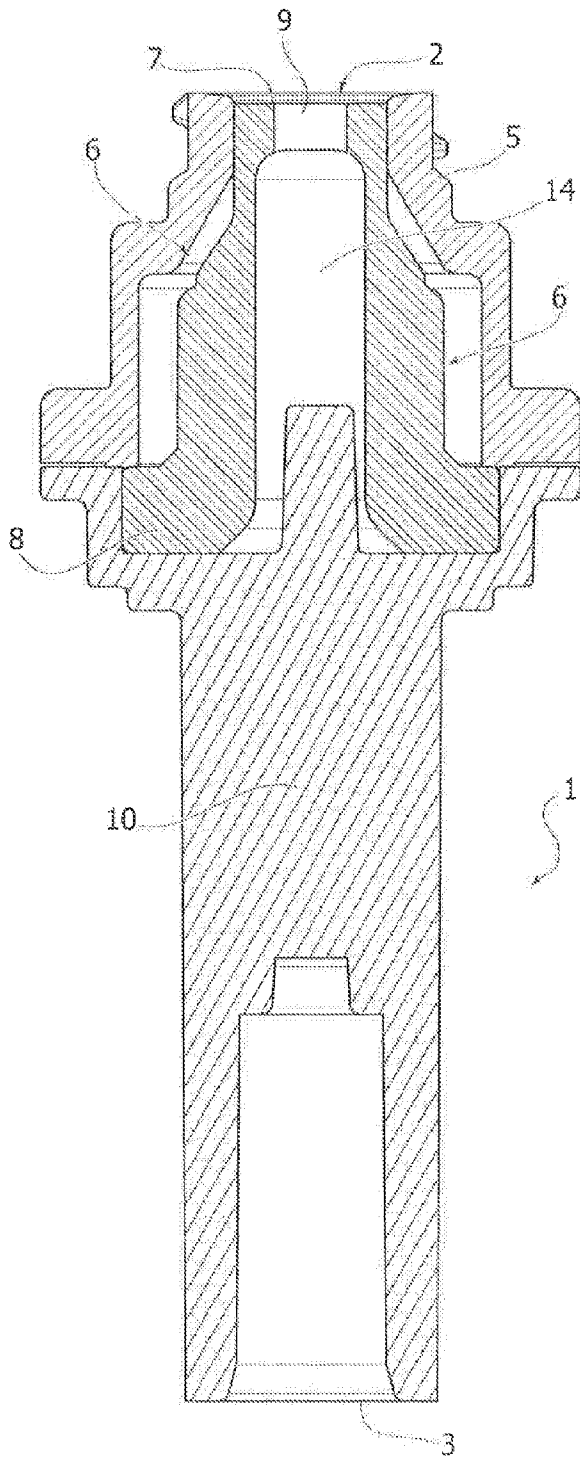

FIG. 4

