

S. H. MITCHELL.  
Wheel Cultivator.

No. 104,334.

Patented June 14, 1870.

Fig. 1.

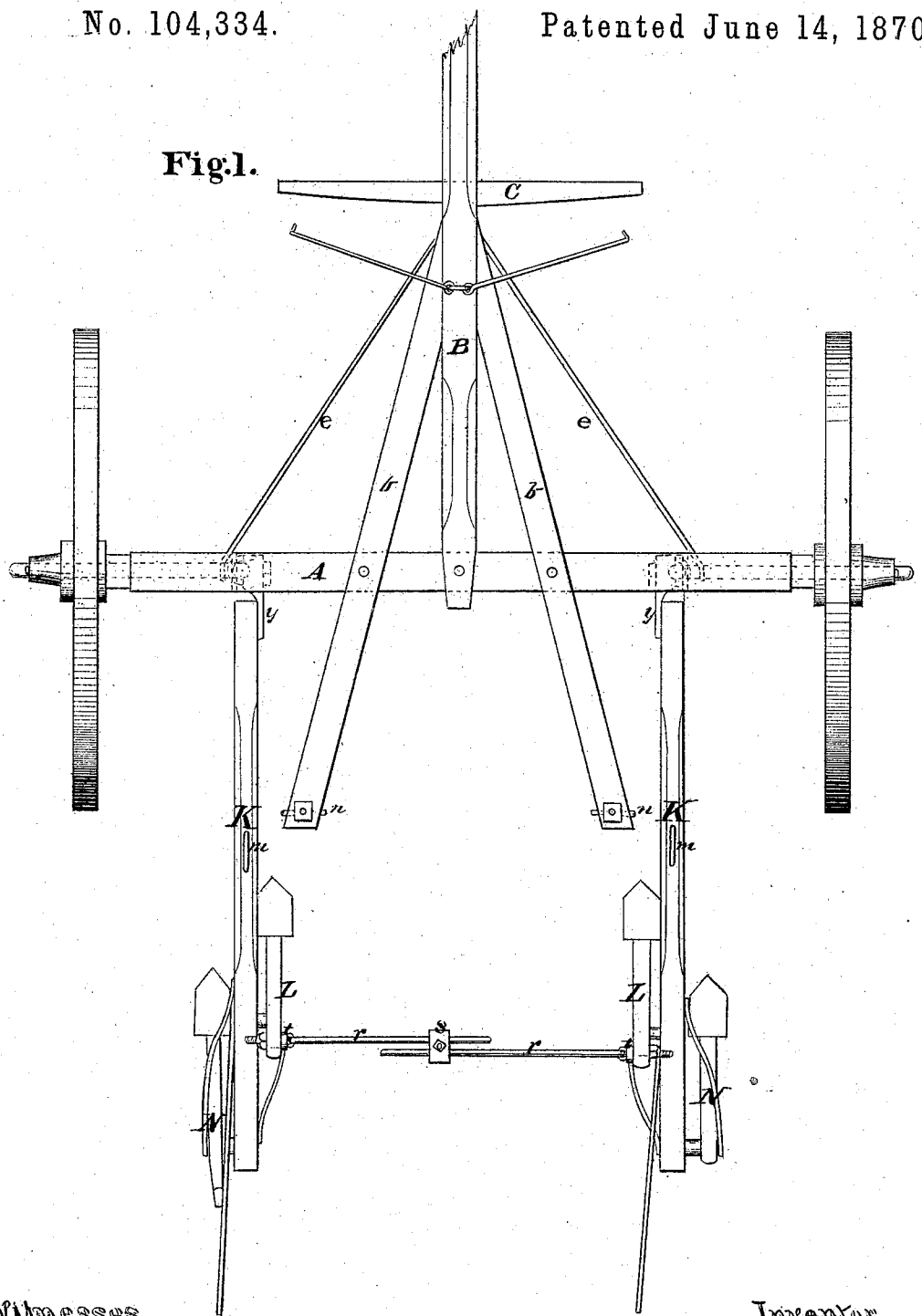

Witnesses  
*E. W. Anderson*  
*H. B. Kane*

Inventor.  
*S. H. Mitchell*  
*Chipman Hosmer & Co*  
 Attorneys

S. H. MITCHELL.  
Wheel Cultivator.

No. 104,334.

Patented June 14, 1870.

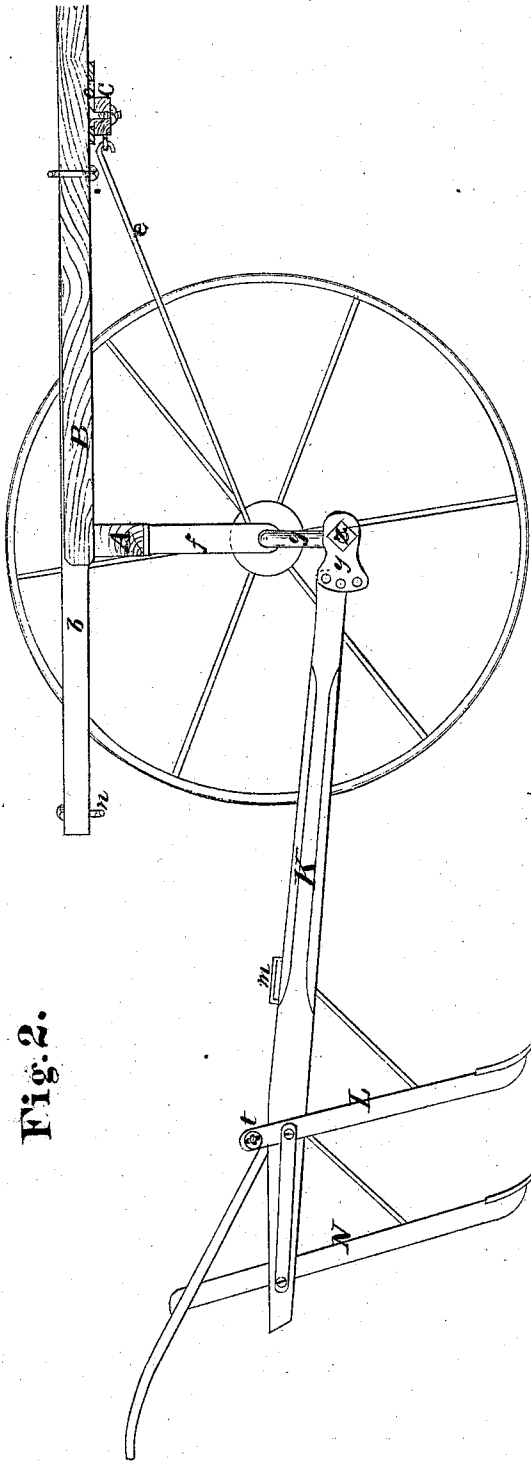

Fig. 2.

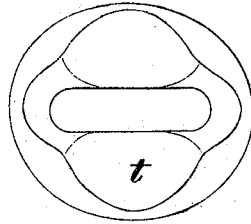

Fig. 5.

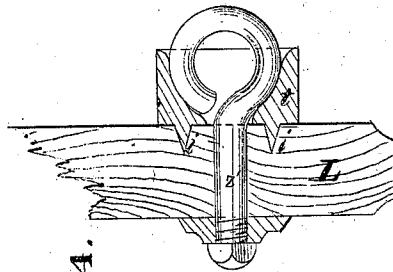

Fig. 4.

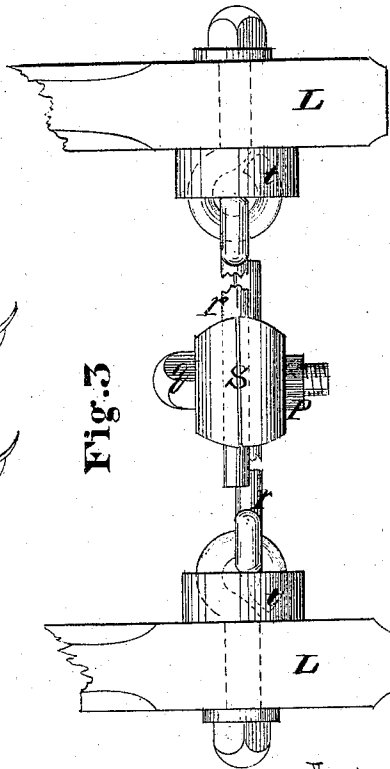

Fig. 3.

Witnesses,  
E. W. Anderson  
D. D. Kane.

Inventor  
S. H. Mitchell,  
Chipman, Hosmer & Co  
Attorneys.

S. H. MITCHELL.  
Wheel Cultivator.

No. 104,334.

Patented June 14, 1870.

Fig. 6.

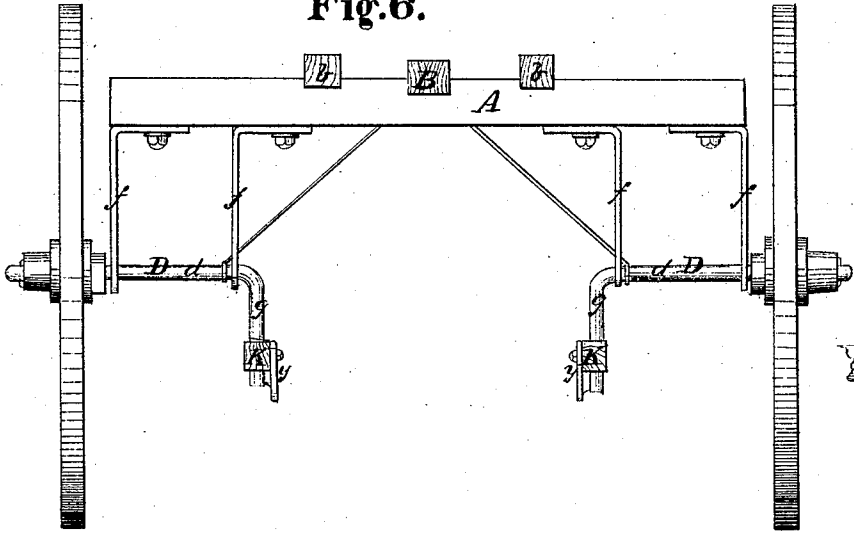

Fig. 8.

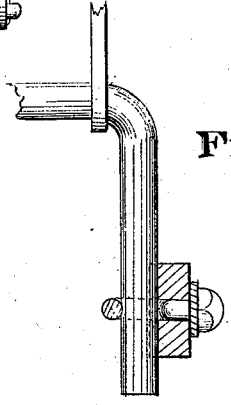

Fig. 7.

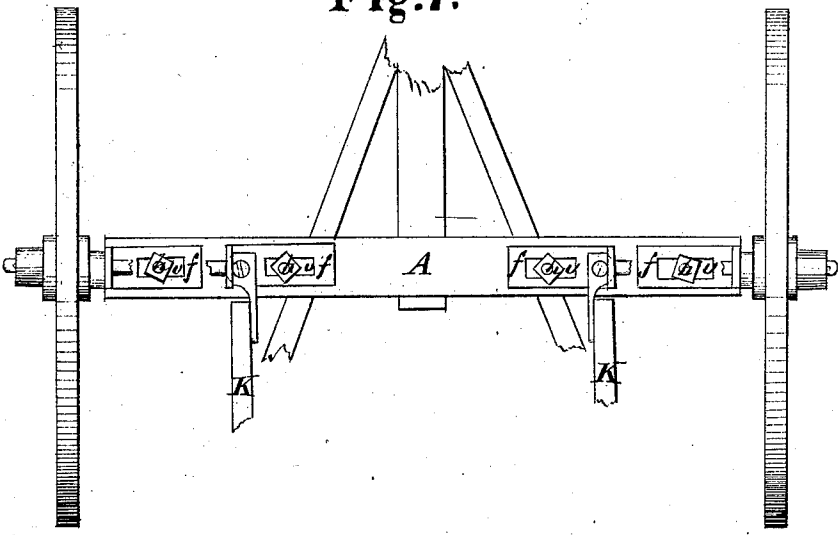

Fig. 9.

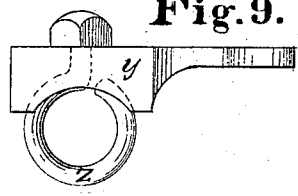
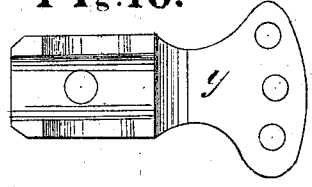

Fig. 10.



Witnesses.  
*E. W. Anderson*  
*A. H. Kane.*

Inventor.  
*S. H. Mitchell.*  
*Chipman, Gosmer & Co*  
*Attorneys*

# UNITED STATES PATENT OFFICE.

SAMUEL H. MITCHELL, OF EL PASO, ILLINOIS.

## IMPROVEMENT IN CULTIVATORS.

Specification forming part of Letters Patent No. 104,334, dated June 14, 1870.

*To all whom it may concern:*

Be it known that I, SAMUEL H. MITCHELL, of El Paso, in the county of Woodford and State of Illinois, have invented a new and valuable Improvement in Cultivators; and I do hereby declare that the following is a full, clear, and exact description of the construction and operation of the same, reference being had to the annexed drawings, making a part of this specification, and to the letters and figures of reference marked thereon.

Figure 1 of the drawings is a top view of my invention. Fig. 2 is a central vertical longitudinal section of the same. Figs. 3, 4, 5, 6, 7, 8, 9, 10 are details of the various parts thereof.

My invention relates to cultivators; and it consists, mainly, in the construction and novel arrangement of devices, whereby the plow-beams are attached to the axles of the wheels and to each other.

The letter A of the drawings designates the body of my cultivator—a strong cross-beam of wood. To the center of this cross-beam is attached the pole B, and this is braced on each side by the bars *b b*, which extend to the rear, and are fitted with the supporting-hooks *n n*.

Under the pole B is secured the plate *c*, which is slotted longitudinally to admit the bolt of the double-tree C. By the use of this plate I avoid cutting a slot entirely through the pole.

A staple is secured to the back of the double-tree, to which are attached the ends of the draft-rods *e e*. These rods extend to the rear and are fastened to the axles DD of the wheels. These axles are bent in such a manner that each is in the form of an elbow, having a horizontal portion, *d*, to which the wheel is attached, and a pendent portion, *g*, to which the end of the plow-beam is fastened. Each axle is connected to the cross-beam A by means of the adjustable standards *f f*, the upper or horizontal portions of which are slotted at *v v* to admit the set-screws *h h*. Thus it is apparent that the wheels may be, within certain limits, adjusted with reference to their distance from each other. The outer standards, *f f*, are provided with guards, which extend over the wheel-hub.

The pendent portion of the axle-bars are attached to the ends of the plow-beams by means

of the ring-bolts *z z* and scalloped adjustable plates *y y*. These plates are arranged with fan-shaped ends, perforated with three or more holes, through which the bolts are passed which secure the plates to the wooden beams. By means of this arrangement the desired angle can be given to the plow-beams with reference to the pendent portions of the axle-bars, which are rigidly connected to the plates *y y*, being prevented from moving by means of the scallops formed in the faces thereof; yet by loosening the nut upon the end of the eyebolt *z* the plate *y* may be adjusted up or down on the pendent rod *g*, thereby raising or lowering the end of the plow-beam. A double adjustment vertically is here obtained.

K K designate the plow-beams, to which are secured the inner plow-standards, L L, and the outer standards, N N. Loops *m m* are secured to the upper faces of the plow-beams, whereby the beams may be raised and supported by means of the hooks *n n*. The plow-beams are attached together by means of the coupling-clamp *s* and rods *r r*, which are attached to ring-bolts fixed in the thimbles *t t* and secured to the heads of the inner plow-standards, L L. When it is desired to alter the distance between the plow-beams, the nut *p*, which, working upon the screw-bolt *g*, tightens the clamp *s*, is loosened. The rods *r r* can now be readily adjusted to produce any desired length between the beams, when a few turns upon the nut *p* will render all tight and secure. The face of each thimble *t t* is excavated, and a slot is formed in the base thereof in the manner shown in the drawings. The object of this formation is to prevent the rods *r r* from turning; and in furtherance of this object the thimbles *t t* are provided with the points or projections *i i*, whereby they are prevented from turning.

The double-tree being attached to the pole by means of the bolt and slotted plate *c*, when the draft-rods *e e* become extended by any means the slack is readily taken up, so that the draft force will always be on the axles.

What I claim as my invention, and desire to secure by Letters Patent, is—

1. In combination with the bent axles DD, herein described, the adjustable scalloped plates *y y* and eyebolts *z z*, whereby the plow-beams are attached in such a manner as to have a double vertical adjustment, as specified.

2. In combination with the clamps *s* and connecting-rods *r r*, the eyebolts *z* and the excavated slotted thimbles *t t*, provided with the spikes or points *i i*, whereby they are prevented from turning on the wood of the plow-beam, as specified.

In testimony that I claim the above I have

hereunto subscribed my name in the presence of two witnesses.

SAMUEL H. MITCHELL.

Witnesses:

J. H. BURTIS, Jr.,  
A. M. CASAN.