

H. P. STRAUB.

Grinding Mill.

No. 53,358.

Patented March 20, 1866.

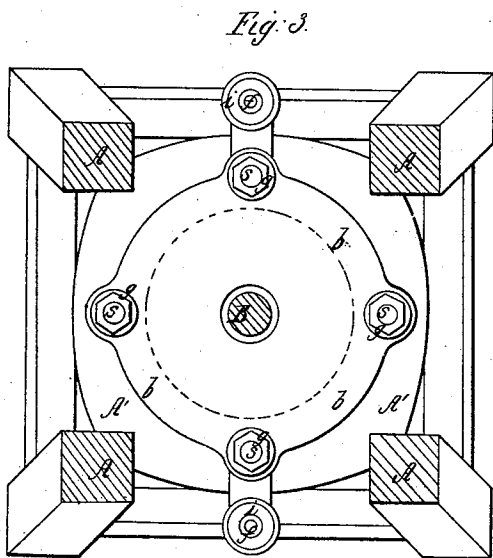
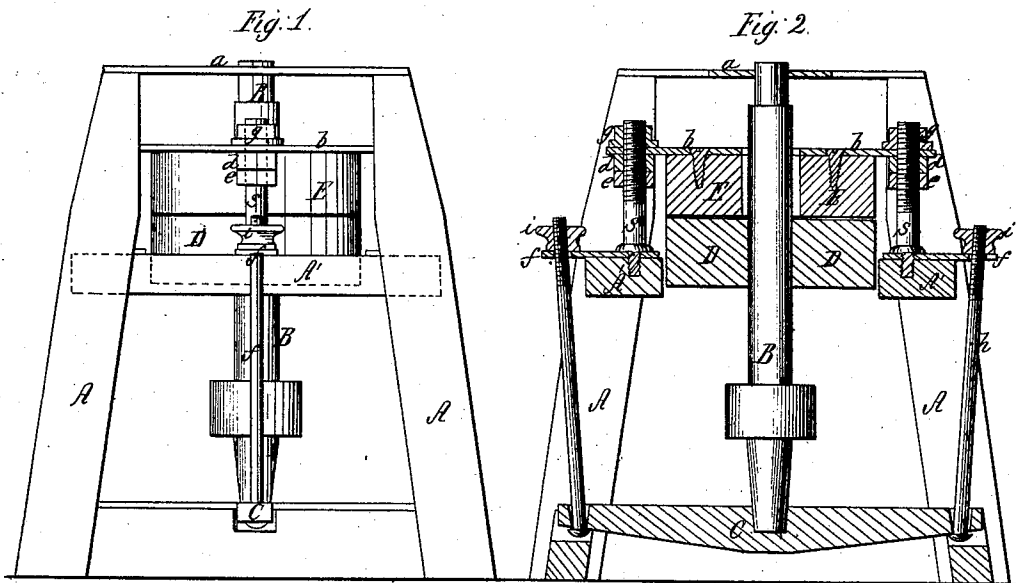

Witnesses:  
T. Campbell  
E. Hafer

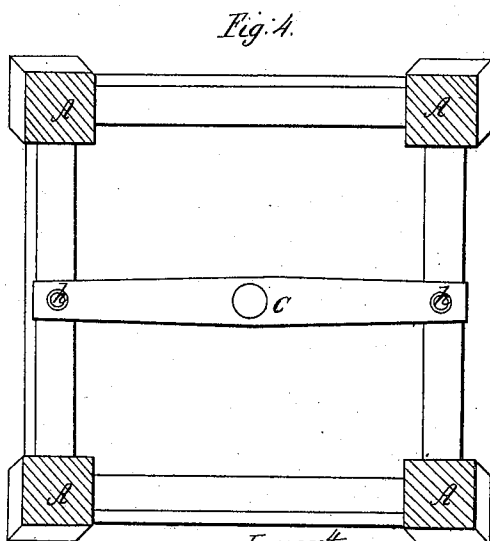

Erventor,  
H. P. Straub  
by his Atty  
Mum. Hirsch & Co.

# UNITED STATES PATENT OFFICE.

H. P. STRAUB, OF CINCINNATI, OHIO.

## IMPROVEMENT IN GRINDING-MILLS.

Specification forming part of Letters Patent No. 53,358, dated March 20, 1866.

*To all whom it may concern:*

Be it known that I, H. P. STRAUB, of Cincinnati, in the county of Hamilton and State of Ohio, have invented a new and useful Improvement in Grinding-Mills; and I do hereby declare that the following is a full, clear, and exact description thereof, reference being had to the accompanying drawings, making a part of this specification, in which—

Figure 1 is an elevation of one side of my improved mill. Fig. 2 is a vertical section through the center of the mill. Fig. 3 is a horizontal section taken through the mill above the upper stone. Fig. 4 is a horizontal section taken below the runner.

Similar letters of reference indicate corresponding parts in the several figures.

This invention and improvement in grinding-mills is intended for trammings or adjusting the grinding-surface of the upper stone parallel to the upper or grinding surface of the runner, so that the two stones can be elevated or depressed bodily and adjusted so that they will run perfectly true with very little attention or experience.

The nature of my invention consists in so combining, in a grinding-mill, a series of nuts and tram-bolts with a bridge-tree which is suspended at both ends that the runner-stone may be adjusted horizontally, then the fixed stone unscrewed or set free so that it may rest squarely against the face of the runner-stone, and while said fixed stone is thus resting against the runner-stone it may be again screwed up or fastened and retained by jam-nuts on a true level with the runner-stone, and after being thus trammed and fastened the runner-stone may be lowered to the proper grinding-position without changing the relative true levels of the two grinding-faces.

It is by combining means which will always enable the miller to adjust the runner-stone to a horizontal plane with means which will always enable him to tram the fixed stone, as above described, that the runner-stone can be used as the support for the fixed stone during the trammings operation, and after being thus used can be lowered so as to work true to the face of said fixed stone. Were it not for the suspension of the bridge-tree at both ends this could not be effected, as every practical miller will see, without a complicated system of mech-

anism, for if the bridge-tree is hung on a pivot at one end the runner-stone, when adjusted with such a bridge-tree, necessarily moves in a circle instead of on a straight line.

To enable others skilled in the art to understand my invention, I will describe its construction and operation.

In the accompanying drawings, A represents the frame of the machine, and A' a shelf, which is secured within this frame at a suitable height.

B is a spindle, which is stepped upon a bridge-tree, C, and which has its upper bearing in a hopper-stool, *a*, extending across the upper ends of the frame A, as shown in Fig. 2.

The running stone D is secured rigidly to the spindle B, so that it will run exactly true, and above this runner is the stationary stone E, through the eye of which the spindle B passes freely. This upper stone is rigidly secured to a cap-plate, *b*, which has four ears projecting from it that are arranged at regular intervals apart. These ears are perforated to receive loosely four standards, *s*, which project up from the shelf A', and which have screw-threads cut on them to receive supporting-nuts *d d d d*, jam-nuts *e e e e*, and binding-nuts *g g g g*, for admitting of the adjustment of this upper stone, and for securing it, when adjusted, rigidly in place to the four posts or standards.

The ends of the bridge-tree C are notched into the sill-pieces of the frame A, and these ends are suspended from projections *f f*, which are rigidly secured to the shelf A by means of screw-rods *h h*, that receive nuts *i i* on their upper ends, as shown in Fig. 2. By means of these nuts and suspension-rods the spindle B, with its runner D, can be elevated or depressed, or adjusted so that the surface of the stone D will be in a horizontal plane.

The operation of my invention is as follows: The holding-down nuts *g* are all loosened and moved upward a suitable distance, so as to allow the upper stone, E, freedom to rise. The lower stone or runner, D, is now elevated, by means of the nuts *i i*, to the desired height and brought in contact with the upper stone, so that this latter will rest squarely upon the surface of the runner. While thus supported the nuts *d* are all moved up snugly against the plate *b*, and the jam-nuts *e* set up tightly against these nuts *d*, so as to hold them firmly

and positively in place. The nuts *g* are now screwed down tightly upon the plate *b* and the upper stone is confined securely in the desired position, after which the runner is lowered the required distance to leave grinding-space between the two stones.

I am aware that it is not new to provide for adjusting the upper stone for leveling it, nor is it new to suspend the bridge-tree at both ends by means of adjustable rods, nor do I claim these features when separately considered.

The main feature of my invention consists in providing for establishing the upper stone in a perfectly parallel position with respect to the lower stone by providing for elevating the bridge-tree support at both ends and thus lifting the upper stone by the lower stone, so that it can be secured while thus supported by

means of jam-nuts acting to hold the supporting-nuts rigidly in place.

Having thus described my invention, what I claim as new, and desire to secure by Letters Patent, is—

1. The combination, in a grinding-mill, of the suspended bridge-tree, nuts *d g*, and the jam-nuts *e* on the tram-bolts *s*, said bridge-tree being suspended at both ends, substantially as and for the purpose described.

2. The arrangement of the tram-bolts *s* and adjusting-nuts *d g*, in combination with the plate *b*, for adjusting the stone *E* perfectly with the horizontal face of stone *D*, substantially as described.

H. P. STRAUB.

Witnesses:

I. I. BROWN,  
HEINRICH APKING.