

E. E. Kilbourn. Spinning Mach.

N: 103,052.

Patented May 17, 1870.

Fig. 1.

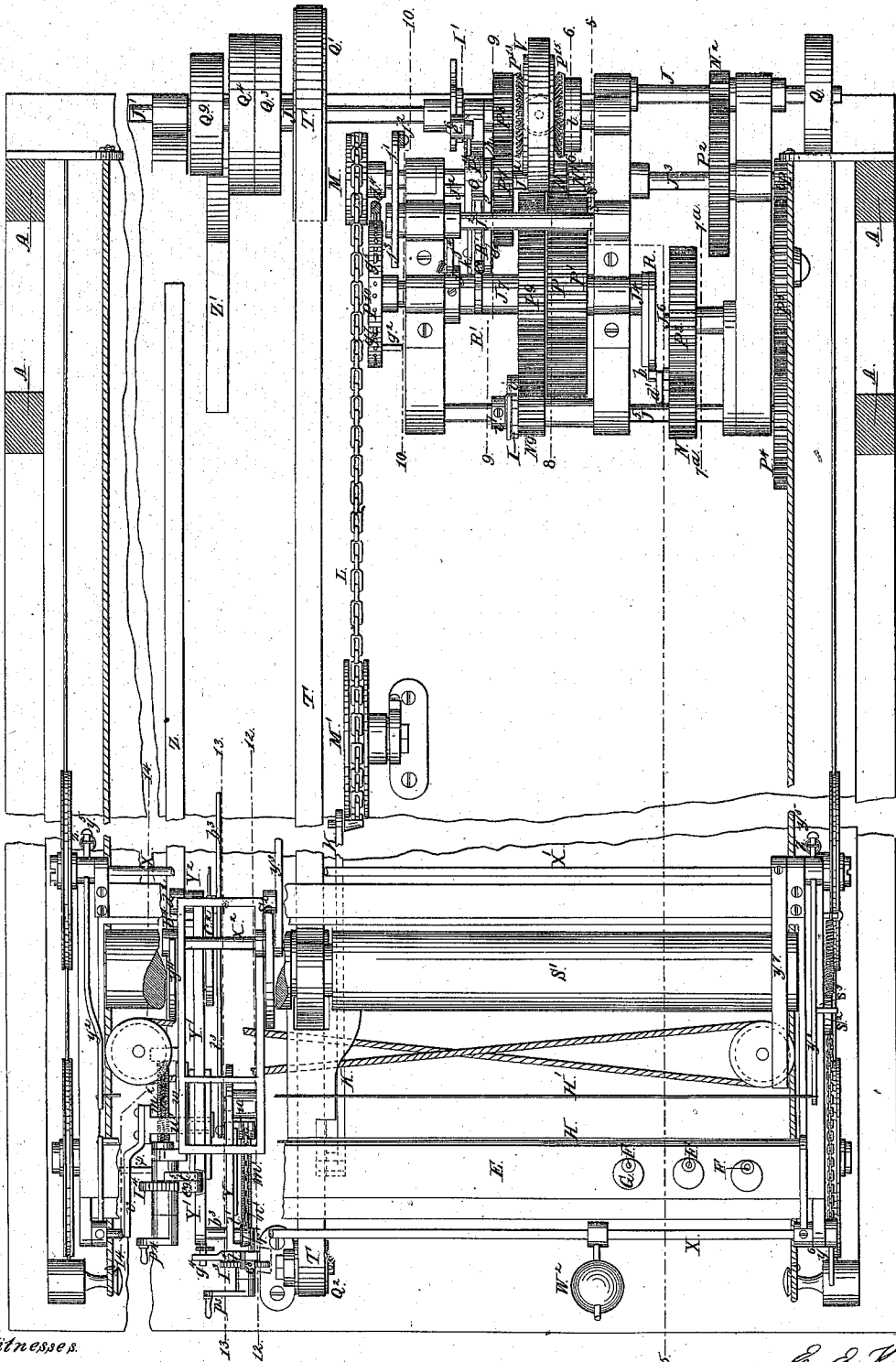

Witnesses:
 John Rathbone, Sr.
 Philip Kelly

Inventor:
 E. E. Kilbourn
 by his atty
 E. S. Kemricky

E. E. Kilbourn.
Spinning Mach.

Sheet 2 - 7 Sheets.

N^o 103,052.

Patented May 17, 1870.

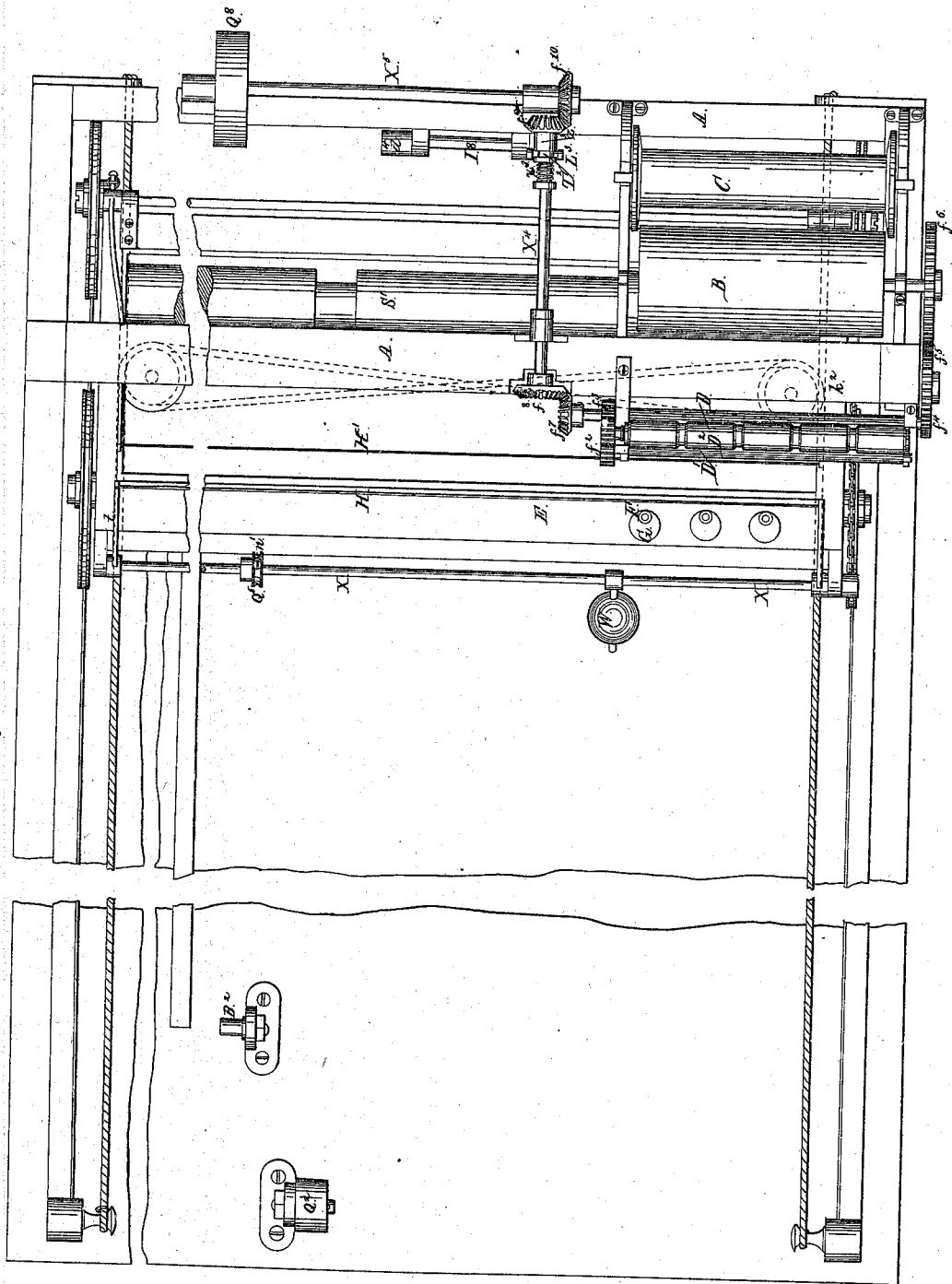

Fig. 2.

Witnesses.
John Rathbone, Sr.
Philip O'Reilly

Inventor.
E. E. Kilbourn
by his att.
C. S. Kenrick

E. E. Kilbourn.
Spinning Mach.

Sheet 4-7 Sheets.

N^o: 103,052.

Patented May 17, 1870.

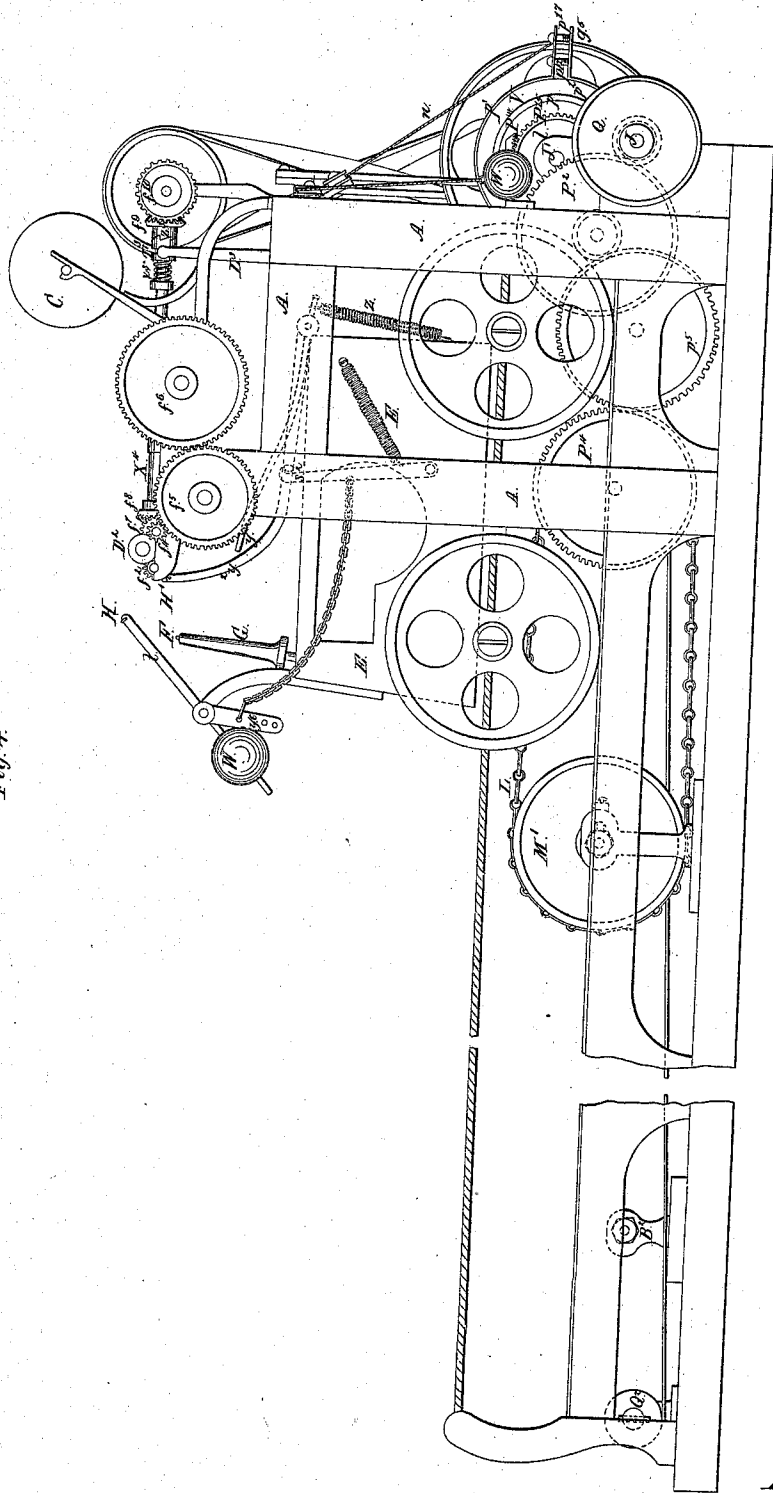

Fig. 4.

Witnesses.

John Rathbone, Jr.
Philip O'Reilly

Inventor.

E. E. Kilbourn
by his atty
E. S. Lemrick

E. E. Kilbourn. Spinning Mach.

Sheet 5-7 Sheets.

N^o 103,052.

Patented May 17, 1870.

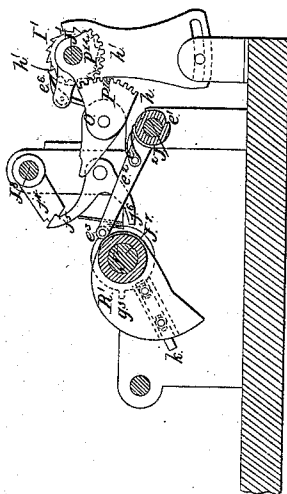
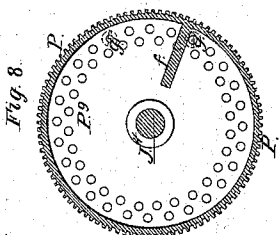
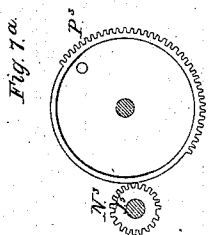
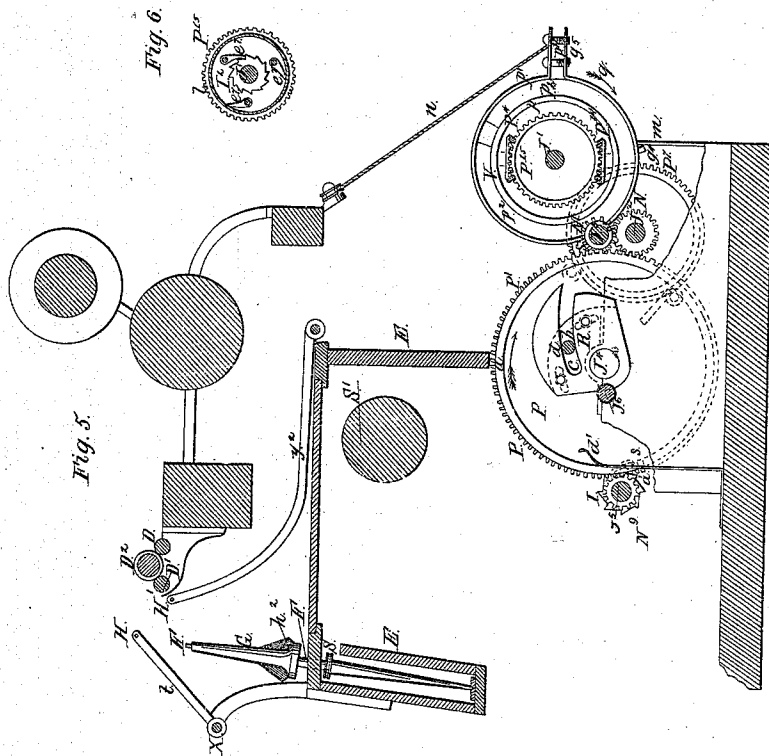

Witnesses.
Oliver Rathbone, Sr
Philip O'Reilly

Inventor.
E. E. Kilbourn
by his atty
E. S. Kemwick

*E. E. Kilbourn.
Spinning Mach.*

Sheet 6 of 7 Sheets.

N^o 103,052.

Patented May 17, 1870.

Fig. 10.

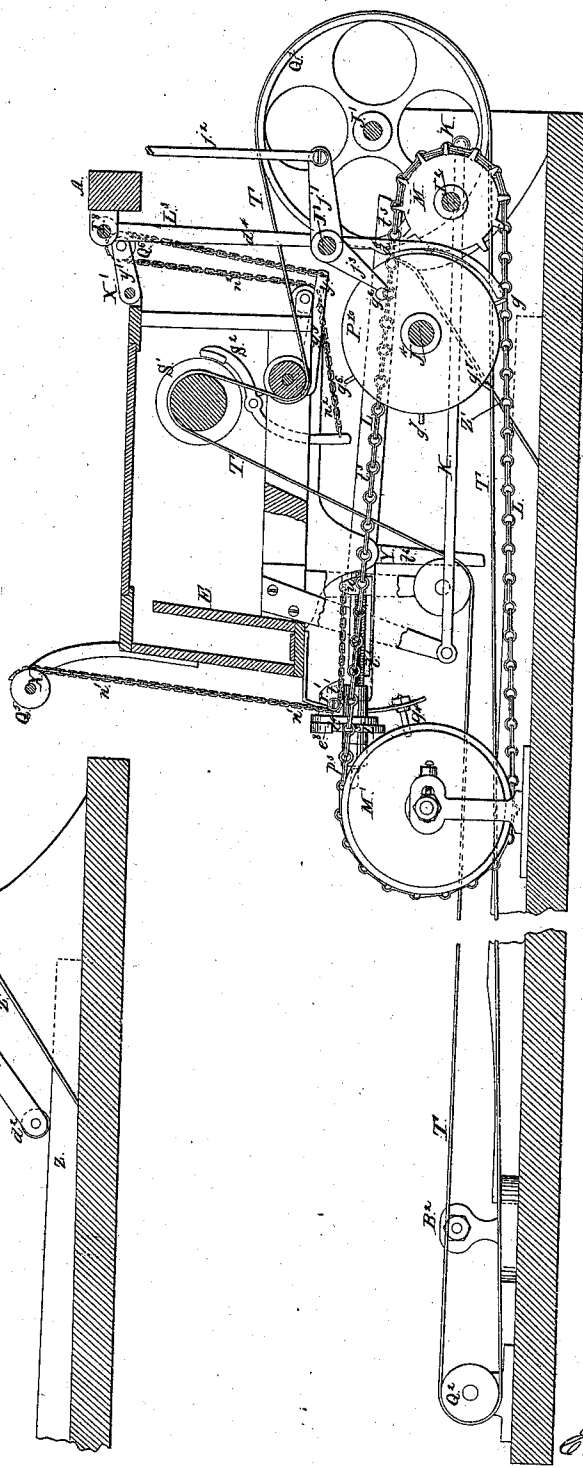
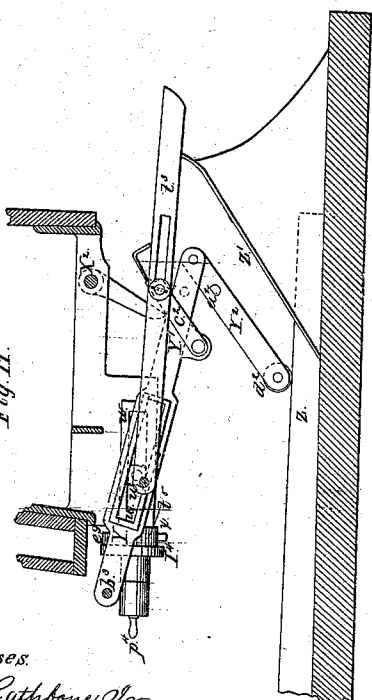

Fig. 11.



*Witnesses:
John Rathbone, Sr.
Philip Kelly*

*Inventor:
E. E. Kilbourn
by his atty
E. S. Kewick*

E. E. Milbourn.
Spinning Mach.

Sheet 7-7 Sheets.

N° 103,052.

Patented May 17, 1870.

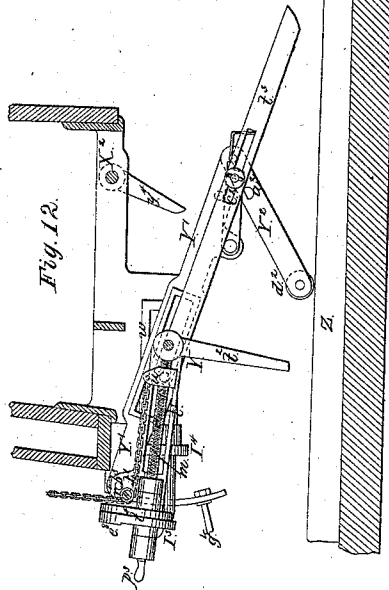
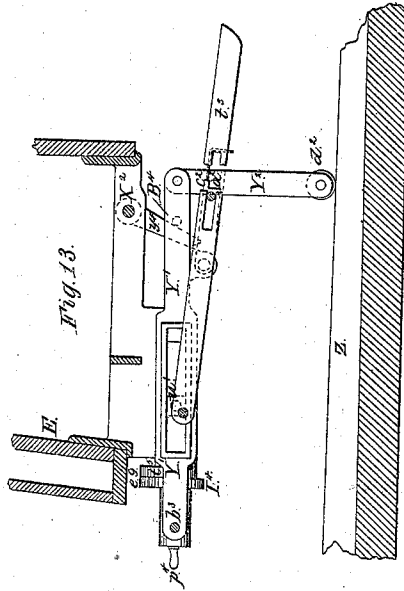
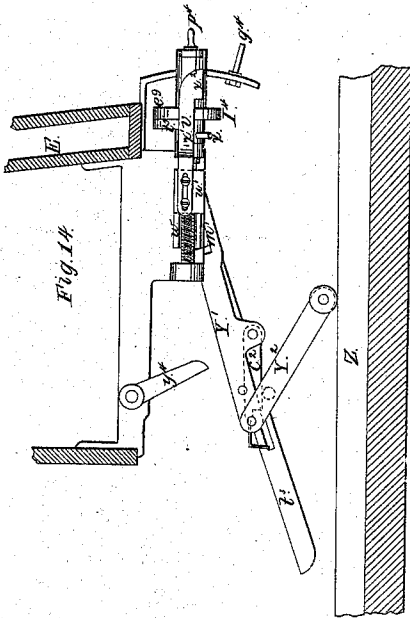

Witnesses.
John Rathbone, Sr.
Philip O'Reilly

Inventor.
E. E. Milbourn
by his atty.
E. S. Kemwick

UNITED STATES PATENT OFFICE.

EDWARD E. KILBOURN, OF NEW BRUNSWICK, NEW JERSEY.

IMPROVEMENT IN MACHINES FOR SPINNING WOOL.

Specification forming part of Letters Patent No. **103,052**, dated May 27, 1870; antedated May 12, 1870.

To all whom it may concern:

Be it known that I, EDWARD E. KILBOURN, of New Brunswick, in the county of Middlesex and State of New Jersey, have invented certain new and useful Improvements in Machines for Spinning Wool, the said improvements being applicable also to machines for spinning cotton; and that the following is a full, clear, and exact description of my invention.

My invention relates to that class of spinning-machines in which rovings are spun into yarns by intermittent drawing, twisting, and winding.

Those machines of this class which are constructed to have the carriage holding the spindles operated by hand are generally known as "jacks;" and such others as have the carriage and its appurtenances operated automatically by power are called either "self-acting jacks" or "self-acting mules." Self-acting jacks, as constructed previous to this invention, are costly machines, and have been brought into use but lately. Consequently there is a very large number of hand-jacks now in use, which are as yet in good working order; and the main object of the invention which constitutes the subject-matter of this patent is to enable such hand-jacks to be transformed into self-acting jacks at a small expense, as compared with the cost of the self-acting jacks or mules thus far introduced.

The improvements about to be described may also be employed with great advantage in the construction of new self-acting jacks, because by their use such new machines can, it is believed, be manufactured at a less cost than those hitherto introduced.

The improvements constituting the invention consist of certain combinations of mechanical instrumentalities, by which combinations the various operations required in jack-spinning can be performed automatically.

The objects accomplished by the use of these various combinations are as follows, viz: First, the movement of the carriage for the spindles at a uniform speed during the delivery of rovings and during the winding of the yarns, and the automatic stopping of said movement; second, the movement of the spindle-carriage, during the stretching of the rovings, with a speed which is progressively reduced, and the

automatic starting and stopping of said movement; third, the automatic arrest of the carriage when it has moved a certain distance outward and the rovings have thereby been stretched to the desired extent; fourth, the movement of the spindle-carriage inward during the hard twisting of the yarns, and the automatic starting and stopping of said inward movement; fifth, the automatic placing of the spindle-carriage under the control of the mechanism for moving it during the winding of the yarns; sixth, the variation of the twisting of the yarns, so as to produce yarns of the required hardness; seventh, the automatic turning of the spindles backward for the purpose of backing off or unwinding the yarns extending to their points; eighth, the movement of the spindles at the desired speed during the winding of the yarns, and the starting and arrest of the said movement without interference with the mechanism for turning the spindles backward; ninth, the variation of the speed of the mechanism for driving the spindles during winding; tenth, the readjustment of the winding mechanism to the position it is to occupy during spinning, after it has been moved therefrom during the backward movement of the spindles; eleventh, the automatic distribution of the yarns upon the bobbins during winding; twelfth, the automatic starting and stopping of the mechanism for distributing the yarns upon the bobbins during winding; thirteenth, the automatic shifting of the distribution of the yarns progressively toward the points of the bobbins; fourteenth, the automatic increase of the range of distribution of the yarns in the vicinity of the heads of the bobbins; fifteenth, the automatic stoppage of the increase of the range of distribution of the yarns when the cones of yarn are formed upon the bobbins; sixteenth, the variation of the length of the yarn extending from the cone of yarn on each bobbin to its point, as the bobbin progressively fills with yarn; seventeenth, the automatic variation of the speed of the bobbins during winding, according to the tension of the yarns; eighteenth, the automatic starting and stopping of the operation of the mechanism for varying the speed of the bobbins during winding; nineteenth, the regulation of the tightness with which the yarn is wound upon the bobbins; twentieth, the automatic

liberation of the counter-faller when the faller is brought into action; twenty-first, the automatic making fast of the counter-faller previous to spinning; twenty-second, the automatic starting and stopping of the mechanism for unwinding or delivering rovings; twenty-third, the automatic delivery and stoppage of delivery of the rovings by the jaws through which they pass to the spindles.

The combinations of instrumentalities which constitute the invention are specified at the close of this specification; and, in order that the construction and operation of these combinations may be fully understood, I will proceed to describe a self-acting jack embodying all the combinations, the said machine being represented in the accompanying drawings, in which—

Figure 1 represents a plan of the machine with the carriage run out. Fig. 2 represents a plan of the machine with the carriage run in. Fig. 3 represents a rear elevation of the machine with the carriage run in. Fig. 4 represents a side elevation of the machine with the carriage run in. Figs. 5 to 14, inclusive, represent transverse sections of the machine, or of parts thereof, at different places, viz: Fig. 5, at the line 5 of Fig. 1, but with carriage run in; Fig. 6, at the line 6 of Fig. 1; Fig. 7^a, at the line 7^a of Fig. 1; Fig. 8, at the line 8 of Fig. 1; Fig. 9, at the line 9 of Fig. 1; Fig. 10, at the line 10 of Fig. 1; Figs. 11 and 13, at the line 13 of Fig. 1; Fig. 12, at the line 12 of Fig. 1; and Fig. 14, at the line 14 of Fig. 1, but looking in the reverse direction to that in which the other sections are viewed.

In the said figures the parts of the machine which are represented are always designated by the same letters; but certain parts of the machine are omitted in each figure, for the purpose of avoiding confusion.

The said machine contains the following essential features of jacks for spinning wool, viz: First, a frame, A, to support the mechanism for delivering the rovings; second, unwinding mechanism, consisting of a series of drums, only one, B, of which is represented, for imparting motion to the spools C, from which the rovings are delivered for spinning; third, jaws, which, in this machine, are roller-jaws, D D¹ D², for delivering the lengths of the rovings to be drawn and twisted at each operation of the carriage; fourth, a carriage, E, with the spindles F, upon which the bobbins G are mounted, the carriage being provided with a faller, H, and counter-faller H', to direct the yarns to the bobbins.

All of these instrumentalities are the same as those of the ordinary hand-jack; and as a representation of the whole of every one of each of these instrumentalities would tend to render the drawings more difficult to be understood, certain portions have been omitted from the drawings.

The operation of these instrumentalities in spinning is the same as with the corresponding instrumentalities in the common hand-

jack—that is to say, assuming that the carriage is at its innermost position, and ready to move outward—

First, the spindles, with the bobbins upon them, are set in rapid motion, and the carriage is moved out for a certain distance with a uniform speed. At the same time the unwinding-drums and the roller-jaws are operated to deliver the lengths of rovings to be spun at one operation.

Second, the delivery of rovings is stopped by the stopping of the revolution of the unwinding-drums and of the roller-jaws, while the carriage continues to move outward (for the purpose of drawing or stretching the rovings) with a speed which progressively decreases.

Third, when the carriage, in its outward motion, arrives at nearly the end of its course, it is moved a short distance inward to compensate for the shortening of the yarns by hard twisting, and this slight inward movement is continued until the twisting is completed, when the motion of the spindles is stopped.

Fourth, the motion of the spindles is immediately resumed, but in a reverse direction, and slowly, for the purpose of unwinding the yarns extending from the cones of yarn on the bobbins to their points, and at the same time the carriage is caused to run outward to the limit of its outward course, so as to keep the yarns in an extended state previous to winding them. This second outward movement is commonly termed "backing off."

Fifth, the spindles are stopped, and are then caused to turn again in a forward direction, and slowly, for the purpose of winding up the yarns. At the same time the faller is depressed to carry down the yarns to the masses of yarn or cones formed on the bobbins, and the faller is moved to guide the yarn, so that it is wound in conical form upon the bobbins. Moreover, while the winding takes place, the carriage is caused to run inward to its first position, and the speed of the spindles during winding is regulated by the tension upon the yarns, so that they are not strained during winding.

The above being the general operation of the machine, a description of the means for performing the several operations automatically, according to the present invention, will now be given.

Power is imparted to the machine by means of two driving-belts, one of which is applied to the belt-pulley of a driving-shaft, J, whose principal office is to transmit motion to the carriage, while the other belt is applied to the belt-pulleys of a second driving-shaft, J', whose principal office is to transmit motion to the spindles. The first improvements relate to the movement of the carriage in the proper directions, at the required times, and with the necessary variations in speed.

In order that the carriage E may be moved, it is connected by a rod, K, with an endless chain, L, which is applied to two wheels, M M'. The first of these wheels, M, is a sprocket-wheel, being fitted with projections, which en-

gage with the links of the chain and compel it to move with it. The other wheel, M' , is grooved to hold the chain, and is set so far from the sprocket-wheel that the distance between the two links of the chain that are farthest apart is equal the length of the course of the carriage. Hence, when that link of the chain with which the carriage is connected is at the outer side of the sprocket-wheel M , as seen in Fig. 10, the carriage is at its innermost position, and is ready to be moved outward. In order that the carriage may be moved at the required times with the proper speeds, the sprocket-wheel shaft J^2 is operated upon successively by four trains of driving mechanism. One of these drives the sprocket-wheel with uniform and rapid speed during the delivery of the rovings and the winding-up of the yarns; the second drives the sprocket-wheel with a progressively-diminishing speed during the stretching or drawing of the rovings; the third causes the carriage to move inward slowly during the hard twisting subsequent to the stretching; and the fourth causes the carriage to move slowly outward during the backing-off movement.

The first of these mechanisms comprises the pinion N on the sprocket-wheel shaft, the main cog-wheel P , the segment-ring of teeth P^1 , extending from a to a^1 on the main cog-wheel P , and the pinion N^1 , which is secured to a counter-shaft, J^3 , that receives motion from one, J , of the two driving-shafts of the jack through the cog-wheel P^2 and pinion N^2 , the last, N^2 , being secured to the driving-shaft J , to which a constantly uniform motion is imparted by a belt applied to the belt-pulley Q . This train of mechanism drives the sprocket-wheel so long as the pinion N^1 gears into the teeth of the segment-ring P^1 . This pinion N^1 runs out of these teeth at the end a , Fig. 5, of the segment about the period when the delivery of rovings is stopped, and consequently then ceases to drive the carriage, and the pinion remains out of gear until the main wheel P has been turned sufficiently by the other trains of mechanism to bring the other end, a^1 , of the segment again into gear with the pinion, which operation takes place when the backing-off movement of the carriage is ended, and the carriage is to run inward during winding.

The second train of driving-mechanism comes into operation as the first ceases to operate upon the sprocket-wheel shaft. This second train consists of the pinion N , the main wheel P , the cam-plate R , secured to the main shaft J^4 , or shaft of the main wheel P , the crank-pin b , segmental wheel P^3 , pinion N^3 , and the train of wheels P^4 P^5 P^6 , which communicate with the counter-shaft J^3 . The crank-pin b engages in the slot c of the cam-plate R , and therefore causes the cam-plate and the main wheel P to turn; but as the crank-pin arbor J^6 and the main shaft J^4 (to which the cam-plate R is secured) are eccentric to each other, the crank-pin in its revolution varies its distance from the main shaft, and consequently the speed

with which the cam-plate and the carriage (moved through its intervention) are caused to move varies during the revolution of the crank-pin, being fastest when the crank-pin is nearest the axis of the cam-plate, and progressively decreasing as the crank-pin gradually diverges from that axis; moreover, as the form of the cam-slot c affects the speed of revolution of the main shaft, the variable speed (imparted by the eccentric action of the crank-pin upon the cam-plate) can be modified as desired by changing the form of the cam-slot. This train continues to act upon the sprocket-wheel shaft J^2 , and to move the carriage until the stretching of the rovings is about completed, which takes place a little before the carriage reaches the outer end of its course. At this time this train ceases to act, by reason of the crank-pin b , in its progressive divergence from the main shaft, disengaging itself from the cam-slot c , shortly after which the pinion N^3 runs out of gear with the segment P^3 , and the latter is then disengaged from the counter-shaft J^3 . The crank-pin then remains at rest until the cam-plate R is turned sufficiently, by the revolution of the main shaft J^4 by the other trains of mechanism, to cause the hinder side, d , of the cam-slot to bear against and turn the crank-pin, thereby moving round the segment-wheel P^3 , so as to bring its teeth into gear with its pinion N^3 just as the pinion N^1 of the first train of mechanism is about running out of gear.

In order to hold the crank-pin b and the segment-wheel P^3 in proper positions while the crank-pin is at rest, a spring, d^1 , is arranged to bear upon the crank-pin b just after the pinion N^3 runs out of gear. This spring is of sufficient strength to hold the pin when it is not moved by the driving mechanism, but yields and permits the crank-pin to pass by it when the crank-pin is moved by the action of the rear side of the cam-slot.

When the crank-pin and cam-plate mechanism ceases to act upon the sprocket-wheel shaft, the carriage, which is then moving outward, tends to continue its outward movement under the strain of the belt which drives the spindles. This tendency is prevented, and the outward movement of the carriage is stopped at the required position, by the action of a pawl, e , which, at the time, is caused to engage with a ratchet-tooth, e^1 , Fig. 9, formed upon the hub of a wheel, P^7 , Figs. 1 and 3, that is secured to the sprocket-wheel shaft J^2 . This pawl forms part of the train of mechanism for causing the carriage to move slightly inward during the hard twisting. It is pivoted to an arm, e^2 , Fig. 9, which is constructed to vibrate freely upon the sprocket-wheel shaft J^2 . The end of this pawl-arm projects toward the main shaft J^4 , and is provided with a projection, e^3 , which is operated upon by a cam, R' , Figs. 1 and 9. This cam is secured to a tubular shaft, J^7 , which is constructed to turn freely upon the main shaft J^4 , and is also fitted with a cog-wheel, P^8 , which is arranged at the

side of the main wheel P, and which, for distinction, will hereafter be called the "sister-wheel."

This sister-wheel is carried around with the main wheel in its revolution by means of a radial projection, *f*, Fig. 8, which is secured to the main wheel, and operates upon a pin, *g*, projecting from the adjacent side of the sister-wheel; and the pin is set in such relation to the cam R' that when, during the operation of the machine, the pinion N³ runs out of gear with the segment-wheel P³, and the crank-pin *b* ceases to transmit motion to the main wheel through the cam-plate R and the main shaft J⁴, the cam R' has just placed the pawl *e* in the tooth of the hub of the wheel P⁷, and stops the further outward movement of the carriage. In order that the carriage may thereupon be immediately moved inward, (so as to permit the yarns to shorten up as they are twisted,) the sister-wheel P⁹ is caused to turn, so as to turn the cam R', thereby moving the pawl-arm *e*², and compelling the pawl to turn the sprocket-wheel M backward. This turning of the sister-wheel is effected by a pinion, N⁹, which is mounted loosely upon the shaft J⁵ and gears into the sister-wheel P⁹. This pinion is connected with the shaft J⁵ by means of a ratchet-wheel, I, and pawl *i*—the former secured to the pinion, and the latter to a hub, *i*', which is made fast to the shaft J⁵.

In the machine represented in the drawings, the shaft J⁵ runs but about one-quarter as fast as the shaft J³, and the difference between the diameters of the pinion N⁹ and sister-wheel P⁹ is greater than that between the diameters of the pinion N³ and the segment-wheel P³. Hence, so long as the main wheel is driven by the pinions N¹ or N³, the sister-wheel P⁹ is carried around by the main wheel faster than it could be turned by the pinion N⁹; consequently the sister-wheel then drives its pinion N⁹ faster than the shaft J⁵ turns, and the ratchet-connection permits the pinion to slip on its shaft. But as soon as the main wheel ceases to be driven by the pinion N³, the pinion N⁹ begins to drive the sister-wheel, and causes the inward movement of the carriage during hard twisting, as before set forth. Hence the pinion N⁹, sister-wheel P⁹, cam R', and pawl *e* constitute the train of mechanism for moving the carriage, through the endless chain, during hard twisting.

In the preceding description it has been stated that the proportions of the parts of the machine represented in the drawings are such that so long as the main wheel P is driven by the pinions N¹ or N³, the sister-wheel P⁹ is carried around by the main wheel faster than it could be turned by the pinion N⁹. It may, however, happen, in spinning some kinds of yarn, that the proportions of the parts of the machine may be varied, so that the main wheel, toward the termination of its movement by the pinion N³, will turn slower than the sister-wheel P⁹ is turned by its pinion N⁹. In such case that pinion N⁹ begins to turn the sister-

wheel before the pinion N³ and crank-pin *b* cease to operate the main wheel P, and the pin *g* will travel away from the radial projection *f*. This premature commencement of movement of the sister-wheel by its pinion might bring the pawl *e* into action too speedily if the pin *g* be not shifted, so as to permit the cam R' to be farther from the arm on which it operates when the pinion N⁹ begins to drive the sister-wheel.

In order that the outward movement of the carriage may be recommenced after the hard twisting is completed, (for the purpose of keeping the spun yarns extended as the spindles are turned backward to back off the yarn extending from the cones of yarn to the points of the bobbins,) a second pin, *g*¹, Fig. 8, is applied to the side of the sister-wheel to operate upon the rear side of the radial projection *f* of the main wheel. This second pin is set in such relative position to the cam R' that said pin comes in contact with the radial projection of the main wheel just after that cam R' has completed its work. Hence the continued movement of the sister-wheel P⁹ by its pinion N⁹ causes the main wheel to move with it by the action of the pin *g*¹ and projection *f*, and the main wheel when so moved operates, through the pinion N, the sprocket-wheel, and the endless chain, to move the spindle-carriage outward during the turning of the spindles backward for the purpose of backing off the yarns.

The continued movement of the main wheel by the sister-wheel carries the first tooth of the segment P¹ into gear with the driving-pinion N¹ at about the time the carriage arrives at its outmost position, so that at that time the said pinion N¹ recommences driving the main wheel and imparting a forward motion through it to the sprocket-wheel M and to the endless chain L, so as to impel the carriage. This recommencement of movement by the main wheel takes place when the carriage is about at the outer end of its course, so that the carriage is then caused to run inward, for the purpose of winding the yarns which have been spun during its outward movement.

As soon as the driving-pinion N¹ begins to operate, the main wheel is driven faster than the sister-wheel could be by its pinion N⁹; hence the radial projection *f* of the main wheel leaves the pin *g*¹, and gradually closes up the space between it and the first pin, *g*, until the said projection comes in contact with said pin, whereupon the sister-wheel is caused by the said projection to move round simultaneously with the main wheel P until the pinion N³ ceases to transmit motion to it, as before described.

In jack and mule spinning it is desirable that the period during which the hard twisting of the yarns is effected should be capable of variation, so that the yarns may be twisted softer or harder, as required.

In the machine represented in the drawings

the place to which the carriage is caused to run inward, by the operation of the pawl e and its connections, is always the same, unless the form of the cam R' be changed, and consequently the position occupied by the carriage at the time hard twisting terminates is not varied.

In order, therefore, that the time during which the hard twisting is effected may be varied, provision is made for stopping the outward movement of the carriage when it has attained a greater or a lesser distance from the roller-jaws, so that the distance which the carriage must be moved, and the space of time required to move it inward from that variable position to the position at which the hard twisting terminates, as above stated, are increased or diminished, and consequently the yarn is twisted for a longer or shorter time and more or less hard. To this end a number of pin-holes is formed in the sister-wheel P^9 , (see Fig. 8,) so that the pin g may be shifted from one to another, to vary the relation which the cam R' bears to the sprocket-wheel shaft J^2 at the time the crank-pin b ceases to transmit motion to the sprocket-wheel shaft, and consequently to vary the position of the pawl e relatively to the tooth e^1 at that time, the pawl being then at a greater distance from the tooth e^1 when the pin g is set farther from the pin g^1 , and the cam R' is less advanced, and the pawl being at a less distance from the tooth e^1 when the pin g is set nearer to the pin g^1 .

The farther the pawl e is from the tooth e^1 at the time the crank-pin b ceases to transmit motion to the sprocket-wheel, the farther will the sprocket-wheel shaft, the sprocket-wheel, and the endless chain be permitted to move before the pawl stops their movement, and consequently the carriage connected with the endless chain will be moved under the strain of the belt which drives the spindles to a greater distance from the fixed point to which it will afterward be moved inward at the time hard twisting terminates, and the twisting will be continued for a longer period. The pawl e is prevented from acting upon the tooth of the hub of the wheel P^7 at an improper time by a guard, h . When the cam R' in its revolution passes by the pawl-arm e^2 the weight of the outer end of that arm causes it to turn downward and draw back the pawl over the guard-plate h , so that the pawl cannot then stop the revolution of the shaft J^2 ; but when the pawl is moved forward by the action of the cam upon its arm, the pawl is permitted to approach the hub of the wheel P^7 by dropping in the notch in the guard h .

As the ratchet-wheel I , the crank-pin b , and the pinion N^1 are all connected by cog-wheels, so that they maintain a fixed relationship to each other, it is expedient, in order that the machine may operate properly, that one or other of two particular teeth of the driving-pinion N^1 shall run into gear with the first tooth of the segment P^1 when that segment is

to begin to work. This result is accomplished by constructing an enlarged tooth, s , upon the side of the segment-teeth P^1 at the point of engagement a , and by constructing two supplementary teeth, s^1 s^1 , upon the hub of the pinion N^1 adjacent to the two particular teeth above referred to, so that one or other of the supplementary teeth of the pinion may engage with the supplementary tooth upon the segment, and thus cause the engagement of the corresponding tooth of the pinion with the first tooth of the segment.

The spindles F , which are mounted upon the carriage E , are driven in a forward direction (or that required for spinning and twisting) in the usual way, by connecting the whirl S , Fig. 5, of each spindle with a long drum, S^1 , by means of an endless cord. The long drum is caused to revolve by means of an endless belt, T , which traverses the drum, and two belt-pulleys, Q^3 Q^4 , the former secured to the floor of the building beyond the outermost position of the carriage, and the latter, Q^4 , secured to the second driving-shaft, J^1 , of the machine. This driving-shaft is fitted with a fast belt-pulley, Q^3 , upon which the driving-belt runs when the shaft is to be driven, and with a loose belt-pulley, Q^4 , to which the driving-belt is transferred when the spindles are not to be turned forward.

In order to transfer the belt automatically from one pulley to the other, as required, during the operation of the machine, a belt-shipper, U , Fig. 3, is provided. A spring, U^1 , also is provided to move the belt-shipper from the fast pulley Q^3 to the loose pulley Q^4 , and to hold the belt upon the latter until the belt-shipper is moved back to the fast pulley.

In order that the belt-shipper may be thus moved it is connected by two arms, j j^1 , Fig. 3, and a rod, j^2 , Figs. 3 and 10, with a rock-shaft, J^8 , and this rock-shaft is provided with a second arm, j^3 , Figs. 1, 3, and 10, which projects within the range of revolution of a pin, g^2 , that projects laterally from the side of wheel P^{10} , which is secured to the shaft J^4 of the main wheel P . This pin is so set relatively to the segment P^1 of the main wheel that the pin g^2 operates upon the arm j^3 , and, moving the belt-shipper, shifts the belt to the fast pulley Q^3 , thus starting the spindles into rapid revolution just as the carriage commences its outward movement. The belt is held in this position until the hard twisting is completed by the engagement of a second arm, j^4 , Figs. 1 and 9, of the rock-shaft J^8 with a spring-catch, j^5 , Fig. 9. This spring-catch j^5 has an arm, j^6 , projecting from its side within the range of a pin, g^3 , (represented in dotted lines in Fig. 9,) that is secured to and revolves with the shaft J^7 of the sister-wheel P^9 , and this arm is so set upon said shaft that it acts upon the arm j^6 of the catch and trips the catch when the hard twisting is completed. The tripping of the catch releases the belt-shipper and permits the spring U^1 to move it, and thereby move the belt to the loose pulley Q^4 ,

whereupon the rapid forward movement of the spindle ceases.

In order that the time at which the belt-shipper is moved by the spring U^1 may be adjusted with facility, the pin g^3 is not secured directly to the shaft J^7 , but is applied to a collar, c^4 , which can be turned upon the said shaft, and is secured thereto by a set-screw.

In order to turn the spindles backward, so as to back off the yarns, the driving-shaft J^1 of the spindles is turned backward by a motion derived from the driving-shaft J , which operates the mechanism for moving the carriage E . For this purpose an arm, k , Figs. 1 and 9, is secured to the shaft J^7 of the sister-wheel P^9 , and is arranged to operate upon the driving-shaft J^1 through the intervention of a lever, O , (which is pivoted to one of the standards of the frame, and is provided at one end with a segment, P^{11}), a vibratable segment, P^{12} , (which is mounted upon the driving-shaft J^1 , and gears into the segment P^{11} of the lever O), a pawl, e^6 , and a ratchet-wheel, I^1 . The ratchet-wheel I^1 is secured to the driving-shaft J^1 , and the pawl is pivoted to an arm projecting from the segment P^{12} . The arrangement of these instrumentalities is such that the revolution of the sister-wheel P^9 by the driving-shaft J , through the intervention of the wheels $N^2 P^2 P^6 P^5 P^4 N^3$, causes the arm k to bear upon the lever O and to move the pawl, so that it operates upon the ratchet-wheel I^1 , and turns the driving-shaft J^1 backward (so as to turn the spindles backward) at the time backing off is required.

The position at which the pawl e^6 is permitted to engage with the ratchet-wheel is determined by a guard-plate, h^1 , which is supported at the side of the ratchet-wheel, and is cut away to permit the pawl to engage at the proper time.

When the arm k passes by the shank of the lever O the backward motion of the spindles ceases, and the preponderating weight of the segment P^{11} (of the lever O) restores the lever and segment P^{12} , with the pawl e^6 , to their first positions. In moving to these positions the pawl e^6 is carried backward over the rim of the guard-plate h^1 , and the point of the pawl is thereby disengaged from the ratchet-wheel I^1 , so that this mechanism for turning the spindles backward does not interfere with the free turning of the ratchet-wheel with the driving-shaft J^1 when the last is driven in the forward direction by the driving-belt.

The spindles are caused to turn forward for the purpose of winding up the yarns, and with the comparatively slow speed then required, by the following means: A cog-wheel, P^7 , is secured to the sprocket-shaft J^2 , and a corresponding cog-wheel, P^8 , is so mounted upon the driving-shaft J^1 of the spindles as to turn loosely thereon. To this second wheel a beveled wheel, P^{13} , is secured, which forms a part of the differential gear $P^{13} P^{14} P^{15}$, the beveled pinions $P^{14} P^{15}$ being pivoted upon arbors carried by the frame V , which is fitted to turn

upon the driving-shaft J^1 , and the hub of the beveled wheel P^{15} being fitted to turn freely upon that driving-shaft. This hub has a ratchet-wheel, I^2 , Fig. 6, secured to it, and this ratchet-wheel is surrounded by a case, l , which is made fast to the driving-shaft J^1 , and contains three pawls, $e^7 e^7 e^7$, Fig. 6, to engage with the teeth of the ratchet-wheel. The operation of this winding mechanism is to turn the driving-shaft J^1 in the proper direction for driving the spindles forward by a motion derived from the main shaft J^4 ; but as this mechanism tends to drive the shaft J^1 at a much slower speed than is imparted to it by the driving-belt which is controlled by the belt-shipper U , the ratchet-wheel I^2 moves round freely within the pawls e^7 so long as the driving-belt is driving the shaft J^1 , to which the ratchet-wheel is secured. When, however, the belt is transferred to the loose pulley Q^1 , the driving-shaft J^1 is left free to be turned by the winding mechanism whenever the sprocket-wheel shaft J^3 is turned.

One object of using the differential gear with the turning gear-frame V is to permit the driving-shaft J^1 to be turned backward during backing off without disarranging the winding mechanism. To this end the turning gear-frame V is permitted to move a regulated extent, and a stop, m , is provided to determine that extent. The turning gear-frame is stopped at the time the spindles are being turned forward for spinning by a pin, g^4 , Fig. 5, which projects from it and comes in contact with the stop m , so that the frame, during spinning, stands as represented in Figs. 3, 4, and 5. The turning of the driving-shaft J^1 backward during backing off causes the pawls e^7 (connected with said shaft by the case l) to operate through the ratchet-wheel I^2 upon wheels $P^{15} P^{14} P^{14}$, and to tend to turn the wheels $P^{13} P^8 P^7$; but as the turning gear-frame V is free to move backward, (in the direction indicated by the arrow q in Fig. 5,) this frame moves and prevents the breakage of the gearing that would otherwise ensue.

The turning of the winding mechanism tends to move the turning gear-frame V in the same direction as it is moved during backing off, and consequently if the turning were not prevented at this time the frame would turn upon the driving-shaft J^1 , and no motion would be imparted to the spindles. In order, therefore, to hold the turning gear-frame stationary during winding, a projection, g^5 , is arranged upon it to come in contact with the stop m at that time, and thus hold the turning gear-frame stationary during winding.

When winding is completed, and the belt-shipper U throws the driving-belt again upon the fast pulley Q^3 , the turning of the driving-shaft J^1 carries the turning gear-frame along with it (in the opposite direction of the arrow q , Fig. 5) until the pin g^4 comes in contact with the stop m , and then the parts of the winding mechanism remain in their normal positions until winding is again to be performed.

In order to insure the return of the turning gear-frame to the position it should occupy during spinning, a weight, W , is provided, and is connected with the frame V through a cord, n , passing over pulleys.

In order to distribute the yarn upon the bobbins during winding, the faller H is operated automatically by the means now to be described.

The faller H is connected by arms $t t$ with a rock-shaft, X , with which a weight, W^2 , is connected, so as to tend to hold the faller in the raised position which it occupies during spinning. The rock-shaft X has a pulley, Q^5 , secured to it, which is connected by a chain, n^1 , with one arm, t^1 , of a bent lever, Y , which is constructed to vibrate upon said carriage. This vibrating arm t^1 is connected by a pin, b^3 , with the outer end of a leg-lever, Y^1 , which is pivoted to the carriage, and is provided at its inner end with a hinged leg, Y^2 . The leg has a lug, a^2 , at one of its sides, and a hooked stop, c^2 , is provided to engage with said lug and hold the leg in an erect position when it is placed therein, and the carriage is moved inward. The lower end of the leg is provided with a wheel, a^2 , which is constructed to run upon a track, Z , that extends beneath the carriage.

While the carriage is running outward, the parts thus described occupy the positions in which they are represented at Fig. 12, the leg Y^2 being then bent; but as the carriage, during the last of the backing-off movement, approaches the outer end of its course, the lower arm, t^2 , of the bent lever Y comes in contact with a stationary stud, B^2 ; and as this arm is thereby arrested, while the carriage continues to move outward, the bent lever is caused to turn on its pivot, its vibrating arm t^1 is depressed to draw the faller H down upon the yarns, the leg-lever Y^1 is rocked upon its pivot, and the leg Y^2 is raised to an erect position, as seen at Fig. 13, in which position it is caught and retained by the hooked stop c^2 . The vibrating arm t^1 and the faller connected with it are thus put under the control of the track Z , upon which the leg Y^2 bears, and the subsequent movement of the carriage inward causes the leg Y^2 to traverse the track Z , which is so inclined as to first cause the leg to depress the faller to the base of the cone of yarn upon each bobbin, and then to permit the ascent of the faller progressively to the point of the cone.

When the carriage arrives at its innermost position the leg Y^2 is released from the hooked stop c^2 , and is permitted to reassume its bent position (thereby permitting the faller to be raised by the weight W^2) by the action of an incline, Z' , upon an arm, t^3 , which is pivoted to the slide n of the bent lever Y , and is connected with the hooked stop c^2 , so that when this stop-arm t^3 is raised by the incline the hooked stop c^2 is thereby disengaged from the lug a^2 of the leg Y^2 .

The yarn formed by each spinning operation must be wound upon the bobbins a little

nearer their points than at the last preceding winding operation.

In order that the movement of the faller may be varied automatically for this purpose the faller-chain n^1 is not secured directly to the vibrating arm t^1 , but is passed partly round a pulley, r^1 , at the end of the arm t^1 , and is fastened to a sliding nut, u , which is traversed by a screw, m^1 , that is secured to and carried by the vibrating arm t^1 . The head of this screw m^1 is fitted with a ratchet-wheel, I^3 , and a pawl, e^3 , for the said ratchet-wheel is pivoted to a bent lever, t^4 , which is constructed to vibrate upon the stem of the screw; moreover, a movable stud, g^4 , is secured to the carriage within the range of vibration of the shank of the said bent lever as it is moved up and down. Hence, whenever the vibrating arm t^1 is depressed the pawl-lever t^4 is turned, and the pawl is caused to act upon the ratchet-wheel and to turn the screw partially, thus shifting the sliding nut u , which is the fastening of the chain n^1 , nearer the pulley r^1 , thereby lengthening the effective length of the chain-connection between the end of the vibrating arm t^1 and the faller, and depressing the faller a less distance at each successive operation.

When, on the other hand, the vibrating arm t^1 is raised, the pawl-lever I^3 is permitted to turn backward by reason of the preponderating weight of its shank, and the pawl is shifted to a new position on the ratchet-wheel.

The head of the shifting-screw m^1 is provided with a crank-handle, p^3 , so that it may be screwed backward by hand to set the faller H in the proper position for operating upon the yarns when an empty set of bobbins is applied to the spindles.

The heads of the bobbins commonly used upon jacks have curved shoulders, as seen at h^2 , Fig. 5. Hence, when the winding of yarn is commenced upon such bobbins the range of vibration of the faller must be small, and the range must be progressively increased, so as to direct the yarns progressively lower and lower upon the bobbins, as well as higher, until the cones of yarn at the heads of the bobbins are properly formed, the yarn on each bobbin being distributed in layers, as indicated in section by the red lines in Fig. 5.

In order that the extent of vibration of the faller may be progressively and automatically increased by the machine represented in the drawings, a means is provided of shifting the pivot of the leg-lever Y^1 progressively toward its inner end, at which the leg is pivoted, so as to vary the ratio of its two arms, and thus increase the vibration of the vibrating arm t^1 , and consequently increase the vibration of the faller, which is moved by that vibrating arm at each successive course of the carriage until the cone of yarn is properly formed at the head of each bobbin. In order to shift the pivot of the leg-lever Y^1 in this manner, it is connected with a slide, w , which is arranged to slide transversely to the length of the carriage in a guide, w , and is traversed

by a screw, m^2 , Figs. 1 and 14, whose head is fitted with a ratchet-wheel, I^4 . This ratchet-wheel is operated by a pawl, e^9 , which is pivoted to a lever, t^5 , that is constructed to oscillate freely upon the stem of the screw m^2 . One arm of this pawl-lever is within the range of vibration of the vibrating arm t^1 , so that at the rising vibration thereof the pawl e^9 is caused to vibrate, and the screw m^2 is thereby partly turned to move the pivot of the leg-lever Y^1 inward, while at the descending vibration of the arm t^1 the pawl-lever is permitted to carry the pawl backward over the ratchet-teeth by reason of the preponderating weight of the arm of the pawl-lever to which the pawl is pivoted, so that the pawl is put into position to turn the screw at the next rising vibration of the vibrating arm t^1 .

In order that the movement of the pivot of the leg-lever Y^1 may be stopped when the cone of yarn is properly formed at the head of the bobbin, at which time the vibration of the faller has attained its maximum extent, a guard, v , is secured to the side of the slide u' , so as to be carried by it over the arm x of the pawl-lever t^5 . This guard has two grades, x^1 and x^2 , (see Fig. 14,) the former being beyond the range of vibration of the arm x of the pawl-lever, so that while this grade is passing the pawl-lever it is permitted to oscillate, and the movement of the pivot by the vibration of the pawl and the turning of the pivot-screw m^2 proceeds.

The other grade, x^2 , of the guard is of sufficient extent to prevent the pawl-lever t^5 from vibrating; and when, by the movement of the slide u' , the pivot of the leg-lever Y^1 reaches the most inward position required, this grade x^2 of the guard is brought over the arm x of the pawl-lever, so as to stop the vibration of the pawl-lever, and, consequently, the further turning of the screw and the further movement of the pivot of the leg-lever Y^1 . When this stoppage takes place, the variation of the position which the faller occupies during its operation is under the control of the shifting-screw m^1 alone until the bobbins are filled with yarns. In order that the pivot of the leg-lever Y^1 may be set in the proper position for commencing winding upon an empty set of bobbins, the head of the pivot-screw m^2 is fitted with a crank-handle, p^4 , so that it can be turned by hand for that purpose, the pawl e^9 being then thrown out of gear with the ratchet-wheel I^4 .

When the yarn is wound nearest the head of a bobbin the distance between the top of the cone of yarn and the point of the spindle is greatest, and this distance progressively diminishes as the bobbin fills with yarn; hence, the amount of yarn extended from the top of the cone to the point of the bobbin must be progressively decreased at each operation of the spindle-carriage, and the faller must be permitted to rise (after winding) progressively later at each said operation. In order to produce this effect, the pivot of the arm t^3 is not

fixed to the carriage, but is connected with the slide u , and is moved with it, so that at every successive inward movement of the carriage the arm t^3 is brought in contact with the incline Z' at a later period, and consequently the faller is permitted to rise at a later period.

The operation of the winding mechanism is to turn the spindles with uniform speed during winding. As, however, the diameter of the cones of yarn upon the bobbins varies during winding, a uniform speed of the spindles sufficiently rapid to wind the yarn near the body of a bobbin would cause the straining or the breakage of the yarn while it was being wound near the base of the cone of yarn. To obviate such straining or breakage the machine is provided with a means of retarding the speed of the spindles during winding, according to the strain or tension of the yarns. To this end the carriage E is provided with a friction-brake, S^2 , Figs. 1 and 10, to bear against the drum S^1 , which drives the spindles, and to retard its motion during winding. The friction-brake is connected by a chain, n^2 , with an arm, y^1 , projecting from a rock-shaft, X^1 , from which shaft also project the arms y^2 y^2 that hold the counter-faller H' , across which the yarns pass. The end of the chain, after passing over a pulley, Q^6 , upon the arm y^1 of the rock-shaft, is made fast to an arm, y^3 , projecting from a rock-shaft, X^2 , arranged beneath the carriage, and the chain is long enough to permit the friction-brake S^2 to lie back (by its own weight) from the drum S^1 , while the chain-arm y^3 is horizontal, or thereabout.

In order to tauten the chain and thereby draw the friction-brake against the drum, the rock-shaft is fitted with a second arm, y^4 , which projects within the range of vibration of a stud, B^4 , projecting from the side of the leg-lever Y^1 . Hence, when that leg-lever Y^1 hangs down, as it does during the outward movement of the carriage while the spindles are being driven rapidly for twisting, the brake-chain n^2 is slacked, and the friction-brake lies clear from the drum S^1 ; but when the leg-lever Y^1 is raised, as before stated, for the purpose of depressing the faller H during the winding of the yarns, the stud B^4 , operating upon the arm y^4 of the rock-shaft X^2 , depresses the chain-arm y^3 , thereby tightening the chain n^2 and bringing the friction-brake S^2 into operation upon the drum S^1 and under the control of the counter-faller H' . Thereupon the pressure of the yarns extending from the roller-jaws to the bobbins across the counter-faller H' presses the friction-brake S^2 with greater or lesser force against the drum S^1 , according to the tension of said yarns, thereby retarding the revolution of the drum S^1 (and, consequently, of the spindles and bobbins driven by it) when the tension on the yarns increases, and relaxing it as the tension decreases.

In order that the pressure of the brake upon the drum may be relaxed with certainty as the tension upon the yarns decreases, springs

$z z$ are applied to arms $y^5 y^5$, Fig. 1, projecting from the rock-shaft X^1 of the counter-faller, opposite to the arms of the counter-faller, so that the counter-faller is under the action of two antagonistic forces—viz., that of the springs $z z$, tending to raise it, and that of the tension of the yarns, tending to depress it; hence the counter-faller vibrates during the winding of the yarns, and the brake S^2 is pressed more or less strongly against the drum S^1 , according as the tension of the yarns increases or decreases.

While the friction-brake S^2 tends to retard the revolution of the drum S^1 , the belt T , leading from the driving-shaft J^1 , tends to drive it at a uniform speed. In order that the drum and the driving-shaft J^1 may be permitted to turn as slowly as required under the circumstances, the turning gear-frame V is made in two parts, one of which, P , holds the arbors of the pinions $P^{14} P^{14}$, while the other, p^1 , holds the pin g^4 and projection g^5 , and has the form of a friction-band, being secured to the first part, p , only by frictional contact with the friction-blocks $p^2 p^2$, which are inserted between the two; hence the interior part, p , can turn within the exterior part, p^1 , whenever the shaft J^1 is retarded by the action of the friction-brake upon the drum S^1 .

In the winding mechanism which has been described, the tightness with which the yarn is wound depends upon the resistance which the friction-blocks or the band p^1 offer to the retardation of the shaft J^1 ; and in order that this may be varied as required, the exterior part, p^1 , of the frame is constructed as a friction-band, which can be tightened or slacked by screwing or unscrewing screws p^{17} , which connect the two ends of the band.

Instead of constructing the frame V in two parts, it may be made of one piece, provided the weight W be made heavy enough to insure the winding of the yarn with the required tension, and the stop m and projections $g^4 g^5$ be not used, so that the turning gear-frame may turn and wind up the weight. In this case the exterior of the turning gear-frame should have a helical groove formed upon it, or should have flanges applied to it, to keep the weight-cord from running off. Then the cord would extend radially from its point of fastening on the turning gear-frame to the first pulley, over which it passes during the stretching and hard twisting; but, during backing off and winding, the weight would be wound up by the revolution of the turning gear-frame. When, however, the driving-shaft J^1 was turned by the driving-belt, the turning gear-frame would be turned backward, and the weight would be lowered. In this case the weight would offer the resistance required to insure the winding of the yarns with the requisite tightness, and it would be varied to vary that tightness.

In the present example the differential gear is arranged in connection with the stationary frame of the machine; but it may be arranged

upon the spindle-carriage, and connected directly with the drum S^1 , through which the spindles are driven.

The counter-faller H' is held stationary near the points of the spindles during the outward movement of the carriage by means of a hook, s^2 , Fig. 1, and represented in dotted lines in Fig. 4, which is at that time engaged with a pin, s^3 , projecting from one of the arms y^2 of the counter-faller, and consequently the counter-faller then operates to guide the yarns to the points of the spindles. This hook s^2 is connected by a chain with an arm, y^6 , secured to the rock-shaft X of the faller H , so that when the faller is depressed for the purpose of guiding the yarns during winding, the hook s^2 is thereby disengaged from the pin s^3 , and the counter-faller is liberated and permitted to vibrate, as before described.

When the winding is completed it is expedient to secure the counter-faller in the position which it occupies near the points of the spindles during the outward movement of the carriage. To this end the rock-shaft X^1 of the counter-faller H' is fitted with an arm, y^7 , Figs. 1 and 4, which projects upward and backward from the said rock-shaft, while the counter-faller is free to vibrate, and which, during the last portion of the inward movement of the carriage, is thereby forced under the rail k^2 , Figs. 2 and 3, that carries the roller-jaws, and is thereby depressed, so as to depress the counter-faller and its arms $y^2 y^2$ until the hook s^2 re-engages with the pin s^3 . This downward movement of the counter-faller is permitted at the time because the disengagement of the hooked stop e^2 from the leg Y^2 at this time, and the consequent descent of the leg-lever Y^1 , as before described, releases the chain-arm Y^3 and slacks the chain n^2 , while the re-engagement of the hook s^2 with the arm of the counter-faller is permitted by the rise of the faller incident to the upward vibration of the vibrating lever t^1 at this time, as before set forth.

The mechanism for unwinding the rovings from the spools C , and for delivering the rovings, must operate intermittently, the movement of these mechanisms commencing when the carriage begins to move outward, and ceasing when a sufficient length of rovings has been delivered for one spinning operation. To this end the unwinding-drums B (upon which the spools C are laid during the operation of the machine, and by which they are turned) and the roller-jaws $D D^1$ are connected by the cog-wheels $f^2 f^3 f^4 f^5 f^6$ and the beveled wheels $f^7 f^8$ with a shaft, X^4 . This shaft is fitted with a clutch, T^2 , Fig. 2, which slides longitudinally upon it, and is connected with it by a feather and groove. The shaft is also fitted with a beveled wheel, f^9 , which turns freely upon it, and has its hub z^3 toothed, to engage with the teeth of the clutch T^2 , which is pressed toward that hub by a spring, x^3 .

The beveled wheel f^9 engages with a second beveled wheel, f^{10} , which is secured to a shaft, X^5 , and this shaft is caused to revolve by a

belt, U³, Fig. 3, and belt-pulleys Q³ Q⁹, the last of which, Q⁹, is secured to the second driving-shaft, J¹, of the machine.

The clutch T² is fitted with a clutch-lever, L³, one of whose arms projects upward from the rock-shaft I³, while its other arm, d⁴, Fig. 10, projects downward from that rock-shaft I³ within the range of revolution of a series of pins, g⁶ g⁷, which projects radially from the rim of a pin-wheel, P¹⁰. This pin-wheel is secured to the main shaft J⁴, and is turned by it, and its rim is perforated with many pin-holes, so that the pins may be set to project from the pin-wheel in any desired positions.

The arrangement of the clutch, clutch-lever, and pin-wheel is such that when the lower arm of the clutch-lever is not pressed by any pin the spring x³ can engage the clutch T² with the hub of the wheel f⁹, while if the clutch be engaged the pressure of a pin, g⁶, (of the pin-wheel P¹⁰) upon the clutch-lever L³ causes the disengagement of the clutch, and holds it out of engagement so long as the pin presses against the lower curved arm, d⁴, of that clutch-lever. When the clutch is engaged the roller-jaws and the unwinding-drums are connected with the second driving-shaft, J¹, and are put in motion by it; and when the clutch is disengaged the roller-jaws and unwinding-drums are disconnected from the said driving-shaft, and consequently cease to deliver rovings.

In adjusting the machine for use a pin, g⁶, is placed in the pin-wheel P¹⁰, in the proper position to bear against the clutch-lever L³, and thereby disengage the clutch when the carriage (which receives motion through the same main shaft) has reached that point in its outward movement at which the delivery of rovings is to be stopped; and a sufficient number of additional pins, g⁷, is inserted in the wheel to bear in succession against the clutch-lever, and hold the clutch disengaged until the driving-shaft J¹ is stopped by the shifting of its driving-belt by the movement of the belt-shipper U. As the turning of the pin-wheel P¹⁰ with the main shaft J⁴ continues after the second driving-shaft, J¹, is stopped, the last pin g⁷, which bears against the clutch-lever L³, is moved past the clutch-lever in the interval between the stopping and restarting of the second driving-shaft, J¹, which drives the spindles, and consequently the clutch is engaged, and the delivery of rovings commences when the second driving-shaft is started into motion for each operation of the carriage.

In practice it has been found expedient to proportion the parts of the machine as follows: The pinion N has twenty teeth. The main wheel P has one hundred teeth. The pinion N¹ has fourteen teeth. The sister-wheel P⁹ has ninety-eight teeth. The pinion N³ has fourteen teeth. The segment P¹ has seventy-two teeth. The segment P³ has forty-one teeth. The pinion N³ has twenty-four teeth. The ratchet-wheel I has eight teeth.

The teeth of the wheel P⁴, P⁵, and pinion P⁶ are

so proportioned that the shaft J⁵ makes one-quarter of the number of revolutions of the shaft J³ of the pinion N¹. The main shaft J⁴ makes one complete revolution for each complete operation of the spindle-carriage. The sister-wheel P⁹ also makes one complete revolution for each operation of said carriage. The angular distances or spaces between the centers of the pin-holes of the sister-wheel correspond with the angular distances of the ratchet-teeth of the ratchet-wheel I, each space of the former corresponding with one tooth of the latter.

The sprocket-wheel is of sufficient diameter to effect a complete round movement of the chain by five revolutions of that wheel.

Having thus described a self-acting jack embodying all my improvements, what I claim as my invention, and desire to secure by Letters Patent, is—

1. The combination of the carriage for the spindles with the endless chain, the segment-wheel, and the pinion, for transmitting a uniform motion to the carriage during the delivery of rovings and during the winding of the yarns, and for automatically ceasing to operate the carriage when it is to be operated by other mechanism, the whole constructed to operate substantially as hereinbefore set forth.

2. Also, the combination of the spindle-carriage with the endless chain, the cam-plate, and the crank-pin revolving eccentrically to the cam-plate, for transmitting a progressively-decreasing speed of motion to the carriage during the stretching of the rovings, the whole constructed to operate substantially as before set forth.

3. Also, the combination of the spindle-carriage with the endless chain and the pawl for stopping the movement of the carriage when the stretching of the rovings is completed, the whole constructed to operate substantially as before set forth.

4. Also, the combination of the spindle-carriage with the endless chain, sister-wheel, pinion, cam, and pawl, for moving the carriage inward during the hard twisting of the yarns, the whole constructed to operate substantially as before set forth.

5. Also, the combination of the spindle-carriage with the endless chain, main wheel, sister-wheel, and pins, for the purpose of placing the carriage under the control of the train of mechanism for operating it during the winding of the yarns, the whole constructed to operate substantially as before set forth.

6. Also, the combination of the spindle-carriage, the endless chain, and the pawl with the mechanism for varying the position of the pawl at the time it stops the movement of the carriage, the whole constructed to operate substantially as before set forth.

7. Also, the combination of the driving-shaft of the spindles with the belt-shipper, spring-catch, and main shaft, in such manner that the forward motion of the spindles is stopped when the hard twisting is completed, the whole

constructed to operate substantially as before set forth.

8. Also, the combination of the driving-shaft of the spindles with the driving-shaft of the spindle-carriage through the intervention of the ratchet-wheel, pawl, and arm, in such manner that the spindles are caused to turn backward, for the purpose of backing off the yarns, the whole constructed to operate substantially as before set forth.

9. Also, the combination of the driving-shaft of the spindles with the sprocket-wheel shaft, ratchet-wheel, and pawl, for the purpose of driving the spindles during the winding of the yarns, the whole constructed to operate substantially as before set forth.

10. Also, the combination of the drum which imparts motion to the spindles with the turning gear-frame, the whole constructed to operate substantially as before set forth.

11. Also, the combination of the driving-shaft of the spindles with the turning gear-frame and the weight which is connected therewith, the whole constructed to operate substantially as before set forth.

12. Also, the combination of the faller with the vibrating arm, the leg, and the track, for the purpose of operating the faller during the winding of the yarn, the whole constructed to operate substantially as before set forth.

13. Also, the combination of the faller, the vibrating arm, the leg, and the track with the stop for holding the leg erect, and with the incline for releasing the stop from the leg when the winding of the yarns is completed, the whole constructed to operate substantially as before set forth.

14. Also, the combination of the faller, the vibrating arm, the leg, and the track with the shifting-screw, for varying the length of the connection with the faller, so that the place of operation of the faller is varied progressively from the heads of the spindles toward their points, the whole constructed to operate substantially as before set forth.

15. Also, the combination of the faller, the vibrating arm, the leg, and the leg-lever with the pivot-screw for shifting the pivot of the leg-lever, so as to increase the vibration of the faller, the whole constructed to operate substantially as before set forth.

16. Also, the combination of the faller, the vibrating arm, the leg-lever, and the pivot screw with the guard for stopping the movement of the pivot-screw when the vibration of the faller has attained the required extent, the whole constructed to operate substantially as before set forth.

17. Also, the combination of the faller, the vibrating arm, the leg, and the stop for holding the leg erect with the arm for disengaging the stop and the screw for moving said arm, so as to vary the period of disengagement, the whole constructed to operate substantially as before set forth.

18. Also, the combination of the counter-faller, the drum for driving the spindles, and the friction-brake for modifying the speed of that drum, the whole constructed and operating substantially as before set forth.

19. Also, the combination of the counter-faller, the friction-brake, and the arm for tightening and slacking the connection between the counter-faller and the friction-brake, so as to put the friction-brake into operation and out of operation, as required, the whole constructed to operate substantially as before set forth.

20. Also, the combination of the drum that imparts motion to the spindles, the driving-shaft for driving them, and the turning gear-frame with the means of varying the resistance to the movement of the turning gear-frame, the whole constructed to operate substantially as before set forth.

21. Also, the combination of the counter-faller, the faller, the hook for holding the counter-faller, and the connection between the counter-faller and the faller, the whole constructed to operate substantially as before set forth.

22. Also, the combination of the unwinding-drums, the driving-shaft of the spindles, the main shaft, and the clutch, by means substantially as described, so that the unwinding of rovings stops when the carriage has reached the place at which the delivery of rovings is to be stopped, the whole constructed to operate substantially as before set forth.

23. Also, the combination of the roller-jaws, the driving-shaft of the spindles, the main shaft, and the clutch, by means substantially as described, so that the delivery of rovings is stopped when the length required for one operation of the spindles has been delivered, the whole constructed to operate substantially as before set forth.

In testimony whereof I have hereto set my hand this 4th day of March, A. D. 1869.

EDWARD E. KILBOURN.

Witnesses:

GEO. W. DAVIES,
NICH. S. WINCKLER.