



- (51) **International Patent Classification:**  
*E04F 15/02 (2006.01)*
- (21) **International Application Number:**  
PCT/SE2014/050360
- (22) **International Filing Date:**  
25 March 2014 (25.03.2014)
- (25) **Filing Language:** English
- (26) **Publication Language:** English
- (30) **Priority Data:**  
1350377-6 25 March 2013 (25.03.2013) SE
- (71) **Applicant: VÄLINGE INNOVATION AB [SE/SE];**  
Prastavagen 5 13, S-263 65 Viken (SE).
- (72) **Inventor: BOO, Christian;** Tvargatan 8, S-268 77 Kageröd (SE).
- (74) **Agent: WESTEMAN, Maria;** Valinge Innovation AB, Prastavagen 5 13, S-263 65 Viken (SE).
- (81) **Designated States (unless otherwise indicated, for every kind of national protection available):** AE, AG, AL, AM, AO, AT, AU, AZ, BA, BB, BG, BH, BN, BR, BW, BY, BZ, CA, CH, CL, CN, CO, CR, CU, CZ, DE, DK, DM,

DO, DZ, EC, EE, EG, ES, FI, GB, GD, GE, GH, GM, GT, HN, HR, HU, ID, IL, IN, IR, IS, JP, KE, KG, KN, KP, KR, KZ, LA, LC, LK, LR, LS, LT, LU, LY, MA, MD, ME, MG, MK, MN, MW, MX, MY, MZ, NA, NG, NI, NO, NZ, OM, PA, PE, PG, PH, PL, PT, QA, RO, RS, RU, RW, SA, SC, SD, SE, SG, SK, SL, SM, ST, SV, SY, TH, TJ, TM, TN, TR, TT, TZ, UA, UG, US, UZ, VC, VN, ZA, ZM, ZW.

- (84) **Designated States (unless otherwise indicated, for every kind of regional protection available):** ARIPO (BW, GH, GM, KE, LR, LS, MW, MZ, NA, RW, SD, SL, SZ, TZ, UG, ZM, ZW), Eurasian (AM, AZ, BY, KG, KZ, RU, TJ, TM), European (AL, AT, BE, BG, CH, CY, CZ, DE, DK, EE, ES, FI, FR, GB, GR, HR, HU, IE, IS, IT, LT, LU, LV, MC, MK, MT, NL, NO, PL, PT, RO, RS, SE, SI, SK, SM, TR), OAPI (BF, BJ, CF, CG, CI, CM, GA, GN, GQ, GW, KM, ML, MR, NE, SN, TD, TG).

**Declarations under Rule 4.17:**

- as to applicant's entitlement to apply for and be granted a patent (Rule 4.17(H))

**Published:**

- with international search report (Art. 21(3))

(54) **Title:** FLOORBOARDS PROVIDED WITH A MECHANICAL LOCKING SYSTEM AND A METHOD TO PRODUCE SUCH A LOCKING SYSTEM

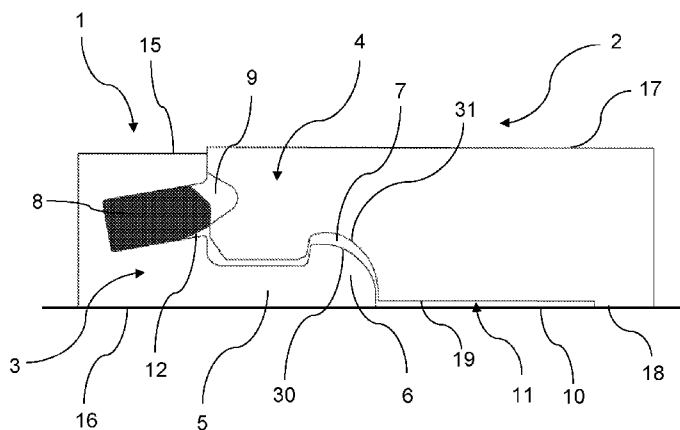

Fig. 2

(57) **Abstract:** The present disclosure relates to floorboards provided with a mechanical locking system comprising a locking strip (5) protruding from a first edge (3) of a first floorboard. The locking strip (5) is provided with a locking element (6) configured to cooperate with a locking element (6) configured to cooperate with a locking groove (7) at a lower side (18) of a second edge (4) of a second floorboard (2) for locking the first edge (3) and the second edge (4) in a horizontal direction. The first edge (3) and the second edge (4) are configured to be assembled by a vertical downward motion of the second edge (4) towards the first edge (3). The second edge (4) is provided with a calibrating groove (11) adjacent the locking groove (7). The disclosure also relates to a method for producing a mechanical locking system.

Floorboards provided with a mechanical locking system and a method to produce such a locking system

### **Technical Field**

The present disclosure relates to floorboards provided with a mechanical locking system, and a method for producing a mechanical locking system at  
5 edges of floorboards.

### **Technical background**

Due to tolerances allowed during manufacturing, the thickness of different floorboards may slightly differ. As a consequence, different portions of  
10 a mechanical locking system may be arranged at different heights of the floorboards. For example, the distance from the sub floor on which the floorboards are arranged to a tongue arranged on a first floorboard may be different from the distance from the sub floor to a tongue groove of a second floorboard, into which the tongue is to be inserted for locking in a vertical  
15 direction, which is shown in Fig. 1. This may result in difficulties when joining the floorboards, since the floorboards may not enter into a locking position. However, such differences in thickness of the floorboards usually does not results in problems when locking the floorboards together when the floorboards are arranged on a foam provided on the sub-floor. Such a foam is usually  
20 compressible. The compressible foam allows a thicker floorboard to be pressed towards the sub-floor such that the tongue groove on the thicker floorboard is positioned at the same height as the tongue of an adjacent floorboard.

Such an underlying foam is conventionally used when installing laminate flooring, engineered wood floorings, etc. When installing floors made of plastics,  
25 such as vinyl floorings, for example LVT (Luxury Vinyl Tiles), such a foam is not conventionally used.

As a result, the differences in thickness between different floorboards may result in difficulties when locking the floorboards together, especially when joining the floorboards by a so called fold down technique. The fold down  
30 technique involves assembling the floorboards by a vertical downward movement of one edge of one of the floorboards. As described above, floorboards having different thickness may result in the tongue groove of one floorboard being positioned at a different height than the tongue of the adjacent floorboard, resulting in difficulties when joining the floorboards, because the  
35 floorboards may not enter into a locking position.

### Summary

It is an object of at least certain embodiments of the present invention to provide an improvement over the above described techniques and known art.

5 A further object of at least certain embodiments of the present invention is to facilitate locking of floorboards by means of a mechanical locking system.

Another object of at least certain embodiment of the present invention is to facilitate locking of floorboards by means of a mechanical locking system when the floorboards have different thicknesses.

10 A further object of at least certain embodiment of the present invention is to facilitate locking of floorboards by means of a mechanical locking system when no underlying foam is used.

At least some of these and other objects and advantages that will be apparent from the present disclosure have been achieved by floorboards  
15 provided with a mechanical locking system comprising a locking strip protruding from a first edge of a first floorboard, wherein the locking strip is provided with a locking element configured to cooperate with a locking groove at a lower side of a second edge of a second floorboard for locking the first and second edge in the horizontal direction. The first and the second edges are  
20 configured to be assembled by a vertical downward motion of the second edge towards the first edge. The second edge is provided with a calibrating groove adjacent the locking groove.

An advantage of embodiments of the present invention is that the calibrating groove compensates for floorboards having different thicknesses,  
25 especially a difference in thickness at the edges of the floorboards. The calibrating groove allows the second edge to be pushed towards a sub-floor on which the floorboards are arranged. Thereby, the second edge may be displaced such that an upper side of the second floorboard is aligned with an upper side of the first floorboard at the first and second edges, respectively, even if the  
30 thickness of the second floorboard exceeds the thickness of the first floorboard.

Another advantage of embodiments of the present invention is that locking of the floorboards may be facilitated. Conventionally, due to different floorboards having different thicknesses, locking of portions of the mechanical locking system such as a tongue and a tongue groove, may be hindered. The  
35 tongue may have difficulties in entering into engagement with the tongue groove for locking as discussed above. By providing the calibrating groove of the

present disclosure, the second edge may be bent downwards until a locking position in which the tongue enters into the tongue groove is reached.

At least the second edge may be flexible.

5 At least the second floorboard may be flexible. The flexibility or resiliency of the second edge, or of the floorboard, allows the second edge to be bent downwards towards the sub-floor.

At least the second floorboard may comprise a plastic material, preferably a thermoplastic material, or an elastomer.

10 A core of the second floorboard may comprise a plastic material, preferably a thermoplastic material, or an elastomer.

The calibrating groove may be open towards the locking groove.

The depth of the calibrating groove may substantially equal or exceed a mean variation in thickness between the floorboards.

15 The depth of the calibrating groove may substantially equal a difference in thickness between the first and the second floorboard at the first and the second edge.

The calibrating groove may be arranged at the lower side of the second floorboard.

20 The locking element may comprise a curved outer upper part. The locking groove may have a shape complimentary to the shape of the locking element.

The first or the second edge may be provided with a tongue configured to cooperate with a tongue groove at the other of the first or the second edge for locking the first and the second edge in the vertical direction.

25 The tongue may be formed of the same material as the first or the second edge.

The tongue may be provided at the second edge and extend vertically downward from an upper side of the second floorboard.

The width of the tongue may increase with a distance from the upper side of the second floorboard.

30 The tongue may be a displaceable tongue arranged in a displacement groove. The displaceable tongue may be configured to enter into engagement with the tongue groove when the floorboards are in a locking position.

35 According to a second aspect of the invention, the present invention is realised by a method for producing a mechanical locking system at edges of a first and second floorboard. The method comprises the step of:

providing a first and a second floorboard, wherein the first floorboard has

a first thickness and the second floorboard has a second thickness different from the first thickness,

forming a locking groove at a lower side of a second edge of the first and second floorboard, and

- 5 forming a calibrating groove at the lower side of the second edge of at least one of the first and second floorboard with a tool, wherein the tool is positioned at a fixed position relative an upper side of the first and second floorboard.

10 The method according to the second aspect of the present invention may incorporate the advantages of the floorboards, which have previously been discussed such that the previous discussion is applicable also to the method for producing a mechanical locking system.

The method may further comprise positioning a bottom surface of the calibrating groove at a fixed distance from the upper side of the first and second floorboard.

15 The bottom surface of the calibrating groove may positioned such that a depth of the calibrating groove substantially equals or exceeds a mean variation in thickness between the floorboards.

The bottom surface of the calibrating groove may be positioned such that a depth of the calibrating groove substantially equals a difference in thickness between the first and the second floorboard.

The locking groove and the calibrating groove may be formed adjacent each other.

25 The calibrating groove may be open towards the locking groove. The calibrating groove may be arranged at the lower side of the second floorboard.

The method may further comprise forming a locking strip provided with a locking element at a first edge of the first and second floorboards, wherein the locking element is configured to cooperate with the locking groove. The locking element may be configured to cooperate with the locking groove for locking in a horizontal direction.

30 The method may further comprise forming a tongue groove at the first edge or the second edge of the first floorboard and the second floorboard, and providing a tongue at the other of the first edge and the second edge of the first floorboard and the second floorboard, wherein tongue is configured to cooperate with the tongue groove. The tongue may be configured to cooperate with the tongue groove for locking in a vertical direction.

The step of providing a tongue may comprise forming a displacement groove at the other of the first edge and the second edge of the first floorboard and the second floorboard, and inserting the tongue in the displacement groove, the tongue being displaceable in the displacement groove.

5

### **Brief description of the drawings**

The present invention will by way of example be described in more detail with reference to the attached drawings, which show embodiments of the present invention.

10

Fig. 1 shows floorboards arranged on sub-floor according to known art.

Fig. 2 shows floorboards according to an embodiment of the present invention.

Fig. 3 shows the floorboards of Fig. 2 in a locked position.

15

Fig. 4 shows floorboards according to another embodiment of the present invention.

Fig. 5 shows the floorboards of Fig. 4 in a locked position.

Fig. 6a shows a cross-section of a first floorboard.

Fig. 6b shows a cross-section of a second floorboard.

20

### **Detailed description**

Figs. 2, 3, 4 and 5 show a mechanical locking system of a set of floorboards comprising at least a first floorboard 1 and a second floorboard 2. Figs. 6a and 6b show the first floorboard 1 and the second floorboard 2, respectively. The first and second floorboards 1, 2 are arranged on a sub-floor 10. The first floorboard 1 has an upper side 15 facing away from the sub-floor 10 and a lower side 16 facing toward the sub-floor 10. The second floorboard 2 has an upper side 17 facing away from the sub-floor 10 and a lower side 18 facing toward the sub-floor 10.

25

The first and second floorboards 1, 2 are provided with the mechanical locking system. The mechanical locking system comprises a locking strip 5. The locking strip 5 protrudes from a first edge 3 of the first floorboard 1. The locking strip 5 is provided with a locking element 6. The locking element 6 is configured to cooperate with a locking groove 7 arranged at the lower side 18 of a second edge 4 of the second floorboard 2 for locking the first and second edges 3, 4 in a horizontal direction.

35

The locking element 6 has an outer upper portion 30. The locking groove 7 has an outer lower portion 31. In the embodiment shown in Figs. 2 and 3, the locking element 6 has a curved or rounded outer upper portion 30. The curved upper portion 30 may be shaped as a part of a circle or ellipse. The locking groove 7 may have a shape complimentary to the shape of the locking element 6. That is, the outer lower portion 31 of the locking groove 7 may be curved or rounded. In the embodiment shown in Figs. 4 and 5, the locking element 6 has an inclined outer upper portion 32. The locking groove 7 may have a shape complimentary to the shape of the locking element 6. That is, the outer lower portion 33 of the locking groove 7 may be inclined. Further, a lower part of the locking element 6 facing the sub-floor 10 may be inclined relative to the sub-floor 10 as shown in Figs. 4 and 5.

The first and second edges 3, 4 are configured to be assembled and locked together by a vertical downward motion of the second edge 4 towards the first edge 3.

The mechanical locking system may further comprise a tongue 8 and a tongue groove 9. The tongue 8 may be arranged at the first edge 3 or the second edge 4. The tongue groove 9 may be arranged at the other of the first edge 3 and the second edge 4. The tongue 8 is configured to cooperate with the tongue groove 9 for locking the first edge 3 and the second edge 4 in a vertical direction. The tongue 8 may protrude from the first edge 3 at an angle relative to the upper side 15 of the first floorboard 1 as shown in Figs. 2 and 3. Alternatively, the tongue 8 may protrude from the first edge 3 in a horizontal direction with an angle.

As shown in Figs. 2 and 3, the tongue 8 may be a displaceable tongue arranged in a displacement groove 12 at the first edge 3 or the second edge 4. The displaceable tongue 8 may be formed as a separate part. That is, the displaceable tongue 8 may be formed of a different material than the material of the first and second floorboards 1, 2. Such a displaceable tongue 8 is for example described in WO2007/015669. In the embodiment shown in Figs. 2 and 3, the tongue 8 is a displaceable tongue arranged in a displacement groove 12 at the first edge 3. The tongue groove 9 is arranged at the second edge 4. The displaceable tongue 8 is displaceable within the displacement groove 12. The displaceable tongue 8 is configured to cooperate with the tongue groove 9 for locking the first edge 3 and the second edge 4 in a vertical direction.

In the embodiment shown in Figs. 4 and 5, the tongue 13 may be formed of the same material as the first edge 3 or the second edge 4. The tongue 13 may be an integrated part of the first edge 3 or the second edge 4. In Figs. 4 and 5, the tongue 13 is formed of the same material as the second edge 4. The tongue  
5 groove 14 is formed at the first edge 3. The tongue 13 is preferably configured to cooperate with the tongue groove 14 for locking the first edge 3 and the second edge 4 in a vertical direction. In the embodiment shown in Figs. 4 and 5, the tongue 13 extends vertically downward from the upper side 17 and protrudes horizontally. The width of the tongue 13 increases with the distance from the  
10 upper surface 17 of the second panel 2. The tongue 13 may have a dovetailed shape as seen in cross-section.

The first and second edges 3, 4 may be short edges of the first and second floorboards 1, 2, respectively. The long edges of the first and second floorboards 1, 2 may also be provided with a mechanical locking system. For example, the  
15 long edges may be provided with a mechanical locking system configured for locking floorboards together by angling. Alternatively, the long edges may be provided with a mechanical locking system of the type described above. It is also contemplated that the floorboards may be square shaped, rectangular shaped or any other polygonal shape.

In embodiments, at least the second edge 4 is flexible, elastic or resilient, such that the second edge 4 may be pushed in a vertical direction. The second edge 4 is preferably pushed downwards in the vertical direction towards the sub-floor 10. In one embodiment, the first and second floorboards 1, 2 are flexible, elastic, or resilient. The first and second floorboards 1, 2 may in this  
20 embodiment comprise a plastic material, preferably a thermoplastic material such as polyvinyl chloride (PVC), polyurethane (PU and/or PUR), polypropylene (PP), or polyethylene (PE), or a combination thereof. The thermoplastic material may be polystyrene (PS), polyethylene terephthalate (PET), polyacrylate, polyvinyl butyral, or a combination thereof. The first and second floorboards 1, 2  
25 may also comprise an elastomer. The first and second floorboards 1, 2 may comprise a WPC (Wood Plastic Composite). The resiliency of the second edge 4 may also be obtained by removing material from the second edge 4.

In embodiments, the first and second floorboards 1, 2 may comprise one or more layers. The first and second floorboards 1, 2 may comprise a core. The  
35 mechanical locking system may be formed in the core. The first and second floorboards 1, 2 may further comprise a surface layer, preferably a decorative

surface layer or a print layer arranged on an upper side of the core. The surface layer may further comprise a wear resistant layer arranged on the decorative surface layer or the print layer. The first and second floorboards 1, 2 may further comprise a backing layer arranged on a lower side of the core. The core may  
5 provide the second edge 4 flexible or resilient properties. The core may comprise a plastic material, preferably a thermoplastic material such as polyvinyl chloride (PVC), polyurethane (PU), polypropylene (PP), or polyethylene (PE), or a combination thereof. The thermoplastic material may be polystyrene (PS), polyethylene terephthalate (PET), polyacrylate, polyvinyl  
10 butyral, or a combination thereof. The core may also comprise a WPC (Wood Plastic Composite). The core may also comprise an elastomer. It is also contemplated that the core may comprise more than one layer. For example, the core may comprise a first layer of a wood fibre based panel such as MDF or HDF and a second layer of a resilient material such as plastic, preferably comprising a  
15 thermoplastic material or an elastomer.

The first and second floorboards 1, 2 may be resilient floorboards such as Luxury Vinyl Tiles or Planks, vinyl free floorings, etc. The first and second floorboards 1, 2 may comprise a core, a surface layer arranged on an upper side of the core, and optionally a backing layer arranged on a lower side of the core.  
20 The core may comprise a thermoplastic material such as polyvinyl chloride (PVC), polyurethane (PU), polypropylene (PP), or polyethylene (PE). The core may comprise an elastomer. The surface layer may comprise one or more layers, such as a print layer, a wear resistant layer and a protective coating. The print layer and/or the wear resistant layer may comprise a thermoplastic material  
25 such as a thermoplastic foil. The thermoplastic material of the print layer and the wear resistant layer may be polyvinyl chloride (PVC), polyester, polypropylene (PP), polyethylene (PE), polystyrene (PS), polyurethane (PUR), polyethylene terephthalate (PET), polyacrylate, polyvinyl butyral, or a combination thereof. The protective coating may be a radiation curable coating such as UV curable  
30 coating.

As shown in Figs. 2 and 3, and in Figs. 4 and 5, the second edge 4 is provided with a calibrating groove 11. The calibrating groove 11 is arranged adjacent the locking groove 7. The calibrating groove 11 is arranged at a lower side 18 of the second floorboard 2. The calibrating groove 11 extends to the  
35 locking groove 7. The calibrating groove 11 is open towards the locking groove 7. The calibrating groove 11 extends from the lower side 18 of the floorboard 2

in a vertical direction. The calibrating groove 11 has a bottom surface 19, which may extend in a horizontal direction, or may be inclined.

In an embodiment in which the second floorboard 2 at the second edge 4 comprises a core, the calibrating groove 11 may be formed in the core. In an  
5 embodiment in which the second floorboard 2 at the second edge 4 comprises a core and a backing layer at the lower side of the core, the calibrating groove 11 may be formed in the backing layer, or in the backing layer and the core.

The calibrating groove 11 is configured to adjust to differences in thickness between the first and second floorboards 1, 2, and especially  
10 configured to adjust to a difference in thickness at the first and second edges 3, 4 of the first and second floorboards 1, 2, respectively. As seen in Figs. 2 and 4, the thickness of the second floorboard 2 at the second edge 4 exceeds the thickness of the first floorboard 1 at the first edge 3. As a consequence, the tongue groove 9 is arranged above the tongue 8 such that the tongue 8 is hindered from  
15 entering into cooperation with the tongue groove 9, as shown in Fig. 2. In the embodiment shown in Fig. 4, the tongue 13 is only partly inserted into the tongue groove 14. The locking surfaces of the tongue 13 and tongue groove 14 are only partly in engagement.

When arranged on the sub-floor 10, the presence of the calibrating groove  
20 11 at the second edge 4 results in a distance being formed between the sub-floor 10 and the floorboard 2 at the second edge 4. The calibrating groove 11 allows that the second edge 4 to be pushed towards the sub-floor 10 to a position wherein the tongue 8, 13 can enter into engagement with the tongue groove 9, 14, which is shown in Figs. 3 and 5. When the tongue 8, 13 engages with the  
25 tongue groove 9, 14, the first edge 3 and the second edge 4 are locked in the vertical direction. As seen in Figs. 3 and 5, at least a portion of a bottom surface 19 of the calibrating groove 11 is abutting the sub-floor 10. The engagement of the tongue 8, 13 in the tongue groove 9, 14 locks the first edge 3 and the second edge 4 in a position wherein the second edge 4 is bent towards the sub-floor 10.  
30 Preferably, the upper side 17 of the second floorboard 2 at the second edge 4 is aligned with the upper side 15 of the first floorboard 1 at the first edge 3 when the tongue 8, 13 has entered into engagement with the tongue groove 9, 14.

Preferably, the flexible or resilient properties of the second floorboard 2, or of the core of the second floorboard 2, help achieve the desired bending at the  
35 second edge 4. The width of the calibrating groove 11 in a horizontal direction parallel to the upper surface 17 and perpendicular to a joint plane 34 may be

adjusted to material properties of the second floorboard 2. If the second floorboard 2 is more rigid, the width of the calibrating groove 11 should be increased in order to obtain the desired bending at the second edge 4. If the second floorboard 2 is more flexible and/or resilient, the width of the calibrating groove 11 can be reduced compared to the more rigid floorboard. By adjusting the width of the calibrating groove 11, the desired flexibility and resiliency of the second floorboard 2 for allowing bending of the second edge 4 towards the sub-floor 10 can be achieved.

The calibrating groove 11 preferably extends along the extension of the second edge 4 in a horizontal direction parallel to the upper surface 17 and horizontally along the joint plane 34. The calibrating groove 11 is preferably continuous. In an alternative embodiment, the calibrating groove 11 may be non-continuous in the horizontal direction parallel to the upper surface 17 and horizontally along the joint plane 34.

Preferably, the depth of the calibrating groove 11 substantially equals the difference in thickness between the first floorboard 1 and the second floorboard 2. Preferably, the depth of the calibrating groove 11 is less than 0.5 mm, preferably less than 0.3 mm, more preferably less than 0.2 mm.

The calibrating groove 11 can be formed when forming the mechanical locking system. The depth of the calibrating groove 11 can be chosen as a mean difference in thickness between several floorboards, or as a depth exceeding the mean difference in thickness between several floorboards. Floorboards having a thickness exceeding a desired thickness may be provided with a calibrating groove 11. Floorboards having a thickness less than the desired thickness may not be provided with any calibrating groove 11.

Fig. 6a shows the first floorboard 1 in cross-section. The first floorboard 1 comprises the first edge 3 and a second edge 24. Fig. 6b shows the second floorboard 2 in cross-section. The second floorboard 2 comprises the second edge 4 and a first edge 23. The first and second floorboards 1, 2 in Figs. 6a-6b correspond to the first and second floorboards 1, 2 in Figs. 2-5 described above. Figs. 2-5 show joining of the first and second floorboards 1, 2 while Figs. 6a-6b show the floorboards separately. The description of the first and second floorboards 1, 2 with reference to Figs. 2-5 above is applicable also for the first and second floorboards 1, 2 described below with reference to Figs. 6a-6b, and vice versa.

A method of forming a mechanical locking system at edges of the first and second floorboards 1, 2 will now be described with reference to Figs. 6a-6b. A locking groove 27 is formed at a lower side 16 of the second edge 24 of the first floorboard 1 having a first thickness. A locking groove 7 is also formed at a lower side 18 of the second edge 4 of the second floorboard 2 having a second thickness. The thickness of the first floorboard 1 may differ from the thickness of the second floorboard 2.

If the thickness of any one of the first and second floorboards 1, 2, preferably measured at the second edge 4, 24 where the locking groove 7, 27 is formed, exceeds a predetermined thickness, a calibrating groove 11 is formed in that floorboard. If the thickness is equal to or less than a predetermined thickness, no calibrating groove is formed. In Figs. 6a-6b, a calibrating groove 11 has been formed in both the first and second floorboards 1,2.

The calibrating groove 11 is formed by a tool 40. The tool 40 is positioned at a fixed distance from an upper side 15, 17 of the first floorboard 1 and the second floorboard 2. The fixed distance is the same between the upper side 15 of the first floorboard 1 and the tool 40 and between the upper side 17 of the second floorboard 2 and the tool 40. The fixed distance corresponds to a predetermined desired value of the thickness. The predetermined desired value may correspond to a mean thickness of at least the first and second floorboards.

By the tool 40 being arranged at a fixed position, any floorboard having a thickness exceeding said distance will be provided with a calibrating groove 11. The tool 40 may be a knife, a heating device adapted to melt a portion of the floorboard, a scraping tool, a carving tool, etc.

The first floorboard 1 and the second floorboard 2 are preferably conveyed by the same conveyor element when the floorboards 1, 2 pass the tool 40. The distance between the conveyor element and the tool 40 is fixed. Preferably, the upper side 15, 17 of the first floorboard 1 and the second floorboard 2, respectively, abut the conveyor element.

The calibrating groove 11 is formed at the lower side 16, 18 of the second edge 4, 24 of the first and second floorboards 1, 2. The calibrating groove 11 may be formed by cutting, scraping, or melting a portion of the floorboard. The calibrating groove 11 is formed such that the calibrating groove 11 is open towards the locking groove 7, 27. The calibrating groove 11 is arranged adjacent the locking groove 7, 27. Preferably, the first and second floorboards 1, 2 are conveyed in a horizontal direction between a first position wherein the locking

groove 7, 27 is formed and a second position wherein the calibrating groove 11 is formed.

The calibrating groove 11 has a bottom surface 19. The calibrating groove 11 is formed such that the bottom surface 19 of the calibrating groove 11 of a first floorboard 1 and the bottom surface 19 of the calibrating groove 11 of a second floorboard 2 are positioned at substantially the same distance from the upper side 15, 17 of the first and second floorboards 1, 2, respectively. A distance between the upper side 15, 17 of a respective floorboard and the bottom surface 19 of each calibrating groove 11 is essentially the same for the first and second floorboards 1, 2. Even if the first and second floorboards 1, 2 have a different thickness, the bottom surface 19 of each calibrating groove 11 is positioned at a substantially equal distance from the upper side 15, 17 of the respective first and second floorboards 1, 2. Consequently, the depth of the calibrating groove 11 may differ from one floorboard to another depending on the original thickness of the floorboard at the second edge 4, 24.

The method may further comprise forming a locking strip 5 provided with a locking element 6 at the first edge 3 of the first floorboard 1 and forming a locking strip 25 provided with a locking element 26 at the first edge 23 of the second floorboard 2. The locking element 6, 26 is configured to cooperate with the locking groove 7, 27 for locking in a horizontal direction.

The method may further comprise forming a tongue groove 9 at the second edge 4 of the second floorboard 2 and forming a tongue groove 29 at the second edge 24 of the first floorboard 1. A displacement groove 12 may be formed at the first edge 3 of the first floorboard 1 and a displacement groove 22 is formed at the first edge 23 of the second floorboard 2. The method may further comprise inserting a displaceable tongue 8 into each displacement groove 12 and 22 as shown in Figs. 6a-6b. The displaceable tongue 8 is displaceable within the displacement groove 12, 22. The displaceable tongue 8 is adapted to lock the floorboards in the vertical direction. Alternatively, vertical locking may be obtained by the tongue 13 and the tongue groove 14 shown in Figs. 4 and 5.

It is to be understood that the locking strip 25, the locking element 26 and the displacement groove 22 of the first edge 23 of the second floorboard 2 essentially correspond to the locking strip 5, the locking element 6 and the displacement groove 12 of the first edge 3 of the first floorboard 1, and that the description above with reference to Figs. 2-5 also is applicable to Figs. 6a-6b.

It is to be understood that locking groove 27 and the tongue groove 29 of the second edge 24 of the first floorboard 1 essentially correspond to the locking groove 7 and the tongue groove 9 of the second edge 4 of the second floorboard 2, and that the description above with reference to Figs. 2-5 also is applicable to  
5 Figs. 6a-6b.

The first and second edges 3, 4, 23, 24 may be short edges of the first and second floorboards 1, 2. The long edges of the first and second floorboards 1, 2 may be provided with a mechanical locking system. For example, the long edges may be provided with a mechanical locking system configured for locking  
10 floorboards together by angling. Alternatively, the long edges may be provided with a mechanical locking system of the type described above. It is also contemplated that the floorboards may be square shaped, rectangular shaped or any other shape.

By upper side 15, 17 of the floorboards 1, 2 is meant a side facing away  
15 from the sub-floor 10 when the floorboards are installed. However, during production, the upper surface 15, 17 may not necessary facing upwards but may temporarily facing downwards.

It is contemplated that there are numerous modifications of the embodiments described herein, which are still within the scope of the invention  
20 as defined by the appended claims.

It is further contemplated that the calibrating groove 11 may have any shape. For example, the calibrating groove may be U-shaped as shown in Figs. 2-3. Furthermore, the bottom surface 19 of the calibrating groove 11 may be inclined, as shown in Figs. 4-5.

Furthermore, it is contemplated that the mechanical locking system described above with reference to Figs. 2-6 may be used without the calibrating groove 11. For example, floorboards having a mechanical locking system may be provided, comprising a locking strip 5 protruding from a first edge 3 of a first floorboard 1. The locking strip 5 may be provided with a locking element 6  
25 configured to cooperate with a locking groove 7 at a lower side 18 of a second edge 4 of a second floorboard 2 for locking the first edge 3 and the second edge 4 in the horizontal direction. The locking element 6 comprises a curved outer upper part 30. The locking groove 7 may have a curved outer lower part 31.  
30

**Claims**

1. Floorboards provided with a mechanical locking system comprising a locking strip (5) protruding from a first edge (3) of a first floorboard (1), wherein the locking strip (5) is provided with a locking element (6) configured to cooperate with a locking groove (7) at a lower side (18) of a second edge (4) of a second floorboard (2) for locking the first edge (3) and the second edge (4) in a horizontal direction, the first edge (3) and the second edge (4) are configured to be assembled by a vertical downward motion of the second edge (4) towards the first edge (3), characterized in that said second edge (4) is provided with a calibrating groove (11) adjacent said locking groove (7).
2. The floorboards as claimed in claim 1, wherein at least said second edge (4) is flexible.
3. The floorboards as claimed in claim 1 or 2, wherein at least the second floorboard (2) is flexible.
4. The floorboards as claimed in any one of the preceding claims, wherein at least the second floorboard (2) comprises a plastic material, preferably a thermoplastic material, or an elastomer.
5. The floorboards as claimed in any one of the preceding claims, wherein a core of the second floorboard (2) comprises a plastic material, preferably a thermoplastic material, or an elastomer.
6. The floorboards as claimed in any one of the preceding claims, wherein the calibrating groove (11) is open towards the locking groove (7).
7. The floorboards as claimed in any one of the preceding claims, wherein a depth of the calibrating groove (11) substantially equals or exceeds a mean variation in thickness between the floorboards.
8. The floorboards as claimed in any one of the preceding claims, wherein a depth of the calibrating groove (11) substantially equals a difference

in thickness between the first floorboard (1) and the second floorboard (2).

9. The floorboards as claimed in any one of the preceding claims, wherein the calibrating groove (11) is arranged at the lower side (18) of the second floorboard (2).  
5

10. The floorboards as claimed in any one of the preceding claims, wherein the locking element (6) has a curved outer upper part (30).

11. The floorboards as claimed in any one of the preceding claims, wherein the first edge (3) or the second edge (4) is provided with a tongue (8; 13) configured to cooperate with a tongue groove (9; 14) at the other of the first (3) or the second edge (4) for locking of the first edge (3) and the second edge (4) in a vertical direction.  
10  
15

12. The floorboards as claimed in claim 11, wherein the tongue (13) is formed of the same material as the first edge (3) or the second edge (4).

13. The floorboards as claimed in claim 12, wherein the tongue (13) is provided at the second edge (4) and extends vertically downward from an upper side (17) of the second floorboard (2).  
20

14. The floorboards as claimed in claim 13, wherein a width of the tongue (13) increases with a distance from the upper side (17) of the second floorboard (2).  
25

15. The floorboards as claimed in claim 11, wherein the tongue is a displaceable tongue (8) arranged in a displacement groove (12).

16. A method for producing a mechanical locking system at edges (3, 4, 23, 24) of a first floorboard (1) and a second floorboard (2), wherein the method comprises the step of:  
30

providing the first floorboard (1) and the second floorboard (2), wherein the first floorboard (1) has a first thickness and the second floorboard (2) has a second thickness different from the first thickness,  
35

forming a locking groove (7, 27) at a lower side (16, 18) of a second edge

(4, 24) of the first floorboard (1) and the second floorboard (2), and  
forming a calibrating groove (11) at the lower side (16; 18) of the second  
edge (4, 24) of at least one of the first floorboard (1) and the second floorboard  
(2) with a tool, wherein said tool is positioned at a fixed position relative an  
5 upper side (15, 17) of the first floorboard (1) and the second floorboard (2).

17. The method as claimed in claim 16, further comprising positioning  
a bottom surface (19) of the calibrating groove (11) at a fixed distance from the  
upper side (15, 17) of the first floorboard (1) and the second floorboard (2).

10

18. The method as claimed in claim 16, wherein the bottom surface  
(19) of the calibrating groove (11) is positioned such that a depth of the  
calibrating groove (11) substantially equals or exceeds a mean variation in  
thickness between the first floorboard (1) and the second floorboard (2).

15

19. The method as claimed in claim 16, wherein the bottom surface  
(19) of the calibrating groove (11) is positioned such that a depth of the  
calibrating groove (11) substantially equals a difference in thickness between  
the first floorboard (1) and the second floorboard (2).

20

20. The method as claimed in any one of claims 16-19, wherein the  
locking groove and the calibrating groove are formed adjacent each other.

21. The method as claimed in any one of claims 16-20, wherein the  
25 calibrating groove (11) is open towards the locking groove (7, 27).

22. The method as claimed in any one of claims 16-21, further  
comprising forming a locking strip (5, 25) provided with a locking element (6,  
26) at a first edge (3, 23) of the first floorboard (1) and the second floorboard  
30 (2), wherein the locking element (6, 26) is configured to cooperate with the  
locking groove (7, 27).

23. The method as claimed in any one of claims 16-22, further  
comprising forming a tongue groove (9, 29; 14) at the first edge (3) or the  
35 second edge (4) of the first floorboard (1) and the second floorboard (2), and  
providing a tongue (8; 13) at the other of the first edge (3) and the second edge

(4) of the first floorboard (1) and the second floorboard (2), wherein tongue (8; 13) is configured to cooperate with the tongue groove (9, 29; 14).

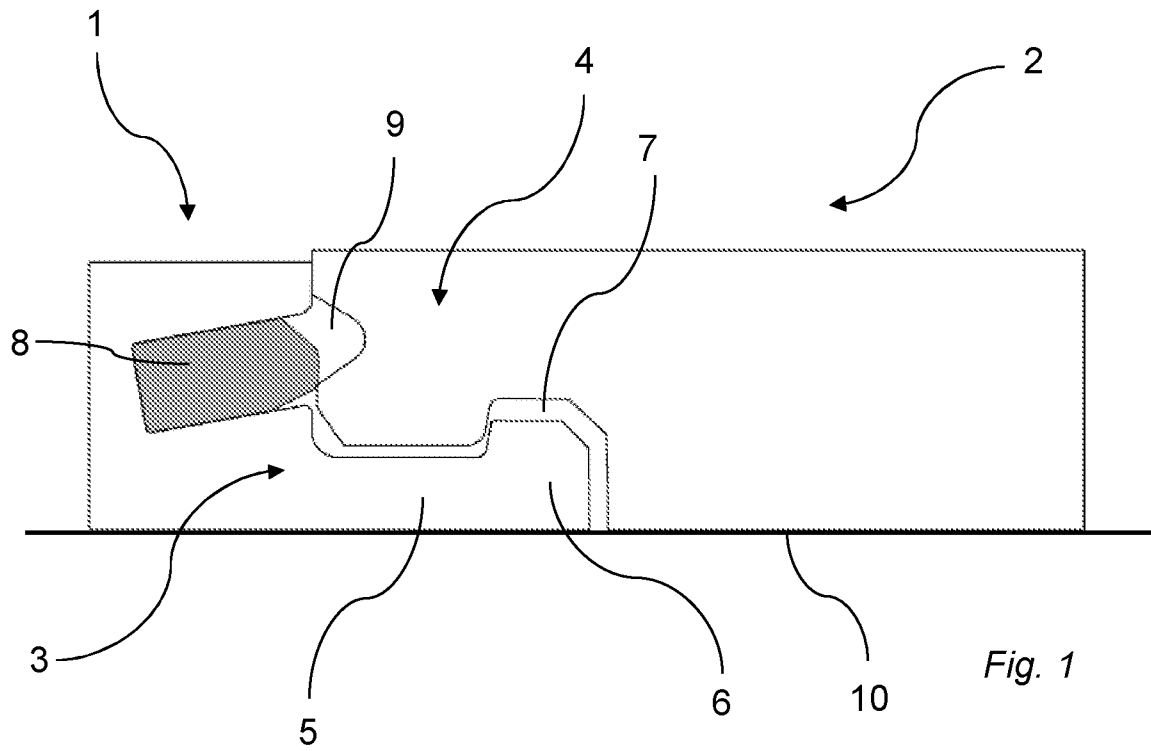

KNOWN ART



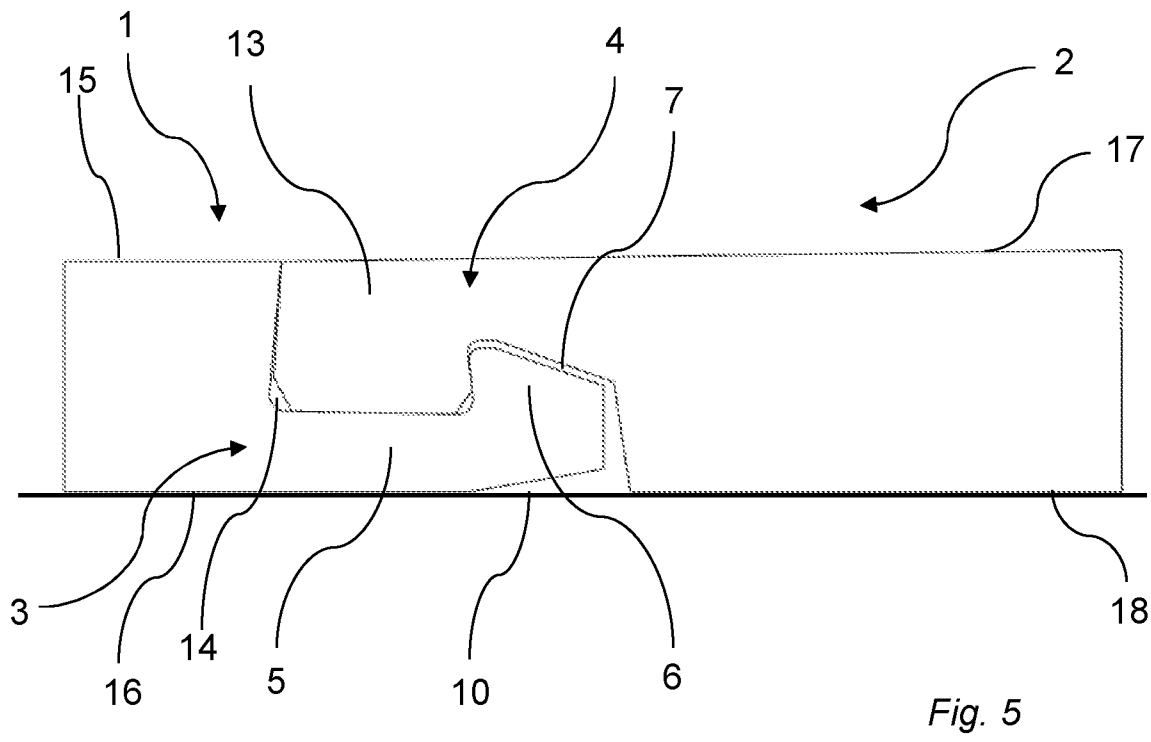
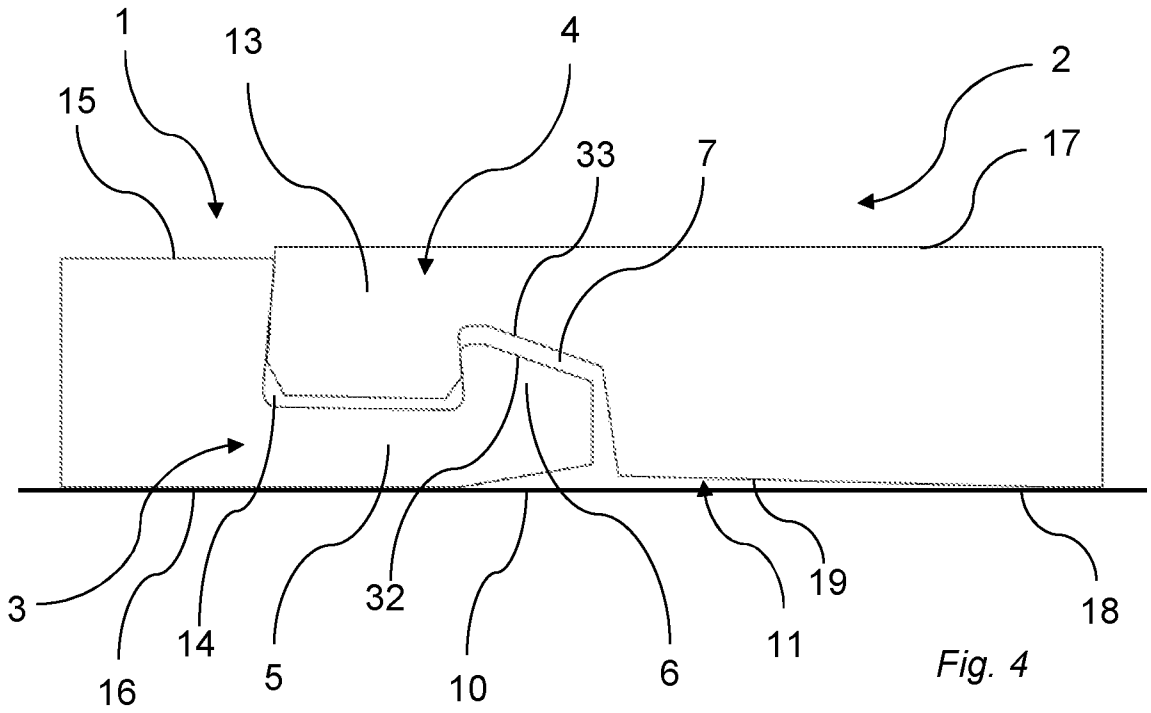

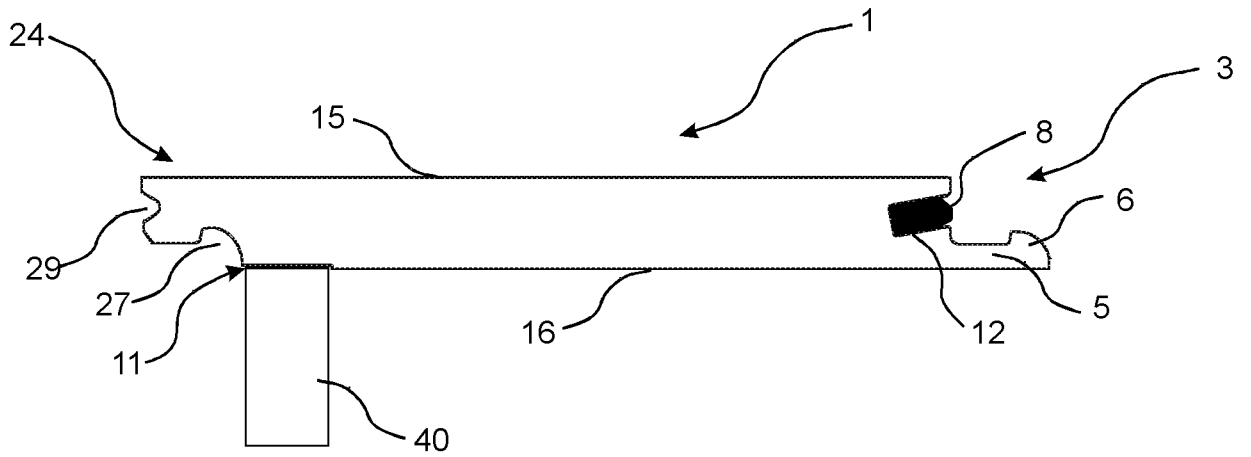

Fig. 6a

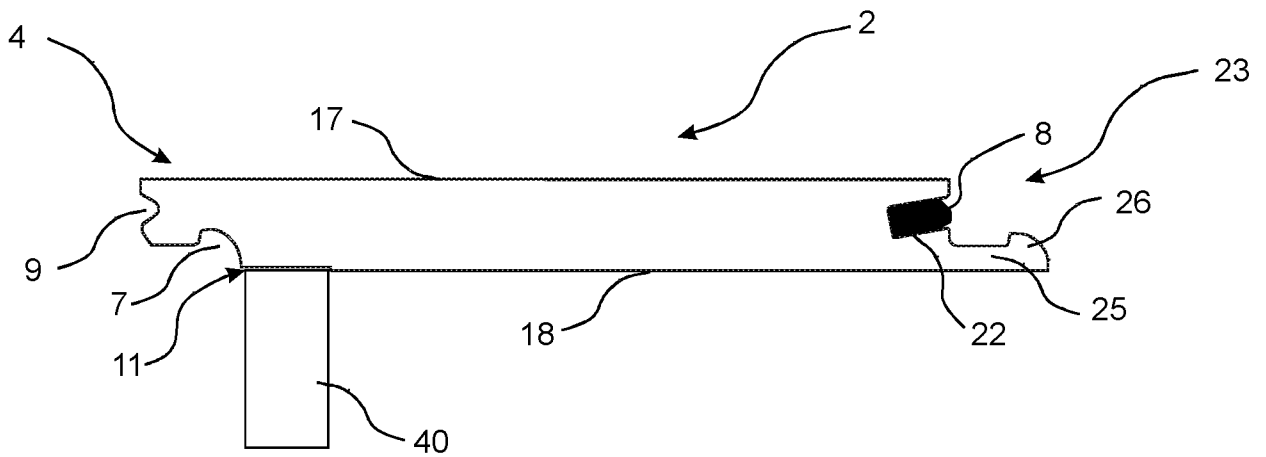

Fig. 6b

## INTERNATIONAL SEARCH REPORT

International application No.  
PCT/SE201 4/050360

## A. CLASSIFICATION OF SUBJECT MATTER

IPC: see extra sheet

According to International Patent Classification (IPC) or to both national classification and IPC

## B. FIELDS SEARCHED

Minimum documentation searched (classification system followed by classification symbols)

IPC: E04F

Documentation searched other than minimum documentation to the extent that such documents are included in the fields searched

SE, DK, FI, NO classes as above

Electronic data base consulted during the international search (name of data base and, where practicable, search terms used)

EPO-Internal, PAJ, WPI data

## C. DOCUMENTS CONSIDERED TO BE RELEVANT

Category*	Citation of document, with indication, where appropriate, of the relevant passages	Relevant to claim No.
A	EP 2339092 A 1 (FLOORING IND LTD SARL), 29 June 201 1 (201 1-06-29); abstract; paragraphs [0004], [0007], [0061 ]; figures 13,14 --	1-23
A	WO 2009061 279 A 1 (VAELINGE INNOVATION AB ET AL), 14 May 2009 (2009-05-1 4); abstract; page 2 1, line 12 - line 2 1; page 23, line 2 1 - line 27; figures 1a-c --	1-23
A	US 6647690 B 1 (MARTENSSON GORAN), 18 November 2003 (2003-1 1-18); abstract; column 5, line 26 - line 35; figure 5 --	1-23

 Further documents are listed in the continuation of Box C. See patent family annex..

\* Special categories of cited documents:

"A" document defining the general state of the art which is not considered to be of particular relevance

"E" earlier application or patent but published on or after the international filing date

"L" document which may throw doubts on priority claim(s) or which is cited to establish the publication date of another citation or other special reason (as specified)

"O" document referring to an oral disclosure, use, exhibition or other means

"P" document published prior to the international filing date but later than the priority date claimed

"T" later document published after the international filing date or priority date and not in conflict with the application but cited to understand the principle or theory underlying the invention

"X" document of particular relevance; the claimed invention cannot be considered novel or cannot be considered to involve an inventive step when the document is taken alone

"Y" document of particular relevance; the claimed invention cannot be considered to involve an inventive step when the document is combined with one or more other such documents, such combination being obvious to a person skilled in the art

"&amp;" document member of the same patent family

Date of the actual completion of the international search

02-06-2014

Date of mailing of the international search report

03-06-2014

Name and mailing address of the ISA/SE  
Patent- och registreringsverket  
Box 5055  
S-102 42 STOCKHOLM  
Facsimile No. + 46 8 666 02 86Authorized officer  
Örjan Nylund

Telephone No. + 46 8 782 25 00

**INTERNATIONAL SEARCH REPORT**

International application No.  
PCT/SE201 4/050360

C (Continuation). DOCUMENTS CONSIDERED TO BE RELEVANT

Category*	Citation of document, with indication, where appropriate, of the relevant passages	Relevant to claim No.
A	US 3538665 A 1 (GOHNER PAUL), 10 November 1970 (1970-11-10); column 4, line 1 - line 18; figure 6 -- -----	1-23

**Continuation of:** second sheet  
**International Patent Classification (IPC)**  
***E04F 75/02*** (2006.01 )

INTERNATIONAL SEARCH REPORT  
Information on patent family members

International application No.  
PCT/SE201 4/050360

EP	2339092	A 1	29/06/201 1	CA	2784227	A 1	30/06/201 1
				CN	102753772	A	24/1 0/201 2
				EP	2516768	A2	31/1 0/201 2
				US	201 20266555	A 1	25/1 0/201 2
				WO	201 107731 1	A3	18/08/201 1
WO	2009061 279	A 1	14/05/2009	CN	10191 0528	B	25/07/201 2
				EP	2235286	A 1	06/1 0/201 0
				US	8499521	B2	06/08/201 3
				US	201 00293879	A 1	25/1 1/201 0
US	6647690	B 1	18/11/2003	AT	304098	T	15/09/2005
				AT	499493	T	15/03/201 1
				AT	433527	T	15/06/2009
				AU	6493099	A	29/08/2000
				BR	9917057	A	27/1 1/2001
				CA	2360414	A 1	17/08/2000
				CN	1107780	C	07/05/2003
				CN	1334893	A	06/02/2002
				CZ	293258	B6	17/03/2004
				CZ	2001 2848	A3	13/02/2002
				DE	29924454	U 1	28/05/2003
				DE	699271 84	T2	14/06/2006
				DE	69943223	D 1	07/04/201 1
				DE	69940983	D 1	23/07/2009
				DK	1304427	T3	14/09/2009
				DK	1159497	T3	14/1 1/2005
				DK	1394336	T3	06/06/201 1
				EP	2267239	A3	27/04/201 1
				ES	22451 26	T3	16/1 2/2005
				ES	2361 736	T3	21/06/201 1
				ES	2328341	T3	12/1 1/2009
				HU	0 105225	A2	29/04/2002
				HU	2241 0 1	B 1	30/05/2005
				PL	208749	B 1	30/06/201 1
				PL	349221	A 1	01/07/2002
				RU	2239690	C2	10/1 1/2004
				SE	9900432	A	11/08/2000
				SE	5 15789	C2	08/1 0/2001
				TR	2001 02258	T2	21/1 2/2001
				US	6854235	B2	15/02/2005
				US	20040068954	A 1	15/04/2004
				WO	0047841	A 1	17/08/2000
US	3538665	A 1	10/1 1/1 970	NONE			