



- (51) International Patent Classification: *G01N 23/18* (2006.01)
- (21) International Application Number: PCT/US2017/022620
- (22) International Filing Date: 16 March 2017 (16.03.2017)
- (25) Filing Language: English
- (26) Publication Language: English
- (30) Priority Data: 62/310,427 18 March 2016 (18.03.2016) US
- (71) Applicant (for US only): **SCHLUMBERGER TECHNOLOGY CORPORATION** [US/US]; 300 Schlumberger Drive, Sugar Land, Texas 77478 (US).
- (71) Applicant (for CA only): **SCHLUMBERGER CANADA LIMITED** [CA/CA]; 125 - 9 Avenue SE, Calgary, Alberta T2G 0P6 (CA).
- (71) Applicant (for FR only): **SERVICES PETROLIERS SCHLUMBERGER** [FR/FR]; 42 rue Saint Dominique, 75007 Paris (FR).
- (71) Applicant (for all designated States except CA, FR, US): **SCHLUMBERGER TECHNOLOGY B.V.** [NL/NL]; Parkstraat 83-89, NL-2514 JG The Hague (NL).
- (72) Inventors: **LIU, Zhanke**; 1318 Cedar Terrace Court, Sugar Land, Texas 77479 (US). **YANG, Linyuan**; 1800 Austin Parkway, #1802, Sugar Land, Texas 77479 (US). **CAMPBELL, Gregory**; 5519 Maverick Point Lane, Katy, 77494 (US). **MARATHE, Rujuta**; 15000 W Airport Blvd, #1623, Sugar Land, Texas 77498 (US).
- (74) Agents: **FLYNN, Michael** et al.; 10001 Richmond Avenue, IP Administration Center of Excellence, Room 4720, Houston, Texas 77042 (US).
- (81) Designated States (unless otherwise indicated, for every kind of national protection available): AE, AG, AL, AM, AO, AT, AU, AZ, BA, BB, BG, BH, BN, BR, BW, BY, BZ, CA, CH, CL, CN, CO, CR, CU, CZ, DE, DJ, DK, DM, DO, DZ, EC, EE, EG, ES, FI, GB, GD, GE, GH, GM, GT, HN, HR, HU, ID, IL, IN, IR, IS, JP, KE, KG, KH, KN, KP, KR, KW, KZ, LA, LC, LK, LR, LS, LU, LY, MA, MD, ME, MG, MK, MN, MW, MX, MY, MZ, NA, NG, NI, NO, NZ, OM, PA, PE, PG, PH, PL, PT, QA, RO, RS,

[Continued on next page]

(54) Title: TRACKING AND ESTIMATING TUBING FATIGUE IN CYCLES TO FAILURE CONSIDERING NON-DESTRUCTIVE EVALUATION OF TUBING DEFECTS

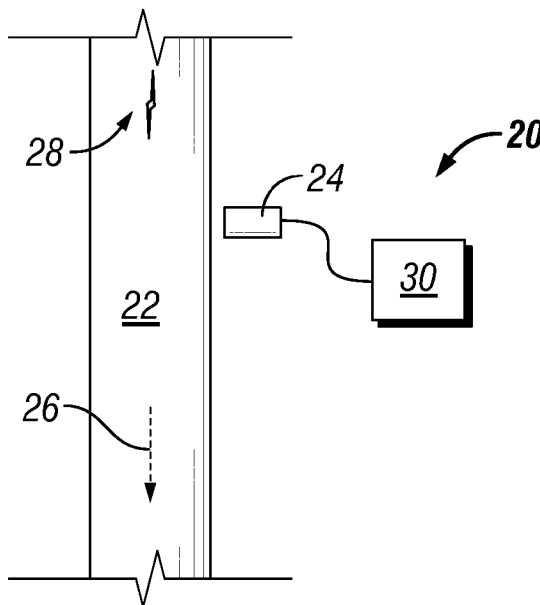

FIG. 1

(57) Abstract: A technique facilitates tracking and assessing a fatigue life of a tubing string utilizing, for example, estimation of cycles to failure when used in a wellbore operation. The technique may comprise initially determining a fatigue life of a tubing string. Additionally, the technique comprises utilizing a sensing device, e.g. a magnetic flux leakage (MFL) device, to monitor the tubing string. When an anomaly, e.g. a new defect, is detected by the sensing device, a new fatigue life of the tubing string is determined based on the change. The new fatigue life may be used to estimate a fatigue life in terms of cycles to failure.

RU, RW, SA, SC, SD, SE, SG, SK, SL, SM, ST, SV, SY,
TH, TJ, TM, TN, TR, TT, TZ, UA, UG, US, UZ, VC,
VN, ZA, ZM, ZW.

DK, EE, ES, FI, FR, GB, GR, HR, HU, IE, IS, IT, LT,
LU, LV, MC, MK, MT, NL, NO, PL, PT, RO, RS, SE,
SI, SK, SM, TR), OAPI (BF, BJ, CF, CG, CI, CM, GA,
GN, GQ, GW, KM, ML, MR, NE, SN, TD, TG).

(84) Designated States (*unless otherwise indicated, for every kind of regional protection available*): ARIPO (BW, GH, GM, KE, LR, LS, MW, MZ, NA, RW, SD, SL, ST, SZ, TZ, UG, ZM, ZW), Eurasian (AM, AZ, BY, KG, KZ, RU, TJ, TM), European (AL, AT, BE, BG, CH, CY, CZ, DE,

Published:

— *with international search report (Art. 21(3))*

**TRACKING AND ESTIMATING TUBING FATIGUE IN CYCLES TO FAILURE
CONSIDERING NON-DESTRUCTIVE EVALUATION OF TUBING DEFECTS**

CROSS-REFERENCE TO RELATED APPLICATION

[0001] The present document is based on and claims priority to U.S. Provisional Application Serial No.: 62/310,427, filed March 18, 2016, which is incorporated herein by reference in its entirety.

BACKGROUND

[0002] Coiled tubing technology has been used in an expanding range of applications since its introduction to the oil industry in the 1960s. The wide array of tools and technologies that can be used in cooperation with coiled tubing and the ability of coiled tubing to pass through completion tubulars makes the technology very versatile. A coiled tubing system may include surface pumping facilities, a coiled tubing string mounted on a reel, an injector head or other mechanism to convey the coiled tubing into and out of the wellbore, and a surface control apparatus at the wellhead. The coiled tubing may be deployed in wellbores to facilitate performance of well treatment and/or well intervention operations, e.g. operations comprising hydraulic fracturing, matrix acidizing, milling, perforating, coiled tubing drilling, or other downhole operations.

SUMMARY

[0003] In general, the present disclosure provides a methodology and system for tracking and assessing a fatigue life of a tubing string utilizing, for example, estimation of

cycles to failure when used in a wellbore operation. According to an embodiment, the technique comprises determining a fatigue life of a tubing string, e.g. a coiled tubing string, and utilizing a sensing device, e.g. a magnetic flux leakage (MFL) device, to monitor the tubing string. When an anomaly, e.g. a new defect, is detected by the sensing device, a new fatigue life of the tubing string is determined based on the anomaly. The new fatigue life may be used to estimate a fatigue life in terms of cycles to failure.

BRIEF DESCRIPTION OF THE DRAWINGS

[0004] Certain embodiments will hereafter be described with reference to the accompanying drawings, wherein like reference numerals denote like elements. It should be understood, however, that the accompanying figures illustrate various implementations described herein and are not meant to limit the scope of various technologies described herein, and:

[0005] Figure 1 is a schematic illustration of an example of a pipe defect assessment system for evaluating pipe, e.g. coiled tubing, according to an embodiment of the disclosure;

[0006] Figure 2 is a schematic illustration of a processor-based system for evaluating sensor data in combination with stored historical data, thus enabling accurate estimation of cycles to failure, according to an embodiment of the disclosure;

[0007] Figure 3 is a graphical representation illustrating data regarding fatigue life of a pipe versus depth of the pipe, according to an embodiment of the disclosure;

[0008] Figure 4 is a graphical representation illustrating data regarding nominal wall thickness of a pipe versus depth of the pipe, according to an embodiment of the disclosure;

[0009] Figure 5 is a graphical representation illustrating data regarding cycles to failure versus depth of the pipe, according to an embodiment of the disclosure;

[0010] Figure 6 is another graphical representation illustrating data regarding cycles to failure versus depth of the pipe, according to an embodiment of the disclosure;

[0011] Figure 7 is another graphical representation illustrating data regarding cycles to failure versus depth of the pipe, according to an embodiment of the disclosure;

[0012] Figure 8 is another graphical representation illustrating data regarding cycles to failure versus depth of the pipe, according to an embodiment of the disclosure;

[0013] Figure 9 is a graphical representation illustrating data regarding consumed fatigue life versus depth of the pipe, according to an embodiment of the disclosure;

[0014] Figure 10 is another graphical representation illustrating data regarding fatigue life versus depth of the pipe, according to an embodiment of the disclosure;

[0015] Figure 11 is another graphical representation illustrating data regarding fatigue life versus depth of the pipe, according to an embodiment of the disclosure;

[0016] Figure 12 is another graphical representation illustrating data regarding fatigue life versus depth of the pipe, according to an embodiment of the disclosure;

[0017] Figure 13 is another graphical representation illustrating data regarding fatigue life versus depth of the pipe, according to an embodiment of the disclosure; and

[0018] Figure 14 is a graphical representation illustrating data regarding estimated trips to failure versus depth of the pipe, according to an embodiment of the disclosure.

DETAILED DESCRIPTION

[0019] In the following description, numerous details are set forth to provide an understanding of some illustrative embodiments of the present disclosure. However, it will be understood by those of ordinary skill in the art that the system and/or methodology may be practiced without these details and that numerous variations or modifications from the described embodiments may be possible.

[0020] The disclosure herein generally relates to a methodology and system for tracking and assessing a fatigue life of a pipe string, e.g. a coiled tubing string. According to an embodiment, the technique may be used to provide accurate estimation of cycles to failure, e.g. trips downhole until failure, when the pipe string is used in, for example, a wellbore operation. The technique comprises determining a fatigue life of a coiled tubing string based on historical data which may be stored on a processing device, e.g. a computer, or other suitable device. A sensing device, e.g. a magnetic flux leakage (MFL) device, also is used to monitor the coiled tubing string. When an anomaly, e.g. a new defect, is detected by the sensing device, a new fatigue life of the coiled string is determined based on stored data regarding the anomaly. Data on fatigue life, anomaly type, and updated fatigue life may be processed to determine an accurate estimate of fatigue life in cycles and/or trips to failure. The estimate information may then be output to enable evaluation regarding future use of the pipe string.

[0021] Accordingly, embodiments described herein may be used as a method of tracking coiled tubing fatigue with incorporation of the concept of cycles to failure. This new approach to fatigue tracking provides more direct assessment to end users regarding the fitness of the coiled tubing string for service as compared to traditional methods of percentage fatigue life tracking. Embodiments utilize sensor data, e.g. MFL inspection data, to estimate a reduction in cycles to failure due to anomalies, such as changes which occur to the tubing string. Examples of anomalies which can affect the number of cycles

to failure include localized defects, wall thinning, ballooning, and a variety of other anomalies.

[0022] Referring generally to Figure 1, an example of a pipe tracking system 20 for evaluating pipe 22, e.g. jointed pipe or coiled tubing, is illustrated. It should be noted that the embodiments described herein may be employed in well or non-well related applications. Additionally, the pipe tracking system 20 may comprise a variety of pipe support systems, pipe delivery systems, sensor arrangements, local and/or remote processing systems, data evaluation algorithms, models, and/or other software programs, as well as other components arranged in various configurations depending on the parameters of a pipe damage assessment application.

[0023] In Figure 1, an embodiment of the pipe tracking system 20 is in the form of a coiled tubing tracking system. Additionally, the pipe 22 is illustrated in the form of coiled tubing 22 which moves relative to an appropriate sensor device having a sensor or sensors 24. In embodiments described herein, the sensor or sensors 24 may comprise magnetic flux leakage (MFL) sensors which monitor magnetic flux leakage. The relative movement of coiled tubing 22 is indicated by arrow 26, however some embodiments may be constructed to move the sensor or sensors 24 along a stationary pipe 22. Additionally, both the pipe 22 and the sensor(s) 24 may be moved to cause the relative movement with respect to each other.

[0024] Each sensor 24 may be positioned to monitor for the presence of a magnetic flux leakage signal associated with an anomaly 28, e.g. a defect, and to output sensor data to a data processing system 30. The signals provided by sensor 24 change upon detection of the differing magnetic flux leakage signal associated with the defect 28 or other anomaly. The changes in that sensor data can be processed via data processing system 30 to, for example, quantify defect shape, size, and/or severity which can then be used in combination with other data to estimate a fatigue life, e.g. a cycles to failure, with respect to the coiled tubing or other pipe 22.

[0025] The presence of an anomaly on coiled tubing 22 affects its mechanical integrity by, for example, reducing its tensile load capacity or reducing its pressure containment capacity, thus reducing the number of cycles until failure of the coiled tubing occurs. The cycles to failure may be diminished because the presence of a defect often acts as a stress riser which can lead to development of fatigue cracking in coiled tubing or other pipe. However, changes in wall thickness, ballooning, or other anomalies also can reduce the cycles to failure relative to the determined fatigue life of the coiled tubing without the presence of the anomaly or anomalies.

[0026] By utilizing the sensor or sensors 24, magnetic flux leakage changes may be monitored to determine whether the magnetic flux leakage signal, e.g. MFL signature, begins to indicate characteristics associated with an anomaly able to reduce the cycles to failure. The magnetic flux leakage signal data is relayed from the sensor 24 to the data processing system 30 for evaluation, as described in greater detail below. The sensor(s) 24 may be used at a wellsite or at an off-site facility for testing pipe 22. For example, the sensor(s) 24 may be used in a wellbore operation as coiled tubing 22 is deployed into or retrieved from a wellbore penetrating a subterranean formation.

[0027] In the example illustrated, the sensor or sensors 24 detect magnetic flux leakage but the sensors 24 may be combined with other types of sensors positioned to help detect and analyze an anomaly or anomalies along pipe 22. In some embodiments sensor 24 may comprise a single sensor but sensor 24 also may comprise a plurality of sensors or sensor elements arranged longitudinally and/or circumferentially. In a specific embodiment, sensor 24 comprises a plurality of magnetic flux leakage sensing elements positioned to detect along the circumference of pipe 22 as pipe 22 and sensor(s) 24 are moved relative to each other. Although pipe 22 has been described in the form of coiled tubing which moves relative to the sensor, the pipe 22 may comprise individual pipe joints or other types of pipes which are moved relative to the sensor 24.

[0028] Data obtained by the sensor or sensors 24 is transmitted to processing system 30. The processing system 30 may be located in whole or in part at a well site, at

a well testing facility, and/or at a remote location. After processing data from each sensor 24, the processing system 30 may be used to display or otherwise output results related to the detection and evaluation of magnetic flux leakage signal data corresponding with the one or more anomalies 28. The raw and/or processed data may be sent to other systems and other locations for continued processing, analysis, and/or control operations.

[0029] Referring generally to Figure 2, an example of processing system 30 is illustrated. In this example, processing system 30 is in the form of a computer-based system having a processor 32, such as a central processing unit (CPU). The processor 32 is coupled with sensor or sensors 24 and is operatively employed to intake magnetic flux leakage signal data related to anomalies, e.g. defects, 28 and then to process the data, e.g. run appropriate models and/or algorithms. For example, the data may be processed to find similar stored signal data correlated with specific types of defects 28, e.g. defects of a certain size, type, and/or shape. This data may then be processed to update stored data on fatigue life of the pipe/coiled tubing 22 so as to enable an accurate estimation of cycles to failure.

[0030] Fatigue life data, anomaly data, and other types of data may be stored in a suitable memory 34 which may comprise a single or plural memory devices. In the example illustrated, the processor 32 is operatively coupled with memory 34 as well as with an input device 36 and an output device 38. In some embodiments, the connection between sensors 24 and processing system 30 may be indirect. For example, data from the sensor or sensors 24 may be collected and subsequently downloaded to processing system 30.

[0031] Desired data may be stored in memory 34 and the processor 32 may be used to run selected algorithms/models, e.g. comparisons with stored correlations, via a software module/system 40, e.g. an answer product software module. For example, the software module 40 may be used to process the data collected by sensor(s) 24 in combination with other data stored in memory 34. The memory 34 may comprise a

library 42 used to store a variety of data. The library 42 also may be used to store sensor data obtained via the one or more sensors 24.

[0032] By way of example, the library 42 may comprise a fatigue life library 44 which comprises, for example, historical data on fatigue life for various types of coiled tubing 22 (or other types of pipe), and fatigue life models and associated parameters calibrated against historical fatigue data, without including detrimental effects due to defect 28. The library 42 also may comprise an anomaly library 46 which contains historical data on many types of anomalies which can affect the fatigue life of the pipe/coiled tubing 22. According to an embodiment, the anomaly library 46 may include a pre-established benchmark or defect library for use by processor 32. For example, data on the defects 28 may be stored in anomaly library 46 as well as selected attributes of given defects, e.g. a defect photo and a corresponding magnetic flux leakage signal or “defect signature” representing a specific type of defect 28.

[0033] The library 42 also may comprise a correlation library 48 containing, for example, historical data regarding correlations related to fatigue life with and without a given anomaly/defect 28. The software module 40 is able to use such correlations to determine a new fatigue life upon the occurrence of a given defect or other anomaly 28 which matches stored data in library 42 regarding that type of defect/anomaly. Additionally, the library 42 may comprise a cycles to failure library 50 which contains data based on historical testing. As described in greater detail below, testing is employed to obtain data on remaining pipe/coiled tubing cycles based on, for example, the new fatigue life combined with the type of operation in which the pipe/coiled tubing 22 is utilized.

[0034] Referring generally to Figure 3, a graphical illustration is provided in which a plot of data representing consumed fatigue life of coiled tubing 22 is illustrated versus depth of the coiled tubing 22 as measured from a downhole end of the coiled tubing. This type of data may be stored in, for example, fatigue life library 44. Based on the profile of percentage consumed fatigue life in this example, the coiled tubing 22

appears to be most heavily used (the highest percentage of consumed fatigue life) at a depth interval of around 10,000 feet. However, the percentage fatigue life plot, alone, may not provide end users with sufficient information regarding the expected number of cycles to failure under anticipated operating conditions.

[0035] Additionally, due to model nonlinearity of, for example, the fatigue life library 44, the fatigue life value may not indicate the percentage of remaining cycles to failure. For example, a fatigue life of 50% may not mean the remaining number of cycles is the same number as the consumed number of cycles. Due to model nonlinearity, the remaining number of cycles to reach 100% fatigue life may be a fraction of the consumed number of cycles to reach the fatigue life of 50%. If the coiled tubing 22 is a tapered coiled tubing string, the same level of percentage fatigue life on sections of different wall thicknesses may not be equivalent. For example, 40% consumed fatigue life on a thin wall, e.g. a wall of 0.125 inch thickness, may be more serious than 60% consumed fatigue life on a thicker wall, e.g. a wall of 0.204 inch thickness. Moreover, a fatigue life tracking model relying solely on historical data regarding consumed fatigue life for a given coiled tubing 22 may not be sufficiently accurate in the presence of anomalies, e.g. localized defects 28. It should be noted the examples and specific values provided herein are given for purposes of explanation and should not be construed as limiting.

[0036] Embodiments described herein combine fatigue life data with additional data to provide end users with improved information regarding the number of cycles to failure. The methodology is useful for a variety of tubing, including tapered coiled tubing. Tapered coiled tubing strings are widely used in coiled tubing operations and feature changes in nominal wall thickness values from a downhole end of the coiled tubing 22 to an uphole end of the coiled tubing 22. An example of a coiled tubing wall thickness profile is illustrated in Figure 4 as plotted against depth from a downhole end of the coiled tubing. In this example, the coiled tubing 22 has a plurality of different wall thicknesses, e.g. seven different wall thickness values, and a 20,000 foot span. As illustrated, the wall thickness may transition from 0.156 inches at a downhole end to

0.204 inches at an uphole end within the depth range of approximately 5500 feet to 6500 feet.

[0037] For tapered coiled tubing such as the example illustrated in Figure 4, the baseline consumed fatigue life often is traditionally considered 0% for the entire string when in a new, unused state from the manufacturer. This traditional baseline consumed fatigue life of 0% is determined despite the differences in tubing wall thickness at different depths along the borehole during a coiled tubing operation. Despite the change in wall thickness values in this scenario, the expected remaining fatigue life to be consumed is considered the same, namely 100%, for the entire coiled tubing 22. However, the actual expected number of cycles to failure may vary substantially between the sections of different wall thicknesses. For example, the thicker walled end of the coiled tubing 22 would tend to last many more cycles than the thin walled end under typical operating conditions. This also illustrates the desirability of cycles to failure modeling which provides more direct information to end users compared to the conventional percentage fatigue life modeling.

[0038] By combining fatigue life data with anomaly data, e.g. data regarding changes in fatigue life due to different wall thicknesses, a more accurate estimation of the actual fatigue cycle limits may be provided. For example, test data on correlations between wall thickness and reduction in fatigue life as well as the cycles to failure may be stored in libraries 48, 50. An example of such data is illustrated graphically in Figure 5. In the example represented in Figure 5, historical test data for the same type of tapered coiled tubing 22 is plotted to provide cycles to failure versus depth in a common operating scenario, e.g. operating the tapered coiled tubing 22 with 3000 pounds per square inch differential pressure and subjecting the coiled tubing to a 72 inch bending radius. As indicated by this data, the cycles to failure for the thick walled end is greater than the cycles to failure for the thin walled end under the same common bending radius and differential pressure. This indicates the thick walled end may be able to sustain many more fatigue cycles than the thin walled end. This type of historical test data may be collected in library 42 and used by software module 40 to provide an accurate estimate of

the cycles to failure. The estimate may be output to the computer display or other output device 38.

[0039] In Figure 6, results of employing the methodology for estimating cycles to failure are illustrated. The results showing cycles to failure in Figure 6 are calculated by initially determining an existing level of consumed fatigue life for a given tubing 22, as represented in Figure 3. Referring again to Figure 6, it should be noted that the first approximately 5000 feet of coiled tubing 22 on the downhole end may be more susceptible to failure as indicated by the much lower number of remaining cycles to failure. Such improved information is not available from methods of coiled tubing fatigue tracking relying solely on the consumed fatigue life data of coiled tubing without anomalies (see data represented in Figure 3).

[0040] The anomalies 28 which effectively change the fatigue life of the tubing 22 may be in many different forms. By way of example, the coiled tubing 22 or other pipe may be exposed to anomalies in the form of damaging factors, such as mechanical defects, corrosion, and/or bending-straightening cycles. These damaging factors may lead to localized metal loss which can reduce the life expectancy of the coiled tubing 22. The sensor devices 24, e.g. magnetic flux leakage inspection devices, can be used to reliably detect such localized defects. The correlation library 48 may comprise various correlations, e.g. scaling correlations, between the MFL signals and percentage fatigue life reduction. By using such correlations in the methodology described herein, e.g. by combining such correlations with data from the cycles to failure library 50, the reduction in cycles to failure due to the localized effects may be accurately evaluated and output to the desired output device 38.

[0041] By using software module 40 to process the combined data from libraries 44, 46, 48, 50, a more precise estimation of cycles to failure may be provided as compared to using solely the data related to fatigue life of pipe without anomalies 28. In Figure 7, data is provided graphically via plots 52, 54 in the form of plot 54 of depth versus cycles to failure for coiled tubing 22 in which defects/anomalies 28 are not

considered. The figure also contains plot 52 illustrating an improved prediction of cycles to failure versus depth for coiled tubing 22 in which the defect/anomalies 28 are considered. For this example, it should be noted the coiled tubing 22 at around 10,000 feet may be more susceptible to failure. In this case, the increased susceptibility to failure is due to a group of mechanical defects 28 which reduces the expected number of cycles to failure.

[0042] In addition to localized defects, other anomalies 28 may lead to a reduction in coiled tubing fatigue resistance. Such anomalies 28 may include wall thinning due to acid exposure, abrasion, or other factors. The anomalies 28 also may include ballooning of the coiled tubing 22 due to cyclic operations under high pressure. By using the MFL devices 24 or other suitable sensors, the occurrence of such anomalies or changes in such anomalies may be monitored in real time. For example, the MFL sensors 24 may be used to provide real-time, accurate monitoring of wall thicknesses and diameter measurements so that the impact of wall thinning and diameter ballooning may be added to the anomaly library 46 so as to facilitate predictions of cycles to failure. Figure 8 provides an example in which the results are graphically illustrated. In this example, a first plot 56 illustrates the results when the nominal values of wall thickness and coiled tubing diameter are used, and a second plot 58 corresponds with results when the actual measured values of wall thicknesses and diameter are used. By using the MFL sensors 24 to track the anomalies 28, e.g. wall thinning and/or ballooning, improved prediction of cycles to failure may be achieved as illustrated graphically.

[0043] The software module 40 may comprise various models or algorithms for utilizing the data collected and stored in library 42. For example, the software module 40 may comprise a data matching algorithm which matches the appropriate historical data from sub libraries 44, 46, 48 and 50. In some embodiments, the software module 40 may incorporate fatigue life thresholds and trips-to-failure modeling. These various techniques may be used to provide cycles to failure assessments for direct evaluation of fitness for service with respect to a given coiled tubing or other type of pipe 22.

[0044] Initial fatigue life assessment may be determined and stored in library 42 according to established models for fatigue life tracking which consider loading history, e.g. pressure and bending radius, and tubing properties, e.g. diameter, wall thickness, and material grade. As described above, the consumed fatigue life theoretically reaches 100% before failure occurs but in real world operations the failure often occurs prior to reaching the 100% fatigue life due to anomalies 28. The methodologies described herein may be used to provide a rigorous and accurate way of setting fatigue life threshold values which account for the effects of anomalies 28, e.g. localized defects.

[0045] According to an embodiment, a methodology for setting accurate threshold values for fatigue life is based on non-destructive evaluation of the pipe/coiled tubing 22. As described above, magnetic flux leakage sensors 24 may be used to obtain measurements for use in a non-destructive evaluation method based on established quantitative relationships between MFL measurements and a fatigue life ratio of specific defects 28. This fatigue life ratio may be defined as the fraction of total cycles to failure when a defect exists compared to when the defect does not exist. By using this quantitative correlation (which may be stored in correlation library 48), the threshold value of fatigue life may be determined at the place of localized defects.

[0046] An example of the effects of the localized defect 28 is illustrated graphically in Figure 9. In the illustrated graph, the graph line 60 indicates the consumed fatigue life versus depth during deployment of coiled tubing 22 without defects 28. By way of example, the fatigue life for a given defect-free pipe/coiled tubing 22 may be stored in fatigue life library 44. A dot 62 represents a threshold value that the fatigue life should not exceed at a depth of around 5000 feet where a localized defect 28 exists. It should be noted this threshold value is much lower than 100% due to the detrimental effects of localized defect 28 as determined by the stored correlation relationships between MFL measurements and fatigue life ratio in module 40. In addition, it should be noted the value for dot 62 is determined based on the known information regarding the time when the localized defect 28 occurred. If the timing of the occurrence of defect 28 is unknown, then a range of values may be similarly determined for the fatigue life

thresholds, as described immediately below, including worst-case and best-case scenarios.

[0047] In this graphical example, a worst-case scenario has been indicated by a triangle 64 which corresponds to the case where the defect 28 exists from the very beginning. A best-case scenario is indicated by a triangle 66 which corresponds to the case in which the defect 28 occurred very recently. The interval of threshold values between triangles 64 and 66 is based on the fact that the timing of the defect occurrence plays a role in the severity of the effects that result from the defect 28 with respect to coiled tubing fatigue. The earlier the defect 28 occurs, the more impact it has on the life of the coiled tubing 22. Accordingly, the limits of coiled tubing fatigue life may be determined via quantitative evaluation of defect severity based on magnetic flux leakage measurements. In reality, the time when a defect 28 occurs is in general between the very beginning and the very recent job. Thus, the threshold value is in general between the worst-case and the best-case scenarios, as indicated by dot 62, which is between triangle 64 and triangle 66. In some embodiments, the methodology may be implemented via an answer product software package embodied in software module 40 as described in the examples set forth below. The data collected from such testing also may be used in libraries 44, 46, 48, 50 to improve the quality of the historical data and thus the predictive results.

[0048] According to a first example, a coiled tubing string was evaluated with the following details:

OD	2.375 in
Material grade	90-ksi
Wall Thickness	Tapered: - 0.175 in - 0.190 in - 0.204 in - 0.224 in
Milling Date	May, 2015
In-Service Date	February, 2016
End of Service Date	September, 2016
Total Running Feet	783,748 ft with 49 BHAs
Working Drum	Core Diameter: 96 in

	Width: 87 in
Gooseneck Radius	120 in
Operation Type	Coiled Tubing Drilling (CTD)

During the first run-in-hole, the non-destructive evaluation tracking system 20 did not detect an anomaly/defect 28. However, when the coiled tubing string was pulled out of the borehole, three defects 28 were detected respectively near 14,000 feet, 12,000 feet, and 10,000 feet. The defect 28 at 12,000 feet was the defect having the greatest impact. In this particular example, the defect at 12,000 feet was a gouge type defect caused by injector head chain slippage during the first run in hole operation.

[0049] To evaluate the severity of this particular defect 28, the software module 40 was used to employ an answer product software. Based on the processing of data, evaluation results were output via, for example, output device 38 as indicated graphically in Figure 10. In this example, the accumulated baseline fatigue life at the time defect 28 occurred is illustrated by graph line 68. Because the defects 28 occurred while running in hole during the very first run, the baseline fatigue life is near zero except at bias weld locations where fatigue reduction has been applied as illustrated. The impact of the defect 28 on fatigue life was considered by the answer product software of software module 40 and the calculated impact of defect 28 resulted in a dropping of the fatigue life threshold. For this case, the fatigue life threshold is dropped to 40% from the 100% theoretical limit, as represented by the dot 70 indicated at a depth near 12,000 feet. The gap between the graph line 68 and the dot 70 represents the amount of remaining fatigue that can be safely consumed without failure of the coiled tubing 22 at this particular defect 28.

[0050] The answer product software of software module 40 also may be used to track the evolution of specific defects 28, e.g. the defect 28 at a depth near 12,000 feet. In this example, the condition of this particular defect 28 has deteriorated after six months of service in the field. Due to defect deterioration, the quantitative fatigue life threshold is dropped further to about 30% of the previous 40% threshold, as represented by the dot 72 in the graphical illustration of Figure 11. It should be noted the defect 28 is

now located at the depth near 10,800 feet and this is mainly due to coil trimming during deployment.

[0051] Additionally, the baseline fatigue as represented by graph line 74 has grown due to field use compared to line 68 in Figure 10. As illustrated, there is still a gap between the graph line 74 and the dot 72 in Figure 11, but the gap has reduced substantially as compared to the gap in Figure 10. This means the coiled tubing 22 is still suitable for a few additional jobs without failing at this particular defect 28 although the coiled tubing 22 should be continually monitored by the non-destructive evaluation tracking system 20. This case study demonstrates it is feasible to safely extend the useful life of coiled tubing strings even with the presence of a defect, e.g. damage, by using the continued monitoring, inspection, and evaluation of the coiled tubing string enabled by tracking system 20.

[0052] According to a second example, a coiled tubing string was evaluated with the following details:

OD	2.375 in
Material grade	90-ksi
Wall Thickness	Tapered: - 0.156 in - 0.175 in - 0.190 in - 0.204 in
Working Drum	Core Diameter: 115 in Width: 96 in
Gooseneck Radius	100 in
Operation Type	Coiled Tubing Drilling (CTD)

In this example, the answer product software of software module 40 was again used to evaluate the impact of a physical defect 28 on the coiled tubing string 22. Results are shown in Figure 12. It should be noted the test results were achieved at a pressure level of 3000 psi and a gooseneck radius of 100 inches for deployment of the coiled tubing 22. Because of this particular defect 28, the fatigue life threshold was reduced to within 15% for the depth where the defect 28 was located (see dot 76). Because the baseline fatigue

life at that particular depth has already exceeded 13% (see graph line 78), the coiled tubing string 22 was predicted to fail within two typical jobs.

[0053] According to a third example, a coiled tubing string was evaluated with the following details:

OD	2.375 in
Material grade	90-ksi
Wall Thickness	Tapered: - 0.175 in - 0.190 in - 0.204 in - 0.224 in
Milling Date	May, 2015
In-Service Date	January, 2016
End of Service Date	July, 2016
Total Running Feet	855,691 ft with 58 BHAs
Working Drum	Core Diameter: 96 in Width: 87 in
Gooseneck Radius	120 in

In this example, a group of groove/necking type defects 28 were identified at a later stage and tracked via MFL sensors 24 of tracking system 20. The software module 40, e.g. answer product software, of processing system 30 was used by the non-destructive evaluation tracking system 20 to quantify the impact of such defect 20 on the integrity of the coiled tubing 22. The system 20 output results to output device 38 and those results are illustrated graphically in Figure 13.

[0054] It should be noted the test results were obtained while subjecting the coiled tubing 22 to a pressure level of 3000 psi and a gooseneck radius of 120 inches. The results indicate a reduced fatigue life threshold, as represented by dots 80, which is fairly close to the existing baseline fatigue life indicated by graph line 82. These results indicate the coiled tubing 22 is near the end of its useful life. Consequently, appropriate decisions may be made such as withdrawal of the coiled tubing from service based on the system evaluation results. The noninvasive tracking system 20 enables monitoring,

inspection, and evaluation so as to enable withdrawal of the coiled tubing 22 before a costly failure occurs.

[0055] In some embodiments, the software module 40 may be used to estimate cycles to failure based on modeling which assumes the coiled tubing 22 is fatigued against a constant bending radius. However, the coiled tubing 22 may go through varying bending radii depending on the depth of each section of the coiled tubing. For example, the closer the coiled tubing 22 is to the center of the drum/reel on which it is coiled, the smaller the bending radius. Additionally, for each complete trip downhole (as the coiled tubing is moved into and out of the service well), the coiled tubing goes through two complete bending cycles on the gooseneck and one complete cycle on the coiled tubing drum. Based on such facts, the model carried out by processing system 30 may be extended to provide cycles to failure estimates in the form of a quantitative estimation of trips to failure, as indicated graphically in Figure 14.

[0056] Referring again to Figure 14, different estimates of trips to failure are provided graphically for different scenarios and such results may be output to, for example, output device 38. In this example, a graph line 84 represents the model estimation of trips to failure based on new coiled tubing with 0% consumed fatigue life and without localized defects. Such estimation utilizes the fatigue life model built in system/module 40 and is based on the provided operating condition parameters, including the coiled tubing information (e.g. depth, diameter, wall thickness, grade), the corresponding reel geometries (e.g. inside reel diameters, reel width), coiled tubing gooseneck radius, and the typical circulating pressure level. A graph line 86 represents the model estimation of used coiled tubing considering accumulated fatigue life without the existence of localized anomalies, e.g. without localized defects. Such estimation is based on the information used to estimate graph line 84 plus the additional information of the existing/consumed fatigue value at each depth of the coiled tubing.

[0057] In this example, graph lines 88, 90 are utilized and graph line 90 represents the model estimation of used coiled tubing considering accumulated fatigue

life and also considering the existence of localized damages, as detected and processed by system 30 for example. Such estimation utilizes the comprehensive information used to estimate graph line 86 plus the additional information of the MFL measurements by system 30 and the corresponding correlation libraries built into system/module 40 combined with the added assumption that the localized damages were in existence since approximately the time the coiled tubing string was first put into operation. Additionally, graph line 88 represents the model estimation of used coiled tubing considering accumulated fatigue life and also considering the existence of localized damages as detected and processed by system 30 for example. Such estimation utilizes the comprehensive information used to estimate graph line 86, plus additional information of the MFL measurements by system 30 and the corresponding correlation libraries built into system/module 40 combined with the added assumption that the localized damages have occurred on the most recent job. Thus, the tracking and evaluation system 20 may be used to output useful results to an operator so that decisions may be made with respect to continued use of the coiled tubing 22 (or other type of pipe) given various scenarios including the timing of defect occurrence.

[0058] By using processing system 30 to process data regarding anomaly type, the fatigue life accumulation data for the pipe 22, and the number of cycles experienced by the pipe 22 at the time the defect, accurate estimates of the cycles to failure and/or trips to failure can be provided. In some applications, additional data (e.g. depth of defect 28 during usage, pressure and/or bending radius experienced by pipe 22 at the defect 28, wall thickness) can be useful in further enhancing the estimates. The estimates of remaining cycles/trips can be output to, for example, output device 38 for use in determining an appropriate remedial action, such as withdrawal of the pipe, repair of the pipe, or the number of additional operations before such action. As described above, the processing system 30 may further be used in processing data for estimating a threshold value to set a limit for the fatigue life value that should not be exceeded so as to safeguard operations based on defect severity estimation and timing information with respect to defect occurrence.

[0059] The process of estimating may comprise estimating a worst-case threshold value assuming the existence of defects since the very beginning of tubing utilization. Additionally, the process may comprise estimating a best-case threshold value assuming defects occurred very recently. The process also may comprise estimating a worst-case number of trips to failure assuming the presence of defects from the very beginning. Also, the process may comprise estimating the best-case number of trips to failure assuming defects occurred very recently.

[0060] The system and methodologies described herein may be employed in non-well related applications which utilize evaluation of coiled tubing, jointed pipe, and/or other tubing strings. Additionally, processes may employ a variety of sensors, data processing systems, and/or software modules for evaluating sensor data and/or making recommendations. The system may be automated to implement automatic changes to a tubing string operation based on defect data detected and evaluated. In some applications, the operational changes can be made in real time. Additionally, various types of storage databases/libraries may be constructed to accumulate many types of correlations and defect data. By way of example, the library 42 may comprise a defect library which may be automatically updated with defect entries based on defects 28 detected during evaluation of pipes, e.g. coiled tubing. Also, elements of the overall processes described herein may be performed at a variety of times and in various orders during implementation of the processes.

[0061] Although a few embodiments of the system and methodology have been described in detail above, those of ordinary skill in the art will readily appreciate that many modifications are possible without materially departing from the teachings of this disclosure. Accordingly, such modifications are intended to be included within the scope of this disclosure as defined in the claims.

CLAIMS

What is claimed is:

1. A method for tracking and assessing a coiled tubing string, comprising:

determining a fatigue life of the coiled tubing string;
utilizing a magnetic flux leakage (MFL) device to monitor the coiled tubing string;
upon detecting a defect in the coiled tubing string via the MFL device, processing defect data in combination with data on the fatigue life to determine a new fatigue life of the coiled tubing string with the detected defect; and
using the new fatigue life to output an estimate of cycles to failure of the coiled tubing string.
2. The method as recited in claim 1, wherein processing defect data comprises utilizing the type of defect detected as a factor in determining the new fatigue life.
3. The method as recited in claim 1, wherein utilizing comprises utilizing the MFL device to monitor a tapered coiled tubing string.
4. The method as recited in claim 3, wherein using comprises outputting the estimate of cycles to failure for sections of the tapered coiled tubing string along the entire length of the tapered coiled tubing string.
5. The method as recited in claim 1, wherein processing comprises using a software module to select historical data used in determining the new fatigue life.
6. The method as recited in claim 1, wherein using comprises outputting an estimate of remaining trips downhole until failure.

7. The method as recited in claim 1, wherein processing comprises employing a correlation library.
8. The method as recited in claim 1, wherein using comprises estimating a threshold value to set a limit for the fatigue life value that should not be exceeded so as to safeguard operations based on defect severity estimation and timing information with respect to defect occurrence.
9. The method as recited in claim 8, wherein estimating the threshold value comprises estimating a worst-case threshold value assuming the defect existed since the beginning of the use of the coiled tubing string.
10. The method as recited in claim 8, wherein estimating the threshold value comprises estimating a best-case threshold value assuming a recent occurrence of the defect.
11. The method as recited in claim 1, wherein using comprises estimating a worst-case number of trips to failure assuming the defect existed since the beginning of use of the coiled tubing.
12. The method as recited in claim 1, wherein using comprises estimating a best-case number of trips to failure assuming a recent occurrence of the defect.
13. A method, comprising:
 - monitoring coiled tubing to detect the presence of an anomaly in the coiled tubing;
 - providing data regarding the anomaly to a data processing system for comparison to stored historical data;
 - establishing a fatigue life of the coiled tubing without the anomaly;

determining the number of cycles experienced by the coiled tubing at the time the anomaly occurred;

using combined data on the fatigue life, the type of anomaly, and the number of cycles experienced by the coiled tubing at the time the anomaly occurred to estimate a new fatigue life; and

based on the new fatigue life, determining and outputting an estimate of the remaining number of cycles to failure to determine future use of the coiled tubing.

14. The method as recited in claim 13, further comprising continuing to use the coiled tubing a predetermined number of cycles based on the estimate.

15. The method as recited in claim 13, wherein using comprises using at least one MFL sensor to track magnetic flux leakage signals and to detect changes in the magnetic flux leakage signals indicative of the anomaly.

16. The method as recited in claim 13, wherein providing data to the data processing system comprises using magnetic flux leakage signatures to provide data on a type of defect.

17. The method as recited in claim 13, wherein using the combined data comprises using data on borehole depth of the anomaly during use of the coiled tubing and using data on the pressure experienced by a section of the coiled tubing having the anomaly during use of the coiled tubing.

18. A system for estimating tubing life, comprising:

a sensor positioned along a pipe to monitor for a magnetic flux leakage signal associated with an anomaly in the pipe; and

a data processing system which obtains data from the sensor, the data processing system comprising:

a display;

a memory in which historical anomaly data is stored regarding the type of anomaly, the memory also storing fatigue life data regarding fatigue life of the pipe without the anomaly; and

a processor which uses a computer model for combining data from the sensor, historical anomaly data, and fatigue life data to estimate a remaining number of cycles to failure of the pipe.

19. The system as recited in claim 18, wherein the processor also utilizes data on borehole depth of the anomaly during use of the pipe to estimate the remaining number of cycles to failure.

20. The system as recited in claim 19, wherein the computer model is used to output an estimate of trips downhole until failure.

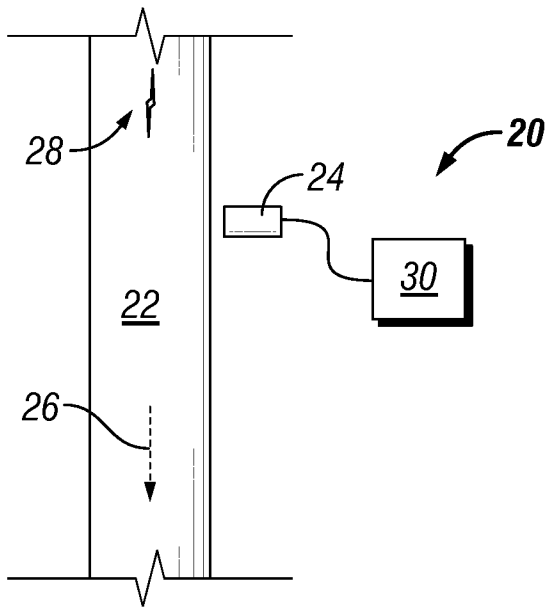

FIG. 1

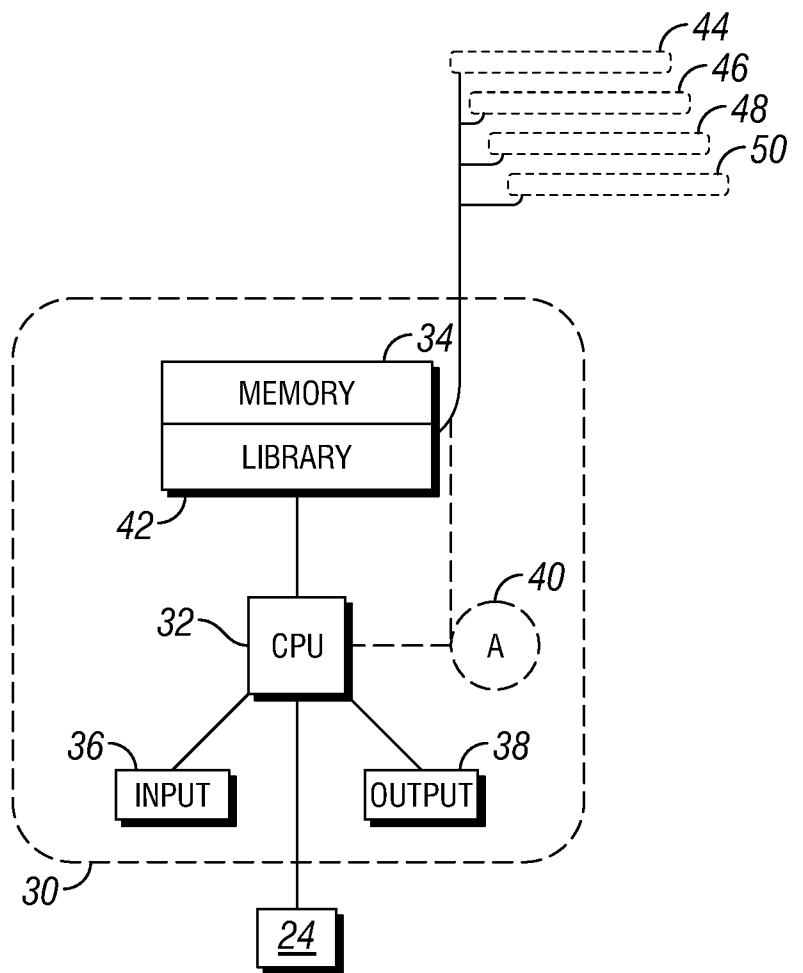

FIG. 2

2/7

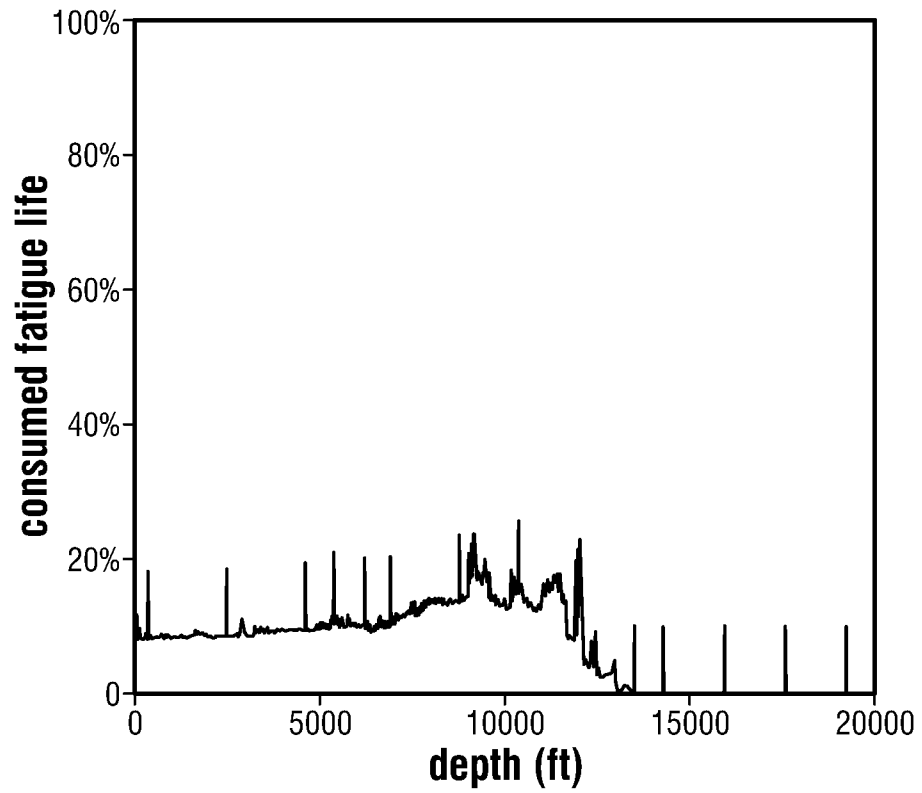

FIG. 3

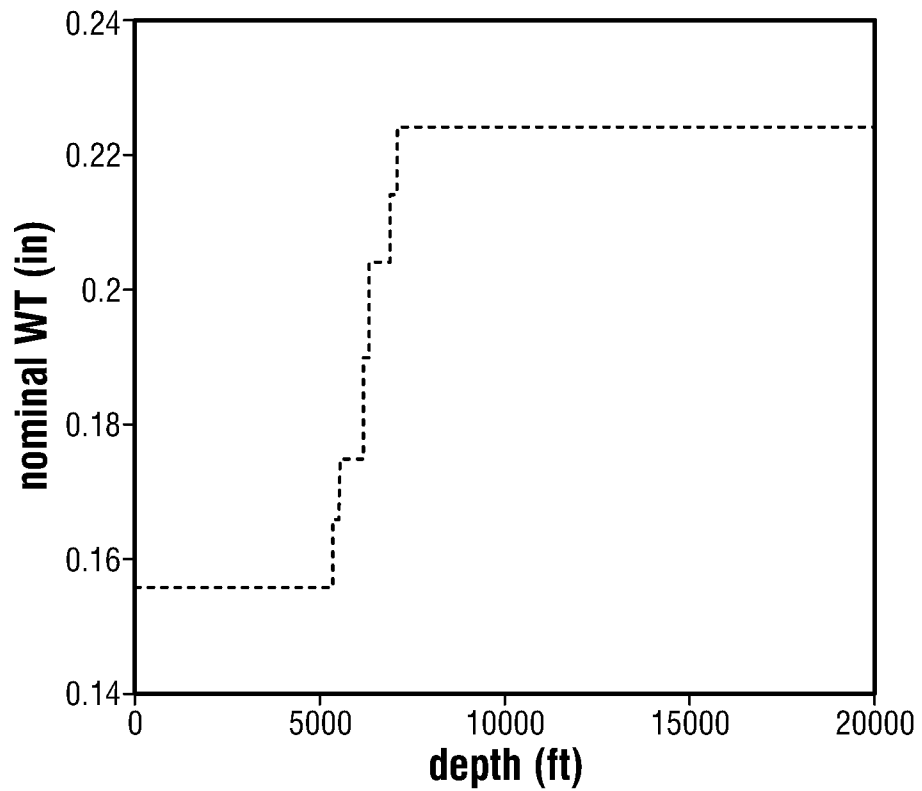

FIG. 4

3/7

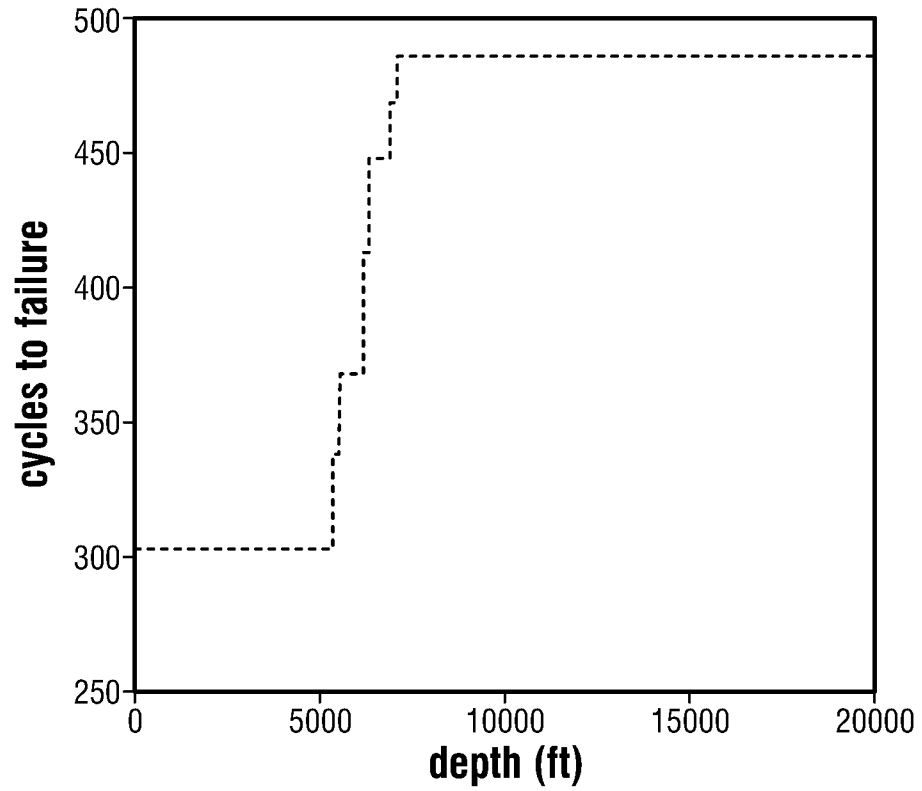

FIG. 5

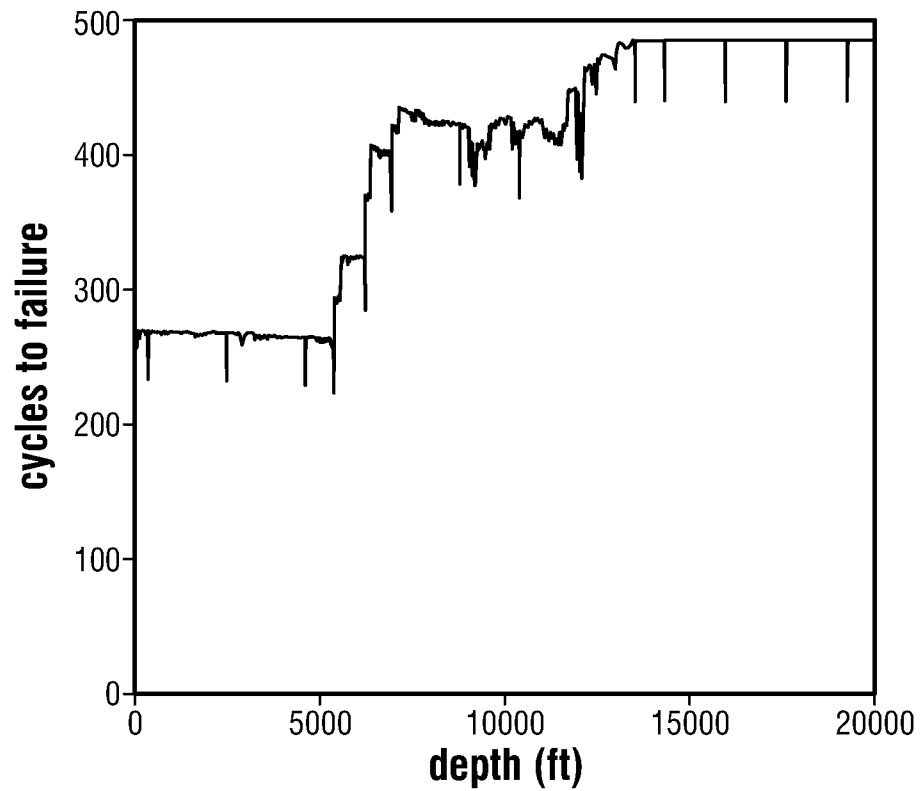

FIG. 6

4/7

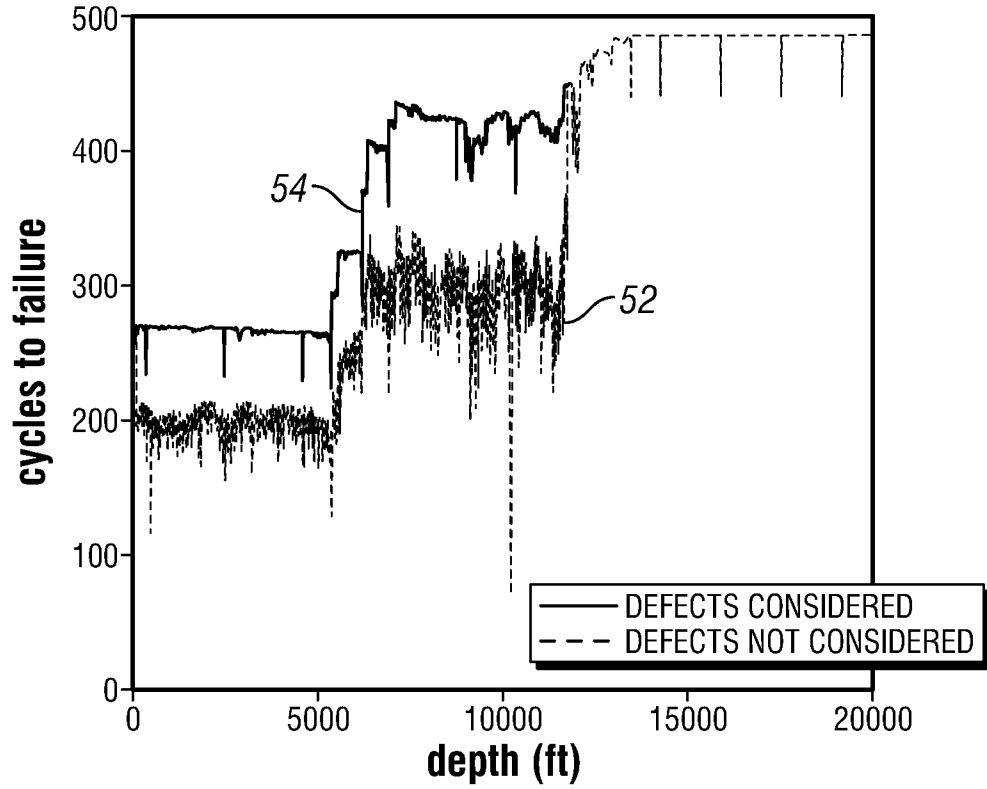

FIG. 7

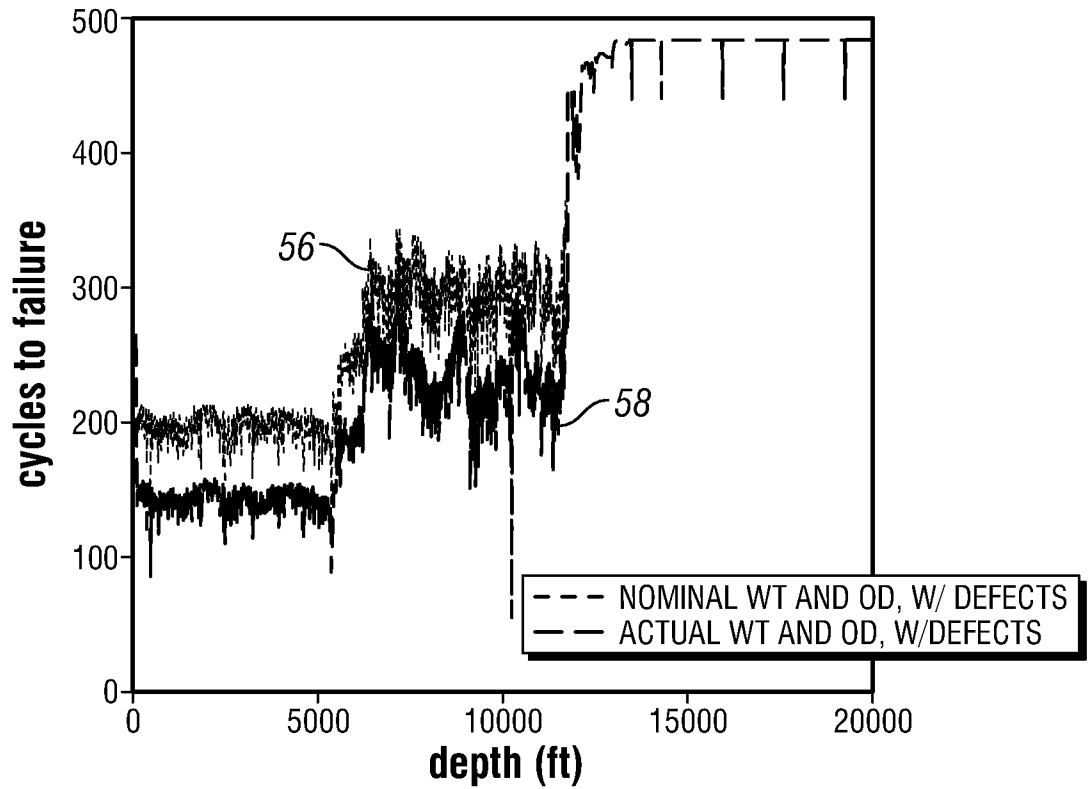

FIG. 8

5/7

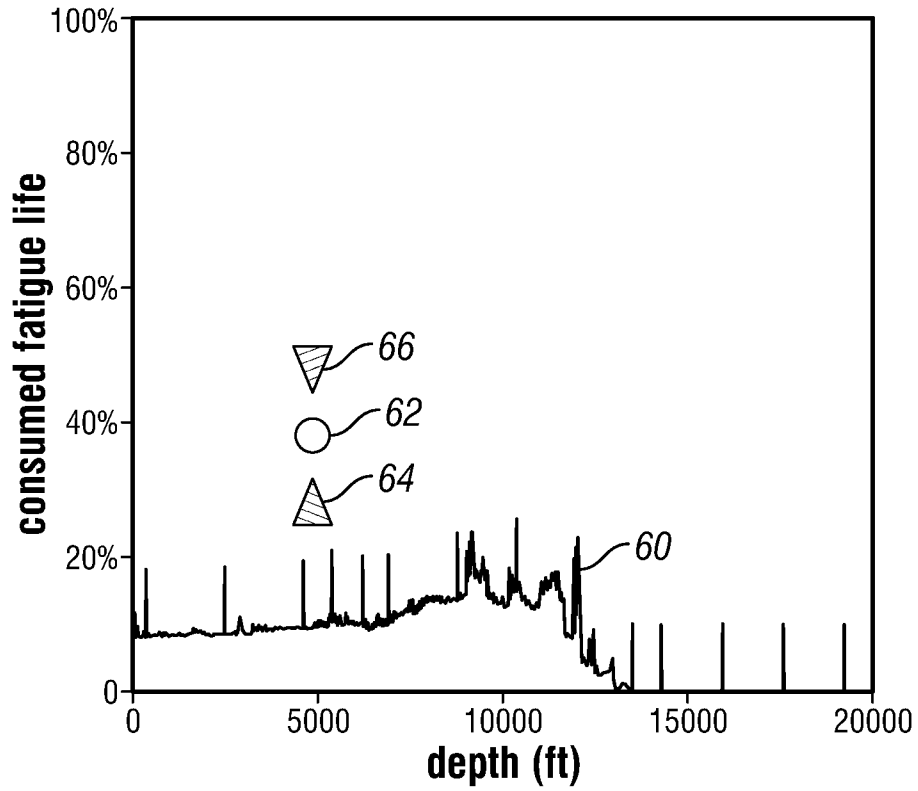

FIG. 9

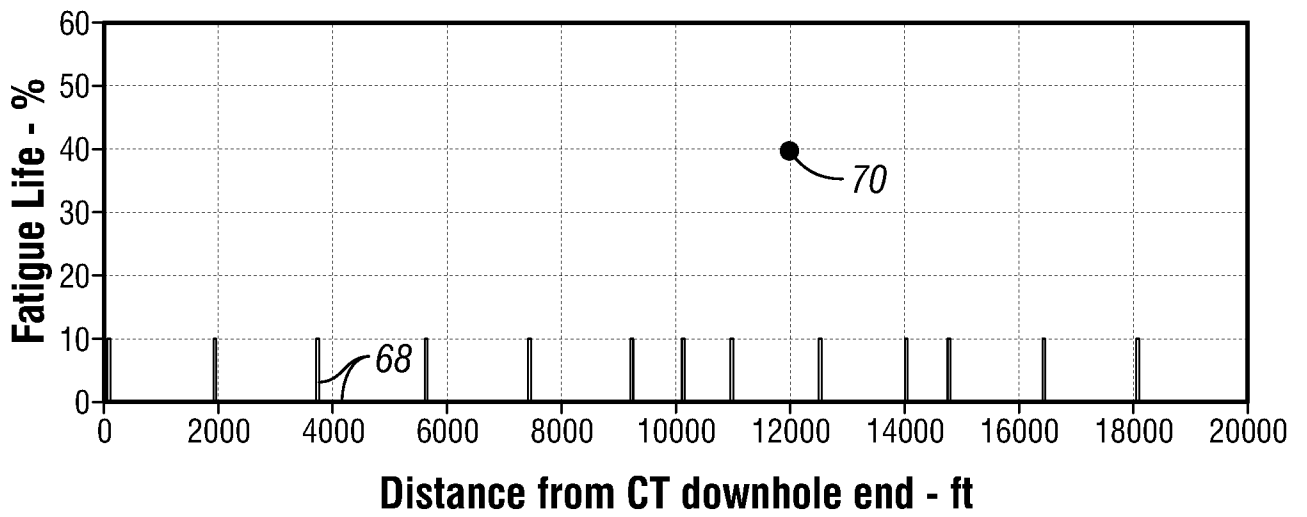

FIG. 10

6/7

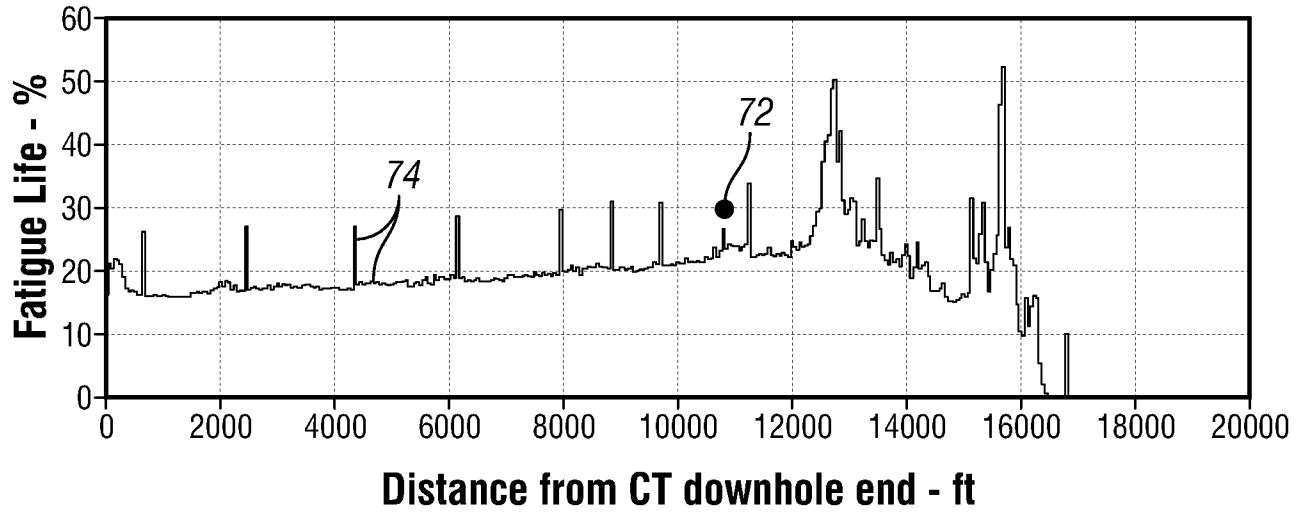

FIG. 11

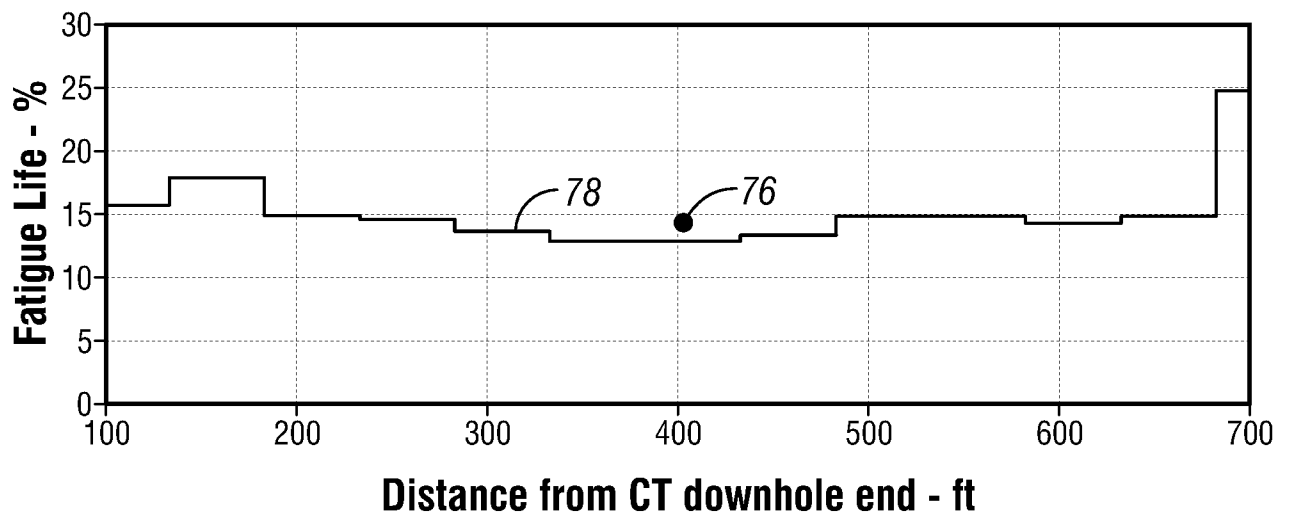

FIG. 12

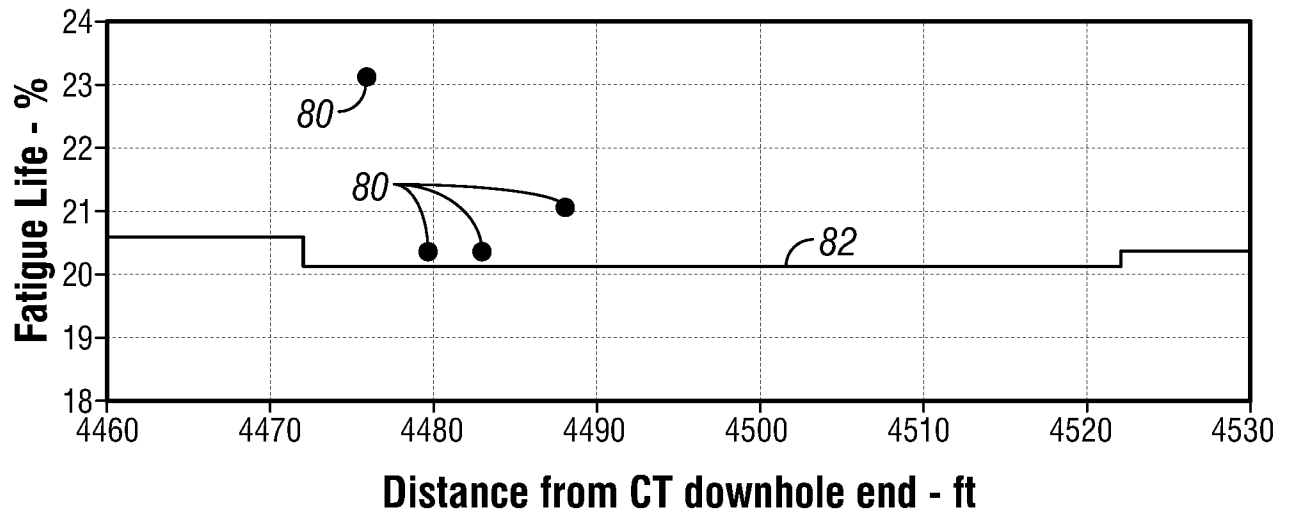

FIG. 13

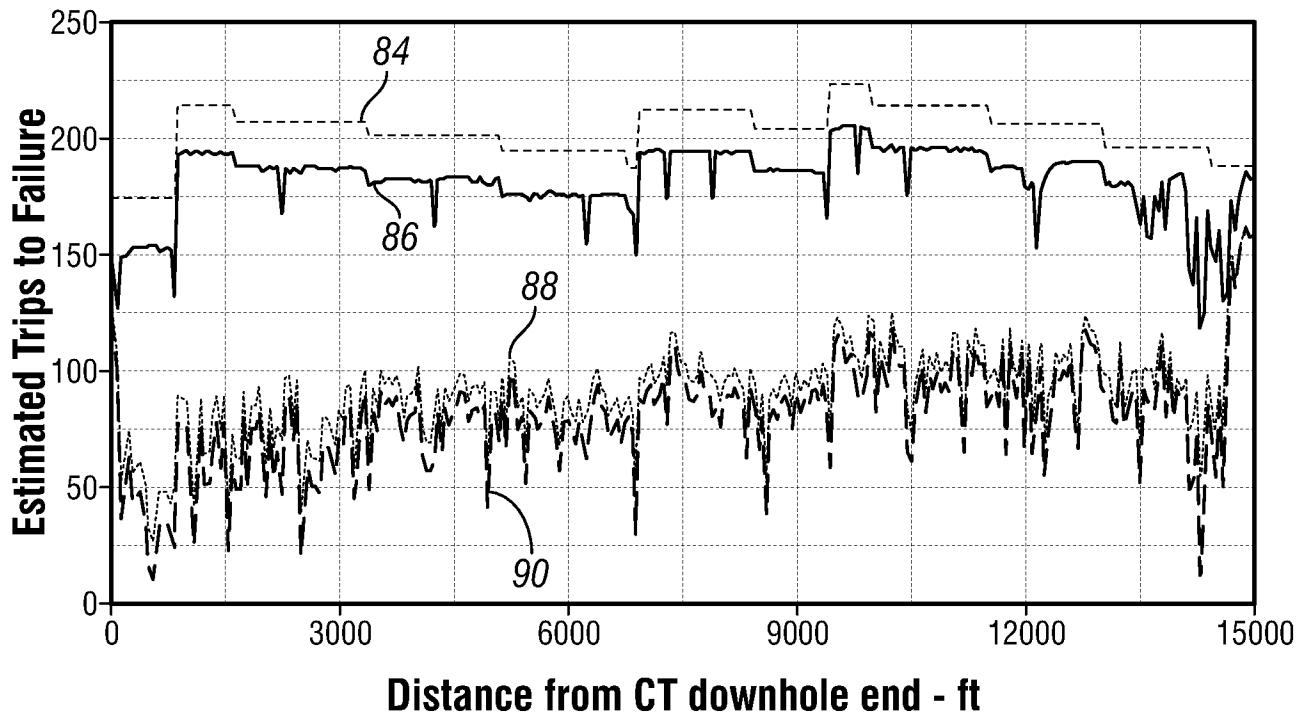

FIG. 14

A. CLASSIFICATION OF SUBJECT MATTER**G01N 23/18(2006.01)i**

According to International Patent Classification (IPC) or to both national classification and IPC

B. FIELDS SEARCHEDMinimum documentation searched (classification system followed by classification symbols)
G01N 23/18; G06F 19/00; F16I 5516; G01N 27/83; G01M 3/40; G01M 19/00; G01N 27/90Documentation searched other than minimum documentation to the extent that such documents are included in the fields searched
Korean utility models and applications for utility models
Japanese utility models and applications for utility modelsElectronic data base consulted during the international search (name of data base and, where practicable, search terms used)
eKOMPASS(KIPO internal) & keywords: estimate, fatigue, cycle, failure, defect, tubing, MFL and anomaly**C. DOCUMENTS CONSIDERED TO BE RELEVANT**

Category*	Citation of document, with indication, where appropriate, of the relevant passages	Relevant to claim No.
Y	WO 2015-051225 A1 (SCHLUMBERGER CANADA LIMITED et al.) 09 April 2015 see paragraphs [0017]-[0022], [0036], claims 1, 15 and figures 1-4.	1-7,18-20
A		8-17
Y	US 2013-0060487 A1 (PAPADIMITRIOU et al.) 07 March 2013 See abstract, claims 50, 51 and figures 1-6.	1-7,18-20
A	US 2014-0200831 A1 (SMITH et al.) 17 July 2014 See abstract, paragraphs [0011]-[0030] and claims 1-17.	1-20
A	US 6820653 B1 (SCHEMPF et al.) 23 November 2004 See abstract, claims 1-10 and figure 1.	1-20
A	US 6023986 A (SMITH et al.) 15 February 2000 See abstract, claims 1-8 and figure 1.	1-20

 Further documents are listed in the continuation of Box C. See patent family annex.

* Special categories of cited documents:

"A" document defining the general state of the art which is not considered to be of particular relevance

"E" earlier application or patent but published on or after the international filing date

"L" document which may throw doubts on priority claim(s) or which is cited to establish the publication date of another citation or other special reason (as specified)

"O" document referring to an oral disclosure, use, exhibition or other means

"P" document published prior to the international filing date but later than the priority date claimed

"T" later document published after the international filing date or priority date and not in conflict with the application but cited to understand the principle or theory underlying the invention

"X" document of particular relevance; the claimed invention cannot be considered novel or cannot be considered to involve an inventive step when the document is taken alone

"Y" document of particular relevance; the claimed invention cannot be considered to involve an inventive step when the document is combined with one or more other such documents, such combination being obvious to a person skilled in the art

"&" document member of the same patent family

Date of the actual completion of the international search

12 June 2017 (12.06.2017)

Date of mailing of the international search report

12 June 2017 (12.06.2017)

Name and mailing address of the ISA/KR

International Application Division
Korean Intellectual Property Office
189 Cheongsu-ro, Seo-gu, Daejeon, 35208, Republic of Korea

Facsimile No. +82-42-481-8578

Authorized officer

LEE, Hun Gil

Telephone No. +82-42-481-8525



INTERNATIONAL SEARCH REPORT

Information on patent family members

International application No.

PCT/US2017/022620

Patent document cited in search report	Publication date	Patent family member(s)	Publication date
WO 2015-051225 A1	09/04/2015	US 2016-0252481 A1	01/09/2016
US 2013-0060487 A1	07/03/2013	US 8831894 B2	09/09/2014
US 2014-0200831 A1	17/07/2014	EA 201391095 A1	30/12/2013
		NO 20131001 A1	01/08/2013
		US 2014-0207390 A1	24/07/2014
		WO 2012-103541 A2	02/08/2012
		WO 2012-103541 A3	01/11/2012
		WO 2012-174057 A1	20/12/2012
US 6820653 B1	23/11/2004	None	
US 6023986 A	15/02/2000	None	