

[72] Inventors **David W. Lewis;**
George L. Falkenhagen, Charlottesville,
 [21] Appl. No. **759,180**
 [22] Filed **Sept. 11, 1968**
 [45] Patented **Jan. 5, 1971**
 [73] Assignees **Leo J. Aubel**
Deerfield, Ill., a part interest

[56] **References Cited**
UNITED STATES PATENTS
 2,113,683 4/1938 DeWitt..... 220/31SRUX
 2,642,202 6/1953 Cowan 220/31(SR)
 3,251,460 5/1966 Edmonds..... 220/4X

Primary Examiner—George E. Lowrance
Attorneys—Stone, Zummer, Livingston & Aubel

[54] **COMPUTER CARD CARRYING BOX**
 1 Claim, 6 Drawing Figs.

[52] U.S. Cl..... 220/8,
 220/31SR
 [51] Int. Cl..... B65d 7/24
 [50] Field of Search..... 220/4, 4E,
 8, 31SR

ABSTRACT: A computer card box is disclosed for storing and carrying computer (IBM) cards, the card box being readily expandable and having pockets for accommodating a band which holds the cards.

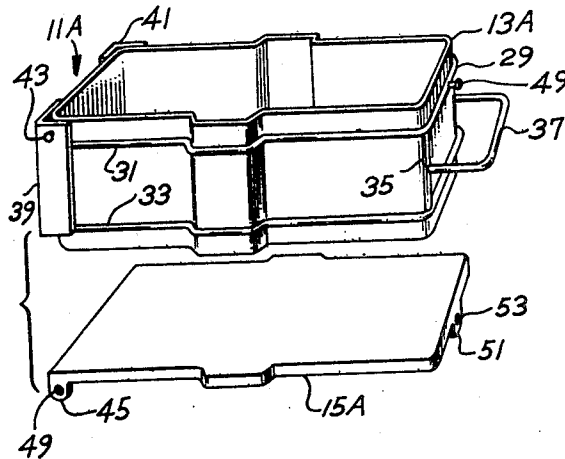

Fig. 1

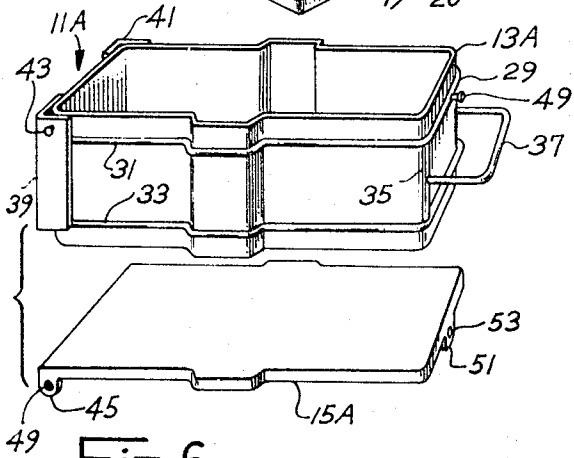
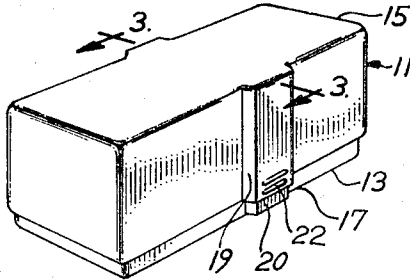

Fig. 6

Fig. 2

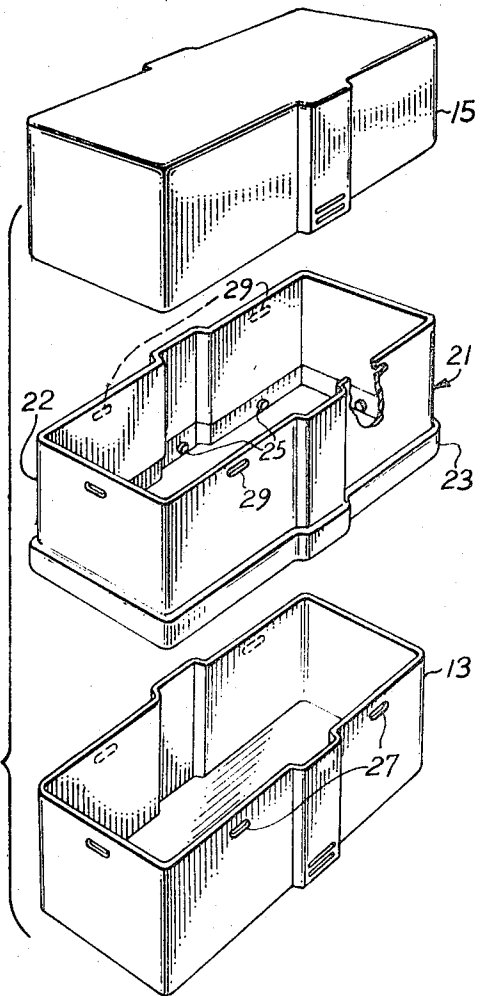

Fig. 4

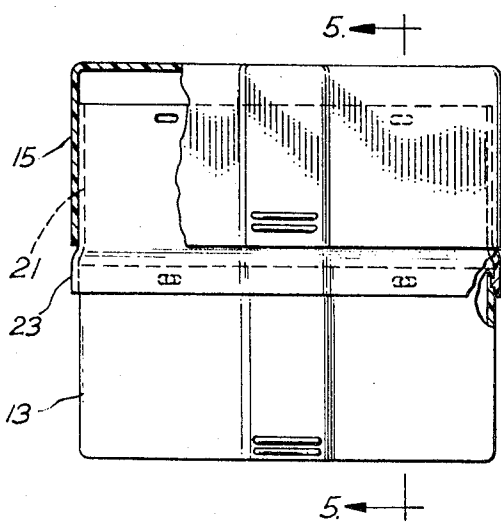

Fig. 5

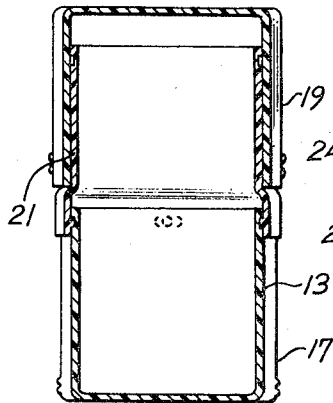
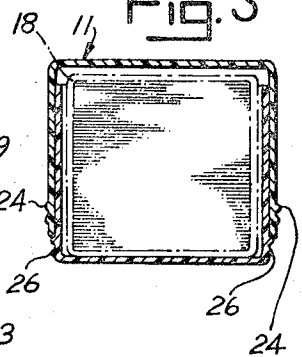

Fig. 3



INVENTORS
 DAVID W. LEWIS &
 BY GEORGE L. FALKENHAGEN
Petherbridge, O'Neill & Subel
 Attorneys

COMPUTER CARD CARRYING BOX

There is a growing demand for use of computers in various facilities, especially in technical schools. The use for computers, in turn, normally requires the use of computer (IBM) information storage cards for utilization with or by the computer. These cards are handled and carried by the computer user from one place to another.

While the prior art includes cases for transporting IBM cards; such prior art cases are relatively bulky and heavy. Accordingly, there is a present need for a means of storing and carrying computer cards conveniently, as in small groups, including means for preventing the cards from getting damaged or soiled by the elements. The box of the invention completely encapsulates a group of cards to facilitate the handling of the cards, and to protect them from the elements and from damage.

Briefly, the invention provides a computer card-carrying box which may be constructed of a plastic or other suitable material to accommodate the standard computer card and which is expandable to accommodate groups of cards of various thickness. The card-carrying box of the invention has pockets for accommodating a band, usually a rubberband, with which the cards are retained as a group.

The foregoing and other objects, features and advantages of the invention will be apparent from the following more particular description of preferred embodiments of the invention, as illustrated in the accompanying drawings.

In the drawings:

FIG. 1 shows an isometric view of the card box in accordance with the invention;

FIG. 2 is an exploded view of the box of FIG. 1 showing an expansion unit;

FIG. 3 is a cross-sectional view taken along lines 3-3 of FIG. 1 showing cards within the box and including a rubberband around the cards;

FIG. 4 is an end view of the box of FIG. 2 in a closed condition;

FIG. 5 is a cross-sectional view taken along the lines 5-5 of FIG. 4; and

FIG. 6 is an exploded view showing a modification of the box of FIG. 1 wherein the box includes a reinforcing wire structure and a handle for carrying the box.

Referring to FIG. 1, the computer card-carrying box 11 in accordance with the invention includes a rectangular bottom portion 13 having an open top, also see FIG. 2. A cover 15 similar in construction to bottom portion 13 telescopes or fits over the portion 13. The bottom portion 13 and cover 15 include outwardly extending sections 17 and 19, respectively, formed approximately midway between the ends of the box 11. The sections 17 and 19 are for purposes of accommodating a string or band such as, for example, a rubberband 18 (see also FIG. 3) which may be placed around the cards to retain the cards in a group when handled or carried in the box 11.

Horizontal ridges 24 on the outer surface of section 19 provides a convenient means by which the user's fingers can grasp the cover 15 for removing or replacing the cover. Horizontal ridges 26 on section 17 are provided to abut and limit downward (as oriented in the FIGS.) positioning of the cover 15 on bottom portion 13.

Preferably the box 11 may be made of any suitable plastic such as a transparent plastic, so that the cards within the box can be viewed without taking the cover 15 off the box. We have found boxes of metal construction to also be satisfactory.

FIG. 2 shows an exploded view of the box of FIG. 1 including an expansion unit 21 positioned in relative position between bottom portion 13 and cover 15.

The expansion unit 21 comprises a rectangular shaped shell 22 open at the top and bottom ends and similar in peripheral outline to bottom portion 13 and cover 15, as clearly shown in FIG. 2. The lower portion of the shell 22 includes an outstanding shoulder 23 formed around its periphery. Shoulder 23 is arranged to fit around and telescope onto the upper edge of the bottom portion 13, also see FIGS. 4 and 5.

The shoulder 23 includes spaced positioning pins 25 extending inwardly from its inner surface. Pins 25 are received in recesses 27 formed on the outer surface and adjacent to the upper edge of bottom portion 13. Expansion unit 21 is conveniently affixed to bottom portion 13 merely by snapping the pins 25 into recesses 27 to thereby firmly affix the expansion unit 21 on the bottom portion 13. Note that the recesses 27 do not pierce the shell 21, but are in the form of depressions in the surface of bottom portion 13.

The upper section of the expansion unit 21 is of the same size as the bottom unit 13 and is adapted to receive or permit the telescoping of the cover 15 thereon, as shown in FIG. 4.

The upper edge of expansion unit 21 includes recess 29 therein similar to recesses 27 in bottom portion 13 for receiving additional expansion units such as 21 whereby the height of the box 11 can be enlarged as desired by adding and affixing expansion units 21 to one another.

FIG. 6 shows an exploded view of a card-carrying box 11A which is a modification of the boxes shown in FIGS. 1-5. Box 11A includes a bottom portion 13A similar to bottom portion 13 of FIGS. 1-5. A wire frame 29 conforms to and is placed around the periphery of bottom portion 13A. Frame 29 comprises a pair of spaced wires 31 and 33 entirely encompassing the periphery of the box 13A. Spaced cross wires 35, only one cross wire being shown in FIG. 6, are positioned at the right-hand (as oriented in FIG. 6) corners of frame 29 to affix the two wires 31 and 35 to each other. A wire handle 37 is mounted on cross wires 35. Thus the wire frame 29 stiffens or strengthens the box 11 as well as providing means for conveniently carrying the box by a handle.

A pair of corner flanges 39 and 41 are placed on the left-hand corners of the bottom portion 13A.

The flanges 39 and 41 include respective cover attaching pins 43; only one being shown in FIG. 6. The cover 15A for bottom portion 13A includes a pair of hinging ears 45, only one being shown in FIG. 6. Each ear 45 has an aperture 47 formed thereon which can be snap fitted on its respective pin 43. Accordingly, cover 15A can be hingedly mounted on the bottom portion 13A.

A closure pin 49 is formed on wire 31 adjacent the handle 37. The cover 15A includes a closure ear 51 having an aperture 53 which receives the pin 49. Closure ear 51 and aperture 53 snaps over pin 49 to permit closure of the cover 15A on bottom portion 13A.

Note that the embodiment of FIG. 6 the wire frame 29 may be dispensed with, and the hinge pins such as 43 and the closure pin 49 can be formed directly on bottom portion 13A. This may be desirable to reduce the cost of manufacturing the box of the invention.

While the invention has been particularly shown and described with reference to preferred embodiments thereof, it will be understood by those skilled in the art that changes in form and details may be made therein without departing from the spirit and scope of the invention.

We claim:

1. A box for carrying groups of computer cards comprising: a rectangular bottom portion having a base, sides and an open top; a cover for said bottom portion, said cover being similar to said bottom portion in peripheral outline; an expansion unit comprising a rectangular shell for receiving said cards and being similar to said bottom portion in peripheral outline; an outwardly extending shoulder on the lower periphery of said expansion unit receivable on said bottom portion; said bottom portion including recesses along its upper edges thereof; positioning pins formed on said shoulder of said expansion unit and receivable in said recesses whereby said expansion unit may be snapped into position on said bottom portion; and the upper periphery of said expansion unit being telescopable into said cover.