



(51) International Patent Classification:

H04R 5/02 (2006.01) *H04S 7/00* (2006.01)
H04R 5/033 (2006.01) *H04W 4/02* (2018.01)

33880 Lempäälä (FI). **ERONEN, Antti**; Rintamäenkatu 13
A 6, 33820 Tampere (FI). **CRICRI, Francesco**; Massunkun-
ja 1 A 14, 33100 Tampere (FI).

(21) International Application Number:

PCT/FI2017/050792

(74) Agent: **NOKIA TECHNOLOGIES OY** et al.; Ari Aarnio,
IPR Department, Karakaari 7, 02610 Espoo (FI).

(22) International Filing Date:

20 November 2017 (20.11.2017)

(81) Designated States (unless otherwise indicated, for every

kind of national protection available): AE, AG, AL, AM,
AO, AT, AU, AZ, BA, BB, BG, BH, BN, BR, BW, BY, BZ,
CA, CH, CL, CN, CO, CR, CU, CZ, DE, DJ, DK, DM, DO,
DZ, EC, EE, EG, ES, FI, GB, GD, GE, GH, GM, GT, HN,
HR, HU, ID, IL, IN, IR, IS, JO, JP, KE, KG, KH, KN, KP,
KR, KW, KZ, LA, LC, LK, LR, LS, LU, LY, MA, MD, ME,
MG, MK, MN, MW, MX, MY, MZ, NA, NG, NI, NO, NZ,
OM, PA, PE, PG, PH, PL, PT, QA, RO, RS, RU, RW, SA,
SC, SD, SE, SG, SK, SL, SM, ST, SV, SY, TH, TJ, TM, TN,
TR, TT, TZ, UA, UG, US, UZ, VC, VN, ZA, ZM, ZW.

(25) Filing Language:

English

(26) Publication Language:

English

(30) Priority Data:

1620325.9 30 November 2016 (30.11.2016) GB

(71) Applicant: **NOKIA TECHNOLOGIES OY** [FI/FI];
Karaportti 3, 02610 Espoo (FI).

(72) Inventors: **LEPPÄNEN, Jussi**; Mielikinkatu 26, 33580
Tampere (FI). **LEHTINIEMI, Arto**; Lomarantatie 17,

(54) Title: DISTRIBUTED AUDIO CAPTURE AND MIXING

Figure 1

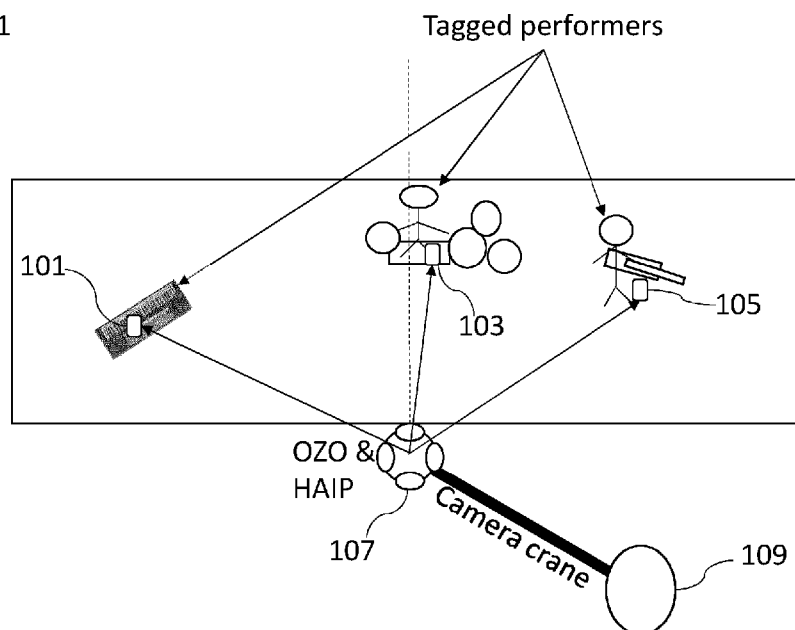

(57) Abstract: An apparatus for controlling a controllable position/orientation of at least one audio source within an audio scene, the audio scene comprising: the at least one audio source; a capture device comprising a microphone array for capturing audio signals of the audio scene, the capture device having a capture orientation wherein the microphone array is positioned relative to the capture orientation, the apparatus comprising a processor configured to: receive a physical position/orientation of the at least one audio source relative to the capture device capture orientation; receive an earlier physical position/orientation of the at least one audio source relative to the capture device capture orientation; receive at least one control parameter; and control a controllable position/orientation of the at least one audio source, the controllable position being between the physical position/orientation of the at least one audio source relative to the capture device capture orientation and the earlier physical position/orientation of the at least one audio source relative to the capture device capture orientation and based on the control parameter.



(84) Designated States (*unless otherwise indicated, for every kind of regional protection available*): ARIPO (BW, GH, GM, KE, LR, LS, MW, MZ, NA, RW, SD, SL, ST, SZ, TZ, UG, ZM, ZW), Eurasian (AM, AZ, BY, KG, KZ, RU, TJ, TM), European (AL, AT, BE, BG, CH, CY, CZ, DE, DK, EE, ES, FI, FR, GB, GR, HR, HU, IE, IS, IT, LT, LU, LV, MC, MK, MT, NL, NO, PL, PT, RO, RS, SE, SI, SK, SM, TR), OAPI (BF, BJ, CF, CG, CI, CM, GA, GN, GQ, GW, KM, ML, MR, NE, SN, TD, TG).

Published:

— *with international search report (Art. 21(3))*

DISTRIBUTED AUDIO CAPTURE AND MIXING

Field

The present application relates to apparatus and methods for distributed audio capture and mixing. The invention further relates to, but is not limited to, apparatus and methods for distributed audio capture and mixing for spatial processing of audio signals to enable spatial reproduction of audio signals.

Background

Capture of audio signals from multiple sources and mixing of audio signals when these sources are moving in the spatial field requires significant effort. For example the capture and mixing of an audio signal source such as a speaker or artist within an audio environment such as a theatre or lecture hall to be presented to a listener and produce an effective audio atmosphere requires significant investment in equipment and training.

A commonly implemented system is where one or more close microphones, for example a Lavalier microphone worn by the user or an audio channel associated with an instrument is mixed with a suitable spatial (or environmental or audio field) audio signal such that the produced sound comes from an intended direction.

However as will be shown hereafter the positioning of the close microphone and other audio sources relative to the capture device may produce a poor quality output where the audio sources are not significantly distributed.

Thus, there is a need to develop solutions which enhance the spatial audio mixing and sound track creation process.

Summary

There is provided according to a first aspect an apparatus for controlling a controllable position/orientation of at least one audio source within an audio scene, the audio scene comprising: the at least one audio source; a capture device comprising a microphone array for capturing audio signals of the audio scene, the capture device having a capture orientation wherein the microphone array is positioned relative to the capture orientation, the apparatus comprising a processor configured to: receive a physical position/orientation of the at least one audio source relative to the capture

device capture orientation; receive an earlier physical position/orientation of the at least one audio source relative to the capture device capture orientation; receive at least one control parameter; and control a controllable position/orientation of the at least one audio source, the controllable position being between the physical position/orientation of the at least one audio source relative to the capture device capture orientation and the earlier physical position/orientation of the at least one audio source relative to the capture device capture orientation and based on the control parameter.

The capture device may further comprise at least one camera for capturing images of the audio scene, wherein the at least one camera may be positioned relative to the capture orientation.

During a capture session the controllable position/orientation for the at least one audio source may be defined for one of the at least one audio source between the earlier physical position/orientation which may be captured on a first image of the at least one camera and the physical position/orientation which may be captured on a second image of the at least one camera.

The processor configured to control the controllable position/orientation of the at least one audio source may be configured to control the controllable position/orientation of the at least one audio source relative to the capture device capture orientation such that the controllable position/orientation may be the earlier physical position/orientation of the at least one audio source relative to the capture device capture orientation, such that a visually observed position/orientation of the at least one audio source differs from an audio experienced position/orientation of the at least one audio source.

The processor may be configured to pass the controllable position/orientation of the at least one audio source to a renderer to control a mixing or rendering of an audio signal associated with the at least one audio source based on the controllable position/orientation.

The processor configured to receive at least one control parameter may be configured to receive a weighting parameter, and the processor configured to control the controllable position/orientation may be further configured to: determine the controllable orientation based on one of the physical orientation of the at least one audio source relative to the capture device capture orientation and the earlier physical

orientation of the at least one audio source relative to the capture device capture orientation which is combined with the product of the weighting parameter applied to an orientation difference between the the physical orientation of the at least one audio source relative to the capture device capture orientation and the earlier physical position/orientation of the at least one audio source relative to the capture device capture orientation; and determine the controllable position as the intersection between a line described by the physical position of the at least one audio source relative to the capture device capture orientation and the earlier physical position of the at least one audio source relative to the capture device reference orientation and a line from the capture device at the controllable orientation.

The processor configured to receive at least one control parameter may be configured to receive a weighting parameter, and the processor configured to control the controllable position/orientation may be further configured to: determine the controllable orientation based on one of the physical orientation of the at least one audio source relative to the capture device capture orientation and the earlier physical orientation of the at least one audio source relative to the capture device capture orientation combined with the product of the weighting parameter applied to an orientation difference between the the physical orientation of the at least one audio source relative to the capture device capture orientation and the earlier physical position/orientation of the at least one audio source relative to the capture device capture orientation, and determine the controllable position based on an arc with an origin at the capture device and defined by the physical position of the at least one audio source relative to the capture device capture orientation and the earlier physical position of the at least one audio source relative to the capture device capture orientation to the capture device capture orientation and a line from the capture device at the controllable orientation.

The processor configured to receive the at least one control parameter may be configured to receive a weighting parameter, and wherein the processor configured to control the controllable position/orientation may be further configured to combine the product of unity minus the weighting parameter to the physical position of the at least one audio source relative to the capture device capture orientation and the product of the weighting function to the earlier physical position of the at least one audio source relative to the capture device capture orientation.

The processor configured to control the controllable position/orientation of the at least one audio source may be further configured to control a width of the controllable position/orientation, the width of the controllable position/orientation may be based on the distance from the physical position/orientation of at least one audio source relative to the capture device capture orientation.

The processor configured to control the width of the controllable position/orientation may be configured to set the width of the controllable position/orientation as one half a normalised distance from the physical position/orientation of the at least one audio source relative to the capture device capture orientation.

According to a second aspect there is provided a method for controlling a controllable position/orientation of at least one audio source within an audio scene, the audio scene comprising: the at least one audio source; a capture device comprising a microphone array for capturing audio signals of the audio scene, the capture device having a capture orientation wherein the microphone array is positioned relative to the capture orientation, the method comprising: receiving a physical position/orientation of the at least one audio source relative to the capture device capture orientation; receiving an earlier physical position/orientation of the at least one audio source relative to the capture device capture orientation; receiving at least one control parameter; and controlling a controllable position/orientation of the at least one audio source, the controllable position being between the physical position/orientation of the at least one audio source relative to the capture device capture orientation and the earlier physical position/orientation of the at least one audio source relative to the capture device capture orientation and based on the control parameter.

The capture device may further comprise at least one camera for capturing images of the audio scene, wherein the at least one camera may be positioned relative to the capture orientation.

During a capture session the controllable position/orientation for the at least one audio source may be defined for one of the at least one audio source between the earlier physical position/orientation which may be captured on a first image of the at least one camera and the physical position/orientation which may be captured on a second image of the at least one camera.

Controlling the controllable position/orientation of the at least one audio source may comprise controlling the controllable position/orientation of the at least one audio source relative to the capture device capture orientation such that the controllable position/orientation is the earlier physical position/orientation of the at least one audio source relative to the capture device capture orientation, such that a visually observed position/orientation of the at least one audio source differs from an audio experienced position/orientation of the at least one audio source.

The method may further comprise passing the controllable position/orientation of the at least one audio source to a renderer to control a mixing or rendering of an audio signal associated with the at least one audio source based on the controllable position/orientation.

Receiving at least one control parameter may comprise receiving a weighting parameter, and controlling the controllable position/orientation may further comprise: determining the controllable orientation based on one of the physical orientation of the at least one audio source relative to the capture device capture orientation and the earlier physical orientation of the at least one audio source relative to the capture device capture orientation which is combined with the product of the weighting parameter applied to an orientation difference between the the physical orientation of the at least one audio source relative to the capture device capture orientation and the earlier physical position/orientation of the at least one audio source relative to the capture device capture orientation, and determining the controllable position as the intersection between a line described by the physical position of the at least one audio source relative to the capture device capture orientation and the earlier physical position of the at least one audio source relative to the capture device reference orientation and a line from the capture device at the controllable orientation.

Receiving at least one control parameter may comprise receiving a weighting parameter, and controlling the controllable position/orientation may further comprise: determining the controllable orientation based on one of the physical orientation of the at least one audio source relative to the capture device capture orientation and the earlier physical orientation of the at least one audio source relative to the capture device capture orientation combined with the product of the weighting parameter applied to an orientation difference between the the physical orientation of the at least one audio source relative to the capture device capture orientation and the earlier

physical position/orientation of the at least one audio source relative to the capture device capture orientation, and determining the controllable position based on an arc with an origin at the capture device and defined by the physical position of the at least one audio source relative to the capture device capture orientation and the earlier
5 physical position of the at least one audio source relative to the capture device capture orientation to the capture device capture orientation and a line from the capture device at the controllable orientation.

Receiving the at least one control parameter may comprise receiving a weighting parameter, and wherein controlling the controllable position/orientation may
10 further comprise combining the product of unity minus the weighting parameter to the physical position of the at least one audio source relative to the capture device capture orientation and the product of the weighting function to the earlier physical position of the at least one audio source relative to the capture device capture orientation.

Controlling the controllable position/orientation of the at least one audio source
15 may further comprise controlling a width of the controllable position/orientation, the width of the controllable position/orientation being based on the distance from the physical position/orientation of at least one audio source relative to the capture device capture orientation.

Controlling the width of the controllable position/orientation may comprise
20 setting the width of the controllable position/orientation as one half the normalised distance from the physical position/orientation of the at least one audio source relative to the capture device capture orientation.

A computer program product stored on a medium may cause an apparatus to perform the method as described herein.

25 An electronic device may comprise apparatus as described herein.

A chipset may comprise apparatus as described herein.

Embodiments of the present application aim to address problems associated with the state of the art.

30 Summary of the Figures

For a better understanding of the present application, reference will now be made by way of example to the accompanying drawings in which:

Figure 1 shows schematically an example capture and mixing arrangement where the close microphones and the microphone array are in a first position arrangement producing a wide separation of sound sources;

5 Figure 2 shows schematically a further example capture and mixing arrangement where the close microphones and the microphone array are in a second position arrangement;

Figure 3 shows schematically the narrow separation of sound sources produced by the close microphones and the microphone array in the second position arrangement;

10 Figure 4 shows schematically the further example capture and mixing arrangement where the close microphones and the microphone array are in a second position arrangement, but the controllable position/orientations are a mapped first position arrangement;

15 Figure 5 shows schematically the further example capture and mixing arrangement where the close microphones and the microphone array are in a second position arrangement, but the controllable position/orientations are controlled to be between the second position and mapped first position arrangement;

Figure 6 shows schematically a first control parameter application to produce the controllable position/orientations according to some embodiments;

20 Figure 7 shows schematically a second control parameter application to produce the controllable position/orientations according to some embodiments;

Figures 8a and 8b show schematically a further control parameter application to widen the spatial extent of the controllable position/orientations according to some embodiments;

25 Figure 9 shows an example mixing apparatus for controlling the position of the controllable position/orientations according to some embodiments;

Figure 10 shows an example flow diagram for controlling the position of the controllable position/orientations according to some embodiments; and

30 Figure 11 shows schematically an example device suitable for implementing the capture and/or render apparatus shown in Figure 9.

Embodiments of the Application

The following describes in further detail suitable apparatus and possible mechanisms for the provision of effective capture of audio signals from multiple sources and mixing of those audio signals when these sources are moving in the spatial field. In the following examples, audio signals and audio capture signals are described. However it would be appreciated that in some embodiments the apparatus may be part of any suitable electronic device or apparatus configured to capture an audio signal or receive the audio signals and other information signals.

A conventional approach to the capturing and mixing of audio sources with respect to an audio background or environment audio field signal would be for a professional producer to utilize a close microphone (a Lavalier microphone worn by the user, or a microphone attached to an instrument or some other microphone) to capture audio signals close to the audio source, and further utilize a 'background' microphone to capture a environmental audio signal. These signals or audio tracks may then be manually mixed to produce an output audio signal such that the produced sound features the audio source coming from an intended (though not necessarily the original) direction.

The concept as described herein may be considered to be enhancement to conventional Spatial Audio Capture (SPAC) technology. Spatial audio capture technology can process audio signals captured via a microphone array into a spatial audio format. In other words generating an audio signal format with a spatial perception capacity. The concept may thus be embodied in a form where audio signals may be captured such that, when rendered to a user, the user can experience the sound field as if they were present at the location of the capture device. Spatial audio capture can be implemented for microphone arrays found in mobile devices. In addition, audio processing derived from the spatial audio capture may be used employed within a presence-capturing device such as the Nokia OZO (OZO) devices.

In the examples described herein the audio signal is rendered into a suitable binaural form, where the spatial sensation may be created using rendering such as by head-related-transfer-function (HRTF) filtering a suitable audio signal.

The concept as described with respect to the embodiments herein makes it possible to capture and remix a close and environment audio signal more effectively

and produce a better quality output where the sound or audio sources are more widely distributed.

The concept may for example be embodied as a capture system configured to capture both a close (speaker, instrument or other source) audio signal and a
5 microphone array or spatial (audio field) audio signal. The capture system may furthermore be configured to determine a location of the close audio signal source relative to the spatial capture components and further determine the audio signal delay required to synchronize the close audio signal to the spatial audio signal. This information may then be stored or passed to a suitable rendering system which having
10 received audio signals associated with the microphones and microphone array and the spatial metadata such as positional information may use this information to generate a suitable mixing and rendering of the audio signal to a user.

Furthermore in some embodiments the render system enables the user to input a suitable input to control the mixing, for example control the positioning of the close
15 microphone mixing positions.

The concept furthermore is embodied by the ability to track locations of the close microphones generating the close audio signals using high-accuracy indoor positioning or another suitable technique. The position or location data (azimuth, elevation, distance) can then be associated with the spatial audio signal captured by
20 the microphones. The close audio signals captured by the close microphones may in some embodiments be furthermore processed, for example time-aligned with the microphone array audio signal, and made available for rendering. For reproduction with static loudspeaker setups such as 5.1., a static downmix can be done using amplitude panning techniques. For reproduction using binaural techniques, the time-
25 aligned close microphone audio signals can be stored or communicated together with time-varying spatial position data and the microphone array audio signals or audio track. For example, the audio signals could be encoded, stored, and transmitted in a Moving Picture Experts Group (MPEG) MPEG-H 3D audio format, specified as ISO/IEC 23008-3 (MPEG-H Part 3), where ISO stands for International Organization
30 for Standardization and IEC stands for International Electrotechnical Commission.

It is believed that the main benefits of the invention include flexible capturing of spatial audio and separation of close microphone audio signals, which enables an enhanced rendering of the audio signals for the user or listener. An example includes

increasing speech intelligibility in noisy capture situations, in reverberant environments, or in capture situations with multiple direct and ambient sources.

Although capture and render systems may be separate, it is understood that they may be implemented with the same apparatus or may be distributed over a series
5 of physically separate but communication capable apparatus. For example, a presence-capturing device such as the OZO device could be equipped with an additional interface for receiving location data and close microphone audio signals, and could be configured to perform the capture part. The output of a capture part of
10 the system may be the microphone audio signals (e.g. as a 5.1 channel downmix), the close microphone audio signals (which may furthermore be time-delay compensated to match the time of the microphone array audio signals), and the position information of the close microphones (such as a time-varying azimuth, elevation, distance with regard to the microphone array).

In some embodiments the raw microphone array audio signals captured by the
15 microphone array may be transmitted to the renderer (instead of spatial audio processed into 5.1), and the renderer performs spatial processing such as described herein.

The renderer as described herein may be an audio playback device (for example a set of headphones), user input (for example motion tracker), and software
20 capable of mixing and audio rendering. In some embodiments the user input and audio rendering parts may be implemented within a computing device with display capacity such as a mobile phone, tablet computer, virtual reality headset, augmented reality headset etc.

Furthermore it is understood that at least some elements of the following mixing
25 and rendering may be implemented within a distributed computing system such as known as the 'cloud'.

With respect to Figure 1 is shown a first example capture and mixing arrangement where the close microphones and the microphone array are in a first position arrangement producing a wide separation of sound sources. In this and the
30 following examples a band performance is being recorded. However this is an example implementation only and it is understood that the apparatus may be used in any suitable recording scenario.

Figure 1 shows the performers' 101, 103, 105 (and/or the instruments that are being played) positions being tracked (by using position tags) and equipped with microphones. For example the capture apparatus 101 comprises a Lavalier microphone 111. The close microphones may be any microphone external or separate
5 to microphone array configured to capture the spatial audio signal. Thus the concept is applicable to any external/additional microphones be they Lavalier microphones, hand held microphones, mounted mics, or whatever. The external microphones can be worn/carried by persons or mounted as close-up microphones for instruments or a microphone in some relevant location which the designer wishes to capture accurately.
10 The close microphone may in some embodiments be a microphone array. A Lavalier microphone typically comprises a small microphone worn around the ear or otherwise close to the mouth. For other sound sources, such as musical instruments, the audio signal may be provided either by a Lavalier microphone or by an internal microphone system of the instrument (e.g., pick-up microphones in the case of an electric guitar)
15 or an internal audio output (e.g., a electric keyboard output). In some embodiments the close microphone may be configured to output the captured audio signals to a mixer. The close microphone may be connected to a transmitter unit (not shown), which wirelessly transmits the audio signal to a receiver unit (not shown).

Furthermore in some embodiments the close microphone comprises or is
20 associated with a microphone position tag. The microphone position tag may be configured to transmit a radio signal such that an associated receiver may determine information identifying the position or location of the close microphone. It is important to note that microphones worn by people can be freely moved in the acoustic space and the system supporting location sensing of wearable microphone has to support
25 continuous sensing of user or microphone location. The close microphone position tag may be configured to output this signal to a position tracker. Although the following examples show the use of the HAIP (high accuracy indoor positioning) radio frequency signal to determine the location of the close microphones it is understood that any suitable position estimation system may be used (for example satellite-based position
30 estimation systems, inertial position estimation, beacon based position estimation etc.).

Furthermore the system is shown comprising a microphone array (shown by the Nokia OZO device) 107. In some embodiments the microphone array may

comprise a position estimation system such as a high accuracy in-door position (HAIP) receiver configured to determine the position of the close microphones relative to the 'reference position and orientation' of the microphone array. In some embodiments the estimation of the position of the close microphones relative to the microphone array is performed within a device separate from the microphone array. In such embodiments the microphone array may itself comprise a position tag or similar to enable the further device to estimate and/or determine the position of the microphone array and the close microphones and thus determine the relative position and orientation of the close microphones to the microphone array. The microphone array may be configured to output the tracked position information to a mixer (not shown in Figure 1).

The microphone array 107 is an example of a spatial audio capture (SPAC) device or an 'audio field' capture apparatus and may in some embodiments be a directional or omnidirectional microphone array. The microphone array may be configured to output the captured audio signals or a processed form (for example a 5.1 downmix of the audio signals) to a mixer (not shown in Figure 1).

In some embodiments the microphone array is implemented within a mobile device.

The microphone array is thus configured to capture spatial audio, which, when rendered to a listener, enables the listener to experience the sound field as if they were present in the location of the microphone array. The close microphones in such embodiments are configured to capture high quality close-up audio signals (for example from a key person's voice, or a musical instrument). When mixed to the spatial audio field, the attributes of the key source such as gain, timbre and spatial position may be adjusted in order to provide the listener with a much more realistic immersive experience. In addition, it is possible to produce more point-like auditory objects, thus increasing the engagement and intelligibility.

In this example the microphone array 107 is located on a camera crane which may pivot to change the location and orientation of the microphone array 107.

In the example shown in Figure 1 the keyboard 101 (and the associated close microphone) is shown located to the left of the scene from the perspective of the reference position, the violin 105 (and the associated close microphone) is shown located to the right of the scene from the perspective of the reference position, and the

drums 103 (and the associated close microphone) located to the front or centre of the scene from the perspective of the reference position.

In this example the audio signals from the close microphones may be rendered to the viewer/listener from the direction of their position. The positions of the microphone array and the close microphones as in Figure 1 may be carefully chosen so that the resulting sound scene is pleasing to the listener. The mix provided to the viewer/listener may sound 'good' because the various sources from the close microphone audio signals are 'nicely' separated and balanced (some on the left, some on the right).

With respect to Figure 2, the system shown in Figure 1 may change. For example between the example shown in Figure 1 and Figure 2 the microphone array may change position, by pivoting on the camera crane to produce a camera sweep and rotating to produce a camera turn. The microphone array 207 at its new position and orientation thus experiences the audio scene in a different way than the microphone array 107 at its earlier position and orientation. Furthermore the close microphone, such as the violin may move from the earlier position 105 to a new position 205.

This may lead to a problematic mix being generated by the mixer. This is because all of the close microphone audio signals are now 'coming' from the same direction with respect to the microphone array. This can be shown in Figure 3 where the separation angle 301 between all of the close microphone positions is significantly narrower than the separation angle between the close microphone positions shown in Figure 1. This is not optimal from the audio listening experience point of view as all of the audio would in the rendered mix appear to come from directly in front of the viewer/listener.

From a listener point of view the positions of the close microphones relative to the microphone array associated with the previous wide spaced close microphone arrangement would be preferable. However this approach is problematic. For example Figure 4 shows an example where the close microphones are located 'physically' in the second narrow spacing arrangement with the microphone array 207 and the close microphones 101, 103 and 205 as shown in Figures 2 and 3. Figure 4 also shows relative to the microphone array 207 a mapped close microphone location 101', 103' and 105' which represent the position of the keyboard close microphone 101, drum

close microphone 103 and violin close microphone 105 relative to the microphone array 107 in the first position when mapped to the second position arrangement.

Although this mapped position arrangement would produce a 'better' quality wider separation mix the use of these positions may produce confusion in the viewer/listener. For example the relative positions of the violin 205 and the drum 103 seen by the viewer/listener where the violin is seen to be to the left of the drums according to the camera associated with the microphone array would not be the same as the relative positions of the mapped violin 105' and mapped drums 103' where the violin is heard as being to the right of the drums.

It would be therefore beneficial to be able to somehow control the audio source positions so that a better listening experience is achieved.

The concept which is shown in embodiments such as Figure 5 is to enable the control (either by a user to provide a manual input, or a processor to implement an automatic or semi-automatic control) of the controllable (or mix or processing) position/orientations of the close microphones relative to the microphone array between an actual position arrangement and an 'optimal' or determined good position arrangement.

Thus for example Figure 5 shows the microphone array 207 and a controllable position/orientation for each of the close microphones which is a controlled position between the mapped position and the tracked position of the close microphones. Thus for example there is a keyboard controllable position/orientation 501 which is located on the line connecting the mapped keyboard position 101' and the actual keyboard position 101. Furthermore there is shown the drum controllable position/orientation 503 which is located on the line connecting the mapped drum position 103' and the actual drum position 103. Also there is shown a violin controllable position/orientation 505 which is located on the line connecting the mapped violin position 105' and the actual violin position 105.

In other words Figure 5 shows that the user (or processor) may be configured to control the sound scene such that the close microphone or sound source positions may be moved between their 'actual' or correct position (based on the HAIP or other positioning) and their somehow determined 'optimal' positions (based on listening experience). That is, the user (or processor) is given control to adjust the sound scene between the 'correct' positions and nice sounding positions.

With respect to Figures 6 to 8 the effect of the control is implemented in embodiments are shown. For each close microphone/sound source the Figures show the effect of the control for a single close microphone. As described with respect to Figure 5 the control implemented affects the controllable position/orientation for the close microphone where we consider three positions:

Firstly the close microphone actual, physical or correct position shown in the Figures by the location (x_i, y_i) , where i is the close microphone index.

A position determined to provide optimal listening experience shown in the Figures by the location (\hat{x}_i, \hat{y}_i) .

A position between these positions that is controllable by the user $(\tilde{x}_i, \tilde{y}_i)$. Note that these positions are with respect to the microphone array (which in this example is the OZO camera / HAIP positioning system).

Figure 6 for example shows an embodiment where the user (or processor) may control the controllable position/orientation $(\tilde{x}_i, \tilde{y}_i)$ 613 of the close microphone/sound source between the positions (x_i, y_i) 611 and (\hat{x}_i, \hat{y}_i) 615. As shown in Figure 6 there are three angles α , $\hat{\alpha}$ and $\tilde{\alpha}$. These angles are the angles between the microphone array (OZO device) front direction and the positions described above.

In some embodiments the user is provided a user interface control element in the form of a knob or slider, for example, to adjust a parameter w which adjusts the angle of the controllable position/orientation for the close microphone/sound source. In some embodiments the control adjustment based on the value of w is provided by:

$$\tilde{\alpha}_i = \alpha_i - w(\alpha_i - \hat{\alpha}_i), w \in [0,1], i = 1..N$$

The controllable position/orientation point $(\tilde{x}_i, \tilde{y}_i)$ 613 is then determined to be the intersection between the line described by the two points (x_i, y_i) 611 and (\hat{x}_i, \hat{y}_i) 615 and the line crossing the origin 617 at an angle $\tilde{\alpha}$. In some embodiments where the distance between the controllable position/orientation and the microphone array is required and furthermore may be obtained from the new position of the close microphone relative to the microphone array then the mix position point may be modified to be located at the distance from the microphone array along the vector defined between the origin 617 and the angle $\tilde{\alpha}$.

Figure 7 shows a further example embodiment. In the example shown in Figure 7 an alternative way to control the position of the sound source is shown. In this example a user is provided a user interface control element in the form of a knob or slider, for example, to adjust a parameter q used to control the position between the two points (x_i, y_i) 711 and (\hat{x}_i, \hat{y}_i) 715. In such embodiments the user (or processor) parameter q is configured to control the position of the close microphone based on:

$$\begin{aligned}\tilde{x}_i &= (1-q)x_i + q\hat{x}_i, q \in [0,1], i = 1..N \\ \tilde{y}_i &= (1-q)y_i + q\hat{y}_i, q \in [0,1], i = 1..N\end{aligned}$$

In some embodiments as the user (or processor) may move the close microphone/sound source position away from its correct position, it is beneficial to add some spatial extent widening to the close microphone/sound source. This widening is configured to 'soften' the effect of any mismatch in audio based (or mix) position and the video based position of the close microphone.

The control of close microphone/sound source spatial extent widening is shown in Figure 8. In Figure 8, it is shown that the 'width' of the close microphone/sound source is determined to be proportional to the distance of the controllable position/orientation point $(\tilde{x}_i, \tilde{y}_i)$ from the correct or physical position point (x_i, y_i) .

In some embodiments the 'width' of the controllable position/orientation may be set to be equal to 0.5 times the distance from the correct or physical position point.

Thus for example as shown in Figure 8a where the determined or controlled controllable position/orientation point $(\tilde{x}_i, \tilde{y}_i)$ 813 is close to the correct point (x_i, y_i) 811 and thus away from the 'optimal' point (\hat{x}_i, \hat{y}_i) 815. The spatial widening effect applied in this example results in a widening radius from the origin (microphone array 801) which is narrow and is shown in Figure 8a as a single point centred at the controllable position/orientation point.

Whereas as shown in Figure 8b the determined or controlled controllable position/orientation point $(\tilde{x}_i, \tilde{y}_i)$ 863 is away from the correct point (x_i, y_i) 861 and thus close to the 'optimal' point (\hat{x}_i, \hat{y}_i) 865. The spatial widening effect 871 applied in this example results in a widening radius from the origin (microphone array 851) which is wide and shown in Figure 8b as a distribution along the line between the correct

point (x_i, y_i) 861 and the 'optimal' point (\hat{x}_i, \hat{y}_i) 865 centred at the controllable position/orientation point.

It is noted that the examples and method described herein do not change the audio rendering functionality but may be implemented as a preprocessing module for close microphone/sound object position data. This is shown for example in Figure 9. Figure 9 shows an example implementation wherein the close microphone and tag 901 transmit HAIP signals which are received by the microphone array and tag receiver 903 in order to determine the actual position of the close microphone 901 relative to the microphone array 903. The actual position may be passed to a close microphone/sound source position data updater/position determiner 905. Having received the close microphone 901 position data (the actual position the position determiner and compares these to the adjusted ideal positions.

This comparison may in some embodiments may be used to generate a suitable user interface element which is displayed to the user and enables the user to input a suitable user input 909 which in turn defines a position parameter value (such as the parameters q or w). In some embodiments a processor may derive parameter values based on the comparison between the actual position and ideal position and determine a parameter value for a controllable position/orientation according to the equations above. The updated controllable position/orientation (for the close microphone/object) data may then be provided for mixing/audio rendering to the renderer 907, which is configured to render the audio objects in the updated positions. In other words the close microphone microphone/sound source position data is updated before it is input to the audio renderer.

The renderer 907 in some embodiments may be configured to use vector-base amplitude panning techniques when loudspeaker domain output is desired (e.g. 5.1 channel output) or use head-related transfer-function filtering if binaural output for headphone listening is desired.

With respect to Figure 10 an example flow diagram of the operation of the system as shown in Figure 9 is shown in further detail.

In some embodiments the position tracker, which may be implemented within the microphone array as part of a HAIP system or other suitable system, is configured to determine the actual positions of the close microphones/sound sources relative to the microphone array.

The operation of determining the microphone positions is shown in Figure 10 by step 1001.

The position determiner may receive the close microphone position data (the actual positions) and furthermore determine ideal or optimised positions. These ideal or optimised positions may expert user determined, by a historical liked positioning, or determined using any other suitable 'optimisation' of the positions. For example in some embodiments the selected positions may be selected by the person responsible for the mixing of the sources. In such embodiments the person responsible for the mixing defines the positions by selecting the positions for each source separately. In some embodiments the person responsible for the mixing defines the positions guiding the performers and camera to a 'default position' and setting this as the position. Figure 1 for example may be an example of the camera and performer positions being at the 'default position' and the person responsible for the mixing indicates to the system that these are the chosen 'optimal' positions. These ideal positions may then be mapped to the current position of the microphone array to produce mapped ideal positions.

The operation of determining the ideal microphone positions/mapped ideal positions is shown in Figure 10 by step 1003.

The position determiner may furthermore receive a control parameter to control the position of the microphones.

The receiving of the control parameter is shown in Figure 10 by step 1007.

The position determiner may then compare the actual positions to the mapped ideal positions and based on the control parameter determine a controllable position/orientation between the two. Furthermore in some embodiments the position determiner may apply a spatial widening to the position based on the difference between the controllable position/orientation and the actual position.

The operation of determining the controllable position/orientation based on the actual position and the mapped ideal position and the control input (and optionally the spatial widening) is shown in Figure 10 by step 1009.

The position determiner may then output the (spatially widened) controllable position/orientation to the renderer, which may be configured to render/process an output audio signal based on the determined controllable position/orientation.

The operation of outputting the controllable position/orientation to the renderer is shown in Figure 10 by step 1011.

With respect to Figure 11 an example electronic device which may be used as the microphone array capture device and/or the position determiner is shown. The device may be any suitable electronics device or apparatus. For example in some embodiments the device 1200 is a mobile device, user equipment, tablet computer, computer, audio playback apparatus, etc.

The device 1200 may comprise a microphone array 1201. The microphone array 1201 may comprise a plurality (for example a number N) of microphones. However it is understood that there may be any suitable configuration of microphones and any suitable number of microphones. In some embodiments the microphone array 1201 is separate from the apparatus and the audio signals transmitted to the apparatus by a wired or wireless coupling. The microphone array 1201 may in some embodiments be the microphone array as shown in the previous Figures.

The microphones may be transducers configured to convert acoustic waves into suitable electrical audio signals. In some embodiments the microphones can be solid state microphones. In other words the microphones may be capable of capturing audio signals and outputting a suitable digital format signal. In some other embodiments the microphones or microphone array 1201 can comprise any suitable microphone or audio capture means, for example a condenser microphone, capacitor microphone, electrostatic microphone, Electret condenser microphone, dynamic microphone, ribbon microphone, carbon microphone, piezoelectric microphone, or microelectrical-mechanical system (MEMS) microphone. The microphones can in some embodiments output the audio captured signal to an analogue-to-digital converter (ADC) 1203.

The device 1200 may further comprise an analogue-to-digital converter 1203. The analogue-to-digital converter 1203 may be configured to receive the audio signals from each of the microphones in the microphone array 1201 and convert them into a format suitable for processing. In some embodiments where the microphones are integrated microphones the analogue-to-digital converter is not required. The analogue-to-digital converter 1203 can be any suitable analogue-to-digital conversion or processing means. The analogue-to-digital converter 1203 may be configured to output the digital representations of the audio signals to a processor 1207 or to a memory 1211.

In some embodiments the device 1200 comprises at least one processor or central processing unit 1207. The processor 1207 can be configured to execute various program codes. The implemented program codes can comprise, for example, microphone position control, position determination and tracking and other code routines such as described herein.

In some embodiments the device 1200 comprises a memory 1211. In some embodiments the at least one processor 1207 is coupled to the memory 1211. The memory 1211 can be any suitable storage means. In some embodiments the memory 1211 comprises a program code section for storing program codes implementable upon the processor 1207. Furthermore in some embodiments the memory 1211 can further comprise a stored data section for storing data, for example data that has been processed or to be processed in accordance with the embodiments as described herein. The implemented program code stored within the program code section and the data stored within the stored data section can be retrieved by the processor 1207 whenever needed via the memory-processor coupling.

In some embodiments the device 1200 comprises a user interface 1205. The user interface 1205 can be coupled in some embodiments to the processor 1207. In some embodiments the processor 1207 can control the operation of the user interface 1205 and receive inputs from the user interface 1205. In some embodiments the user interface 1205 can enable a user to input commands to the device 1200, for example via a keypad. In some embodiments the user interface 205 can enable the user to obtain information from the device 1200. For example the user interface 1205 may comprise a display configured to display information from the device 1200 to the user. The user interface 1205 can in some embodiments comprise a touch screen or touch interface capable of both enabling information to be entered to the device 1200 and further displaying information to the user of the device 1200. In some embodiments the user interface 1205 may be the user interface for communicating with the position determiner as described herein.

In some implements the device 1200 comprises a transceiver 1209. The transceiver 1209 in such embodiments can be coupled to the processor 1207 and configured to enable a communication with other apparatus or electronic devices, for example via a wireless communications network. The transceiver 1209 or any suitable transceiver or transmitter and/or receiver means can in some embodiments be

configured to communicate with other electronic devices or apparatus via a wire or wired coupling.

For example as shown in Figure 11 the transceiver 1209 may be configured to communicate with the renderer as described herein.

5 The transceiver 1209 can communicate with further apparatus by any suitable known communications protocol. For example in some embodiments the transceiver 1209 or transceiver means can use a suitable universal mobile telecommunications system (UMTS) protocol, a wireless local area network (WLAN) protocol such as for example IEEE 802.X, a suitable short-range radio frequency communication protocol
10 such as Bluetooth, or infrared data communication pathway (IRDA).

In some embodiments the device 1200 may be employed as at least part of the renderer. As such the transceiver 1209 may be configured to receive the audio signals and positional information from the microphone array/close microphones/position determiner as described herein, and generate a suitable audio signal rendering by
15 using the processor 1207 executing suitable code. The device 1200 may comprise a digital-to-analogue converter 1213. The digital-to-analogue converter 1213 may be coupled to the processor 1207 and/or memory 1211 and be configured to convert digital representations of audio signals (such as from the processor 1207 following an audio rendering of the audio signals as described herein) to a suitable analogue format
20 suitable for presentation via an audio subsystem output. The digital-to-analogue converter (DAC) 1213 or signal processing means can in some embodiments be any suitable DAC technology.

Furthermore the device 1200 can comprise in some embodiments an audio subsystem output 1215. An example as shown in Figure 11 shows the audio
25 subsystem output 1215 as an output socket configured to enabling a coupling with headphones 121. However the audio subsystem output 1215 may be any suitable audio output or a connection to an audio output. For example the audio subsystem output 1215 may be a connection to a multichannel speaker system.

In some embodiments the digital to analogue converter 1213 and audio
30 subsystem 1215 may be implemented within a physically separate output device. For example the DAC 1213 and audio subsystem 1215 may be implemented as cordless earphones communicating with the device 1200 via the transceiver 1209.

Although the device 1200 is shown having both audio capture, audio processing and audio rendering components, it would be understood that in some embodiments the device 1200 can comprise just some of the elements.

In general, the various embodiments of the invention may be implemented in hardware or special purpose circuits, software, logic or any combination thereof. For example, some aspects may be implemented in hardware, while other aspects may be implemented in firmware or software which may be executed by a controller, microprocessor or other computing device, although the invention is not limited thereto. While various aspects of the invention may be illustrated and described as block diagrams, flow charts, or using some other pictorial representation, it is well understood that these blocks, apparatus, systems, techniques or methods described herein may be implemented in, as non-limiting examples, hardware, software, firmware, special purpose circuits or logic, general purpose hardware or controller or other computing devices, or some combination thereof.

The embodiments of this invention may be implemented by computer software executable by a data processor of the mobile device, such as in the processor entity, or by hardware, or by a combination of software and hardware. Further in this regard it should be noted that any blocks of the logic flow as in the Figures may represent program steps, or interconnected logic circuits, blocks and functions, or a combination of program steps and logic circuits, blocks and functions. The software may be stored on such physical media as memory chips, or memory blocks implemented within the processor, magnetic media such as hard disk or floppy disks, and optical media such as for example DVD and the data variants thereof, CD.

The memory may be of any type suitable to the local technical environment and may be implemented using any suitable data storage technology, such as semiconductor-based memory devices, magnetic memory devices and systems, optical memory devices and systems, fixed memory and removable memory. The data processors may be of any type suitable to the local technical environment, and may include one or more of general purpose computers, special purpose computers, microprocessors, digital signal processors (DSPs), application specific integrated circuits (ASIC), gate level circuits and processors based on multi-core processor architecture, as non-limiting examples.

Embodiments of the inventions may be practiced in various components such as integrated circuit modules. The design of integrated circuits is by and large a highly automated process. Complex and powerful software tools are available for converting a logic level design into a semiconductor circuit design ready to be etched and formed on a semiconductor substrate.

Programs, such as those provided by Synopsys, Inc. of Mountain View, California and Cadence Design, of San Jose, California automatically route conductors and locate components on a semiconductor chip using well established rules of design as well as libraries of pre-stored design modules. Once the design for a semiconductor circuit has been completed, the resultant design, in a standardized electronic format (e.g., Opus, GDSII, or the like) may be transmitted to a semiconductor fabrication facility or "fab" for fabrication.

The foregoing description has provided by way of exemplary and non-limiting examples a full and informative description of the exemplary embodiment of this invention. However, various modifications and adaptations may become apparent to those skilled in the relevant arts in view of the foregoing description, when read in conjunction with the accompanying drawings and the appended claims. However, all such and similar modifications of the teachings of this invention will still fall within the scope of this invention as defined in the appended claims.

CLAIMS:

1. An apparatus for controlling a controllable position/orientation of at least one audio source within an audio scene, the audio scene comprising:
- 5 the at least one audio source;
- a capture device comprising a microphone array for capturing audio signals of the audio scene, the capture device having a capture orientation wherein the microphone array is positioned relative to the capture orientation, the apparatus comprising a processor configured to:
- 10 receive a physical position/orientation of the at least one audio source relative to the capture device capture orientation;
- receive an earlier physical position/orientation of the at least one audio source relative to the capture device capture orientation;
- receive at least one control parameter; and
- 15 control a controllable position/orientation of the at least one audio source, the controllable position being between the physical position/orientation of the at least one audio source relative to the capture device capture orientation and the earlier physical position/orientation of the at least one audio source relative to the capture device capture orientation and based on the control parameter.
- 20
2. The apparatus as claimed in claim 1, wherein the capture device further comprises at least one camera for capturing images of the audio scene, wherein the at least one camera is positioned relative to the capture orientation.
- 25
3. The apparatus as claimed in claim 2, wherein during a capture session the controllable position/orientation for the at least one audio source is defined for one of the at least one audio source between the earlier physical position/orientation which is captured on a first image of the at least one camera and the physical position/orientation which is captured on a second image of the at least one camera.
- 30
4. The apparatus as claimed in claim 3, wherein the processor configured to control the controllable position/orientation of the at least one audio source is configured to control the controllable position/orientation of the at least one audio

source relative to the capture device capture orientation such that the controllable position/orientation is the earlier physical position/orientation of the at least one audio source relative to the capture device capture orientation, such that a visually observed position/orientation of the at least one audio source differs from an audio experienced position/orientation of the at least one audio source.

5. The apparatus as claimed in any of claims 1 to 4, wherein the processor is configured to pass the controllable position/orientation of the at least one audio source to a renderer to control a mixing or rendering of an audio signal associated with the at least one audio source based on the controllable position/orientation.

6. The apparatus as claimed in any of claims 1 to 5, wherein the processor configured to receive at least one control parameter is configured to receive a weighting parameter, and the processor configured to control the controllable position/orientation is further configured to:

determine the controllable orientation based on one of the physical orientation of the at least one audio source relative to the capture device capture orientation and the earlier physical orientation of the at least one audio source relative to the capture device capture orientation which is combined with the product of the weighting parameter applied to an orientation difference between the the physical orientation of the at least one audio source relative to the capture device capture orientation and the earlier physical position/orientation of the at least one audio source relative to the capture device capture orientation; and

determine the controllable position as the intersection between a line described by the physical position of the at least one audio source relative to the capture device capture orientation and the earlier physical position of the at least one audio source relative to the capture device reference orientation and a line from the capture device at the controllable orientation.

7. The apparatus as claimed in any of claims 1 to 5, wherein the processor configured to receive at least one control parameter is configured to receive a weighting parameter, and the processor configured to control the controllable position/orientation is further configured to:

determine the controllable orientation based on one of the physical orientation of the at least one audio source relative to the capture device capture orientation and the earlier physical orientation of the at least one audio source relative to the capture device capture orientation combined with the product of the weighting parameter
5 applied to an orientation difference between the the physical orientation of the at least one audio source relative to the capture device capture orientation and the earlier physical position/orientation of the at least one audio source relative to the capture device capture orientation, and

determine the controllable position based on an arc with an origin at the capture device
10 and defined by the physical position of the at least one audio source relative to the capture device capture orientation and the earlier physical position of the at least one audio source relative to the capture device capture orientation to the capture device capture orientation and a line from the capture device at the controllable orientation.

15 8. The apparatus as claimed in any of claims 1 to 5, wherein the processor configured to receive the at least one control parameter is configured to receive a weighting parameter, and wherein the processor configured to control the controllable position/orientation is further configured to combine the product of unity minus the weighting parameter to the physical position of the at least one audio source relative
20 to the capture device capture orientation and the product of the weighting function to the earlier physical position of the at least one audio source relative to the capture device capture orientation.

9. The apparatus as claimed in any of claims 1 to 8, wherein the processor
25 configured to control the controllable position/orientation of the at least one audio source is further configured to control a width of the controllable position/orientation, the width of the controllable position/orientation being based on the distance from the physical position/orientation of at least one audio source relative to the capture device capture orientation.

30

10. The apparatus as claimed in claim 9, wherein the processor configured to control the width of the controllable position/orientation is configured to set the width of the controllable position/orientation as one half a normalised distance from the

physical position/orientation of the at least one audio source relative to the capture device capture orientation.

11. A method for controlling a controllable position/orientation of at least one audio source within an audio scene, the audio scene comprising:

the at least one audio source;

a capture device comprising a microphone array for capturing audio signals of the audio scene, the capture device having a capture orientation wherein the microphone array is positioned relative to the capture orientation, the method comprising:

receiving a physical position/orientation of the at least one audio source relative to the capture device capture orientation;

receiving an earlier physical position/orientation of the at least one audio source relative to the capture device capture orientation;

receiving at least one control parameter; and

controlling a controllable position/orientation of the at least one audio source, the controllable position being between the physical position/orientation of the at least one audio source relative to the capture device capture orientation and the earlier physical position/orientation of the at least one audio source relative to the capture device capture orientation and based on the control parameter.

12. The method as claimed in claim 11, wherein the capture device further comprises at least one camera for capturing images of the audio scene, wherein the at least one camera is positioned relative to the capture orientation.

13. The method as claimed in claim 12, wherein during a capture session the controllable position/orientation for the at least one audio source is defined for one of the at least one audio source between the earlier physical position/orientation which is captured on a first image of the at least one camera and the physical position/orientation which is captured on a second image of the at least one camera.

14. The method as claimed in claim 13, wherein controlling the controllable position/orientation of the at least one audio source comprises controlling the

controllable position/orientation of the at least one audio source relative to the capture device capture orientation such that the controllable position/orientation is the earlier physical position/orientation of the at least one audio source relative to the capture device capture orientation, such that a visually observed position/orientation of the at least one audio source differs from an audio experienced position/orientation of the at least one audio source.

15. The method as claimed in any of claims 11 to 14, further comprising passing the controllable position/orientation of the at least one audio source to a renderer to control a mixing or rendering of an audio signal associated with the at least one audio source based on the controllable position/orientation.

16. The method as claimed in any of claims 11 to 15, wherein receiving at least one control parameter comprises receiving a weighting parameter, and controlling the controllable position/orientation further comprises:

determining the controllable orientation based on one of the physical orientation of the at least one audio source relative to the capture device capture orientation and the earlier physical orientation of the at least one audio source relative to the capture device capture orientation which is combined with the product of the weighting parameter applied to an orientation difference between the the physical orientation of the at least one audio source relative to the capture device capture orientation and the earlier physical position/orientation of the at least one audio source relative to the capture device capture orientation, and

determining the controllable position as the intersection between a line described by the physical position of the at least one audio source relative to the capture device capture orientation and the earlier physical position of the at least one audio source relative to the capture device reference orientation and a line from the capture device at the controllable orientation.

17. The method as claimed in any of claims 11 to 15, wherein receiving at least one control parameter comprises receiving a weighting parameter, and controlling the controllable position/orientation further comprises:

determining the controllable orientation based on one of the physical orientation of the at least one audio source relative to the capture device capture orientation and the earlier physical orientation of the at least one audio source relative to the capture device capture orientation combined with the product of the weighting parameter applied to an orientation difference between the the physical orientation of the at least one audio source relative to the capture device capture orientation and the earlier physical position/orientation of the at least one audio source relative to the capture device capture orientation, and

determining the controllable position based on an arc with an origin at the capture device and defined by the physical position of the at least one audio source relative to the capture device capture orientation and the earlier physical position of the at least one audio source relative to the capture device capture orientation to the capture device capture orientation and a line from the capture device at the controllable orientation.

18. The method as claimed in any of claims 11 to 15, wherein receiving the at least one control parameter comprises receiving a weighting parameter, and wherein controlling the controllable position/orientation further comprises combining the product of unity minus the weighting parameter to the physical position of the at least one audio source relative to the capture device capture orientation and the product of the weighting function to the earlier physical position of the at least one audio source relative to the capture device capture orientation.

19. The method as claimed in any of claims 11 to 18, wherein controlling the controllable position/orientation of the at least one audio source further comprises controlling a width of the controllable position/orientation, the width of the controllable position/orientation being based on the distance from the physical position/orientation of at least one audio source relative to the capture device capture orientation.

20. The method as claimed in claim 19, wherein controlling the width of the controllable position/orientation comprises setting the width of the controllable position/orientation as one half the normalised distance from the physical

position/orientation of the at least one audio source relative to the capture device capture orientation.

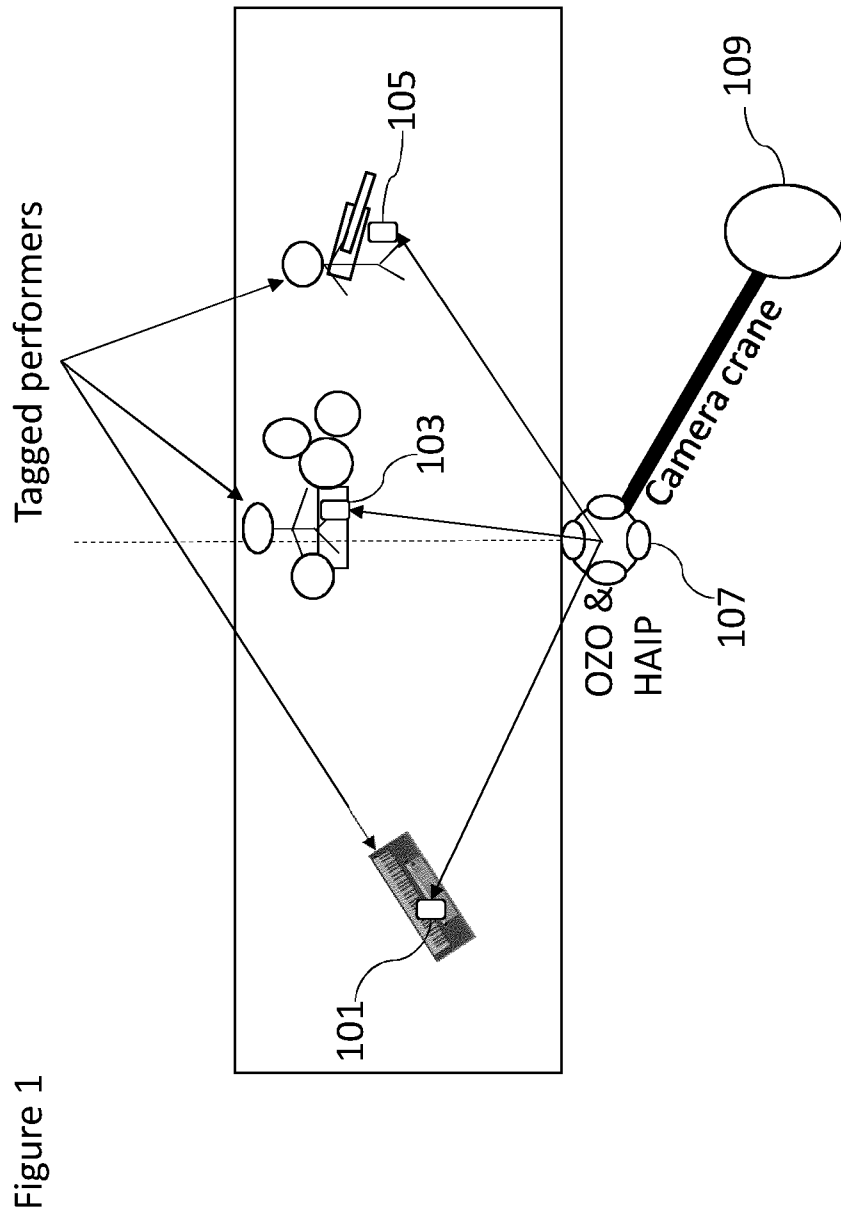

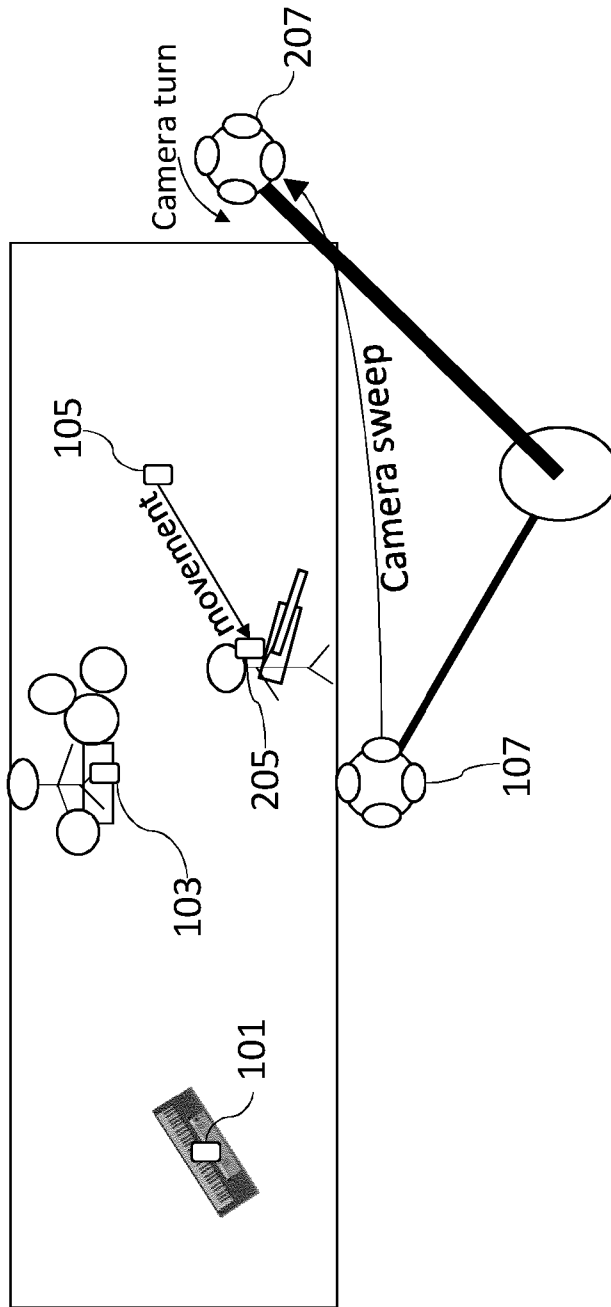

Figure 2

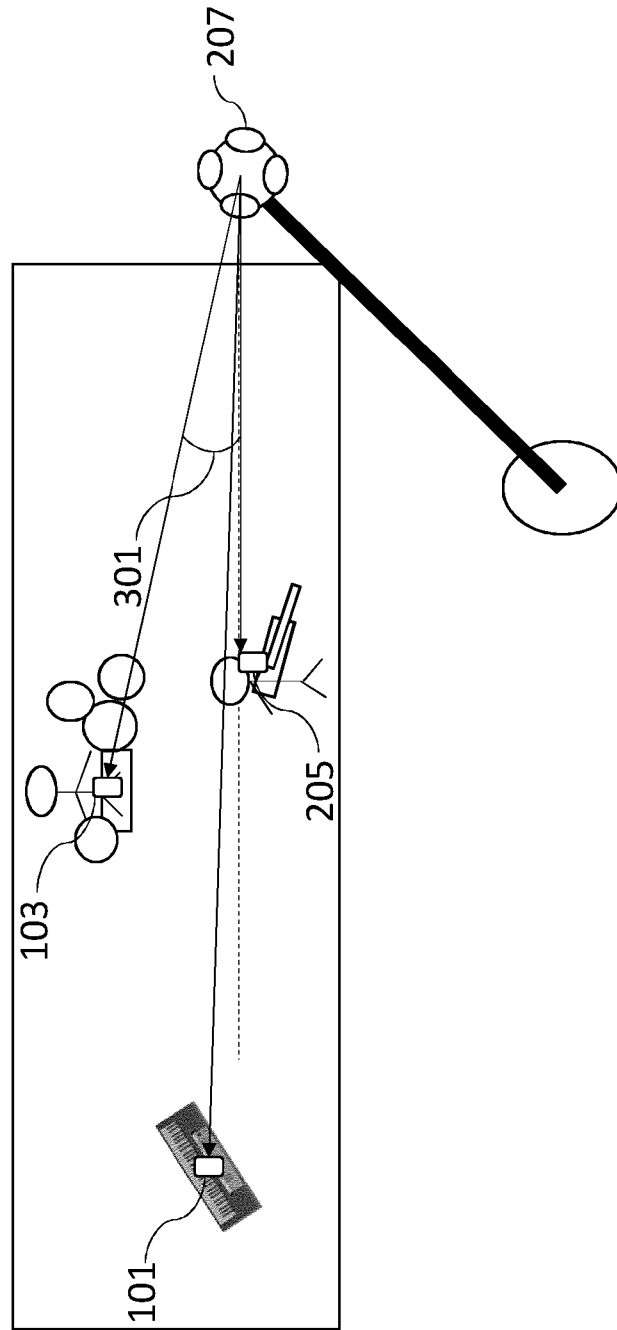

Figure 3

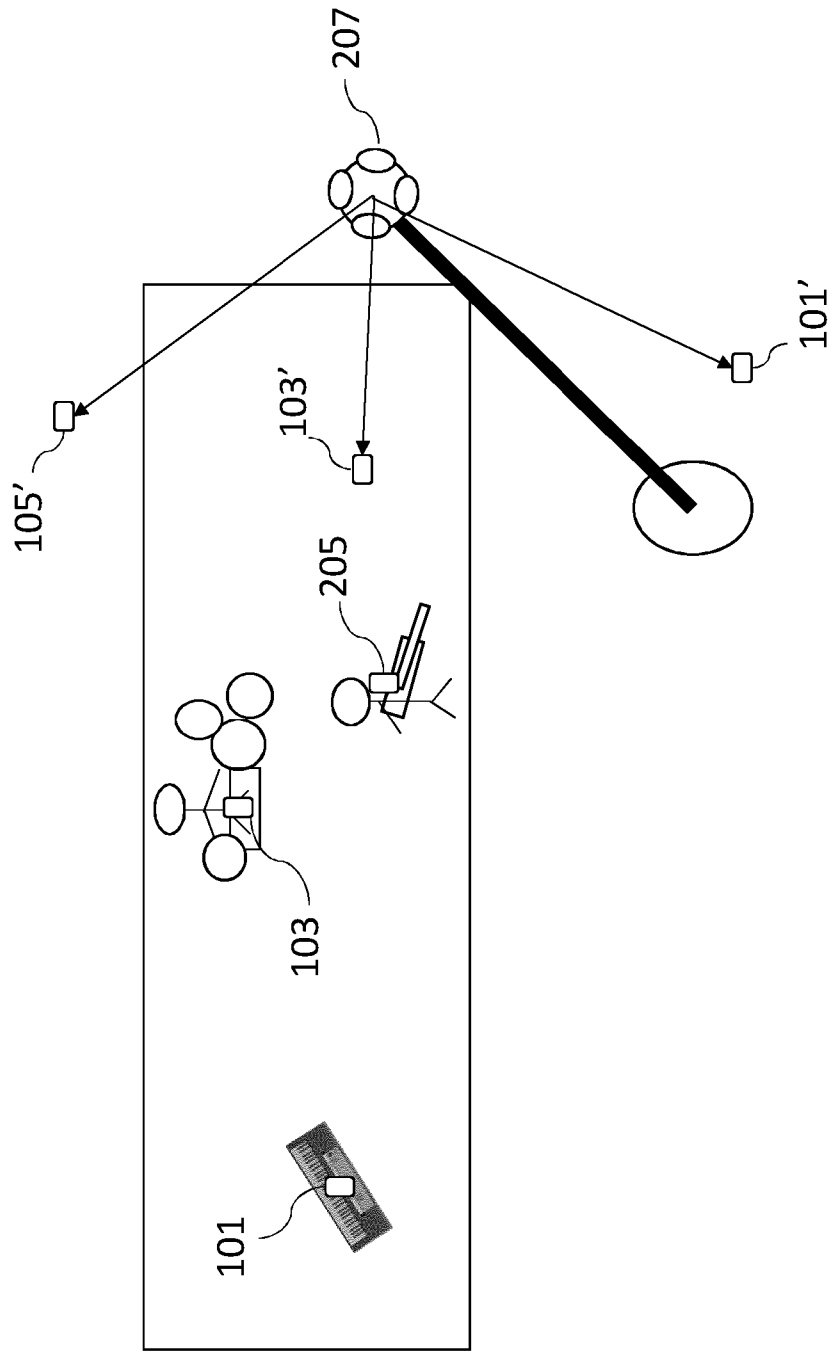

Figure 4

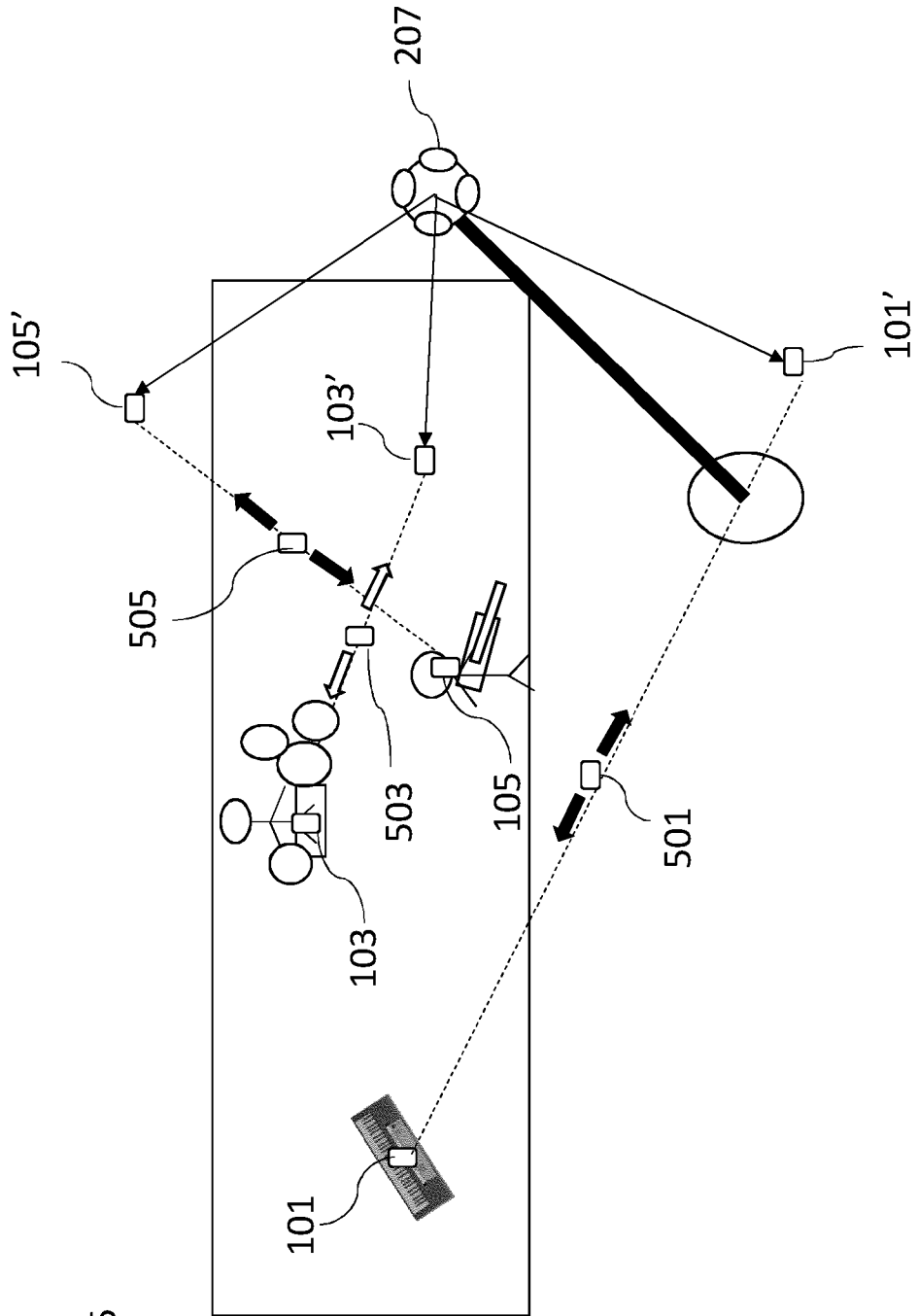

Figure 5

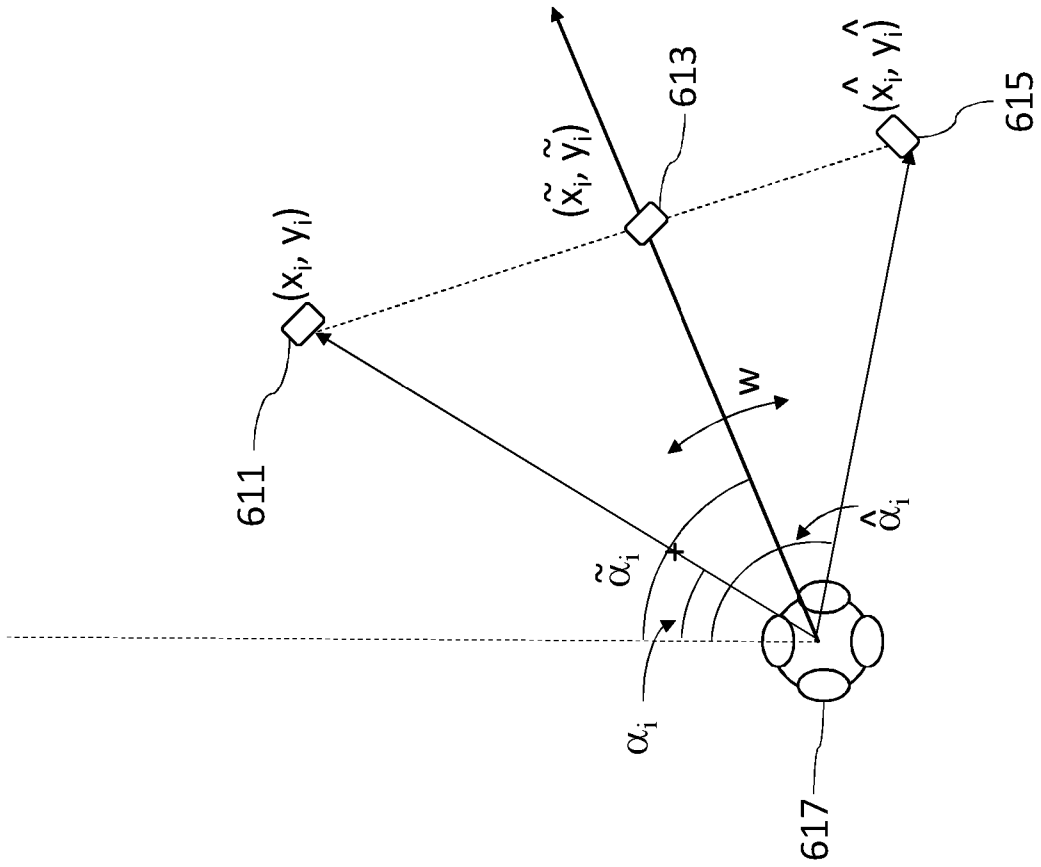
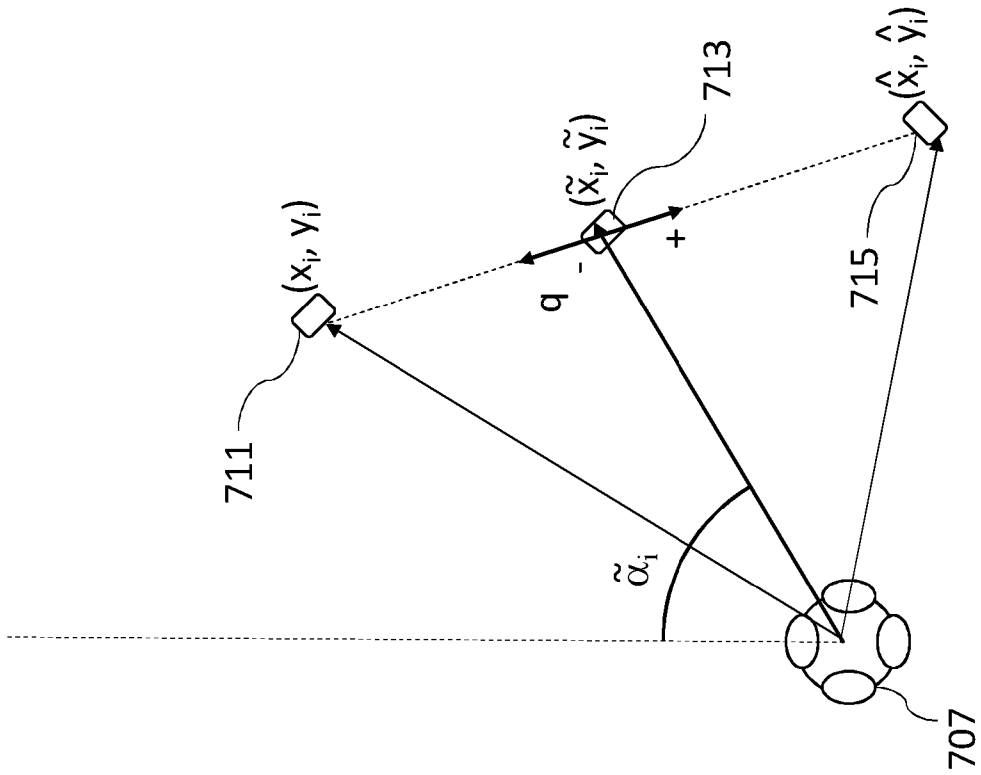

Figure 6

$$\tilde{\alpha}_i = \alpha_i - w(\alpha_i - \hat{\alpha}_i)$$



$$\tilde{x}_i = (1-q) * x_i + q * \hat{x}_i$$

$$\tilde{y}_i = (1-q) * y_i + q * \hat{y}_i$$

Figure 7

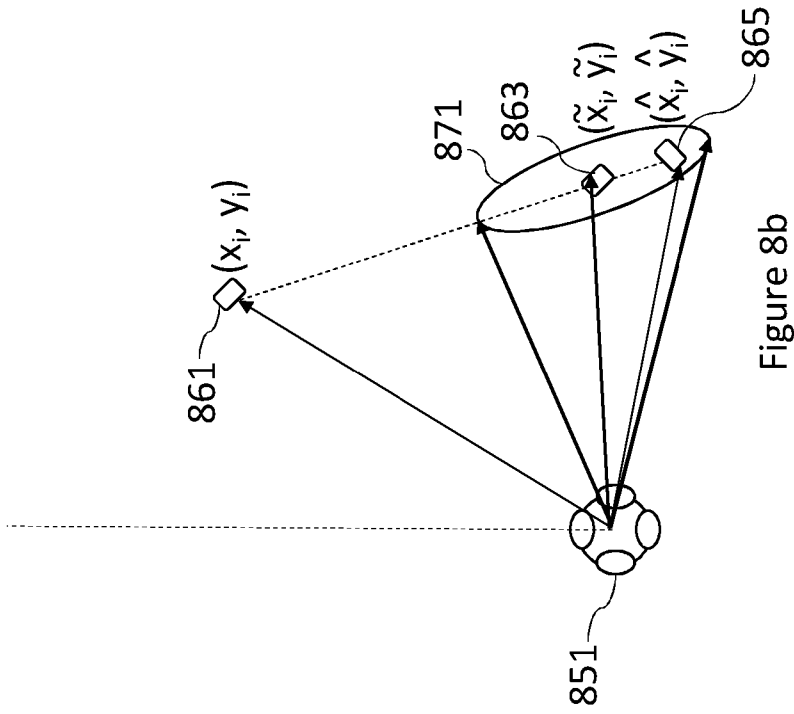

Figure 8b

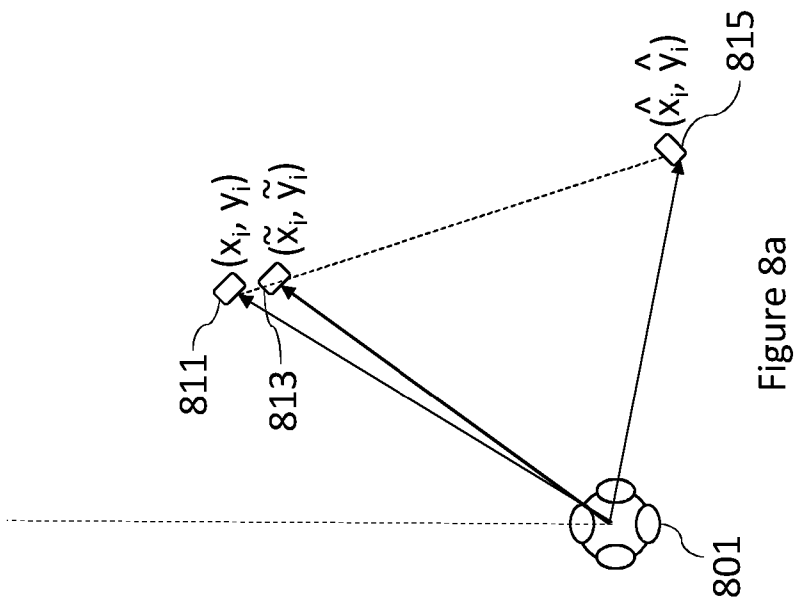

Figure 8a

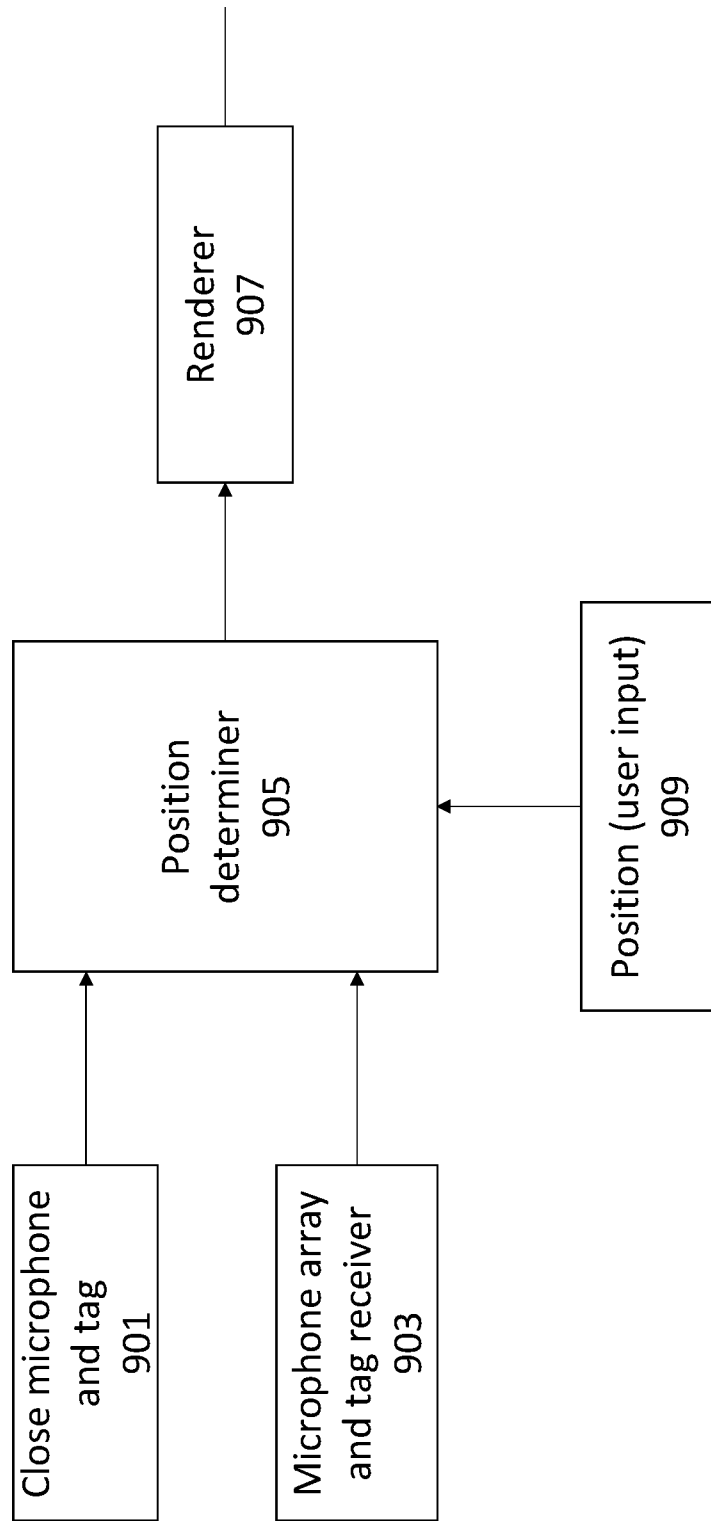

Figure 9

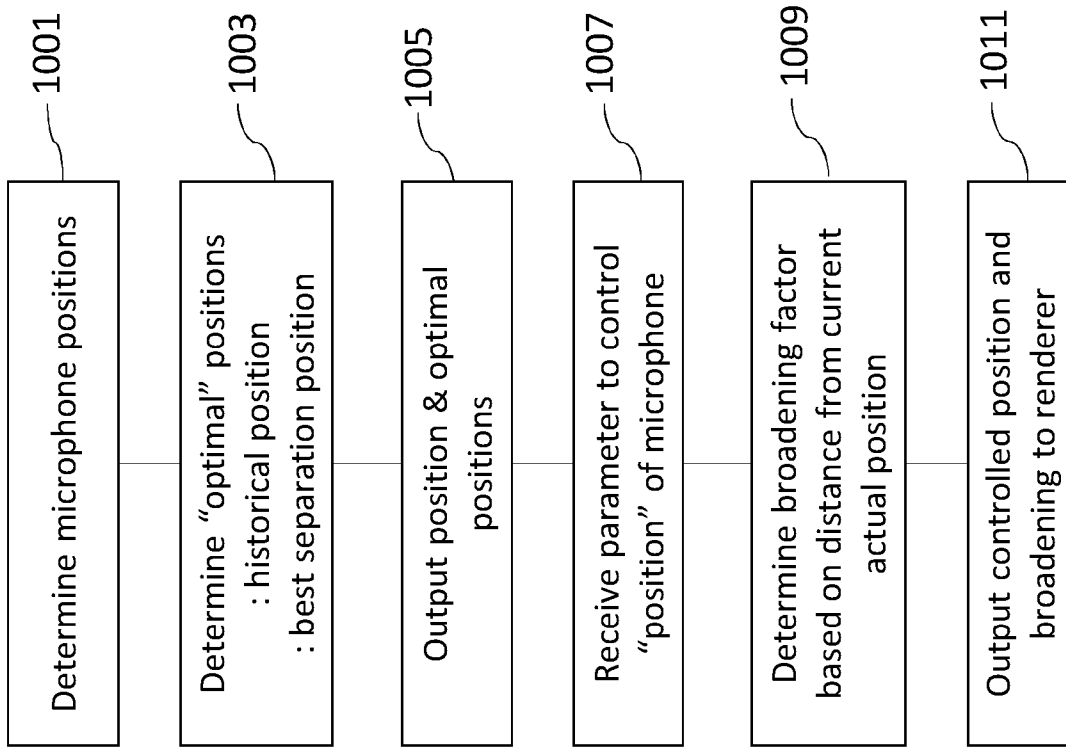

Figure 10

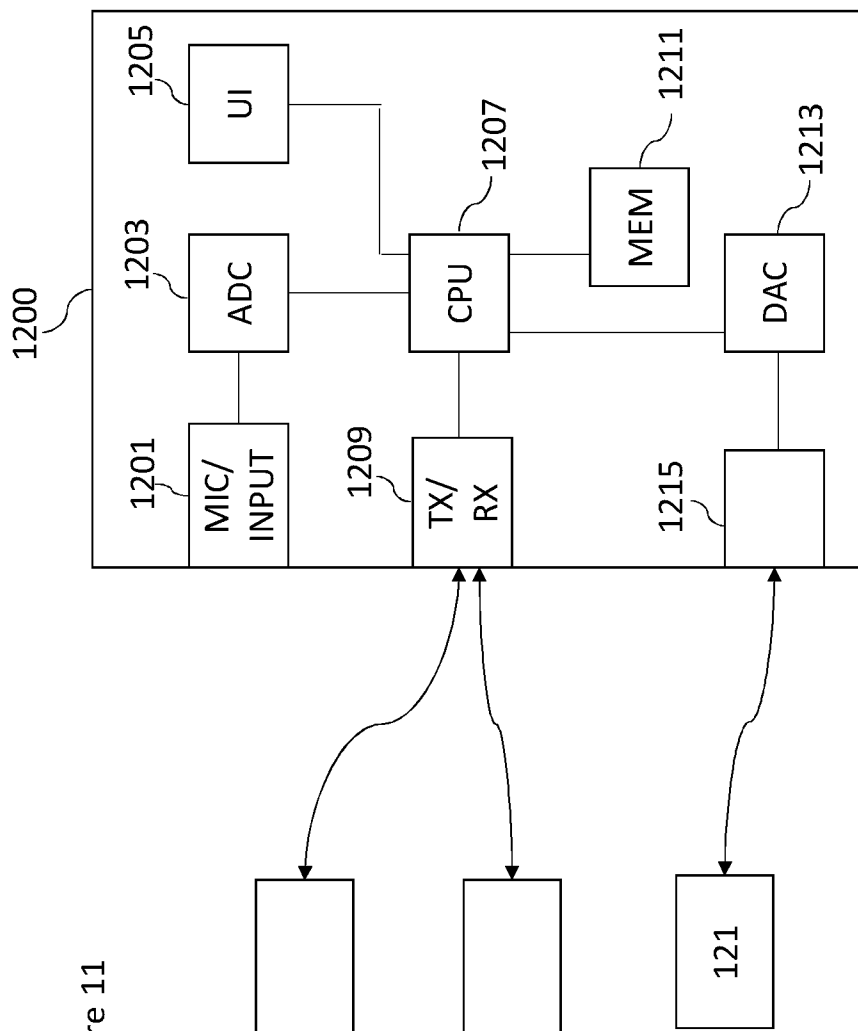

Figure 11

INTERNATIONAL SEARCH REPORT

International application No.

PCT/FI2017/050792

A. CLASSIFICATION OF SUBJECT MATTER		
See extra sheet		
According to International Patent Classification (IPC) or to both national classification and IPC		
B. FIELDS SEARCHED		
Minimum documentation searched (classification system followed by classification symbols)		
IPC: H04H, H04R, H04S, H04W, G06F, G10L		
Documentation searched other than minimum documentation to the extent that such documents are included in the fields searched		
FI, SE, NO, DK		
Electronic data base consulted during the international search (name of data base, and, where practicable, search terms used)		
EPODOC, EPO-Internal full-text databases, WPIAP, XP3GPP, XPAIP, XPESP, XPETSI, XPI3E, XPIEE, XPIETF, XPIOP, XPIPCOM, XPJPEP, XPMISC, XPOAC, XPRD, XPTK, COMPDX, INSPEC, NPL, Internet, ESPACENET		
C. DOCUMENTS CONSIDERED TO BE RELEVANT		
Category*	Citation of document, with indication, where appropriate, of the relevant passages	Relevant to claim No.
X	US 2015319530 A1 (VIROLAINEN JUSSI KALEVI [FI] et al.) 05 November 2015 (05.11.2015) Abstract, paragraphs [0005]-[0008], [0013], [0017]-[0026], [0035]-[0036], [0061]-[0063], [0065], [0075], [0079], [0081], [0091]-[0094], [0096], [0100]-[0110], [0114]-[0120], [0122]-[0128], [0141], [0147], [0162]-[0174], figures 1, 3-6, 8, 10-11.	1-5, 11-15
Y	paragraphs [0005]-[0006], [0015]-[0026], [0035]-[0036], [0063]-[0067], [0081], [0091]-[0094], [0100], [0114]-[0117], [0162]-[0173], figures 1, 3, 5, 8, 10-11	6-7, 9-10, 16-17, 19-20
A	The whole document.	8, 18
Y	US 2015156578 A1 (ALEXANDRIDIS ANASTASIOS [GR] et al.) 04 June 2015 (04.06.2015) Abstract, paragraphs [0043], [0058]-[0060], [0070]-[0072], [0075], [0085]-[0088], [0157], [0227], [0232]-[0236], [0255], figure 1.	6-7, 16-17
A	The whole document	8, 18
<input checked="" type="checkbox"/> Further documents are listed in the continuation of Box C. <input checked="" type="checkbox"/> See patent family annex.		
*	Special categories of cited documents:	
"A"	document defining the general state of the art which is not considered to be of particular relevance	"T" later document published after the international filing date or priority date and not in conflict with the application but cited to understand the principle or theory underlying the invention
"E"	earlier application or patent but published on or after the international filing date	"X" document of particular relevance; the claimed invention cannot be considered novel or cannot be considered to involve an inventive step when the document is taken alone
"L"	document which may throw doubts on priority claim(s) or which is cited to establish the publication date of another citation or other special reason (as specified)	"Y" document of particular relevance; the claimed invention cannot be considered to involve an inventive step when the document is combined with one or more other such documents, such combination being obvious to a person skilled in the art
"O"	document referring to an oral disclosure, use, exhibition or other means	"&" document member of the same patent family
"P"	document published prior to the international filing date but later than the priority date claimed	
Date of the actual completion of the international search		Date of mailing of the international search report
02 March 2018 (02.03.2018)		06 March 2018 (06.03.2018)
Name and mailing address of the ISA/FI Finnish Patent and Registration Office FI-00091 PRH, FINLAND		Authorized officer Harald Kaaja
Facsimile No. +358 29 509 5328		Telephone No. +358 29 509 5000

INTERNATIONAL SEARCH REPORT

International application No.

PCT/FI2017/050792

C (Continuation). DOCUMENTS CONSIDERED TO BE RELEVANT		
Category*	Citation of document, with indication, where appropriate, of the relevant passages	Relevant to claim No.
Y	WO 2016097477 A1 (NOKIA TECHNOLOGIES OY [FI]) 23 June 2016 (23.06.2016) Abstract, paragraphs [0041]-[0047].	9-10, 19-20
A	The whole document.	8, 18
A	US 2012295637 A1 (HANNUKSELA MISKA [FI] et al.) 22 November 2012 (22.11.2012) The whole document.	1-20
A	US 2016080886 A1 (DE BRUIJN WERNER PAULUS JOSEPHUS [NL] et al.) 17 March 2016 (17.03.2016) The whole document.	1-20

CLASSIFICATION OF SUBJECT MATTER

IPC
H04R 5/02 (2006.01)
H04R 5/033 (2006.01)
H04S 7/00 (2006.01)
H04W 4/02 (2018.01)

INTERNATIONAL SEARCH REPORT
Information on Patent Family Members

International application No.
PCT/FI2017/050792

Patent document cited in search report	Publication date	Patent family members(s)	Publication date
US 2015319530 A1	05/11/2015	US 9621991 B2 EP 2936829 A1 US 2017245053 A1 WO 2014096900 A1	11/04/2017 28/10/2015 24/08/2017 26/06/2014
US 2015156578 A1	04/06/2015	US 9549253 B2 US 9554203 B1	17/01/2017 24/01/2017
WO 2016097477 A1	23/06/2016	CN 107211216 A EP 3235264 A1 US 2016183024 A1 US 9602946 B2	26/09/2017 25/10/2017 23/06/2016 21/03/2017
US 2012295637 A1	22/11/2012	US 9008686 B2 CN 102713664 A CN 102713664 B WO 2011086419 A1	14/04/2015 03/10/2012 16/03/2016 21/07/2011
US 2016080886 A1	17/03/2016	CN 105191354 A CN 105247894 A CN 105247894 B EP 2997742 A1 EP 2997743 A1 JP 2016521532 A JP 2016525813 A RU 2015153540 A RU 2015153551 A US 2016073215 A1 US 9860669 B2 WO 2014184353 A1 WO 2014184706 A1	23/12/2015 13/01/2016 07/11/2017 23/03/2016 23/03/2016 21/07/2016 25/08/2016 21/06/2017 21/06/2017 10/03/2016 02/01/2018 20/11/2014 20/11/2014