

F. RÄHSE.

MECHANISM FOR PLAYING KEY BOARD INSTRUMENTS.

No. 443,003.

Patented Dec. 16, 1890.

Fig. 1.

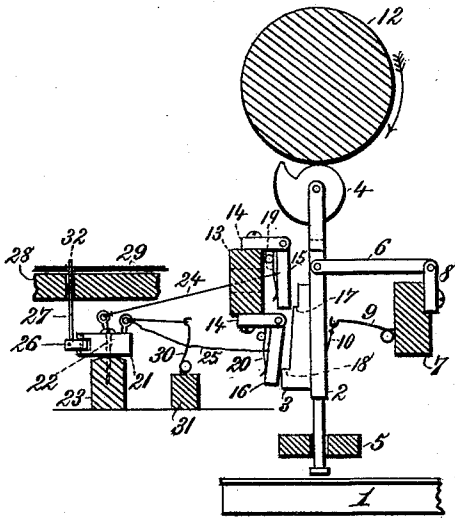

Fig. 3.

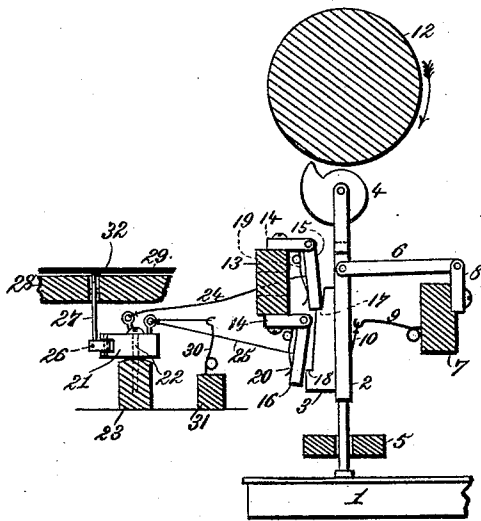

Fig. 2.

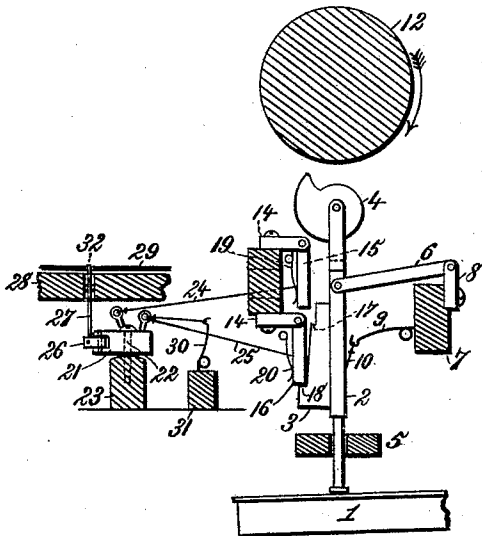
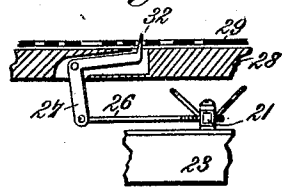

Fig. 4.



Witnesses:
Rhat Emmet,
J. A. Rutherford.

Inventor:
Ferdinand Rähse.
 By *Janus L. Norris,*
Atty.

F. RÄHSE.

MECHANISM FOR PLAYING KEY BOARD INSTRUMENTS.

No. 443,003.

Patented Dec. 16, 1890.

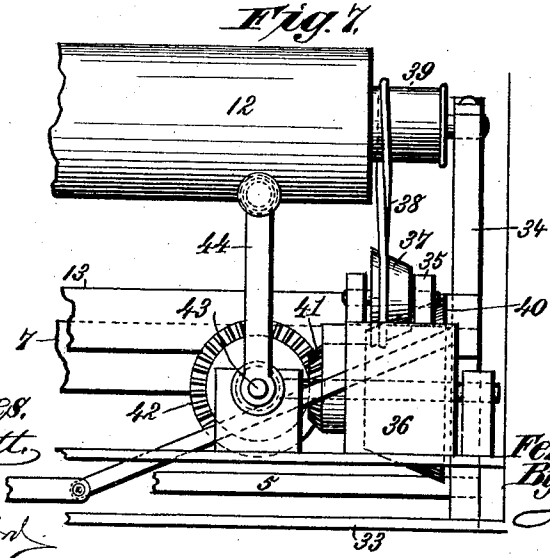
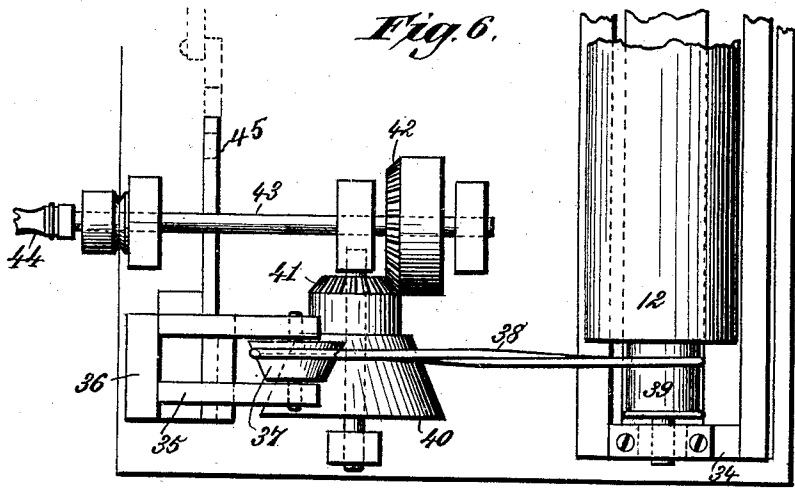
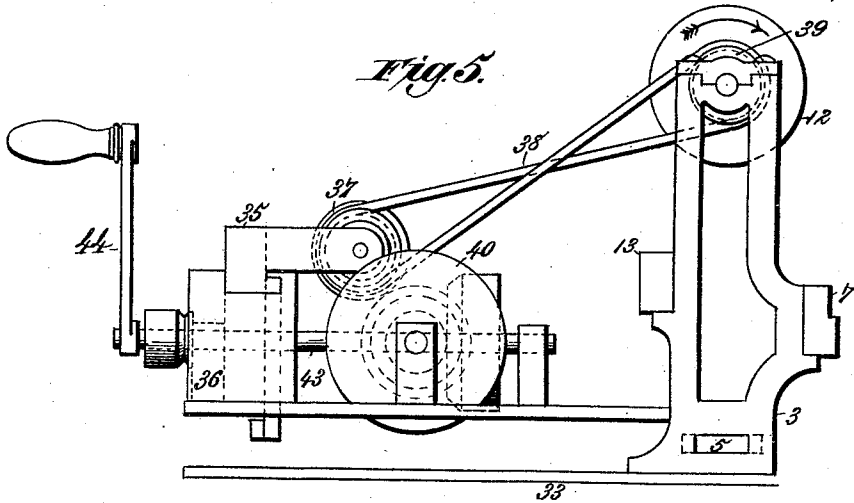

Witnesses:
Robert Everett,
J. A. Kullerford.

Inventor:
Ferdinand Rähse,
 By *James L. Norris,*
Atty.

UNITED STATES PATENT OFFICE.

FERDINAND RÄHSE, OF LÖBAU, GERMANY.

MECHANISM FOR PLAYING KEY-BOARD INSTRUMENTS.

SPECIFICATION forming part of Letters Patent No. 443,003, dated December 16, 1890.

Application filed February 28, 1890. Serial No. 342,072. (No model.)

To all whom it may concern:

Be it known that I, FERDINAND RÄHSE, manufacturer, a citizen of Germany, residing at Löbau, in the Kingdom of Saxony, Germany, have invented certain new and useful Improvements in Mechanism for Playing Key-Board Instruments; and I do hereby declare the following to be a full, clear, and exact description of the invention, such as will enable others skilled in the art to which it appertains to make and use the same.

This invention relates to means for mechanically playing key-board instruments through the medium of perforated music-sheets; and the objects of my invention are to provide novel, simple, and efficient mechanism for operating the keys of the instrument, and to provide novel means for modulating or changing the tone from piano to forte, and conversely.

To accomplish these objects my invention involves the combination or arrangement of devices and the principles of operation hereinafter described and claimed, reference being made to the accompanying drawings, in which—

Figure 1 is a detail sectional elevation of the mechanism for actuating a key, the parts being in position with the pusher-bar elevated. Fig. 2 is a similar view showing the parts in position with the pusher-bar depressing the key. Fig. 3 is a similar view showing the parts in position with the pusher-bar touching the key and in position to be elevated for its downstroke. Fig. 4 is a detail broken view showing the bell-crank playing-lever and the oscillatory lever for operating the detaining and releasing pawls. Fig. 5 is a detail end elevation of the mechanism for modulating or changing the tone from piano to forte. Fig. 6 is a detail top plan view of the same. Fig. 7 is a detail side or front elevation of the same.

In order to enable those skilled in the art to make and use my invention, I will now describe the same in detail, referring to the drawings, wherein—

The numeral 1 indicates one key of a musical instrument—for instance, a piano—and 2 a vertically-movable pusher-bar having an attached stepped block 3 and a forked upper

end, in which is journaled a snail or cam plate 4. The pusher-bar moves in a guide-piece 5 in line with the key, and by a horizontal swing-bar 6 is pivotally connected with a supporting-bar 7 through the medium of a stud or arm 8, and to the supporting-bar is secured one end of a spring 9, having its other end connected by a pivot or hinge link 10 with the pusher-bar in such manner that the spring tends to press the pusher-bar upwardly to its highest position, as in Fig. 1, to place the snail or cam plate in superficial contact with a rotating cylinder 12, whereby the latter acts by friction to whirl the snail or cam, which being eccentrically journaled, operates to suddenly or rapidly throw the pusher-bar downward against the tension of its lifting-spring.

To a supporting-bar 13 are secured upper and lower studs or arms 14, carrying pivotally-attached pendent pawls 15 and 16, adapted to respectively engage the steps 17 and 18 of the stepped block 3 and pressed toward the latter to automatically engage the steps by means of suitable springs 19 and 20. A lever 21, adapted to oscillate in a horizontal plane, is secured by a pivot-pin 22 to a support 23, and connects at opposite sides of the pivot-pin with the pawls through the medium of cords or other flexible filaments 24 and 25, and to the oscillating lever is secured a rod 26, which is pivotally connected with one arm of a pivoted bell-crank playing-lever 27, the other arm of which is extended through a music-sheet support 28, to be operated by the traveling music-sheet 29. A spring 30, secured to a support 31, is connected with the oscillatory lever 21, and such spring is of greater power than the pawl-pressing springs 19 and 20, for a purpose that will hereinafter appear.

The arm of the playing-lever, which extends through the music-support 28, is formed into a finger-piece 32 in such manner that at the commencement of the performance an imperforate part of the music-sheet, acting on the finger-piece 32, presses the playing-lever downward, thereby causing the rod 26 to swing the lever 21 and retract the lower pawl 16 from the step 18, whereupon the pusher-bar will by the spring 9 be thrown upwardly until the upper step 17 is engaged by the

upper pawl 15. When one of the usual note-perforations in the music-sheet coincides with the finger-piece of the playing-lever, the tension of the spring 30 swings the oscillatory lever and the finger-piece of the playing-lever is snapped into such note-perforation and the upper pawl 15 is disengaged from the step 17, since the power of the spring 30 overcomes the pawl-spring 19. The instant this occurs the spring 9 throws the pusher-bar upward and places its snail or cam in contact with the surface of the rotating cylinder, as in Fig. 1, whereupon the cylinder suddenly whirls the snail in the direction of the arrow. Thereupon and in consequence of the eccentric arrangement of the snail the pusher-bar is thrown downward and operates the key to produce a quaver. The instant the step 18 passes the lower end of the pawl 16 in the descent of the pusher-bar to operate the key such pawl springs into engagement with said step, thereby holding or detaining the pusher-bar and key depressed, Fig. 2, so long as the finger-piece of the playing-lever 27 remains in the note-perforation of the music-sheet; but immediately on the playing-lever being depressed by the music-sheet the pawl 16 is withdrawn from the step 18, the pusher-bar rises, and pawl 15 is thrown into engagement with the step 17 to detain the pusher-bar against the tension of the spring 9 until another note-perforation releases the playing-lever when the operation is repeated.

I will now describe the modulating mechanism whereby the tone is changed from piano to forte and conversely, reference being made to Figs. 5, 6, and 7, where the numeral 33 indicates a bed-piece, which may be a part of a frame-work comprising the supports 5, 7, and 13, hereinbefore alluded to. To the bed-piece 33 is attached standards 34, on which the cylinder 12 is journaled, and in a movable carrier 35, on a support 36, is journaled a conical pulley 37, geared by a crossed belt 38 with a pulley 39 on a shaft of the cylinder. The conical pulley 37 has an annular groove for the belt and bears against and is rotated by frictional contact with a conical pulley 40 of greater diameter, having at one end a hub provided with an attached bevel gear-wheel 41, that meshes into a bevel gear-wheel 42 on a shaft 43, having a crank-handle 44 or any othersuitable means for rotating it, and thereby imparting rotary motion to the pulleys 40 37 and by belt 38 to the pulleys 39 of the cylinder.

The carrier 35 can be moved rectilinearly back and forth through the medium of a rod 45, and consequently the velocity of the conical pulley 37 can be changed at any time by operating the rod 45 in any desired manner to slide the carrier, and thereby cause the conical pulley 37 to move along the conical pulley 40 to or from the greatest diameter of the latter. By this means the speed of the cylinder 12 can be varied at will to whirl the snail or cam 4 more or less rapidly, and thereby

vary the speed or rapidity with which the pusher-bar is thrown downward to lessen or increase the force of the stroke in a manner similar to touching the key with the finger. The tone is thus modulated or varied from piano to forte at will, and the music approximates that produced by professionals with key-board instruments.

Having thus described my invention, what I claim is—

1. The combination of a vertically-sliding pusher-bar having a snail or cam journaled on its upper end and adapted to touch and operate a key at its lower end, a rotating cylinder for whirling the snail or cam to depress the pusher-bar, pawls for detaining the pusher-bar depressed and releasing it to rise, a spring for lifting the pusher-bar when released by the pawls, and a playing-lever operated by a music-sheet and connected with and operating the pawls, substantially as described.

2. The combination of a reciprocating pusher-bar having at its upper end a journaled snail or cam and adapted at its lower end to touch and operate a key, a rotating cylinder for whirling the snail or cam to throw the pusher-bar downward to touch and operate a key, mechanism operated by a music-sheet for holding the pusher-bar depressed and releasing it to rise and place the snail or cam against the rotating cylinder, and a spring for lifting the pusher-bar when released, substantially as described.

3. The combination of a reciprocating key-operating pusher-bar, means for throwing the pusher-bar downward to touch or operate a key, means for automatically detaining, releasing, and elevating the pushing-bar, and modulating mechanism which varies the speed of the downstroke of the pusher-bar, substantially as described.

4. The combination of a reciprocating key-operating pusher-bar having a snail or cam, rotating cylinder for whirling the cam and throwing the pusher-bar downward to touch or operate a key, a playing-lever, intermediate mechanism for detaining and releasing the pusher-bar, and modulating mechanism which at will varies the speed of the cylinder, substantially as described.

5. The combination of a reciprocating key-operating pusher-bar, a playing-lever, means for detaining, releasing, and elevating the pusher-bar, and mechanism for throwing the pusher-bar downward at varying speed to modulate the tone, substantially as described.

6. The combination of a pusher-bar having a snail or cam and a stepped block, a rotating cylinder for whirling the snail or cam, pawls which detain and release the stepped block, an oscillating lever flexibly connected with the pawls, and a playing-lever which actuates the oscillating lever, substantially as described.

7. The combination of a pusher-bar having a stepped block, means for reciprocating the

pusher-bar, detaining and releasing pawls for
the stepped block, an oscillating lever flexi-
bly connected with the pawls, and a playing-
lever connected with the oscillating lever,
5 substantially as described.

8. The combination of a reciprocating
spring-raised pusher-bar and mechanism for
varying its rapidity of stroke toward the key,
with means controlled by a music-sheet for
10 detaining and releasing the pusher-bar, sub-
stantially as described.

9. The combination, with a reciprocating
pusher-bar, a cylinder for throwing the same
toward the key, and mechanism controlled by

a music-sheet for detaining and releasing the 15
pusher-bar, of conical pulleys arranged in
frictional contact and one belted to the cyl-
inder, gearing for driving the pulleys, and
means for laterally adjusting one of the pul-
leys to vary the speed of the pusher-bar to- 20
ward the key, substantially as described.

In testimony whereof I affix my signature in
presence of two witnesses.

FERDINAND RÄHSE.

Witnesses:

CARL FR. REICHERT,
PAUL DRUCKMÜLLER.