



- (51) International Patent Classification:
C03B 3/00 (2006.01) C03B 5/20 (2006.01)
- (21) International Application Number:
PCT/US2015/027440
- (22) International Filing Date:
24 April 2015 (24.04.2015)
- (25) Filing Language: English
- (26) Publication Language: English
- (30) Priority Data:
14/262,113 25 April 2014 (25.04.2014) US
- (71) Applicant: OWENS-BROCKWAY GLASS CONTAINER INC. [US/US]; One Michael Owens Way, Perrysburg, OH 43551 (US).
- (72) Inventors: WANG, Zhongming; 4686 Sycamore Drive, Ypsilanti, MI 48197 (US). WEIL, Scott; 6436 Brixton Road, Apt 7, Maumee, OH 43537 (US). GULLINKALA, Tilak; 5343 Hollengbeck Drive, Perrysburg, OH 43551 (US). VEMPATI, Udaya; 13355 Roachton Road, #7, Perrysburg, OH 43551 (US). KADUR, Shivakumar, S.; 4950 Prestonwood Road, Perrysburg, OH 43551 (US).
- (74) Agent: SMITH, Susan, L.; Owens-illinois, Inc., One Michael Owens Way, Perrysburg, OH 43551 (US).

- (81) Designated States (unless otherwise indicated, for every kind of national protection available): AE, AG, AL, AM, AO, AT, AU, AZ, BA, BB, BG, BH, BN, BR, BW, BY, BZ, CA, CH, CL, CN, CO, CR, CU, CZ, DE, DK, DM, DO, DZ, EC, EE, EG, ES, FI, GB, GD, GE, GH, GM, GT, HN, HR, HU, ID, IL, IN, IR, IS, JP, KE, KG, KN, KP, KR, KZ, LA, LC, LK, LR, LS, LU, LY, MA, MD, ME, MG, MK, MN, MW, MX, MY, MZ, NA, NG, NI, NO, NZ, OM, PA, PE, PG, PH, PL, PT, QA, RO, RS, RU, RW, SA, SC, SD, SE, SG, SK, SL, SM, ST, SV, SY, TH, TJ, TM, TN, TR, TT, TZ, UA, UG, US, UZ, VC, VN, ZA, ZM, ZW.
- (84) Designated States (unless otherwise indicated, for every kind of regional protection available): ARIPO (BW, GH, GM, KE, LR, LS, MW, MZ, NA, RW, SD, SL, ST, SZ, TZ, UG, ZM, ZW), Eurasian (AM, AZ, BY, KG, KZ, RU, TJ, TM), European (AL, AT, BE, BG, CH, CY, CZ, DE, DK, EE, ES, FI, FR, GB, GR, HR, HU, IE, IS, IT, LT, LU, LV, MC, MK, MT, NL, NO, PL, PT, RO, RS, SE, SI, SK, SM, TR), OAPI (BF, BJ, CF, CG, CI, CM, GA, GN, GQ, GW, KM, ML, MR, NE, SN, TD, TG).

Published:
— with international search report (Art. 21(3))

(54) Title: GLASS FURNACE

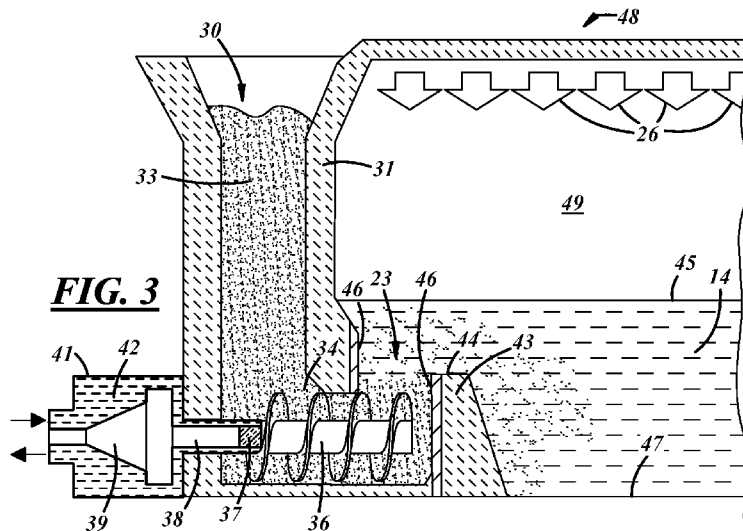

(57) Abstract: A glass furnace (10, 48, 55, 75) includes a furnace melt chamber (12, 49, 56, 82) to contain a glass melt (14) having a top surface, and a batch feeder (16, 36, 53, 78) to receive glass batch material and feed said material to the furnace melt chamber below the level of the glass melt top surface.

WO 2015/164694 A1

GLASS FURNACE

[0001] The present disclosure is directed to an arrangement for feeding glass batch material into a furnace at a location below glass melt level to eliminate problems associated with the batch blanket that is otherwise formed on the top surface of the glass melt.

Background and Summary of the Disclosure

[0002] Typically, the natural gas burners that provide energy for a glass melting furnace are located in the walls of the furnace. The flames from the burners extend across the width or the length of the furnace, slightly above and approximately parallel to the top surface of the glass melt within the furnace. Heat energy is transferred from the burner flames to the top surface of the glass melt primarily by conduction and radiation. In a typical furnace, raw batch materials are added to the furnace by distributing the raw materials on top of the existing glass melt, creating a batch 'blanket' of raw materials on the top surface of the glass melt. The raw batch materials consist of dry particles, ranging in grain size from approximately 0.02 to 1.0 mm.

[0003] Adding the raw batch materials into a glass furnace in this manner presents several operational difficulties. First, the dry batch materials are poor conductors of heat due to their low heat transfer coefficients and radiation emissive factors. As a result, the blanket of raw batch materials on the surface of the melt functions as an insulating layer that decreases the amount of heat energy that is transferred from the burners to the glass melt.

[0004] Another issue is the disturbance of the dry materials by the glass burner flames. The flow of air from the flames causes turbulence that disturbs and picks up the dry materials. The dry materials become entrained in the exhaust gases that exit the furnace flue or stack, a situation referred to as 'batch carryover', resulting in environmental air emissions such as opacity and

particulate matter emissions. A third issue caused by the blanket of dry batch materials is the loss of light chemical elements such as sodium from the glass melt due to volatilization of these light elements. The loss of batch materials due to carryover or volatilization alters the chemistry of the glass melt, resulting in a final glass chemistry that is outside of the desired chemical specification, which alters the properties of the final glass product. To avoid these problems with dry batches, glass melting furnace feedstock is typically wetted with water (0-5% by weight). Although batch wetting mitigates many of the problems discussed herein, it can cause others such as poor batch transport conditions, segregation, and additional energy consumption in the glass melting furnace to drive off the added water.

[0005] A general object in accordance with one aspect of the disclosure is to provide a raw batch material feeder for glass furnaces that eliminates the raw batch material blanket that may be formed on the top surface of the melt when batch material is fed onto the top surface of the melt, and the problems associated with such a batch blanket.

[0006] Another object in accordance with another aspect of the disclosure is to eliminate the raw batch material blanket that reduces the amount of heat energy that is transferred from the gas burners to the glass, thereby increasing the efficiency of the furnace, by increasing the amount of heat energy that is transferred from the burner flames to the glass melt.

[0007] Another object in accordance with another aspect of the disclosure is to eliminate the loss of light chemical elements such as sodium from glass melt due to volatilization at high temperature.

[0008] A still further object in accordance with another aspect of the disclosure is to eliminate batch carryover. The present disclosure embodies a number of aspects that can be implemented separately from, or in combination with, each other.

A glass furnace in accordance with one aspect of the disclosure includes a furnace melt chamber to contain a glass melt having a top surface; and a batch feeder to receive glass batch material and feed said material to the furnace melt chamber below the level of the glass melt top surface.

Brief Description of the Drawings

[0009] The disclosure, together with additional objects, features, advantages and aspects thereof, will be best understood from the following description, the appended claims and the accompanying drawings, in which:

[00010] FIG. 1 is a schematic top view of a glass melting furnace having feed chutes for batch material connected to a bottom portion of the furnace.

[00011] FIG. 2 is a side view of the glass melting furnace of FIG. 1 showing the feed chutes and the feed path for batch material fed into the bottom portion of the furnace.

[00012] FIG. 3 is a side view of another illustrative embodiment of a glass melting furnace having a side mounted hopper that supplies batch material to a horizontal screw feeder and a batch material heater in a well that are located proximate to a bottom of the furnace.

[00013] FIG. 4 is a side view of another illustrative embodiment of a glass melting furnace having a side mounted hopper that supplies batch material to a vertical screw feeder and a batch material heater and well that are located proximate the bottom of the furnace.

[00014] FIG. 5 is a side view of another illustrative embodiment of a glass melting furnace having submerged burners and a side mounted hopper that supplies batch material to a horizontal screw feeder located proximate a bottom of the furnace.

Detailed Description of Preferred Embodiments

[00015] FIG. 1 illustrates a schematic top view of a glass melting furnace generally designated by the reference numeral 10. The furnace has a furnace melt chamber 12 for melting the raw batch materials which in operation contains a pool 14 of molten glass as understood by those skilled in the art. One or more batch feed chutes 16 may be connected to the furnace 10, for example, at a bottom portion thereof. A batch feed inlet 17 may be coupled to each batch feed chute 16 for the introduction of raw batch materials to the feed chute. Each of the batch feed chutes 16 may contain a batch feeder, for example, a screw conveyor 18. Each of the batch feed chutes 16 may be coupled to a heater 20 having an outlet 21 as more fully described below. A dam wall 22 may be disposed between the screw conveyor 18 and the melt chamber 12. The dam wall 22 creates a well 23 or a series of wells prior to the melt chamber 12 and may contain the heaters 20. The dam wall 22 may be positioned between the heater outlets 21 and the remainder of the furnace and separates the heaters 20 and the heater outlets 21 from the remaining volume of the furnace 10.

[00016] FIG. 2 is a side view of the glass melting furnace 10 of FIG. 1 showing one of the batch feed chutes 16 and a feed path for raw batch materials fed into the furnace 10. Heat in the furnace 10 may be provided by top mounted heating elements 26 which may be powered by natural gas. Other types of heating elements may be used and in any suitable locations. An outlet of the feed chute 16 may be coupled to the heater 20.

[00017] The heater 20 may comprise an enclosure 19 which may have an outlet 21 on the top thereof, and a heating element contained within the enclosure 19. The heating element may comprise a gas or an electric heater element as desired. The heater 20 may also include an internal screw conveyor 24. The screw conveyor 24 may provide a flow of the raw batch

material from the screw conveyor 18 of the feed chute 16 to the heater outlet 21. The heater 20 may be positioned in the well 23 within the furnace prior to the glass melt chamber 12 that may be established by the dam wall 22.

[00018] The dam wall 22 creates a well 23 in which the raw batch materials are heated and partially melted by the heaters in the well 23 before the batch flows over the dam wall 22 and enters the main volume of the furnace melt chamber 12. The top 27 of the dam wall 22 may be below the top surface of the glass melt level 28 in the furnace melt chamber 12. The melt level 28 may be an upper surface of the molten glass in the chamber 12.

[0004] In operation, raw batch materials are fed into the feed inlet 17 and the screw conveyor 18 transports the raw batch materials through the feed chute 16 into the heater 20. The heater 20 heats and partially melts at least some of the raw batch materials and the conveyor 24 in the heater 20 drives the batch material to the heater outlet 21 and into the lower portion of the well 23 formed by the dam wall 22 for partial melting prior to entering the melt chamber 12. The partially melted raw batch materials flow upward over the dam wall 22 out of the well 23 and into the furnace melt chamber 12.

[00019] The dam wall 22 creates a well in which CO₂ may be released from the raw materials as the heaters 20 provide heat to, and partially melt, the raw materials. The release of CO₂ from the raw materials in the well reduces the amount of CO₂ bubbles that may form in the glass as the raw materials fully melt in the melt chamber 12. The removal of CO₂ bubbles from the molten glass is referred to as refining. Removal of the CO₂ in the well reduces the amount of time required to refine the glass in the melt chamber. As more partially melted batch material flows from the heater outlet 21 into the well 23, the melted batch material flows over the top 27 of the dam wall 22 into the melt pool 14 contained in the furnace melt chamber 12.

[00020] The height of the dam wall 22 can be varied to obtain different objectives. A short dam wall 22 will protect the feeder mechanism. A mid-height dam wall 22 will cause the batch material to be fed in the middle of the melt pool 14, or at the top surface of the melt pool 14. The percentage of batch material that is melted by the heater 20 in the mix of melted and unmelted batch material that flows over the dam wall 22 can be varied from approximately 25% to 75%, and more particularly from 40% to 50%, as desired.

[00021] FIG. 3 shows another illustrative embodiment of a glass melting furnace 48. This embodiment is similar in many respects to the embodiment of FIGS. 1-2, and like numerals among the embodiments generally designate like or corresponding elements throughout the several views of the drawing figures. Accordingly, the descriptions of the embodiments are incorporated into one another, and description of subject matter common to the embodiments generally may not be repeated here.

[00022] The glass melting furnace 48 has a chamber 49 in which a hopper 30 may be positioned adjacent to a wall 31 of the furnace melt chamber 49. The hopper 30 contains raw batch material 33 which is fed by gravity to a feed chamber 34 containing a screw conveyor 36, which may be carried at a level that is proximate a bottom portion 47 of the furnace 48. As used herein, the terminology proximate a bottom portion 47 may include at the bottom portion 47 or spaced apart therefrom but closer to the bottom than the top or at a position below the top surface of the molten glass pool 14 within the furnace melt chamber 49.

[00023] The screw conveyor 36 may be coupled by a high thermal resistance joint 37 to the output shaft 38 of a motor 39 contained in a motor housing 41. The motor housing 41 may be coupled to a source of cooling fluid 42 that circulates through the housing 41 to maintain the motor 39 at an acceptable operating temperature. The batch feed chamber 34 may be separated

from the rest of the furnace melt chamber 49 by a dam wall 43. A top 44 of the dam wall 43 may be below the top surface of the melt level 45 in the furnace melt chamber 49. The height of the dam wall 43 can be varied to obtain different objectives. A short dam wall 43 will protect the screw conveyor 36 from the high temperatures of the melt pool 14 in the furnace melt chamber 49. A mid-height dam wall 43 will cause the batch material to be fed into the middle of the melt pool 14, and a high dam wall 43 will cause the batch material to be fed into the upper portion of the melt pool 14.

[00024] A heater 46 may be provided to heat the batch material in the feed chamber 34 and well 23 before it is driven over the top 44 of the dam wall 43. The heater 46 may span the gap between the dam wall 43 and the wall 31 of the furnace melt chamber 49 so that batch material exiting the feed chamber 34 may be forced through the heater 46. Alternatively, the heater 46 may be positioned on the side of the dam wall 43 facing the incoming batch material, and on the side of the furnace wall 31 that is in contact with the batch material within the well 23 so that batch material exiting the feed chamber 34 may be forced past the heater 46, or the heater 46 may be located in any other position. The heater 46 may be an electric heater, an induction heater, a gas radiation tube, or other suitable heating device.

[00025] In operation, gravity feeds batch material 33 from the hopper 30 into the feed chamber 34, and rotation of the screw conveyor 36 by the motor 39 drives the raw batch material 33 through the feed chamber 34 and upward through or past the heater 46. The heater 46 heats and partially melts at least some of the raw batch material 33 before it is introduced into the melt pool 14 in the furnace melt chamber 49. The outlet of the heater 46 may be below the melt level 45 in the furnace.

[00026] FIG. 4 shows an alternative embodiment of a glass melting furnace 55 having a furnace melt chamber 56 and a side mounted hopper 50 that supplies batch material 33 to a feed chamber that is part of a well 51 formed by a dam wall 52 located in the furnace melt chamber 56. The well 51 contains a vertical screw conveyor 53 that is located proximate the bottom wall 54 of the furnace 55, and heater elements 57 and 58 that are located on the side of the dam wall 52 and the side wall 59 of the furnace 55, respectively. Heat in the furnace 55 may be provided by top mounted heating elements 26. The batch material 33 in the hopper 50 is fed by gravity to a feed channel 61 having a sloped bottom feed wall 62 that is angularly related to the vertical side wall 63 of the hopper 50 and the bottom wall 54 of the furnace 55. The sloped bottom feed wall 62 may be angled between 30° and 60° to the bottom wall 54 of the furnace 55, and the sloped bottom feed wall 62 aids in maintaining an even flow of batch material 33 to the vertical screw conveyor 53.

[00027] The vertical screw conveyor 53 is arranged to convey batch material 33 upward from the well 51 to a top 64 of the dam wall 52. The vertical screw conveyor 53 may be coupled by a high thermal resistance joint 37 to the output shaft 38 of a motor 39 contained in a motor housing 41. The motor housing 41 may be coupled to a source of cooling fluid 42 that circulates through the motor housing 41 to maintain the motor 39 at an acceptable operating temperature. The well 51 is separated from the furnace melt chamber 56 by the dam wall 52. The top 64 of the dam wall 52 may be below a melt level 45 in the furnace melt chamber 56. The heater elements 57 and 58 heat the batch material flowing upward from the well 51 over the top 64 of the dam wall 52 into the melt pool 14 in the furnace melt chamber 56. The heater elements 57 and 58 may be an electric heater, an induction heater, a gas radiation tube, or other suitable heating device.

[00028] FIG. 5 shows another embodiment of a glass melting furnace 75 having a furnace melt chamber 82 including a side wall 81 and a bottom wall 79. The furnace melt chamber 82 contains a melt pool 14 of glass having a melt level 88. A batch feed hopper 77 is positioned adjacent to the side wall 81 of the furnace melt chamber 82 to supply batch material 33 under gravity to the bottom 84 of the hopper 77. A feed opening 87 in the side wall 81 of the furnace melt chamber 82 feeds batch material 33 from the bottom 84 of the hopper to the melt pool 14 of glass below the melt level 88. A screw conveyor 78 proximate the bottom wall 90 of the hopper 77 feeds the batch material 33 from the bottom 84 of the hopper 77 through the feed opening 87 and into the furnace melt chamber 82. The screw conveyor 78 is oriented generally horizontally proximate the bottom wall 90 of the hopper. Submerged heaters 76 proximate the bottom wall 79 of the furnace melt chamber 82 heat the melt pool 14 of glass in the furnace melt chamber 82. The feed opening 87 defines a plane and is positioned below the melt level 88 in furnace melt chamber 82. The screw conveyor 78 may be coupled by a high thermal resistance joint 37 to the output shaft 38 of a motor 39 contained in a motor housing 41. The motor housing 41 may be coupled to a source of cooling fluid 42 that circulates through the housing 41 to maintain the motor 39 at an acceptable operating temperature. The end 91 of the screw conveyor 78 is in approximate alignment with the plane of the feed opening 87. The submerged burners 76 create turbulence in the melt pool 14 in the furnace melt chamber 82 to provide mixing of the batch material 33 with the melt pool 14 of glass in the furnace melt chamber 82 as it passes thorough the feed opening 87 into furnace melt chamber 82.

[00029] The present disclosure is directed to the concept of feeding glass batch material into a furnace at a location below the melt level to eliminate problems associated with the glass batch

“blanket” otherwise formed on the top surface of the melt. A screw conveyor may be used to feed the batch material into the melt pool in the furnace.

[00030] There thus has been disclosed an apparatus for feeding batch material into the furnace below the top surface of the melt pool that fully satisfies one or more of the objects and aims previously set forth. The disclosure has been presented in conjunction with several illustrative embodiments, and additional modifications and variations have been discussed. Other modifications and variations readily will suggest themselves to persons of ordinary skill in the art in view of the foregoing discussion. The disclosure is intended to embrace all such modifications and variations as fall within the spirit and broad scope of the appended claims.

Claims

1.

A glass furnace (10, 48, 55, 75) comprising:

5 a furnace melt chamber (12, 49, 56, 82) to contain a glass melt (14) having a top surface; and

a batch feeder (16, 36, 53, 78) to receive glass batch material and feed said material to the furnace melt chamber below the level of the glass melt top surface.

2.

10 The furnace set forth in claim 1 further comprising:

a dam wall (22, 43, 52) disposed with respect to the screw conveyor such that batch material from the screw conveyor must flow upward over the dam wall before entering the furnace melt chamber.

15

3.

The furnace set forth in claim 2 wherein a top (27, 44, 64) of the dam wall is below a melt level (28, 45, 88) in the furnace melt chamber.

4.

20 The furnace set forth in claim 2 further comprising:

a heater (20, 46, 57, 58) disposed to heat glass batch material prior to flow over the dam wall.

5.

The furnace set forth in claim 4 further comprising:

a well (23, 51) formed in the furnace melt chamber by the dam wall, wherein the heater is positioned in the well.

5

6.

The furnace set forth in claim 4 further comprising:

a heating element for the heater; and

a screw conveyor (24) for feeding batch material to an outlet (21) of the heater.

10

7.

The furnace set forth in claim 2 further comprising:

a heater (20, 46, 57) to introduce partially melted batch material into the furnace melt chamber; and

15 an outlet (21) for the heater positioned below the top of the dam wall.

8.

The furnace set forth in claim 1 further comprising:

a feed chamber (34, 51);

20 a hopper (30, 50) for supplying batch material to the feed chamber; and

a heater (46, 57, 58) positioned between the dam wall and a wall (31, 59) of the furnace melt chamber, whereby the batch feeder feeds batch material from the feed chamber to the heater, and whereby the heater partially melts batch material emerging from an outlet of the feed chamber.

9.

The furnace set forth in claim 8 wherein an outlet of the feed chamber is positioned within the furnace melt chamber.

5

10.

The furnace set forth in claim 8 further comprising:

a motor (39) having an output shaft (38) for driving the batch feeder in the form of a screw conveyor; and

10

a high thermal resistance joint (37) coupling the output shaft to the screw conveyor.

11.

The furnace set forth in claim 10 further comprising:

a motor housing (41) surrounding the motor; and,

15

a cooling fluid (42) filling the housing and surrounding the motor, the cooling fluid maintaining the motor at an acceptable temperature.

12.

The furnace set forth in claim 1 further comprising:

20

a plurality of feed chutes (16) to introduce batch material into the furnace melt chamber below the melt level;

a plurality of heaters (20) that receive batch material from the feed chutes to raise the temperature of the batch material before it is introduced into the glass melt; and

a dam wall (22) establishing a well (23) in the furnace melt chamber to separate the heaters from the glass melt in the furnace.

13.

5 The glass furnace set forth in claim 12 wherein the feed chutes include screw conveyors and heating elements.

14.

The glass furnace set forth in claim 1 further comprising:

10 the furnace melt chamber including a wall (31, 59);

a batch feed hopper (30, 50) adjacent to the wall of the furnace melt chamber to supply batch material under gravity;

the batch feeder being proximate a bottom (34, 61) of the hopper to receive the batch material;

15 a dam wall (43, 52) at the end of the batch feeder forming a well (23); and

a heater (46, 57, 58) between the dam wall and the wall of the furnace melt chamber to heat the batch material in the well before flowing over the dam wall.

15.

20 The glass furnace set forth claim 14 wherein the batch feeder is a screw conveyor oriented horizontally.

16.

The glass furnace set forth claim 14 wherein the batch feeder is a screw conveyor oriented vertically.

5

17.

The glass furnace set forth claim 16 further comprising:

a sloped bottom feed wall (62) connecting the batch feed hopper to the well, whereby the sloped bottom feed wall aids in maintaining an even flow of batch material to the vertically oriented screw conveyor.

10

18.

The glass furnace set forth in claim 1 further comprising:

the furnace melt chamber including a side wall (81) and a bottom wall (79) and containing a pool of glass melt (14) having a melt level (88);

15

a batch feed hopper (77) adjacent to the side wall of the furnace melt chamber to supply batch material under gravity to a bottom (84) of the hopper;

a feed opening (87) in the side wall of the furnace melt chamber for feeding batch material from the bottom of the hopper to the pool of glass melt below the melt level;

20

a batch feeder (78) proximate the bottom wall of the hopper to feed the batch material from the bottom of the hopper through the feed opening and into the furnace melt chamber; and

submerged heaters (76) proximate the bottom wall of the furnace melt chamber to heat the pool of glass melt in the furnace melt chamber, whereby the submerged heaters melt the batch material that is fed into the furnace melt chamber by the batch feeder.

19.

The glass furnace of claim 18 wherein the batch feeder is a screw conveyor oriented generally horizontally proximate the bottom of the hopper.

5

20.

The glass furnace of claim 19 wherein the feed opening in the side wall of the furnace defines a plane, and wherein the end of the screw conveyor is in approximate alignment with the plane of the feed opening.

10

15

20

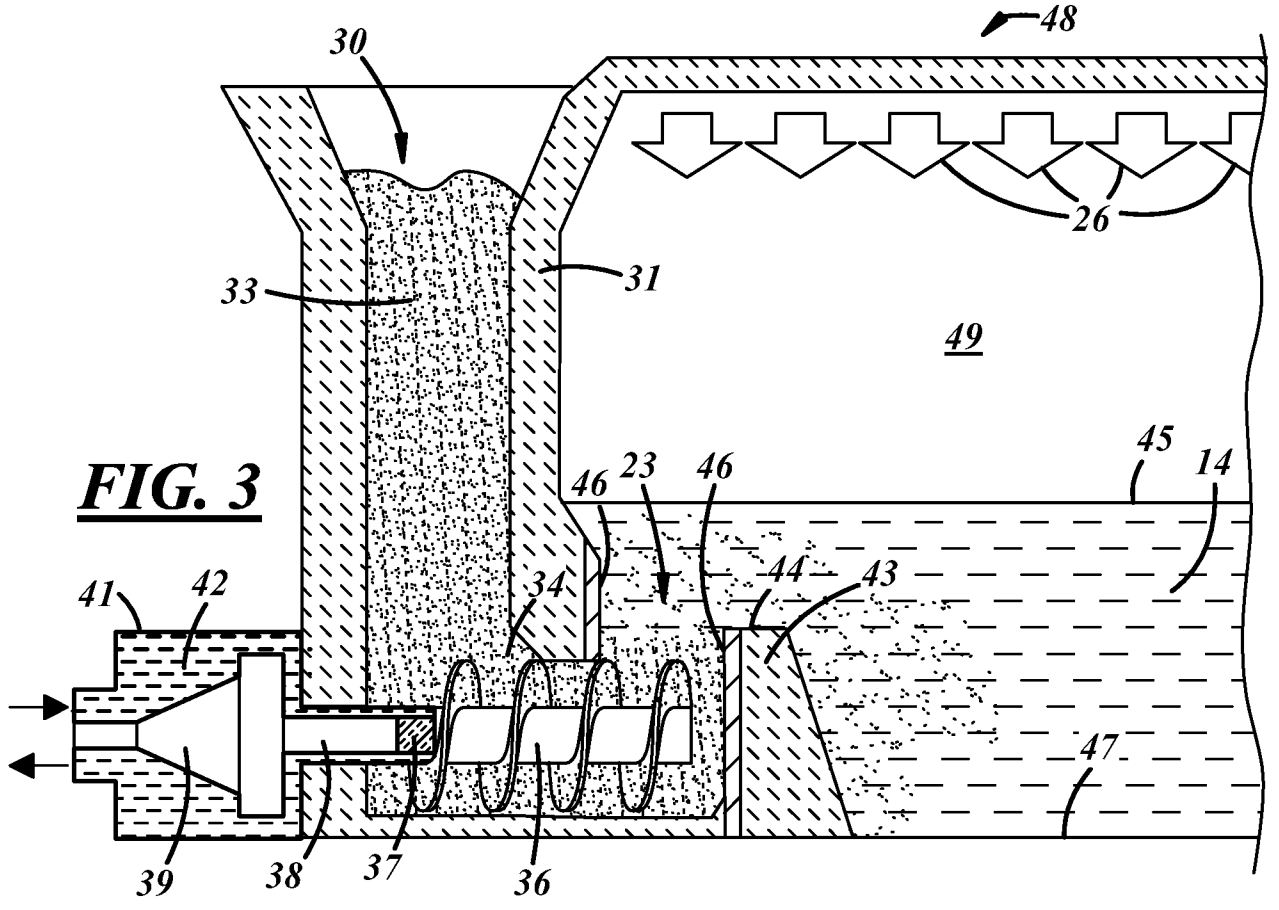
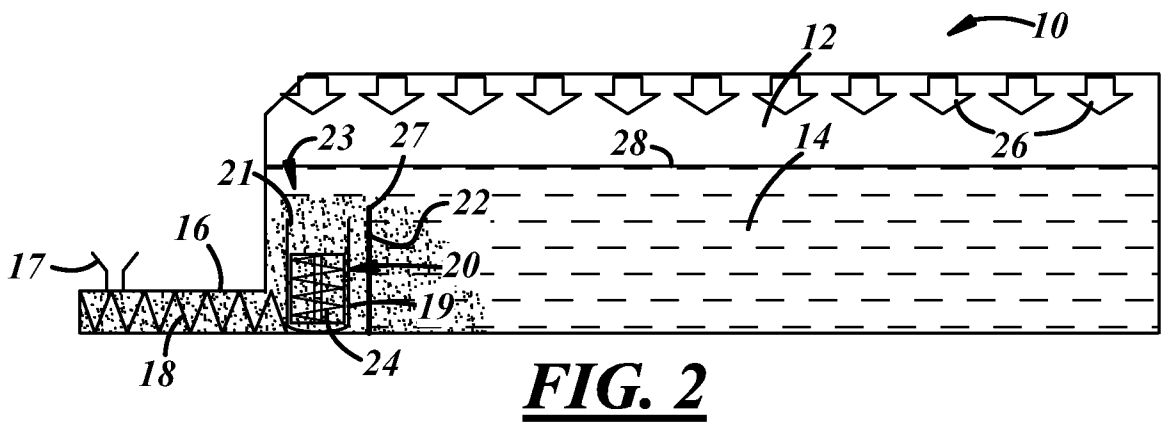
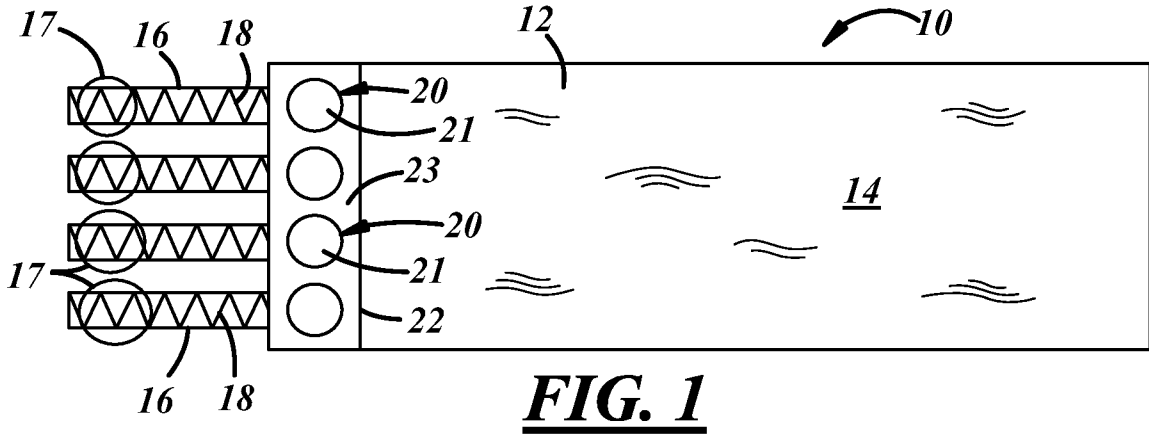

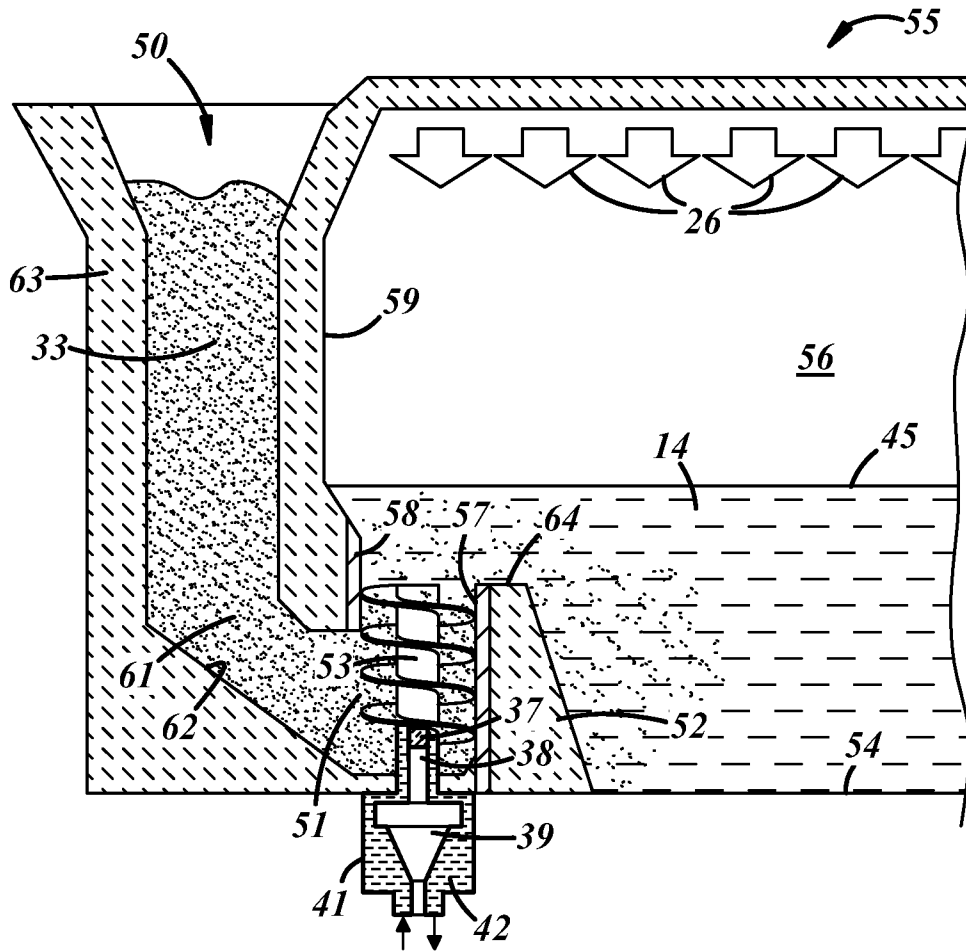

FIG. 4

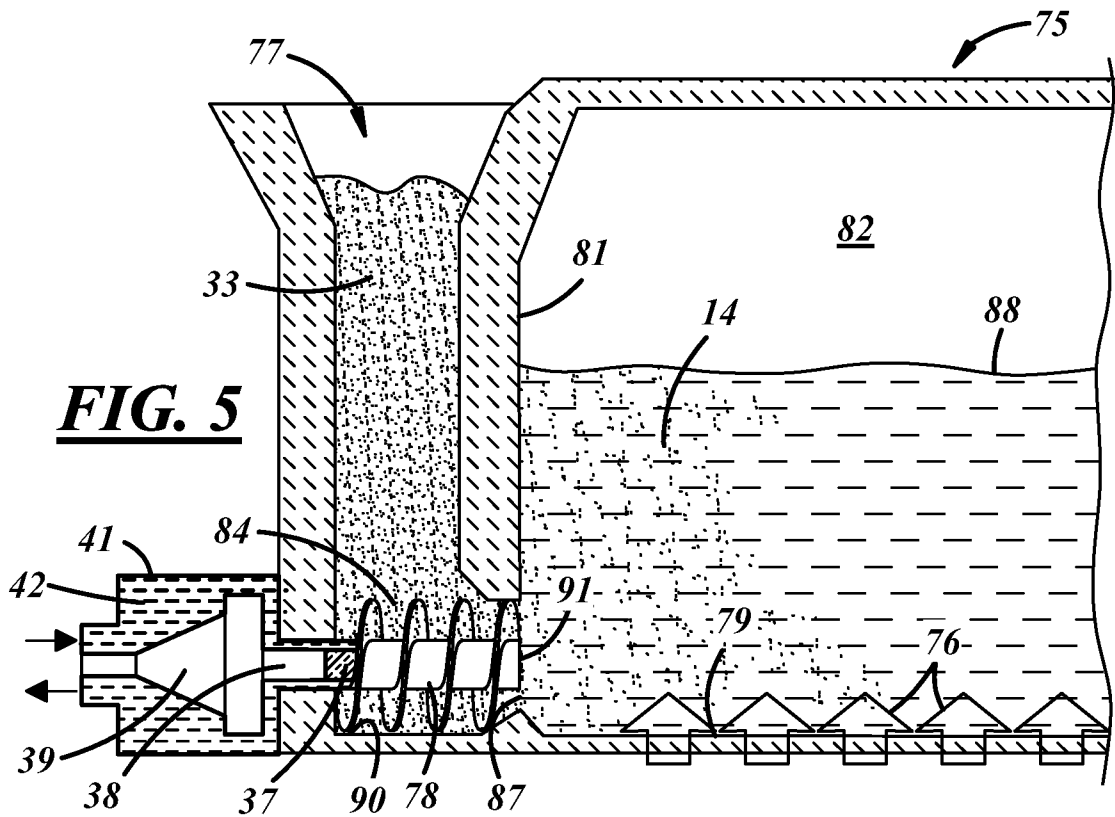

FIG. 5

INTERNATIONAL SEARCH REPORT

International application No
PCT/US2015/027440

A. CLASSIFICATION OF SUBJECT MATTER INV. C03B3/00 C03B5/20 ADD.				
According to International Patent Classification (IPC) or to both national classification and IPC				
B. FIELDS SEARCHED				
Minimum documentation searched (classification system followed by classification symbols) C03B				
Documentation searched other than minimum documentation to the extent that such documents are included in the fields searched				
Electronic data base consulted during the international search (name of data base and, where practicable, search terms used) EPO-Internal, WPI Data				
C. DOCUMENTS CONSIDERED TO BE RELEVANT				
Category*	Citation of document, with indication, where appropriate, of the relevant passages	Relevant to claim No.		
X	US 1 834 631 A (VERGIL MULHOLLAND) 1 December 1931 (1931-12-01)	1,10,11		
Y	items 1, 16, 17,28, 13; page 1, left-hand column, lines 1-10,36-44; figure 1 page 1, right-hand column, lines 80-84 page 2, left-hand column, lines 1-18 -----	2-9, 12-20		
X	US 2 354 807 A (FOX JOHN H ET AL) 1 August 1944 (1944-08-01)	1		
Y	items 180,188,185,172,70; page 2, left-hand column, lines 53-62,67-75; figure 2 page 2, right-hand column, lines 1-2 ----- -/--	9		
<table style="width: 100%; border: none;"> <tr> <td style="width: 50%; border: none;"><input checked="" type="checkbox"/> Further documents are listed in the continuation of Box C.</td> <td style="width: 50%; border: none;"><input checked="" type="checkbox"/> See patent family annex.</td> </tr> </table>			<input checked="" type="checkbox"/> Further documents are listed in the continuation of Box C.	<input checked="" type="checkbox"/> See patent family annex.
<input checked="" type="checkbox"/> Further documents are listed in the continuation of Box C.	<input checked="" type="checkbox"/> See patent family annex.			
* Special categories of cited documents :				
"A" document defining the general state of the art which is not considered to be of particular relevance	"T" later document published after the international filing date or priority date and not in conflict with the application but cited to understand the principle or theory underlying the invention			
"E" earlier application or patent but published on or after the international filing date	"X" document of particular relevance; the claimed invention cannot be considered novel or cannot be considered to involve an inventive step when the document is taken alone			
"L" document which may throw doubts on priority claim(s) or which is cited to establish the publication date of another citation or other special reason (as specified)	"Y" document of particular relevance; the claimed invention cannot be considered to involve an inventive step when the document is combined with one or more other such documents, such combination being obvious to a person skilled in the art			
"O" document referring to an oral disclosure, use, exhibition or other means	"&" document member of the same patent family			
"P" document published prior to the international filing date but later than the priority date claimed				
Date of the actual completion of the international search <div style="text-align: center; font-size: 1.2em;">29 July 2015</div>	Date of mailing of the international search report <div style="text-align: center; font-size: 1.2em;">07/08/2015</div>			
Name and mailing address of the ISA/ European Patent Office, P.B. 5818 Patentlaan 2 NL - 2280 HV Rijswijk Tel. (+31-70) 340-2040, Fax: (+31-70) 340-3016	Authorized officer <div style="text-align: center; font-size: 1.2em;">Gkerou, Elisavet</div>			

INTERNATIONAL SEARCH REPORT

International application No
PCT/US2015/027440

C(Continuation). DOCUMENTS CONSIDERED TO BE RELEVANT		
Category*	Citation of document, with indication, where appropriate, of the relevant passages	Relevant to claim No.
X	EP 0 135 446 A1 (SAINT GOBAIN VITRAGE [FR]) 27 March 1985 (1985-03-27) items 11,12,14-15,23-27,22,30,21,31; figure 2	1
Y	----- WO 2014/036979 A1 (VS CHEMICKO TECHNOLOGICKA V PRAZE [CZ]; GLASS SERVICE A S [CZ]; USTAV) 13 March 2014 (2014-03-13) items 2,7,10; page 10, lines 17-21,30,32-34; figures 5-6,11-19 page 11, lines 10-12,30-33 page 16, lines 29-34 page 17, lines 1-2,6,23-25 page 42, lines 6-18	2-8, 12-16,18
Y	----- US 2 512 761 A (PIERRE ARBEIT) 27 June 1950 (1950-06-27) items 15,15a-15c; figures 1-3,5	2-8, 12-16,18
Y	----- LU 77 649 A1 (BFG GLASSGROUP [FR]) 26 March 1979 (1979-03-26) items 17,18,41,42,44,45,71,72,75,76,83,84; figures 1-3	2-8, 12-16,18
Y	----- US 3 523 780 A (PLUMAT EMILE) 11 August 1970 (1970-08-11) figure 1	2-8, 12-16,18
Y	----- US 1 970 112 A (WADMAN HAROLD A) 14 August 1934 (1934-08-14) figure 1	17
Y	----- JP 2003 183031 A (NIPPON ELECTRIC GLASS CO) 3 July 2003 (2003-07-03) figure 1	19,20
A	----- JP 2010 222217 A (NIPPON ELECTRIC GLASS CO) 7 October 2010 (2010-10-07) figures 1-2	12

INTERNATIONAL SEARCH REPORT

Information on patent family members

International application No PCT/US2015/027440

Patent document cited in search report	Publication date	Publication date	Patent family member(s)	Publication date
US 1834631	A	01-12-1931	NONE	

US 2354807	A	01-08-1944	NONE	

EP 0135446	A1	27-03-1985	DE 3472097 D1	21-07-1988
			EP 0135446 A1	27-03-1985
			FR 2551746 A1	15-03-1985

WO 2014036979	A1	13-03-2014	NONE	

US 2512761	A	27-06-1950	BE 470589 A	29-07-2015
			FR 999843 A	05-02-1952
			GB 620355 A	23-03-1949
			US 2512761 A	27-06-1950

LU 77649	A1	26-03-1979	NONE	

US 3523780	A	11-08-1970	AT 280511 B	10-04-1970
			BE 684187 A	16-12-1966
			DE 1596455 A1	18-03-1971
			DK 113517 B	31-03-1969
			GB 1151086 A	07-05-1969
			LU 49817 A1	11-05-1967
			NO 117934 B	13-10-1969
			SE 331161 B	14-12-1970
			US 3523780 A	11-08-1970

US 1970112	A	14-08-1934	NONE	

JP 2003183031	A	03-07-2003	NONE	

JP 2010222217	A	07-10-2010	JP 5282619 B2	04-09-2013
			JP 2010222217 A	07-10-2010
