

O. B. AUSTIN.
Horse Hay-Rakes.

No. 148,401.

Patented March 10, 1874.

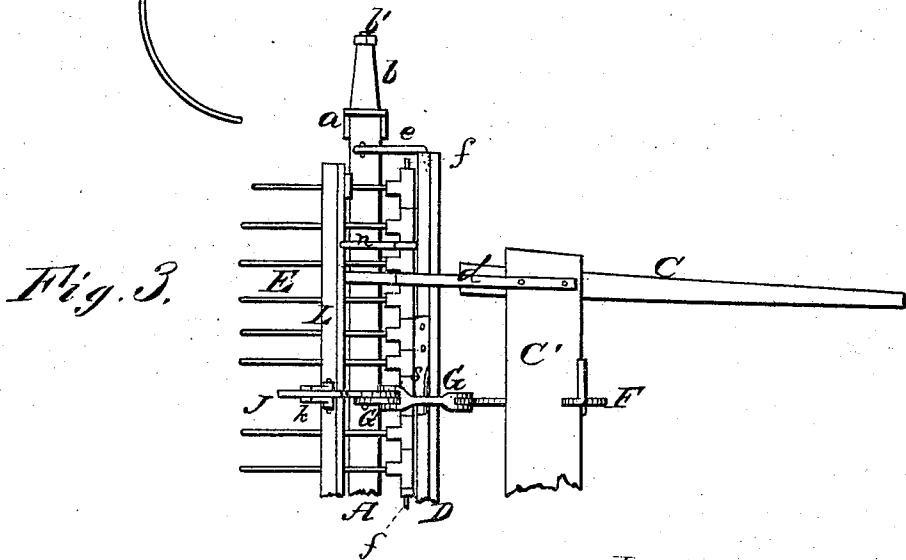
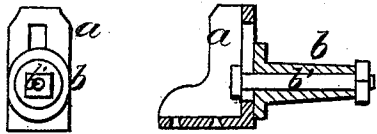
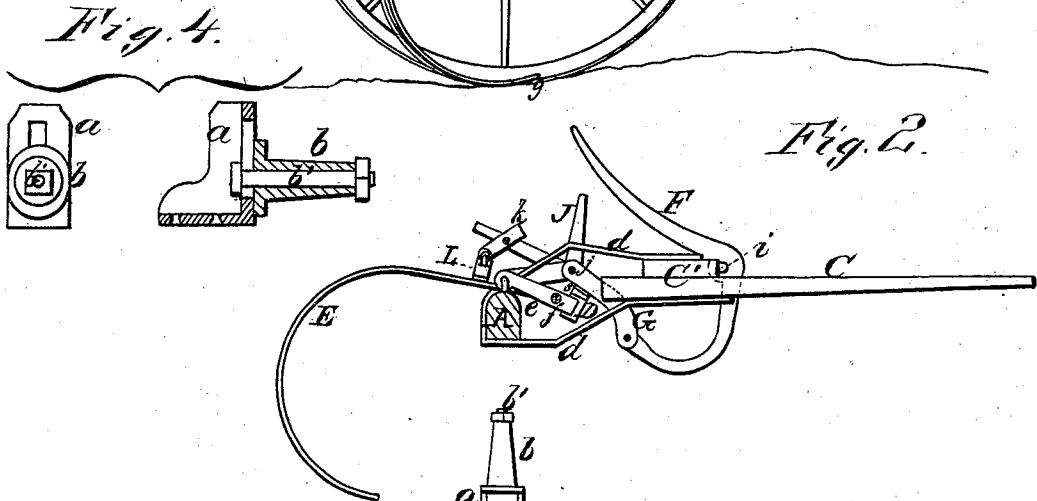
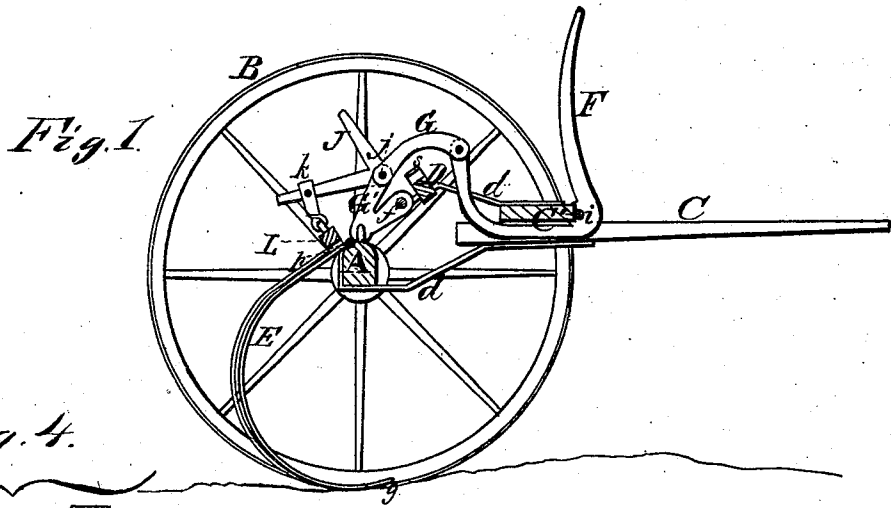

Witnesses:
E. A. Bates,
George C. Upham.

Inventor,
O. B. Austin,
Chipman & Foster & Co.,
Atty.

UNITED STATES PATENT OFFICE.

OEL B. AUSTIN, OF POTSDAM JUNCTION, NEW YORK.

IMPROVEMENT IN HORSE HAY-RAKES.

Specification forming part of Letters Patent No. **148,401**, dated March 10, 1874; application filed January 24, 1874.

To all whom it may concern:

Be it known that I, OEL B. AUSTIN, of Potsdam Junction, in the county of St. Lawrence and State of New York, have invented a new and valuable Improvement in Horse Hay-Rakes; and I do hereby declare that the following is a full, clear, and exact description of the construction and operation of the same, reference being had to the annexed drawings making a part of this specification, and to the letters and figures of reference marked thereon.

Figure 1 of the drawings is a representation of a sectional view of my horse hay-rake. Fig. 2 is a sectional detail of the same. Fig. 3 is a plan view, and Fig. 4 is a detail view, of the same.

This invention has relation to sulky hay-rakes; and it consists in the employment of locking-levers for raising and depressing the rake-teeth, where such levers are used in combination with a spring for locking them in position; also, in a novel mode of constructing and actuating the bar which holds the teeth down to their work.

The following is a description of my invention.

In the annexed drawings, A designates the axle of two transporting-wheels, B, on the ends of which axle are two vertically-slotted guide-blocks, *a*, to which the axle-skins *b* are rigidly secured by means of bolts and nuts *b'*, as shown by Fig. 4. This will allow the axle A to be adjusted higher or lower to adapt the teeth to rough or smooth surfaces. C C are the thills, which are secured to the axle A by means of straps *d*, which extend downward and backward beneath the axle, then upward and forward to the thills again. Each one of these looped straps may be made of cast or wrought iron, sufficient space being left between its upper and lower portions for the play of the rake-head. D designates a bar, which passes through the looped attachments *d*, and is secured to arms *e*, which are connected by pivots to the axle A. The bar D is in front of and parallel with the axle A, and constitutes, with its arms *e*, a vertically-vibrating frame, which affords end bearings for the rod *f*, on which the rake-teeth E articulate. The front ends of the rake-teeth should extend far enough in advance of the axle A to be balanced, or nearly balanced, thereon, thus relieving the attendant from expending much labor in raising the teeth for discharging the gathered loads. By thus ad-

vancing the pivoted ends of the rake-teeth, their raking ends can be arranged in line with the lowest points or treads of the transporting-wheels B, thus allowing these raking ends to rise and descend with the wheels without digging into the ground. The teeth E, which are at the ends of the rake-rod *f*, are pressed somewhat farther forward than the other teeth by means of blocks *p p*, as shown at *g*, for the purpose of gathering in the hay and preventing it from spreading at the sides of the machine. F designates a hand-lever, which is pivoted at *i* to the cross-bar C' of thills C, and which is curved backward and upward from this pivot. G designates an arched link, which is pivoted at one end to the upturned end of lever F, and at the other end to the upper end of a V-shaped lever, G'. This lever G' is pivoted by its acute angle to the axle A, and by its front lower end to the rod *f*, on which the rake-teeth articulate. The arched link G extends over a spring, *s*, which is secured on the bar D, which spring is depressed during the act of adjusting the rake-teeth into working position, and by its recoil it throws up the link G and locks the joints. J designates an angular hand-lever, which is pivoted to the V-shaped lever G' at *j*, and connected by a pivot to a short pivoted arm, *k*, on the pressure-bar L. This bar L is parallel to the axle A, and it is arranged over the rake-teeth in rear of this axle, and connected by means of articulating arms *n* to the rod *f*. By means of the hand-lever J, the attendant can hold the rake-teeth down to their work, and by means of blocks *p p* on the extremities of the bar L the end teeth are kept in the advanced position above explained.

What I claim as new, and desire to secure by Letters Patent, is—

1. The curved hand-lever F, arched link G, and V-shaped lever G', combined with spring *s*, and arranged as and for the purposes described.

2. The pressure-bar L and its end blocks *p*, in combination with teeth E, lever J, and arm *k*, as and for the purposes set forth.

In testimony that I claim the above I have hereunto subscribed my name in the presence of two witnesses.

OEL B. AUSTIN.

Witnesses:

HORACE E. LOVE,
HENRY W. AUSTIN.