

W. W. WALLER.

AIR COOLING MACHINE.

APPLICATION FILED SEPT. 3, 1910.

Patented July 11, 1911.

2 SHEETS—SHEET 1.

997,872.

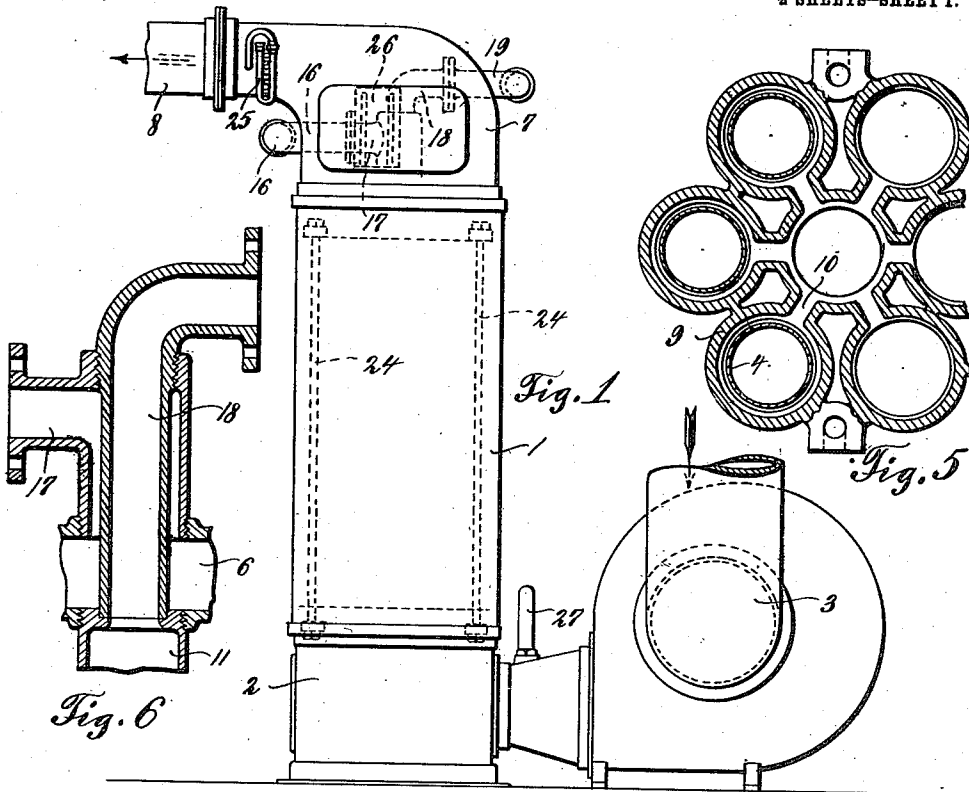

Fig. 6

Fig. 1

Fig. 5

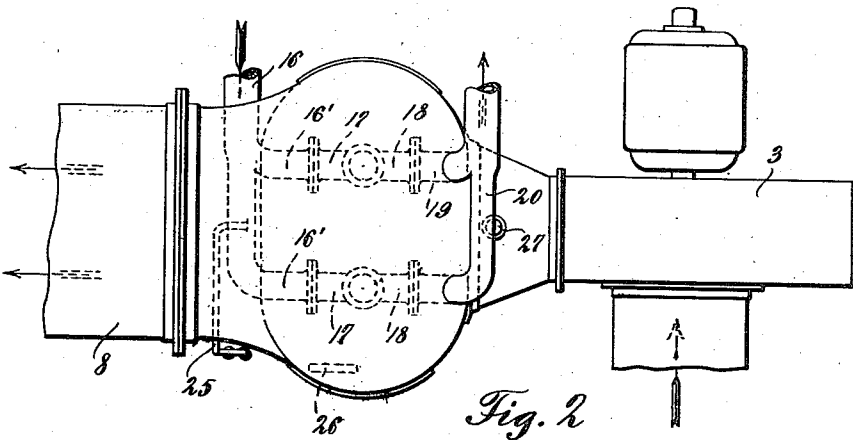

Fig. 2

Witnesses

E. Larson
Chas. Colburn

Inventor

W. W. Waller

384

Declaré Robt
Attorneys

W. W. WALLER.
 AIR COOLING MACHINE.
 APPLICATION FILED SEPT. 3, 1910.

997,872.

Patented July 11, 1911.

2 SHEETS-SHEET 2.

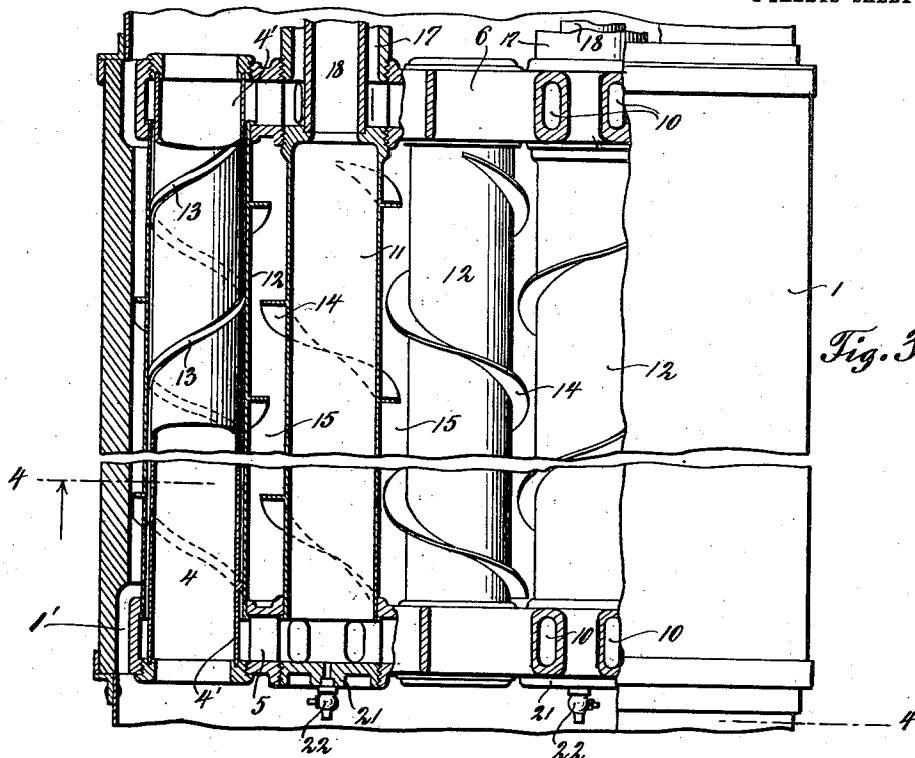

Fig. 3

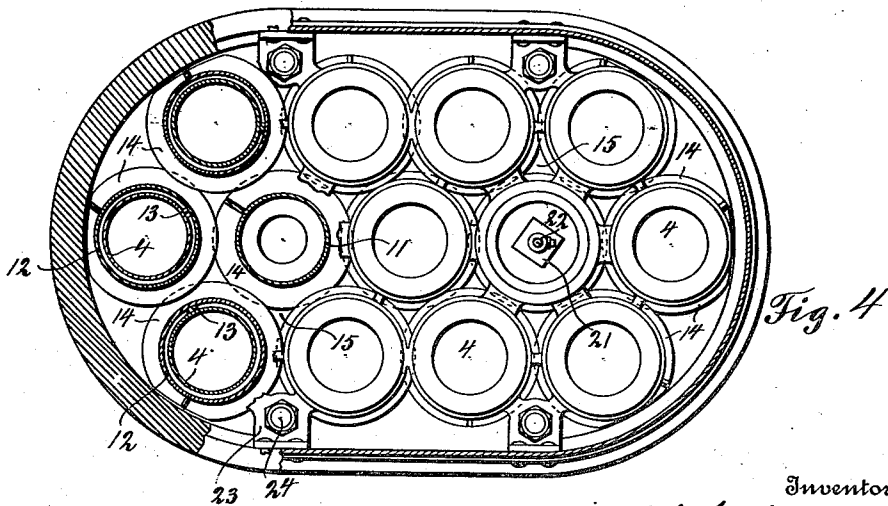

Fig. 4

Witnesses

E. Larson
Chas. Colman

Inventor

W. W. Waller

By

Delevant & Co
 Attorneys

UNITED STATES PATENT OFFICE.

WILLIAM W. WALLER, OF WASHINGTON, DISTRICT OF COLUMBIA, ASSIGNOR OF ONE-HALF TO HARVEY EARLTON HANES, OF HERNDON, VIRGINIA.

AIR-COOLING MACHINE.

997,872.

Specification of Letters Patent.

Patented July 11, 1911.

Application filed September 3, 1910. Serial No. 580,460.

To all whom it may concern:

Be it known that I, WILLIAM W. WALLER, a citizen of the United States, residing at Washington, in the District of Columbia, have invented certain new and useful Improvements in Air-Cooling Machines, of which the following is a specification.

The present invention, broadly speaking, comprises a machine particularly designed for use in connection with a ventilating system, and by which the temperature and hygroscopic conditions of the air may be controlled to any reasonable degree in closed compartments such as magazines, store rooms, living spaces or cargo spaces on various types of vessels: the invention is also useful in public buildings of all kinds, hospitals, manufacturing plants, etc., as well as for use as a water heater, cooler and condenser, and for aerating purposes generally.

As is well known, the cooling of magazines of war ships, especially those containing smokeless powder, has been a serious problem in recent years, and means heretofore devised for the purpose have been defective or impractical for one reason or another. The present machine is adapted to cool magazines, and to control hygroscopic conditions, whereby liability of explosion due to the excessive high temperature in the magazine is practically avoided, and deterioration of powder or other explosives due to variation in temperature in the compartment in which they are stored is eliminated.

A machine constructed in accordance with this invention has a large number of different uses and applications more or less remotely related to those hereinbefore set forth.

Referring to the accompanying drawings, Figure 1 is a view in elevation showing an air cooling machine embodying the principal features of this invention; Fig. 2 is a top plan view of the same; Fig. 3 is a view of the body or casing of the machine, partly broken away to show the internal arrangement of the cooling means certain portions of the latter being illustrated in section; Fig. 4 is a sectional view taken about on the line 4-4 of Fig. 3; Fig. 5 is a partial sectional view of one of the headers with which the atmospheric air pipes are connected; Fig. 6 is a fragmentary view showing the coupling connecting the refrigerant pipes

and the upper header with the refrigerant supply and outflow pipes.

Specifically describing the invention and referring to the drawings, 1 denotes the body or casing of the machine, at the lower end of which is connected an air supply chamber 2, the latter in turn being connected with a blower or fan 3 of any suitable type, which fan supplies atmospheric air under pressure to the chamber 2, said air passing upwardly from said chamber through a plurality of atmospheric air pipes 4. The pipes 4 will be employed in any suitable number, depending upon the desired capacity of the machine, and said pipes are connected at their lower ends with a header 5, and at their upper ends with a second header 6, the pipes 4 extending through the hollow portions of said headers as shown at 4'. It will thus be apparent that the atmospheric air will enter an air chamber 7 above the casing 1 after it has passed through the pipes 4, and while the air is passing through the pipes 4 it is cooled by means comprising the essential feature of the present invention. When cooled, the air passes through the chamber 7 and through a pipe 8 to the magazine or other compartment to be supplied with the cooling medium.

The headers 5 and 6 are of skeleton structure, so to speak, embodying a plurality of tubular hollow portions 9 connected with one another by suitable passages 10 shown most clearly in Fig. 5 of the drawings. The various tubular or hollow portions 9 of one header are connected with the corresponding portions of the other header by the pipes 4 hereinbefore described, and by other pipes 11, which for the purposes of this description will be called refrigerant return pipes. The pipes 11 are preferably two in number for a machine of the capacity illustrated in the drawing, and said pipes communicate at their lower ends with the interior of the lower header 5.

Surrounding each of the atmospheric air pipes 4 is a shell or pipe 12 closely spaced with respect to the pipes 4 adjacent. Interposed between the shells 12 and pipes 4 are spiral fins 13, necessitating that the refrigerating medium introduced into the space between each pipe 4 and its shell 12 shall take a tortuous passage until it reaches the space within the lower header 5. The refrigerant return pipes 11 and also the shells

12 are surrounded by fins 14 similar to the fins 13, but of larger size.

In the actual operation of the invention, the atmospheric air is forced into the chamber 2 by the fan 3, and said air passes constantly upward through the pipes 4 and also through the spaces between the shells 12 and the pipes 11, said spaces being designated at 15. The atmospheric air is cooled as it passes upwardly in the casing 1 in the manner above described by using a refrigerating medium, which is supplied from a suitable ice machine, not shown, the refrigerating medium entering the present machine through an inflow pipe 16, having lateral branches 16' leading to L-couplings 17, the lower ends of which are connected, and in communication with the upper header 6. The refrigerating medium thus passes through the couplings 17 into the upper header 6, said upper header being in communication with the spaces between the pipes 4 and the shells 12. The refrigerating medium thus passes downwardly through the spaces between the pipes 4 and surrounding shells 12, the atmospheric air passing upwardly through the pipes 4 being thus cooled, and that portion of the atmospheric air passing upwardly through the spaces 15 being cooled by contact with the outer sides of the shells 12. When the refrigerating medium reaches the lower ends of the shells 12, it enters the lower header 5 and the only outlets from the header 5 for said refrigerating medium, are the refrigerant return pipes 11 above described. The upper ends of said pipes 11 communicate with the lower ends of coupling connections 18, the latter passing through the couplings 17 as shown in Fig. 6. The coupling connections 18 are in turn attached to branch outflow pipes 19 which connect with the main refrigerant outflow pipes 20, the latter returning the refrigerating medium to the refrigerating machine after said medium has been passed through the cooling machine of the present invention.

Suitable plugs 21 are used to close the portions of the lower header 5 immediately below the refrigerant return pipes 11, and said plugs 21 may have suitable draw-off cocks 22 to facilitate drawing off any water of condensation in the header 5.

Broadly describing the general operation of the machine, it will be observed that as the atmospheric air flows constantly upwardly through certain pipes in the casing 1, the refrigerating medium is flowing downwardly around said atmospheric air pipes. The atmospheric air is cooled not only in the atmospheric air pipes but in the spaces between said pipes and after the refrigerating medium has passed downwardly to cool the pipes 4 it is returned to the refrigerating machine by flowing upwardly in the casing

1 through certain pipes which perform a cooling function with respect to the atmospheric air.

The headers 5 and 6 are preferably supported in the casing 1 by suitable brackets 23 and cooperating vertical rods 24.

A pressure gage 25, a hygrometer 26, and a thermometer 27 will be attached to the machine.

A special feature of advantage of this invention is the compact structure of the machine above described whereby space may be economized in using the machine, a factor of especial importance, having in view the nature of the invention.

It will be observed that the lower end of the casing 1 is formed with an annular recess 1' increasing the area for the flow of air through and around the lower header. When the air strikes the upper end of the recess 1', which end is curved inwardly, the air is deflected inwardly into contact with the cooling pipes or shells.

The expressions "refrigerant" and "atmospheric air" pipes as used herein are in the sense of distinguishing parts of applicant's invention, and are relative terms, it being understood that under certain conditions of use of applicant's invention, for instance, as a heater, warm air would be supplied instead of a refrigerating medium, and cold air may be passed through the atmospheric air pipes.

I do not desire to be restricted to the exact construction of the invention as illustrated in the drawings, for the same will be modified according to the broad spirit of the invention defined by the claims hereto appended.

Having thus described the invention, what is claimed as new is:

1. In a machine of the type described, the combination of a plurality of atmospheric air pipes, means for passing air through said pipes, shells surrounding the atmospheric air pipes and in spaced relation thereto, means for passing a refrigerating medium through the spaces between the shells and the atmospheric air pipes, and refrigerant return pipes in spaced relation to the atmospheric air pipes, and connected with the spaces between the shells and atmospheric air pipes.

2. In a machine of the class described, the combination of spaced hollow headers, atmospheric air pipes connected with said headers and arranged in spaced relation to one another, means for passing air through said atmospheric air pipes and through the spaces between the same, shells surrounding the atmospheric air pipes and communicating at end portions thereof with one of the headers, means for forcing a refrigerating medium between the atmospheric air pipes and the shells aforesaid into the header communicating with the shells, and refrigerant

return pipes connected with said header and arranged in spaces between the atmospheric air pipes.

3. In a machine of the class described, the combination of spaced hollow headers, atmospheric air pipes connected with said headers and passing through the hollow portions thereof, shells surrounding the atmospheric air pipes in spaced relation thereto and communicating at opposite ends with the hollow portions of the headers, means for passing atmospheric air through the atmospheric air pipes, and means for passing a refrigerating medium through the spaces between the atmospheric air pipes and their surrounding shells.

4. In a machine of the class described, the combination of spaced hollow headers, atmospheric air pipes connected with said headers and passing through the hollow portions thereof, shells surrounding the atmospheric air pipes in spaced relation thereto and communicating at opposite ends with the hollow portions of the headers, means for passing atmospheric air through the atmospheric air pipes, means for passing a refrigerating medium through the spaces between the atmospheric air pipes and their surrounding shells, and means connected with one of the headers to return the refrigerating medium to the source of supply.

5. In a machine of the class described, the combination of spaced hollow headers, atmospheric air pipes connected with said headers and passing through the hollow portions thereof, shells surrounding the atmospheric air pipes in spaced relation thereto and communicating at opposite ends with the hollow portions of the headers, means for passing atmospheric air through the atmospheric air pipes, means for passing a refrigerating medium through the spaces between the atmospheric air pipes and their surrounding shells, and pipes arranged between the atmospheric air pipes and connected with one of the headers to carry off the refrigerating medium from the machine after it has passed through the spaces surrounding the atmospheric air pipes.

6. In a machine of the class described, the combination of spaced headers comprising a plurality of hollow portions in communication with one another, atmospheric air pipes connected with the corresponding hollow portions of the headers but passing therethrough, shells surrounding said atmospheric air pipes and connected at opposite ends with the headers in communication with the hollow portions of the latter, means for passing a refrigerating medium into one of the headers through the spaces surrounding the atmospheric air pipes and into the other header, and a return pipe connected with the last mentioned header and arranged between the atmospheric air pipes to carry

the refrigerating medium off from the machine.

7. In a machine of the class described, the combination of spaced headers comprising a plurality of hollow portions in communication with one another, atmospheric air pipes connected with the corresponding hollow portions of the headers but passing therethrough, shells surrounding said atmospheric air pipes and connected at opposite ends with the headers in communication with the hollow portions of the latter, means for passing a refrigerating medium into one of the headers through the spaces surrounding the atmospheric air pipes and into the other header, and means connected with the last named header for carrying the refrigerating medium off from the machine.

8. In a machine of the class described, the combination of spaced headers comprising a plurality of hollow portions in communication with one another, atmospheric air pipes connected with the corresponding hollow portions of the headers but passing therethrough, shells surrounding said atmospheric air pipes and connected at opposite ends with the headers in communication with the hollow portions of the latter, means for passing a refrigerating medium into one of the headers through the spaces surrounding the atmospheric air pipes and into the other header, and means connected with the last mentioned header and passing through the space between certain atmospheric air pipes and through the first mentioned header to carry off the refrigerating medium from the machine.

9. In a machine of the class described, the combination of spaced headers comprising a plurality of hollow portions in communication with one another, atmospheric air pipes connected with the corresponding hollow portions of the headers but passing therethrough, shells surrounding said atmospheric air pipes and connected at opposite ends with the headers in communication with the hollow portions of the latter, means for passing a refrigerating medium into one of the headers through the spaces surrounding the atmospheric air pipes and into the other header, and means connected with the last mentioned header and passing through the space between certain atmospheric air pipes and through the first mentioned header to carry off the refrigerating medium from the machine, the atmospheric air supply means being connected with the spaces between the shells surrounding the atmospheric air pipes.

10. In a machine of the class described, the combination of spaced hollow headers, a plurality of atmospheric air pipes arranged in spaced relation to one another and connected with said headers, shells surrounding the atmospheric air pipes and in

spaced relation thereto, means for supplying a refrigerating medium to one of the headers and to the space surrounding the atmospheric air pipes, refrigerant return pipes connected with the other header to carry the refrigerating medium off from the spaces surrounding the atmospheric air pipes, fins applied to the external surface of the refrigerant pipes, the latter being arranged in a space surrounded by atmospheric air pipes, and means for passing atmospheric air through the atmospheric air pipes and through the spaces between the shells aforesaid and between the shells and adjacent refrigerant return pipes.

11. In a machine of the class described, the combination of spaced hollow headers, atmospheric air pipes connected therewith and passing through the hollow portions thereof, shells surrounding said atmospheric air pipes in spaced relation thereto and communicating with the hollow portions of the headers, refrigerant return pipes communicating with one of the headers, and coupling connections connected with said refrigerant return pipes and passing through the other header, and refrigerating medium supply couplings attached to the first mentioned header through which the coupling connections aforesaid pass.

12. In a machine of the class described, the combination of spaced hollow headers, atmospheric air pipes connected therewith and passing through the hollow portions thereof, shells surrounding said atmospheric

air pipes in spaced relation thereto and communicating with the hollow portions of the headers, refrigerant return pipes communicating with one of the headers, coupling connections connected with said refrigerant return pipes and passing through the other header, refrigerating medium supply couplings attached to the first mentioned header through which the coupling connections aforesaid pass, spiral fins interposed between the shells and atmospheric air pipes, and other fins externally arranged upon the shells and the refrigerant return pipes.

13. In a machine of the class described, the combination of a casing, spaced hollow headers therein, atmospheric air pipes in said casing, an air supply chamber at one end of the casing, means for forcing air from said supply chamber through said atmospheric air pipes, a second chamber at the opposite end of the casing, an outflow pipe connected with said second air chamber, and means for conducting a refrigerating medium through the second air chamber, circulating said air around the atmospheric air pipes and discharging said refrigerating medium from the second air chamber by return movement after circulation around the atmospheric air pipes.

In testimony whereof I affix my signature in presence of two witnesses.

WILLIAM W. WALLER.

Witnesses:

FRANCIS S. MAGUIRE,
J. F. ROBB.