

Sept. 8, 1953

R. S. ROSS ET AL

2,651,709

SELF-ILLUMINATING COSMETIC APPLICATOR

Filed Sept. 12, 1950

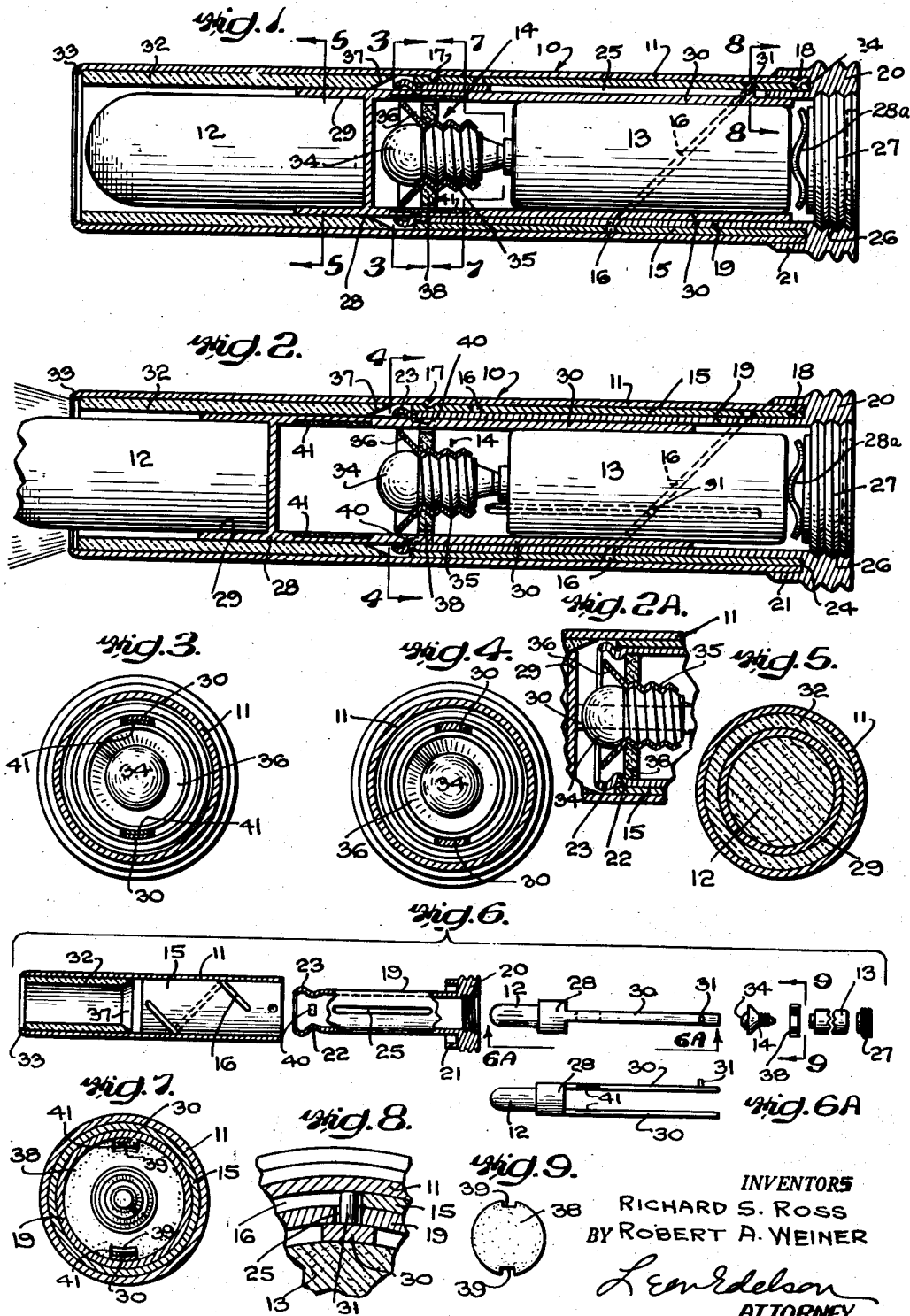

INVENTORS
RICHARD S. ROSS
BY ROBERT A. WEINER

Leondelson
ATTORNEY

UNITED STATES PATENT OFFICE

2,651,709

SELF-ILLUMINATING COSMETIC APPLICATOR

Richard S. Ross, Elkins Park, and Robert A. Weiner, Philadelphia, Pa.

Application September 12, 1950, Serial No. 184,444

2 Claims. (Cl. 240—6.45)

1

This invention relates generally to cosmetic applicators and more particularly to an improved construction of applicator for lipsticks wherein is incorporated a light source operative to directly illuminate the lips of the person using the applicator.

It is frequently the case that one who desires to apply a cosmetic, such as lipstick, to the lips is without adequate illumination to properly perform the task and it is among the principal objects of the present invention to provide a lipstick applicator in which is self-contained a flashlight arranged to project light axially forward of the lipstick end of the applicator so that during the application of the lipstick the lips will be fully illuminated.

A further and important object of the invention is to provide a lipstick applicator which is externally of more or less conventional appearance and which includes as a self-contained element thereof a flashlight which is automatically operative to project light from the lipstick end of the applicator when the latter is actuated to axially project the lipstick into its applying position.

Still another object of the invention is to provide a lipstick applicator with a built-in switch-actuated electric flashlight which is so organized and operative as to project a beam of light forwardly of and in embracing relation with respect to the lipstick of the applicator, the assembly being adapted for use as a miniature flashlight when emergency requires its use as such.

Other objects and advantages of the invention, such as relate to general and specific details of construction and to effecting a construction which is economical to manufacture, simple to use and efficient in operation, will appear more fully hereinafter, it being understood that the present invention consists substantially in the combination, construction, location and relative arrangement of parts, all as will appear from the detailed description which follows, as shown in the accompanying drawings and as finally pointed out in the appended claims.

In the accompanying drawings, which are illustrative of a preferred embodiment of the invention:

Figure 1 is a longitudinal cross-sectional view of a lipstick applicator having a switch-actuated flashlight incorporated therein in accordance with the principles of the present invention;

Figure 2 is a view similar to Figure 1, but showing the lipstick projected into applying

2

position and the flashlight operative to illuminate the region immediately in advance of the lipstick;

Figure 2A is a transverse sectional view of the light source portion of the unit as it appears when rotated ninety degrees from its position shown in Figure 1;

Figure 3 is a transverse sectional view as taken along the line 3—3 of Figure 1;

Figure 4 is a transverse sectional view as taken along the line 4—4 of Figure 2;

Figure 5 is a transverse sectional view as taken along the line 5—5 of Figure 1;

Figure 6 is an exploded view of the several component parts of the lipstick applicator, certain of which parts are shown in section;

Figure 6A is a side elevational view of the axially shiftable lipstick carriage as it appears when viewed from the line 6A—6A of Figure 6;

Figure 7 is a transverse sectional view as taken along the line 7—7 of Figure 1;

Figure 8 is an enlarged sectional view of a constructional detail as taken along the line 8—8 of Figure 1; and

Figure 9 is an elevational view of the supporting disk for the lamp socket as it appears when viewed from the line 9—9 of Figure 6.

Referring now more particularly to the drawings, it will be observed that the lipstick applicator unit of the present invention, designated generally by the reference numeral 10, comprises an outer cylindrical casing 11 of a length sufficient to accommodate therein a replaceable lipstick element 12 of any conventional composition, a replaceable dry cell battery 13 also of any conventional construction and a flashlight bulb and socket assembly 14 disposed intermediate the axially spaced lipstick element and dry cell battery.

Nonrotatably fitted within the rear portion of the outer casing 11 is an inner shell or sleeve 15, the cylindrical wall of which is spirally slotted, as at 16, throughout a substantial portion of its length, the opposite ends of the spiral slot terminating short of the corresponding ends of the sleeve 15. Preferably, the sleeve 15, which is snugly fitted within the outer casing 11, is secured against rotation and axial movement relatively to said casing by complementally indenting the casing and sleeve, as at 17 and 18. However, any other suitable means may be employed for fixedly securing the spirally slotted sleeve 15 within the outer casing 11 and, if desired, the slotted sleeve may be formed as an integral part of the external casing.

3

Rotatably fitted within the spirally slotted sleeve 15 is an inner cylindrical shell 19, the rear end of which is provided with a thickened wall portion 20 having an outer flange 21 in spaced, concentric relation with respect to the main body portion of the shell 19. As most clearly appears in Figures 1 and 2, the spacing between the shell 19 and its concentric flange 21 is just sufficient to snugly accommodate therebetween the rear end portions of the interlocked outer casing 11 and the spirally slotted sleeve 15. The forward end of the inner cylindrical shell 19 is shaped to provide an internal annular constriction 22 and a closely adjoining external annular bead 23, which latter engages the forward end of the spirally slotted sleeve 15 and so prevents rearward axial displacement of the inner shell 19 relatively to the outer casing 11. Axial displacement of the inner shell 19 in the opposite direction relatively to the outer casing is, of course, prevented by engagement of the thickened portion 20 of the shell with the rear end of the outer casing, as at 24. Thus, the inner shell 19, while restrained against axial movement in either direction relatively to the outer casing 11 and its fixedly associated spirally slotted sleeve 15, is, nevertheless, free to rotate within the casing and slotted sleeve assembly.

The inner shell 19 is provided with a longitudinally extending slot 25 of a length substantially coextensive with the overall axial length of the spiral slot 16 in the sleeve 15. The thickened rear end 20 of the inner shell 19 is internally threaded, as at 26, to removably receive a plug-type closure member 27, which serves as the rear abutment for the conventional contact spring 28a engageable with the base of the flashlight battery 13. It will be understood, of course, that upon removal of the closure member 27 the battery and the flashlight bulb and socket assembly 14 may be readily removed from the rear end of the unit for such replacement and servicing as may be required.

The consumable lipstick element 12 is removably fitted in and carried by a carrier 28 of the form best shown in Figures 6 and 6A, this carrier having a forwardly presenting cylindrical socket 29 for the lipstick and a pair of diametrically opposed, rearwardly extending bars 30—30 respectively disposed in sliding contact with the internal wall surface of the shell 19. One of these bars 30—30 is provided adjacent its rear extremity with a laterally projecting pin 31, which projects through the elongated slot 25 of the shell 19 and into the spiral slot 16 of the sleeve 15 (see Figures 1 and 8).

It will be apparent that upon rotation of the inner shell 19 relatively to the external casing 11 and the spirally slotted sleeve 15, the slot 16 of the latter will function as a cam upon the pin 31, which is restrained against all but rectilinear movement by the linear slot 25 in the inner shell 19, to propel the lipstick carrier axially of the casing 11 in one direction or the other depending upon the direction of rotation of the shell 19 relatively to the casing 11. Thus, by holding the casing 11 in one hand and rotating the terminal end 20 of the shell 19 by the other hand, the lipstick carrier 28 may be projected from its retracted position shown in Figure 1 into its fully extended position shown in Figure 2, the carrier being withdrawn into its retracted position by merely reversely rotating the terminal end 20 of the shell.

Non-rotatably fitted in the forward portion of the outer casing 11 in embracing relation with

4

respect to the axially movable lipstick carrier 28 is a cylinder 32 of suitable light-transmitting plastic material, such as "Lucite," "Polystyrene" or "Lumarith," this material having the peculiar property of transmitting light linearly there-through. Thus, when light from a suitable source is directed against the rear end of the light transmitting barrel 32, it emanates from the frontal end thereof in the form of a concentrated beam extending forwardly of and surrounding the lipstick element 12. Preferably, the frontal end of the casing 11 is slightly intumed, as at 33, to prevent axial displacement of the light transmitting barrel 32 from the casing.

The source of light for transmission forwardly through the plastic barrel 32 is, of course, the flashlight bulb 34 which is supported in a lamp socket 35. This socket 35 is preferably provided at its forward end with an integrally formed reflector portion 36 designed to direct the light rays against the rear end of the light transmitting plastic barrel 32. Preferably, this rear end of the barrel 32 is beveled, as at 37, to provide a maximum area for reception of light to be transmitted linearly through the barrel.

The lamp socket 35 is threadedly seated in a supporting disk 38 of suitable insulating material, this disk being of a diameter to snugly fit within the inner shell 19 with its marginal edge bearing against the internal annular constriction 22 formed in said shell. The lamp-socket supporting disk 38 is provided with a pair of diametrically opposed notches 39—39 through which respectively project the rearwardly extending bars 30—30 of the lipstick carrier, the disk 38 being thus nonrotatably held between the said bars 30—30. It will be noted, also, that these bars are respectively fitted in a pair of diametrically opposed slots or notches 40—40 formed in the annular constriction 22 of the inner shell 19, in consequence of which the lipstick carrier is free to shift axially of the inner shell 19, while at the same time it is constrained against rotation relatively therethrough.

The bars 30—30 of the lipstick carrier are respectively in wiping contact with the marginal edge of the reflector portion 36 of the lamp socket 35, so that when the lipstick carrier is projected into its forward position, as shown in Figure 2, the electrical circuit from the dry cell battery 13 to the lamp bulb 34 is automatically completed. In order to interrupt this circuit when the lipstick carrier is drawn into its retracted position shown in Figure 1, the bars 30—30 of the carrier are respectively provided with insulating inserts 41—41 adapted to be engaged by the reflector portion 36 of the lamp socket. These inserts 41—41 are preferably formed flush with the inner surfaces of the bars 30—30 so as not to interfere with free sliding movement of the latter relatively to the lamp socket contacting reflector. Of course, any other suitable provision may be made for interrupting the current supply to the lamp automatically upon retraction of the lipstick carrier, or, if desired, a manually operated switch may be provided for controlling operation of the lamp independently of any actuation of the lipstick carrier.

In use of the device as above described, it will be apparent that upon actuating the same to project the lipstick into position for application to the lips, the lamp will be lit to project a light beam forwardly of the lipstick for illumination of the lips during the operation of applying the lipstick thereto. The device is simple and com-

5

pect in construction, may be readily carried upon the person and in emergency it may be used as an ordinary miniature flashlight.

It will be understood, of course, that the present invention is susceptible of various changes and modifications which may be made from time to time without departing from the general principles or real spirit thereof, and it is accordingly intended to claim the same broadly, as well as specifically, as indicated in the appended claims. 5 10

What is claimed as new and useful is:

1. In an article of the character described, in combination, a main cylindrical casing having an internal spiral groove in the rear portion thereof, a carrier for cosmetic or the like slidably fitted in the forward portion of said casing, said carrier having a rearwardly extending member terminating in a lateral pin engageable in said groove, a longitudinally slotted internal shell rotatably fitted in the rear portion of said casing, said pin projecting through said longitudinally slotted shell whereby upon rotation of said shell relatively to said casing the interengaged pin and groove effect axial shifting of the carrier in said casing, a flashlight battery and bulb assembly non-rotatably fitted in said internal shell with the bulb arranged to project light pe-

6

ripherally about and forwardly of said carrier, and a light transmitting plastic member extending longitudinally of said carrier, said member being adapted to receive light from said flashlight bulb for conductance and projection thereof forwardly of said carrier.

2. In an article of the character defined in claim 1 wherein switching means are provided internally of the casing for opening and closing the electric circuit from the battery to the bulb automatically upon movement of the carrier in one direction or the other.

RICHARD S. ROSS.
ROBERT A. WEINER.

References Cited in the file of this patent
UNITED STATES PATENTS

Number	Name	Date
975,465	Schnapka -----	Nov. 15, 1910
1,976,671	Parkin -----	Oct. 9, 1934
1,986,086	Weiss -----	Jan. 1, 1935
2,269,750	Baird -----	Jan. 13, 1942
2,358,867	Madan -----	Sept. 26, 1944
2,452,735	Devine -----	Nov. 2, 1948
2,461,790	Vaughn -----	Feb. 15, 1949