

(19) **DANMARK**

(10) **DK/EP 1993184 T4**



(12) **Oversættelse af ændret  
europæisk patentskrift**

Patent- og  
Varemærkestyrelsen

- 
- (51) Int.Cl.: **H 02 J 3/38 (2006.01)** **F 03 D 9/00 (2016.01)**
- (45) Oversættelsen bekendtgjort den: **2025-01-27**
- (80) Dato for Den Europæiske Patentmyndigheds bekendtgørelse om opretholdelse af patentet i ændret form: **2024-04-24**
- (86) Europæisk ansøgning nr.: **07009644.1**
- (86) Europæisk indleveringsdag: **2007-05-14**
- (87) Den europæiske ansøgnings publiceringsdag: **2008-11-19**
- (84) Designerede stater: **AT BE BG CH CY CZ DE DK EE ES FI FR GB GR HU IE IS IT LI LT LU LV MC MT NL PL PT RO SE SI SK TR**
- (73) Patenthaver: **Siemens Gamesa Renewable Energy A/S, Borupvej 16, 7330 Brande, Danmark**
- (72) Opfinder: **Nielsen, Kaj Skov, 1045 SW Mt. Pilchuck PI, 98027 Issaquah WA, USA**
- (74) Fuldmægtig i Danmark: **Zacco Denmark A/S, Arne Jacobsens Allé 15, 2300 København S, Danmark**
- (54) Benævnelse: **Fremgangsmåde til opstart af mindst en del af et vindkraftanlæg, vindkraftanlæg og anvendelse af vindkraftanlægget**
- (56) Fremdragne publikationer:  
**EP-A- 1 752 659**  
**WO-A-2004/099604**



# DESCRIPTION

## Description

**[0001]** The invention relates to a method of starting up at least a part of a wind power plant combinable to an external grid in particular after a complete collapse of the external grid.

**[0002]** A wind power plant is as a rule at least a part of an electrical power supply e.g. of a region or a country and is therefore connected to a grid as the transmission and/or distribution system of the voltage and/or the power of the electrical power supply. In general, all power plants need electrical power to start up. Under stable operation conditions a power plant delivers then a voltage and/or power to the grid. Under normal circumstances the electrical power for a start up of a power plant is provided from the transmission and/or the distribution system, thus from the grid of the electrical power supply.

**[0003]** But there can situations arise e.g. a normal outage or a disaster in which a collapse of at least a part of the grid occurs so that all or some power plants shut down. In this case no electrical power is available from the grid to restart a power plant. Therefore a power system or an electrical power supply comprising power plants and a transmission and/or distribution grid requires some contingency arrangements to enable a restart in the event that all or a part of the electrical power supply was shut down. The process of restoring the electrical power supply is commonly referred to as a black or a cold start.

**[0004]** In "An Introduction to Black Start", February 2001, Market Development, National Grid Company plc, is described that isolated so called black start power stations being started individually and gradually being reconnected to each other in order to form an interconnected electrical power supply or power system again. Under emergency conditions a black start station thereby receives the necessary electrical power for the restart and the start up respectively from a small auxiliary generating plant located on-site. Such an auxiliary generating plant can be a small gas turbine or a diesel plant, the minimum size of which is dependent on the size of the black start power station.

**[0005]** Thus when e.g. a total power breakdown of a grid to which a wind power plant is connected occurred and the wind power plant was shut down the wind power plant can first then be restarted and started up respectively when enough electrical power is available on the grid for the start up of the wind power plant. This causes a loss of production of electrical power by the wind power plant.

**[0006]** WO 2004/099604 A2 describes an operating method for a wind park. The park consists of a plurality of wind energy plants. The method is directed to the situation, where only a limited or even reduced reference power is supplied from a connected net due to the costs of the net-

power. According to the method the operating processes of each wind energy plant are controlled in a way that only a small amount of external electrical power is supplied from the net to the park.

**[0007]** It is therefore an object of the present invention to provide a method for a wind power plant in such a way that the start up of at least a part of the wind power plant is preferably accelerated.

**[0008]** The object is inventively achieved by a method of starting up at least a part of a wind power plant which is combinable to an external grid respectively substantially without any energy delivered from the external grid for the start up, the wind power plant comprises several wind turbines and at least one local electrical power source reversible combinable to at least one wind turbine of the wind power plant, wherein

- the wind power plant is disconnected from the external grid,
- one start up wind turbine or a group of start up wind turbines of the wind turbines of the wind power plant is isolated from the remaining wind turbines of the wind power plant,
- the one start up wind turbine or the group of start up wind turbines is connected to the local electrical power source and
- the one start up wind turbine or the group of start up wind turbines is started up using the electrical power delivered from the local electrical power source

wherein the wind power plant comprises several circuit breakers to close and open the needed electrical connections therefore. With this method it is possible to start up or to restart at least a part of the wind power plant, thus at least some wind turbines of the wind power plant which in operation is normally connected to an external grid e.g. after a complete collapse of the entire external grid substantially without any electrical power or energy delivered from the external grid for the start up. The external grid is normally a power transmission and/or distribution grid of an electrical power supply. The external grid can be a local grid or a regional grid or a grid in a larger area. According to the invention the electrical power for the start up is exclusively provided from a small local electrical power source which is substantially independently operated from the external grid and can be connected to at least one start up wind turbine or a group of start up wind turbines of the wind power plant. Thus the start up in particular the restart of at least a part of the wind power plant is independently from an external grid and thus simplified and accelerated. This results in a higher availability of the wind power plant and in better yield for a wind power plant operator because the production of electrical power is resumed faster e.g. after a power drop. It is clear that the method of start up at least a part of the wind power plant is preferably executed when the wind conditions are sufficient for a stable operation of the wind turbines of the wind power plant. As a rule thereby all operable wind turbines of the wind power plant are started up.

**[0009]** According to the invention a next wind turbine or a next group of wind turbines of the wind power plant is started up using the electrical power delivered from the one start up wind turbine or the group of start up wind turbines in particular when a stable operation of the one start up wind turbine or the group of start up wind turbines is achieved. A stable operation of a

start up or any other wind turbine means that the power output, the output voltage and/or the frequency of the output voltage of the wind turbine are substantially stable, thus in predetermined ranges under given wind conditions.

**[0010]** According to the invention single wind turbines or groups of wind turbines of the wind power plant are successively started up using the electrical power delivered from one or more start up and/or other wind turbines of the wind power plant which are preferably in stable operation.

**[0011]** Thus the wind power plant is started up stepwise or gradually. The more electrical power is available within the wind power plant the faster the remaining wind turbines can be started up until preferably all wind turbines of the wind power plant are started up.

**[0012]** According to the invention the wind power plant comprises at least one central power plant controller which is linked with the wind turbines and controls the start up of the wind power plant. The central power plant controller thereby controls preferably the production and consumption of electrical power in the wind power plant by monitoring the output voltages and the frequencies of the output voltages of the wind turbines. The central power plant controller is reversible combinable to the local power source.

**[0013]** According to the invention the wind power plant comprises several circuit breakers operated from the central power plant controller to close and open electrical connections. Thus the central power plant controller can control which start up wind turbine or which group of start up wind turbines is connected to the local power source for the start up. Furthermore the central power plant controller can control which wind turbine or which group of wind turbines is connected for the further start up to one or several already started up start up wind turbines or other already started up wind turbines.

**[0014]** According to a further embodiment of the invention the wind power plant is reconnected to the external grid when a predetermined number of wind turbines of the wind power plant is in stable operation what means as mentioned above that the wind turbines maintain the power output, the output voltage and/or the frequency of the output voltage substantially stable within predetermined ranges under given wind conditions. By that proceeding it is possible to deliver already electrical power to the external grid even before all wind turbines of the wind power plant are in operation or in stable operation what is positive for the yield of the wind power plant operator. The predetermined number of wind turbines depends thereby from the type of the wind turbines of the wind power plant in particular from the output voltage and/or the power output of the respective type of wind turbine.

**[0015]** According to an alternative the wind power plant is first preferably completely run up in a stable open-circuit operation and then reconnected to the external grid.

**[0016]** The wind power plant is particularly combinable to the external grid via a transformer and/or via a frequency synchronising device. Thus the output voltage of the wind power plant

can be transformed and/or the wind power plant can be connected to the external grid when the frequencies of the output voltage of the wind power plant and the voltage on the external grid are at least substantially equal to each other.

**[0017]** In a further development of the invention the electrical power deliverable from the wind power plant is used for a black or cold start of at least a part of the external grid to establish the voltage and/or the power on the external grid. The voltage and/or the power of the external grid can be only established by the voltage and/or the power delivered from the wind power plant or by the voltage and/or the power delivered from the wind power plant in combination with a voltage and/or a power delivered from at least one other voltage or power source. The other voltage or power source can thereby be at least another wind power plant, a cogeneration plant or a photovoltaic plant.

**[0018]** According to another variant of the invention the central power plant controller is linked with the wind turbines via a communication network. The communication network can thereby be a wireless or a wired communication network.

**[0019]** According to an embodiment of the invention the local power source is or comprise a battery preferably a large battery, an uninterruptible power source (UPS) or a generator. The local power source can be or can comprise e.g. a diesel generator or fuel cell. The size of the local power source is thereby adapted to the voltage and/or the power necessary for start up at least one wind turbine or at least one group of wind turbines. E.g. a large 3,6 MW wind turbine requires about 690 V and about 30 kW for the control, the motors and the inverters, which is a little less than 1 % of the power of the wind turbine. The duration of the local power source can be from a few minutes up to one hour.

**[0020]** The invention will in the following be explained in more detail with reference to the schematic drawings, where

FIG 1

shows schematically an exemplary wind power plant and

FIG 2

shows the wind power plant of FIG 1 connected to an external grid via a frequency synchronising device.

**[0021]** FIG 1 shows schematically a wind power plant 1. The wind power plant 1 is combinable to an external grid 2 via a transformer 3. In case of the present embodiment the grid 2 is a local or small AC island grid connected by a HDVC link 21 (high voltage direct current) to a main AC grid 20. The HDVC link 21 comprises in a common manner on the side of the grid 2 a rectifier 22 and on the side of the main grid 20 an inverter 23. During a normal operation and under given sufficient wind conditions the wind power plant 1 delivers electrical power and/or an output voltage to the grid 2. In the case when the wind power plant 1 was shut down e.g. because of high wind conditions the wind power plant can be started up or restarted with

electrical power delivered from the grid 2.

**[0022]** But there can situations arise like normal outages or disasters in which a complete collapse of an entire grid occurs and nearly all power plants connected to the grid shut down. Then a black or cold start of the entire power system or the entire electrical power supply comprising power plants and a transmission and/or distribution system and the entire grid respectively is necessary. In such a situation a wind power plant can first then be started up or restarted when enough electrical power is available on the grid for the start up which can lead to a delay of the start up of the wind power plant even when the wind conditions are adequate for the operation of the wind power plant.

**[0023]** In particular to overcome this delay and/or to contribute to a black start of at least a part of a grid the wind power plant 1 is prepared to start up or to restart substantially without any energy delivered from the grid particularly from the grid 2.

**[0024]** In case of the present embodiment the wind power plant 1 therefore comprises several wind turbines 4, a central power plant controller 5, several circuit breakers  $CB_1 - CB_x$  and a small local power source 6.

**[0025]** In case of the present embodiment respectively three wind turbines 4 are combined to one group  $GP_1 - GP_x$  of wind turbines 4. But it is also possible that a group comprises one, two or more wind turbines 4. Each group  $GP_1 - GP_x$  of wind turbines 4 is combinable to a power supply line 7 of the wind power plant 1 by one of the circuit breakers  $CB_4 - CB_x$ . The local power source 6 is combinable to the power supply line 7 by the circuit breaker  $CB_3$  and the transformer 3 is combinable to the power supply line 7 by the circuit breaker  $CB_2$ . The central power plant controller 5 is also connected to the power supply line 7 and operates the circuit breakers  $CB_1 - CB_x$  to open and close the electrical connection. The groups  $GP_1 - GP_x$  of wind turbines 4 and the central power plant controller 5 are reversible combinable to the local power source 6 by the circuit breakers  $CB_3 - CB_x$ .

**[0026]** The wind turbines 4 are additionally connected to the central power plant controller 5 via a fast communication network 11. In case of the present embodiment the fast communication network is a wired network e.g. an Ethernet. But the communication network can also comprise fibre optic cables. The communication network could also be a wireless network e.g. based on electromagnetic waves or any other communication network providing the necessary band-width for a fast data transmission like a set point from the central power plant controller 5 to a wind turbine 4. Thus the central power plant controller 5 can communicate with all the wind turbines 4 of the wind power plant 1 in particular with each not explicitly shown turbine controller of each wind turbine 4.

**[0027]** The central power plant controller 5 controls and balances the production and consumption of electrical power in the wind power plant 1 by monitoring the output voltage and the frequency of the output voltage during the normal operation, a start up and a black start

sequence. The output voltages at the turbine controllers of the wind turbines 4 are regulated based on a measurement of the output voltage of the wind power plant 1 at the central point 8. The production levels at the individual wind turbines 4 are regulated based on a measured frequency by a frequency controller. The frequency controller may be placed locally at the turbine controller of a wind turbine 4 communicating with the central power plant controller 5 or centrally at the central power plant controller 5 or a combination of both. The regulation of the output voltage and the frequency may be based on a PID-controller (proportional plus integral plus derivative), a fuzzy controller, a neural network or on a combination thereof.

**[0028]** For the explanation of the invention it is assumed that there was a failure of the HVDC link 21 from the grid 2 to the main grid 20. Thus the grid 2 collapsed and the wind power plant 1 shut down. Now the wind power plant 1 can be used to restore or to establish the electrical power and/or the voltage on the external grid 2 granted that the wind speed is in the normal or in an adequate operating range for the operation of the wind power plant 1.

**[0029]** In the first step the circuit breaker  $CB_3$  is closed which can be done e.g. by hand to connect the central power plant controller 5 to the small local power source 6 which can be a battery or general a UPS (uninterruptible power source) or a generator. Thus the central power plant controller 5 is supplied with electrical power from the local power source 6 and can control the start up and the black start sequence in particular the central power plant controller 5 can open and close the circuit breakers. Then all not yet opened circuit breakers  $CB_1 - CB_x$  except circuit breaker  $CB_3$  are opened. Thus the wind power plant 1 is disconnected from the external local transmission and distribution grid 2. This ensures that no electrical power is fed back to the transmission and distribution lines of the external grid 2 before the wind power plant 1 is in a stable operation.

In case of the present embodiment the wind turbines 4 of the group  $GP_1$  are the start up wind turbines 4. In consequence of the open circuit breakers  $CB_4 - CB_x$  the groups  $GP_1 - GP_x$  of wind turbines 4 are isolated from each other.

**[0030]** For starting up the start up wind turbines 4 of group  $GP_1$  the circuit breaker  $CB_4$  operated by the central power plant controller 5 is closed and the wind turbines 4 of group  $GP_1$  are connected to the power supply line 7 and to the local power source 6. Subsequently the start up wind turbines 4 of group  $GP_1$  of the wind power plant 1 are started up under control of the central power plant controller 5 using the electrical power delivered from the local power source 6. Thereby each generator and each inverter of each wind turbine 4 of group  $GP_1$  are adjusted and operated in such a way that the start up function is supported. In this manner it is possible with each wind turbine controller of each wind turbine 4 to control e.g. the magnetising currents of the respective generator of the wind turbine 4 so that the start up of a wind turbine 4 of the wind power plant 1 and thus of the whole wind power plant 1 can be performed without any energy or power supply of a external grid like the grid 2.

When a stable operation of the group  $GP_1$  of start up wind turbines 4 is achieved what means that the output voltages and the frequency of the output voltages of the wind turbines 4 of group  $GP_1$  are in predetermined ranges under given wind conditions the next group  $GP_2$  of

wind turbines 4 of the wind power plant 1 is started up using preferably the electrical power delivered from the start up wind turbines 4 of group  $GP_1$  which are in a stable operation. In this situation the circuit breaker  $CB_5$  is closed and the circuit breaker  $CB_3$  is opened. But it is also possible to leave the circuit breaker  $CB_3$  closed and use also the power delivered from the local power source 6 to start up the wind turbines 4 of group  $GP_2$ . By the way when the circuit breaker  $CB_3$  is opened the power for operating the central power plant controller 5 is delivered from the start up wind turbines 4.

**[0031]** In this manner all groups  $GP_2 - GP_x$  of wind turbines 4 of the wind power plant 1 and thus the whole wind power plant 1 are successively started up using the electrical power delivered from one or more start up and/or other wind turbines 4 of the wind power plant 1 when the electrical power delivering wind turbines in a stable operation.

**[0032]** According to a development of the invention the wind power plant 1 is gradually reconnected to the external grid 2 when a predetermined number of wind turbines 4 of the wind power plant 1 is in a stable operation. The predetermined number of wind turbines 4 in stable operation depends thereby on the nominal output voltages of the type of wind turbines 4 and/or on the capacity of the external grid 2. For the reconnection of the wind power plant 1 to the external grid 2 the circuit breaker  $CB_2$  and the circuit breaker  $CB_1$  are closed by the central power plant controller 5.

**[0033]** The electrical power and/or voltage delivered from the wind power plant 1 to the external grid 2 is in case of the present embodiment used for the black or cold start of the external grid 2 in particular to restore or to establish the voltage and/or the power on the external grid 2 before the external grid 2 is connected back to the main grid 20 by the HVDC link 21. As the load increases the wind turbines 4 use their frequency controller to manage the output voltage up to the level that can be sustained by the available wind.

**[0034]** From the present embodiment of the invention it becomes clear that a wind power plant 1 can be started up or restarted substantially without any energy delivered from an external grid 2 which can be part of a main grid. The electrical power delivered from the wind power plant 1 during and/or after the start up of the wind power plant 1 can be used for a black or a cold start at least of the external grid 2 in particular to restore or establish the voltage and/or the power on the grid 2. Thus the delay up to a power delivery of the wind power plant 1 to the grid 2 e.g. after a grid outage can be reduced. The described proceeding could be used under normal outages or in disaster situations where conventional courses may take longer to restore full power production. So if the wind conditions are adequate a wind power plant as a black start station like the wind power plant 1 is able to restore the voltage and/or the power faster than a thermal plant as a black start station on an external grid, where temperature increases is a critical factor and a rapid temperature increase potentially can cause damage to the equipment.

**[0035]** The wind power plant 1 in particular the black or cold start function of the wind power

plant 1 can be used to establish a external grid like the local grid 2 independently or in combination with at least another voltage or power source in form of another wind power plant, a small cogeneration plant, a photo voltaic plant or any other proper plant. The wind power plant 1 can further be used to re-establish a grid in a larger area.

**[0036]** In case of the present embodiment it is alternatively possible that the wind power plant 1 is run up in an open-circuit operation and when stable in operation reconnected to the grid 2 by the circuit breakers  $CB_1$  and  $CB_2$  to produce power in particular when the HVDC link 21 is connected.

**[0037]** As shown in FIG 2 it is also possible to use additionally a frequency synchronising device 9 connected to the wind power plant controller 5. It is then possible to connect the wind power plant 1 to the grid 2 when the frequency of the output voltage of the wind power plant 1 and the frequency of the voltage of the grid 2 are substantially equal to each other.

**[0038]** It is remarked that the described example of the invention is only an embodiment of the invention. Thus other embodiments of the invention are possible without leaving the scope of the invention.

**[0039]** Normally the central power plant controller 5 is adjusted for executing one of the inventive methods namely to start up the wind power plant 1 and/or to control the black start sequence of the wind power plant 1. For this purpose the central power plant controller 5 e.g. in form of a computer or computing unit comprises a respective computer program.

**[0040]** In case of a battery as local power source 6 of the wind power plant 1, this battery can be loaded by the wind turbines 4 of the wind power plant 1. Preferably there exists a monitored load cycle of the battery that the battery is preferably always in the condition for a start up and/or black start sequence. The load can be easily done by closing the circuit breaker  $CB_3$  operated by the central power plant controller 5.

**[0041]** The invention has additionally to the advantages already mentioned the advantage of a potentially better service for local utility customers connected to the grid when the grid is restored faster after a power loss.

**[0042]** Furthermore by the invention there is faster more power available to a grid operator providing more flexibility for restoring the grid.

**[0043]** Especially with more wind power plants distributed over a larger geographical area the ability of any of these wind power plants to contribute to restoring power on a grid increases even though any individual wind power plant may not have the wind resources needed to supply this service. When wind power reaches high level of penetration, it will become more urgent for the grid stability to be able to restore supply from this resource faster.

# REFERENCES CITED IN THE DESCRIPTION

## Cited references

This list of references cited by the applicant is for the reader's convenience only. It does not form part of the European patent document. Even though great care has been taken in compiling the references, errors or omissions cannot be excluded and the EPO disclaims all liability in this regard.

## Patent documents cited in the description

- WO2004099604A2 [0006]

## Non-patent literature cited in the description

- An Introduction to Black StartMarket DevelopmentNational Grid Company plc20010200 [0004]

**Patentkrav**

1. Fremgangsmåde til opstart af mindst en del af et vindkraftanlæg (1), som kan kombineres med et eksternt forsyningsnet (2) i det væsentlige uden nogen energi leveret fra det eksterne forsyningsnet (2) for opstarten,

- 5            hvor vindkraftanlægget (1) omfatter  
             flere vindmøller (4) og  
             mindst en lokal effektkilde (6), der kan kombineres med mindst en vindmølle  
             (4),  
             hvor
- 10           - vindkraftanlægget (1) afbrydes fra det eksterne forsyningsnet (2),  
             - en opstart-vindmølle (4) eller en gruppe ( $GP_1 - GP_x$ ) af opstart-vindmøller (4)  
             af vindmøllerne (4) af vindkraftanlægget (1) isoleres fra de resterende  
             vindmøller (4),  
             - den ene opstart-vindmølle (4) eller gruppen ( $GP_1 - GP_x$ ) af opstart-vindmøller
- 15           (4) forbindes med den lokale effektkilde (6), og  
             - den ene opstart-vindmølle (4) eller gruppen ( $GP_1 - GP_x$ ) af opstart-vindmøller  
             (4) startes op ved anvendelse af den effekt, der leveres fra den lokale  
             effektkilde (6), og  
             hvor vindkraftanlægget (1) omfatter flere effektafbrydere ( $CB_1 - CB_x$ ) for at
- 20           lukke og åbne de nødvendige elektriske forbindelser herfor,  
             hvor, når der er opnået en stabil drift af den ene opstart-vindmølle (4) eller  
             gruppe ( $GP_1 - GP_x$ ) af opstart-vindmøller (4), fortrinsvis en næste vindmølle (4)  
             eller en næste gruppe ( $GP_1 - GP_x$ ) af vindmøller (4) af vindkraftanlægget (1)  
             startes op ved anvendelse af den effekt, der leveres fra den ene opstart-
- 25           vindmølle (4) eller gruppen ( $GP_1 - GP_x$ ) af opstart-vindmøller (4),  
             hvor enkelte vindmøller (4) eller grupper ( $GP_1 - GP_x$ ) af vindmøller (4) af  
             vindkraftanlægget (1) startes successivt op ved anvendelse af den effekt, der  
             leveres fra en eller flere opstart- (4) og/eller andre vindmøller (4) af  
             vindkraftanlægget (1), fortrinsvis under stabil drift,
- 30           hvor vindkraftanlægget (1) omfatter mindst en central kraftanlægsstyreenhed  
             (5), som er forbundet med vindmøllerne (4) og styrer opstarten af  
             vindkraftanlægget (1),

hvor den centrale kraftanlægsstyreenhed (5) forbindes reversibelt med den lokale effektkilde (6), og

hvor de flere effektafbrydere ( $CB_1 - CB_x$ ) drives fra den centrale kraftanlægsstyreenhed (5) for at lukke og åbne de elektriske forbindelser.

5

**2.** Fremgangsmåde ifølge krav 1, hvor vindkraftanlægget (1) forbindes igen med det eksterne forsyningsnet (2), når et forudbestemt antal af vindmøller (4) af vindkraftanlægget (1) er i stabil drift.

10 **3.** Fremgangsmåde ifølge krav 1 eller 2, hvor vindkraftanlægget (1) igangsættes under en drift med åbent kredsløb og derefter forbindes igen med det eksterne forsyningsnet (2).

**4.** Fremgangsmåde ifølge et hvilket som helst af kravene 1 til 3, hvor  
15 vindkraftanlægget (1) kan kombineres med det eksterne forsyningsnet (2) via en transformer (3).

**5.** Fremgangsmåde ifølge et af kravene 1 til 4, hvor vindkraftanlægget (1) kan  
20 kombineres med det eksterne forsyningsnet (1) via en frekvenssynkroniserende indretning (9).

**6.** Fremgangsmåde ifølge et af kravene 1 til 5, hvor effekten, som kan leveres fra vindkraftanlægget (1), anvendes til en sort eller en kold start af mindst en del af det eksterne forsyningsnet (2) for at etablere spændingen og/eller effekten i det eksterne  
25 forsyningsnet (2).

**7.** Fremgangsmåde ifølge krav 6, hvor spændingen og/eller effekten fra det eksterne forsyningsnet (2) kun etableres ved hjælp af spændingen og/eller effekten, der leveres fra vindkraftanlægget (1), eller ved hjælp af spændingen og/eller effekten, der  
30 leveres fra vindkraftanlægget (1), i kombination med mindst en anden spændings- eller effektkilde.

**8.** Fremgangsmåde ifølge krav 7, hvor den anden spændings- eller effektkilde er et andet vindkraftanlæg, et cogeneration-anlæg eller et fotovoltaisk anlæg.

**9.** Fremgangsmåde ifølge et af kravene 1 til 8, hvor den centrale kraftanlægstyreenhed (5) forbindes med vindmøllerne via et kommunikationsnetværk (11).

**10.** Fremgangsmåde ifølge et af kravene 1 til 9, hvor den lokale effektkilde (6) er eller omfatter et batteri, en afbrydelsessikker effektkilde (UPS) eller en generator.

# DRAWINGS

Drawing

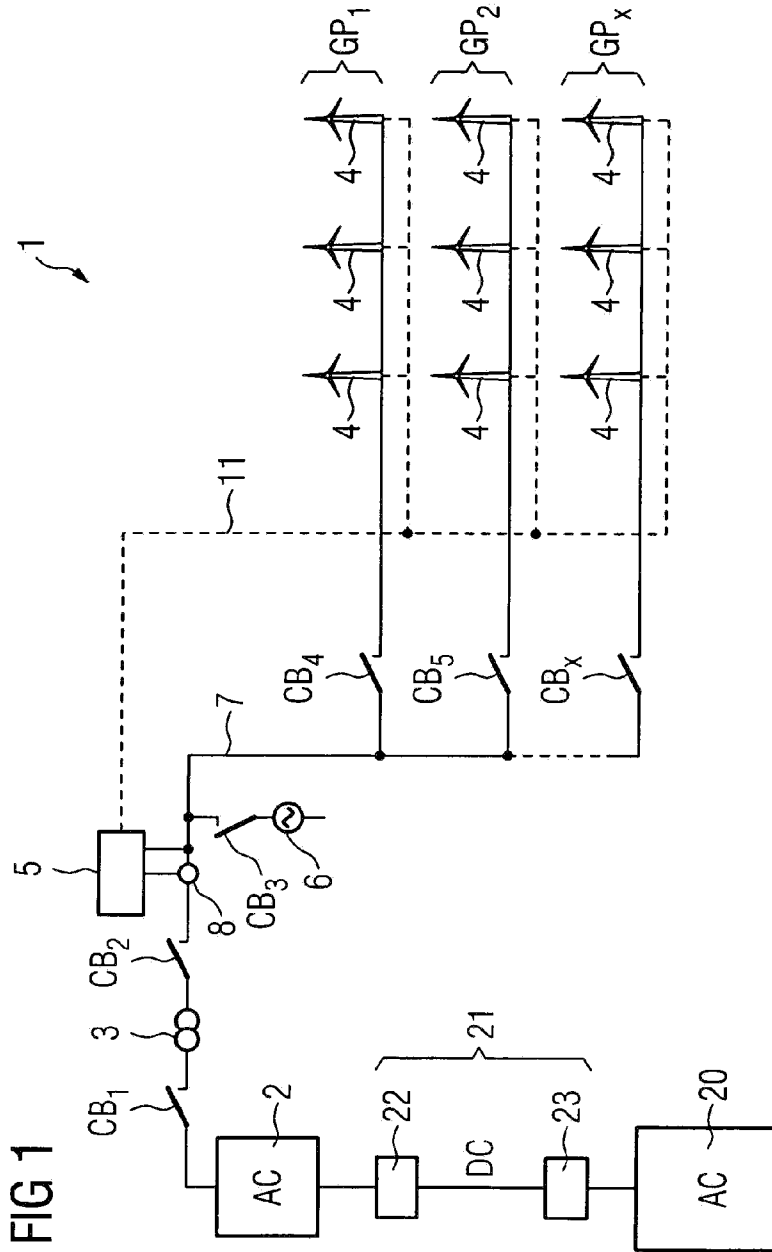

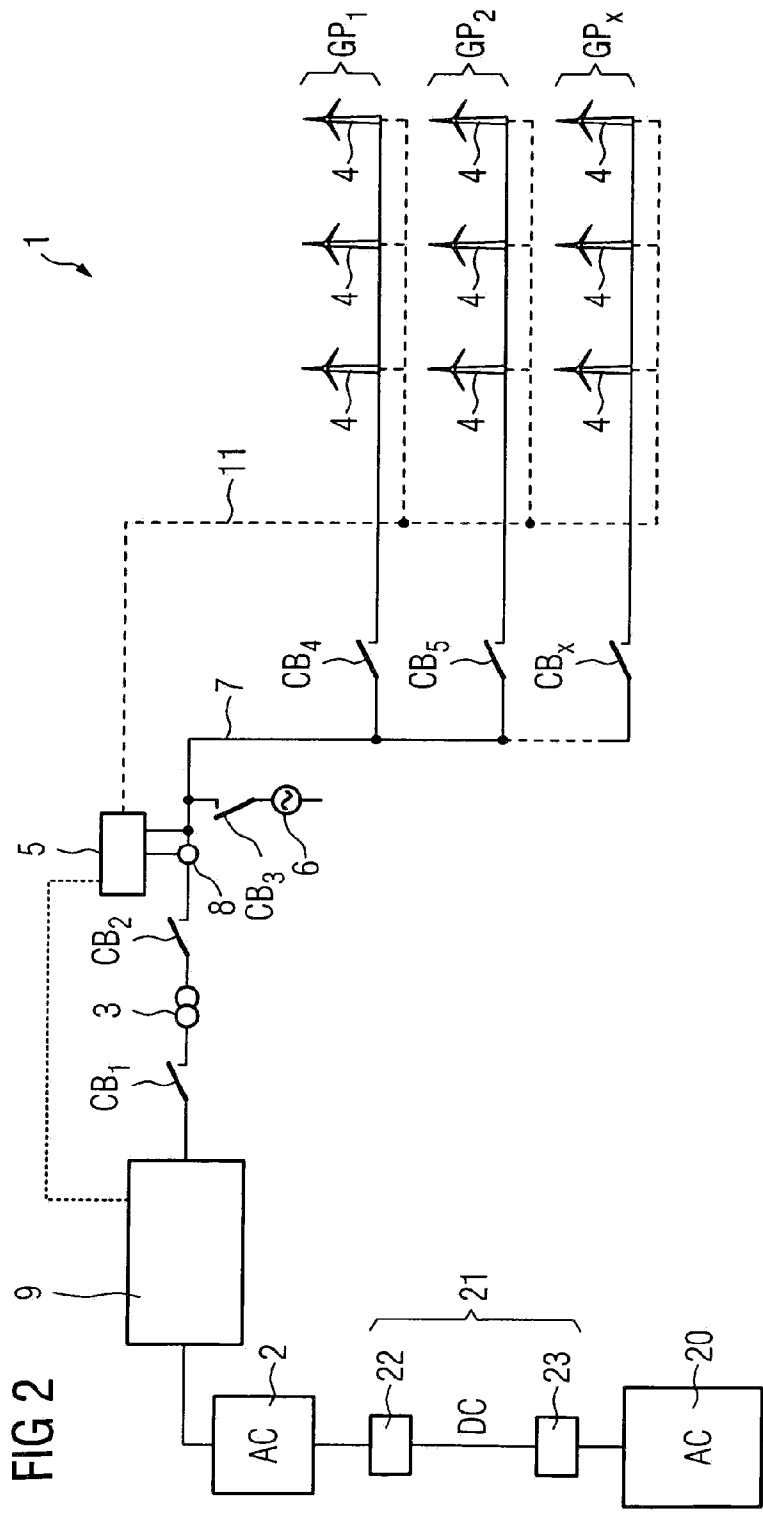

FIG 2