



US00D968294S

(12) **United States Design Patent**
Sandys et al.

(10) **Patent No.:** **US D968,294 S**

(45) **Date of Patent:** **** Nov. 1, 2022**

- (54) **VEHICLE INSTRUMENT PANEL**
- (71) Applicant: **JAGUAR LAND ROVER LIMITED**,
Coventry (GB)
- (72) Inventors: **Jonathan Sandys**, Coventry (GB);
Malcolm Whyte, Coventry (GB);
Mariusz Bekas, Coventry (GB)
- (73) Assignee: **JAGUAR LAND ROVER LIMITED**,
Coventry (GB)

D853,919 S *	7/2019	Hazumi	D12/192
D860,892 S *	9/2019	Ohmori	D12/192
D863,162 S *	10/2019	Schneider	D12/192
D864,815 S *	10/2019	Ray	D12/192
D877,012 S *	3/2020	Ali	D12/192
D881,095 S *	4/2020	Finney	D12/192
D887,954 S *	6/2020	Xu	D12/415
D889,340 S *	7/2020	Lun	D12/192
D889,381 S *	7/2020	Xu	D12/415
D908,075 S *	1/2021	Park	D12/415
D908,569 S *	1/2021	Bernal	D12/192
D909,941 S *	2/2021	Perry	D12/192
D915,964 S *	4/2021	Yu	D12/192

(**) Term: **15 Years**

* cited by examiner

(21) Appl. No.: **29/743,750**

Primary Examiner — Susan E Krakower

Assistant Examiner — Jerry Shiuan-Hua Hsu

(22) Filed: **Jul. 23, 2020**

(74) *Attorney, Agent, or Firm* — Reising Ethington P.C.

(30) **Foreign Application Priority Data**

Jan. 24, 2020 (EM) 007552955-0010

(51) **LOC (13) Cl.** **12-16**

(52) **U.S. Cl.**
USPC **D12/192**

(58) **Field of Classification Search**
USPC D12/86, 90–92, 114, 163, 167, 169–170,
D12/174, 175, 192, 196, 216, 345, 415;
D14/126–129, 133, 373, 374, 388, 389;
D15/17, 28, 14, 15, 22–26, 31, 33
CPC B60R 7/04; B60R 7/06; B60R 7/08; B60K
37/00; B60K 37/02; B60K 37/04; B60K
37/06

See application file for complete search history.

(56) **References Cited**

U.S. PATENT DOCUMENTS

D795,146 S *	8/2017	Ogawa	D12/192
D847,054 S *	4/2019	Yamada	D12/192

(57) **CLAIM**

The ornamental design for a vehicle instrument panel, as shown and described.

DESCRIPTION

FIG. 1 is a front left perspective view of the vehicle instrument panel, showing our new design;
FIG. 2 is a front view thereof;
FIG. 3 is a right side view thereof, enlarged for ease of illustration;
FIG. 4 is a left side view thereof, enlarged for ease of illustration;
FIG. 5 is a top view thereof;
FIG. 6 is a bottom view thereof;
FIG. 7 is a rear right perspective view thereof; and,
FIG. 8 is a rear view thereof.

The broken lines illustrate portions of the vehicle instrument panel that form no part of the claimed design.

1 Claim, 8 Drawing Sheets

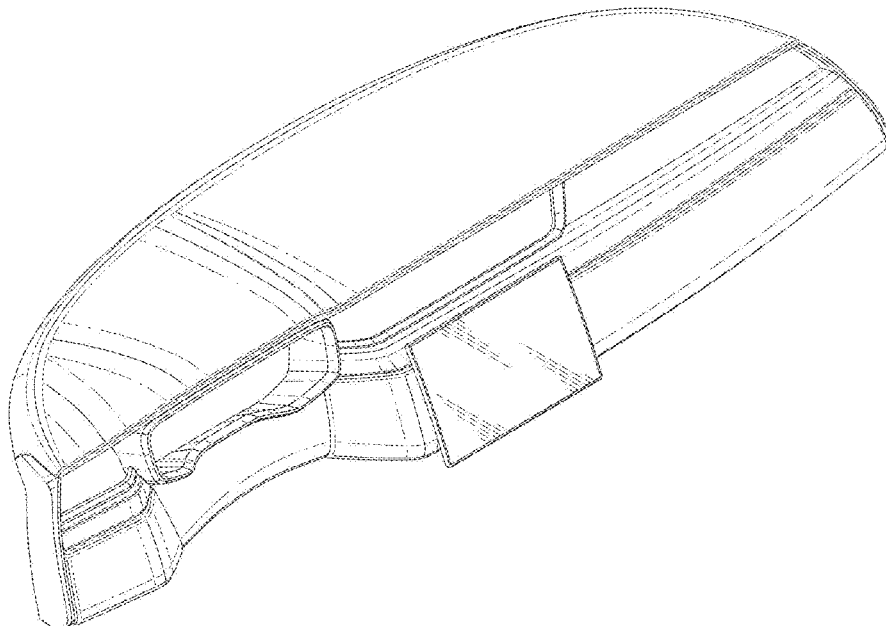

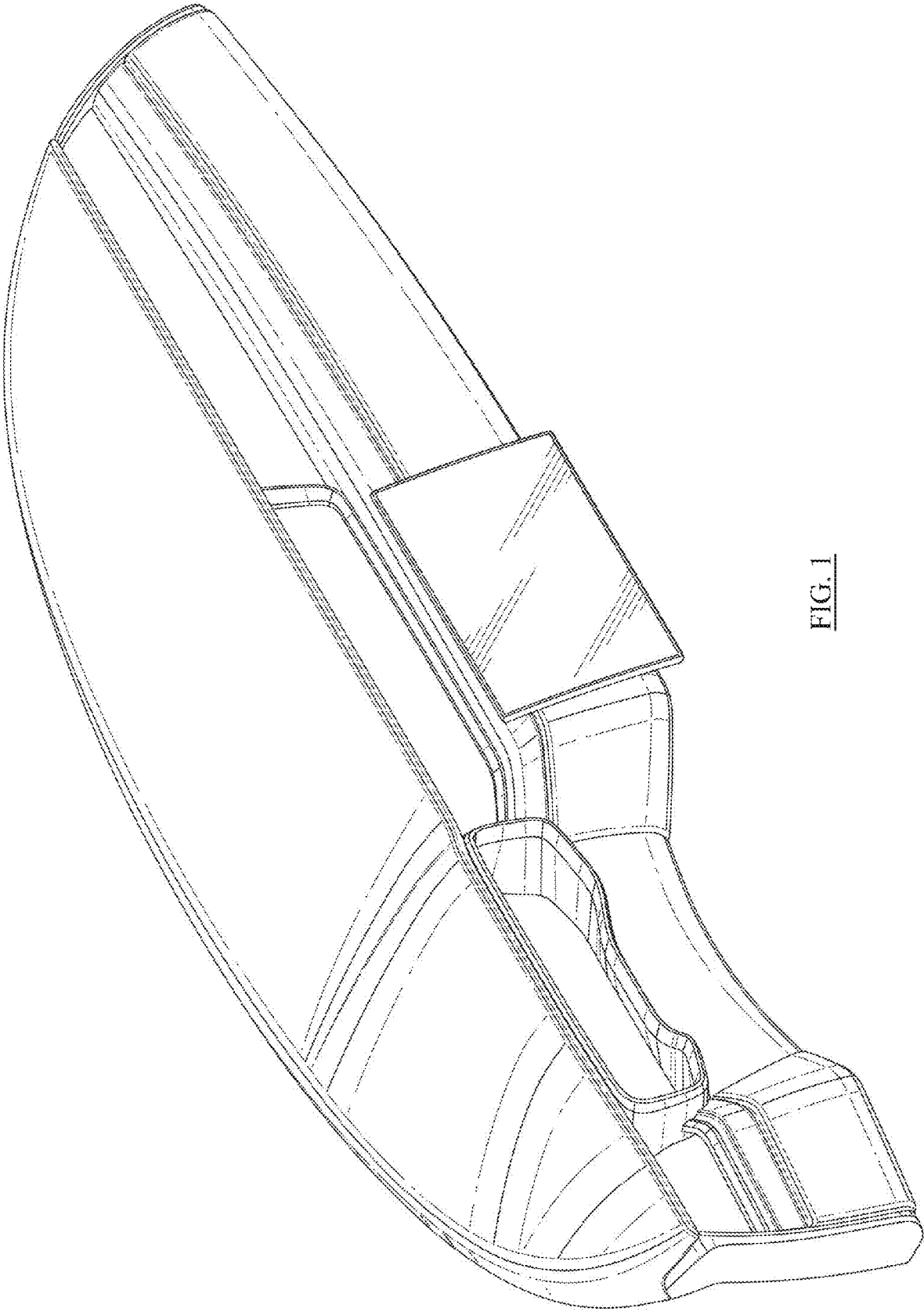

FIG. 1

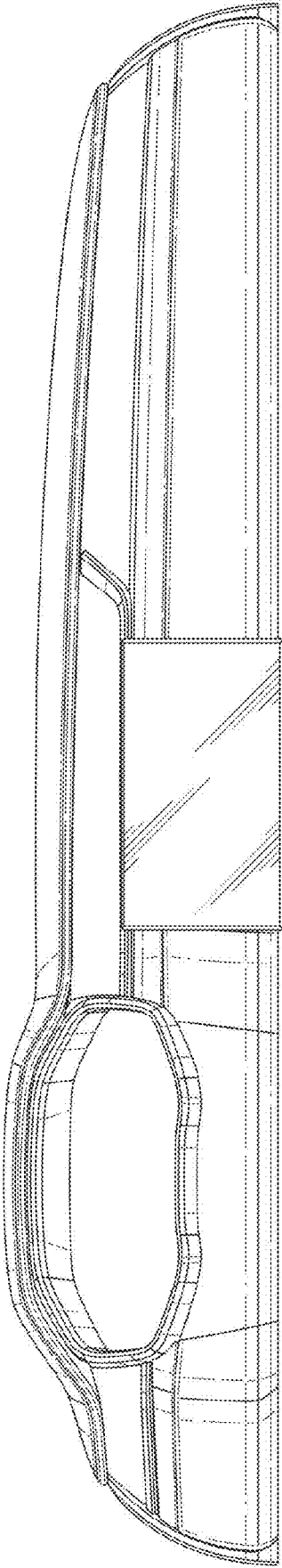

FIG. 2

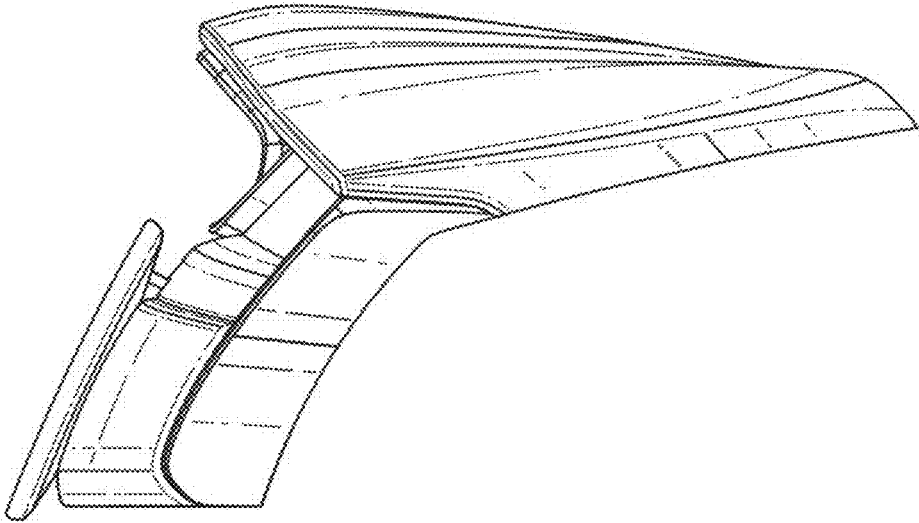

FIG. 3

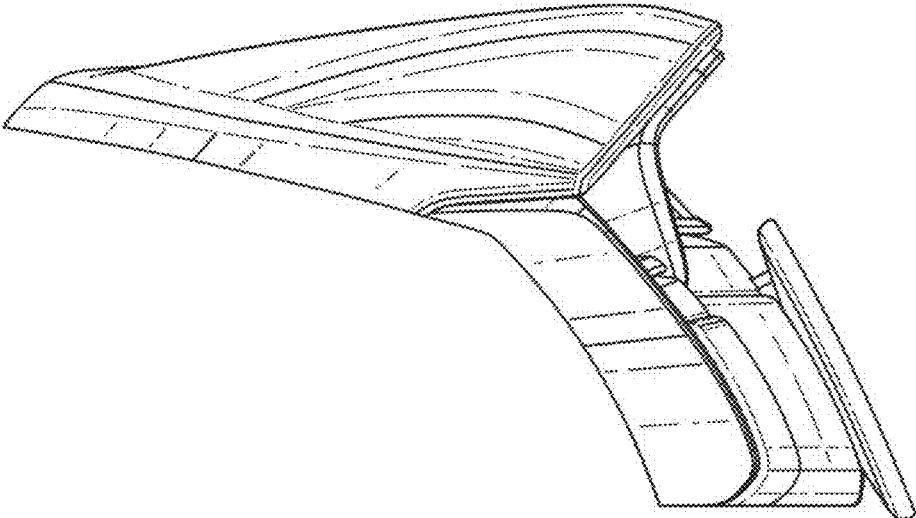

FIG. 4

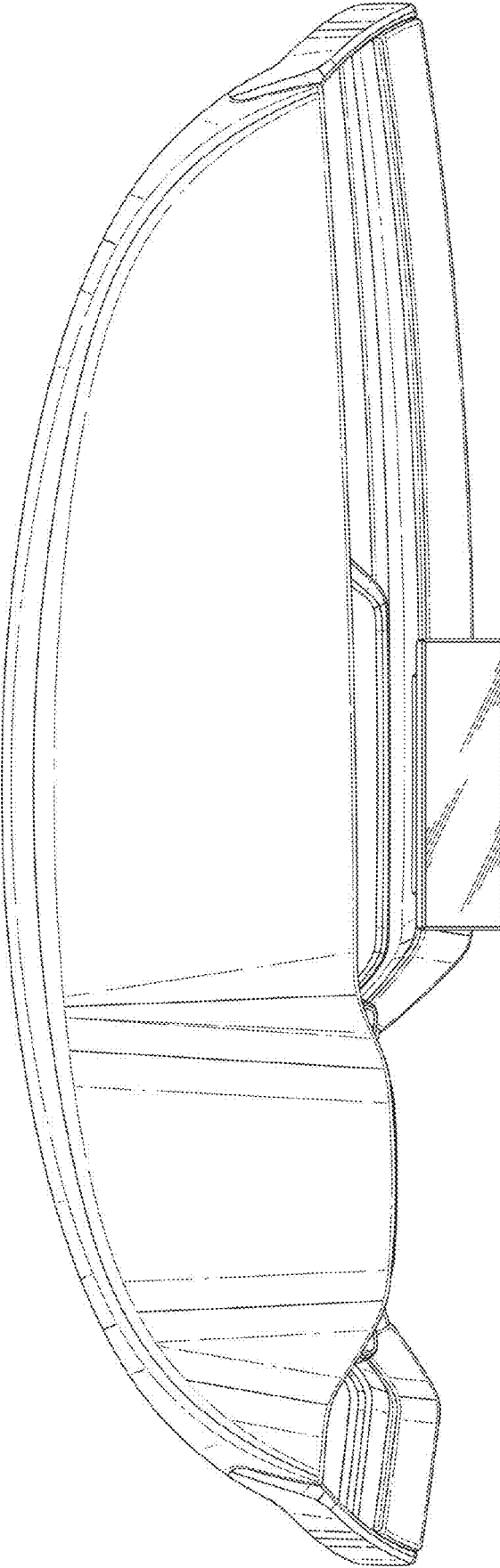

FIG. 5

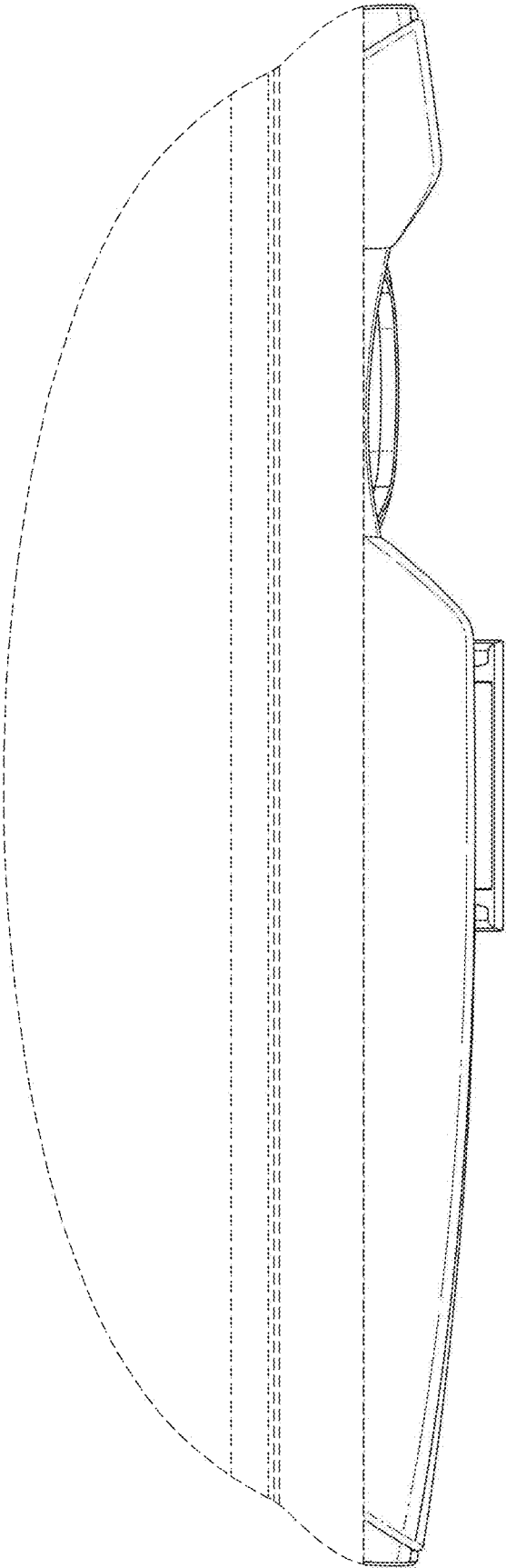

FIG. 6

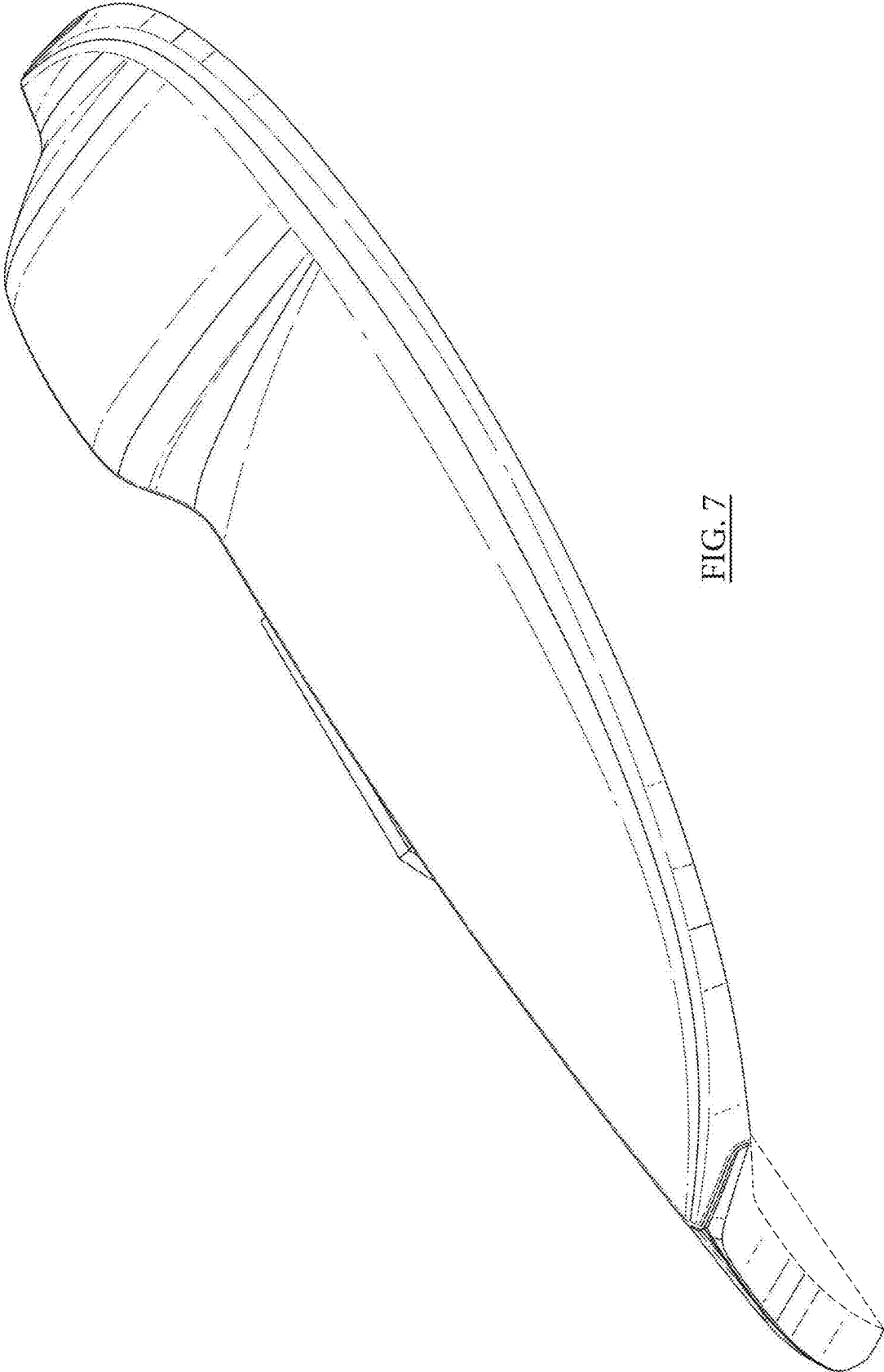

FIG. 7

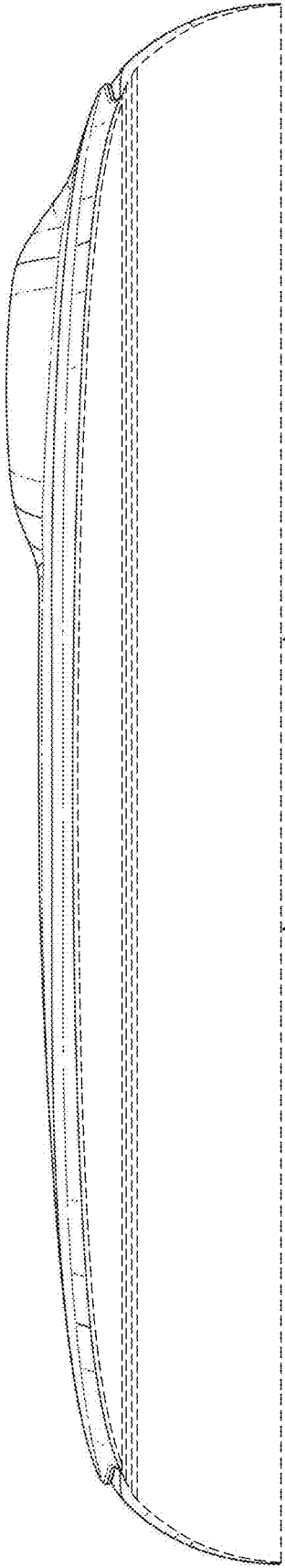

FIG. 8