



(12) **DEMANDE DE BREVET CANADIEN
CANADIAN PATENT APPLICATION**

(13) **A1**

(22) Date de dépôt/Filing Date: 2021/06/02
(41) Mise à la disp. pub./Open to Public Insp.: 2021/12/19
(30) Priorité/Priority: 2020/06/19 (CH00734/20)

(51) Cl.Int./Int.Cl. *G01S 5/14* (2006.01),
H04B 1/3888 (2015.01), *H04W 12/033* (2021.01),
H04W 4/02 (2018.01), *H04W 4/029* (2018.01),
H04W 4/12 (2009.01), *H04W 56/00* (2009.01),
H04W 64/00 (2009.01)

(71) Demandeur/Applicant:
LEGIC IDENTSYSTEMS AG, CH

(72) Inventeurs/Inventors:
TROESTER, RAINER, CH;
PLUSS, MARCEL, CH

(74) Agent: SMART & BIGGAR LLP

(54) Titre : APPAREIL ELECTRONIQUE
(54) Title: ELECTRONIC DEVICE

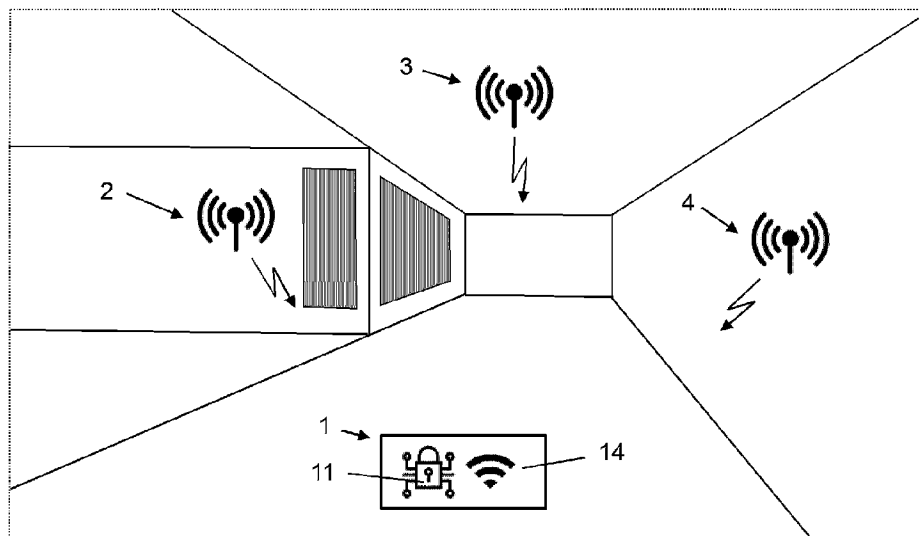

(57) **Abrégé/Abstract:**

An electronic device for securely determining current location information regarding the electronic device, the electronic device comprising a radio communication module and a secure element including a processor and a memory, the secure element being connected to the radio communication module and the processor being configured to obtain one or more beacon messages from one or more beacon devices; determine in real-time the current location information, the current location information comprising one or more distances between the electronic device and the beacon devices; and store the current location information in the memory of the secure element.

ABSTRACT

An electronic device for securely determining current location information regarding the electronic device, the electronic device comprising a radio communication module and a secure element including a processor and a memory, the secure element being
5 connected to the radio communication module and the processor being configured to obtain one or more beacon messages from one or more beacon devices; determine in real-time the current location information, the current location information comprising one or more distances between the electronic device and the beacon devices; and store the current location information in the memory of the secure element.

10

ELECTRONIC DEVICE

FIELD OF THE DISCLOSURE

The present disclosure relates to an electronic device. In particular, the present disclosure relates to an electronic device for securely determining current location information regarding the electronic device, which includes a radio communication module and a secure element, a mobile phone fitted with a mobile phone case comprising the electronic device, a device configured to be worn or carried by a user comprising the electronic device, and a beacon device fixedly installed comprising the electronic device.

BACKGROUND OF THE DISCLOSURE

Electronic devices are commonplace in all areas of industry and commerce, and in many cases comprise integrated circuits (ICs), which are small semiconductor devices which feature a range of circuits, such as processors which execute program code, and processors which are specially configured for performing particular tasks. Other kinds of semiconductor devices include application specific integrated circuits (ASICs), for example.

In applications where secure execution is required, electronic devices typically feature a secure element, which is used to store sensitive data and run secure applications. These secure elements are typically printed onto the same circuit board as the rest of the ICs of the electronic device. Secure elements are used, for example, to store cryptographic keys such that the rest of the electronic device has no knowledge of, and cannot gain access to, the cryptographic keys. This is to ensure that any malware which may be executed on the electronic device cannot discover or manipulate the cryptographic keys. The cryptographic keys are typically stored in the secure element during manufacture and cannot be altered. Along with simply storing cryptographic keys, these secure elements often provide some additional limited functionality related to cryptography and security, often realized as application specific circuitry. These additional functions include cryptographic functions, functions for detecting tampering of the secure element or the host

device, functions for detecting side channel attacks, and so on. This small set of additional functions enables the secure element to, in a limited manner, authenticate credentials, for example, and provide and verify digital signatures.

5 In the electronic device, the secure element is typically used in conjunction with a general purpose processor. The general purpose processor executes custom program code, often also executing custom program code from a third party, and when use of the secure element is required, messages are sent to and received from the secure element, typically using a system bus.

10 Applications where the location of a device is required typically can be divided into outdoor and indoor applications. For outdoor applications, satellite based systems such as GPS are typically used, as they require only a GPS receiver. However, the accuracy of GPS and other such systems is limited. Indoor applications typically require several beacon devices to be installed in fixed locations, which emit radio waves allowing a device to determine a position, however, both the security and the inaccuracy of indoor based
15 positioning systems remain problems to be addressed.

SUMMARY OF THE DISCLOSURE

This disclosure may provide an electronic device, which electronic device does not have at least some of the disadvantages of the prior art. In particular, the present disclosure
20 may provide an electronic device comprising a radio communication module and a secure element.

According to the present disclosure, an electronic device for securely determining current location information regarding the electronic device comprises a radio communication module and a secure element including a processor and a memory, the secure
25 element being connected to the radio communication module. One or more beacon messages are received by the radio communication module from one or more beacon devices. The processor is configured to obtain, from the radio communication module, the one or more beacon messages. The processor is configured to determine in real-time the current location information, using transmission properties of the one or more beacon
30 messages, the current location information comprising one or more distances between

the electronic device and the beacon devices. The processor is configured to store the current location information in the memory of the secure element.

In an embodiment, the processor is further configured to read, from the one or more beacon messages one or more beacon identifiers, and store a particular beacon identifier
5 in the memory of the secure element, if the distance to the particular beacon device is below a pre-defined proximity threshold and if said distance is maintained for a pre-determined duration threshold.

In an embodiment, the processor is further configured to read, from the one or more beacon messages one or more beacon status indicators. The beacon status indicators
10 indicate a beacon device status and/or a beacon user status. The processor is configured to filter a particular beacon message, from the one or more beacon messages, using a filter parameter and the one or more beacon status indicators and/or a beacon signal strength. The filter parameter is a pre-defined filter parameter or a dynamically set filter parameter. The processor is configured to determine in real-time filtered current location
15 information, using transmission properties of the particular beacon message, and store filtered current location information in the memory of the secure element.

In an embodiment, the radio communication module comprises an ultra-wideband (UWB) radio. The processor is configured to obtain, from the radio communication module, one or more beacon messages received by the ultra-wideband radio from one or
20 more beacon devices.

In an embodiment, the processor is further configured to determine in real-time, using the one or more distances and a known arrangement of the beacon devices, the current location information of the electronic device, and store the current location information in the memory of the secure element.

In an embodiment, the processor is further configured to read, from the one or more beacon messages, one or more beacon coordinates, and determine in real-time, using
25 the one or more distances and the one or more beacon coordinates, the current location information of the electronic device. The processor is configured to store the current location information of the electronic device in the memory of the secure element.

In an embodiment, the processor is configured to determine the current location
30 information as an absolute geographic location in two or three-dimensional space.

In an embodiment, the processor is configured to determine the current location information as a two-dimensional location relative to the beacon devices.

In an embodiment, the processor is further configured to generate a secure identifier of the electronic device, using a cryptographic key stored in the memory of the secure
5 element. The processor is configured to transmit, via the radio communication module, a beacon signal, the beacon signal comprising the secure identifier of the electronic device and/or the current location information of the electronic device.

In an embodiment, the processor is further configured to generate a location information message comprising the one or more distances, the beacon, and/or the current
10 location information. The processor is configured to transmit, using the radio communication module or a wired communication interface, the location information message to an external device.

In an embodiment, the processor is further configured to encrypt the location information message using a first cryptographic key securely stored in a memory of the secure
15 element. The processor is configured to transmit the location information message to a trusted software application of the external device. The trusted software application is configured to decrypt the location information message using a second cryptographic key.

In an embodiment, the processor is further configured to generate the location information message to include a network address of the external device and/or a device
20 identifier uniquely identifying the electronic device. The location information message is configured to be forwarded, via an intermediate device, to the external device according to the network address and/or the device identifier.

In an embodiment, the processor is further configured to receive, via the radio communication module, a secure message comprising a message content and a location indicator.
25 The processor is further configured to decrypt the secure message, using an encryption key stored in the memory. The processor is further configured to determine, using the location indicator and the current location information of the electronic device, whether the electronic device is located at the location indicator, and transmit, if the electronic device is positively determined to be at the location indicator, the message content to the
30 external device.

In an embodiment, the secure element further includes a clock and the processor is configured to receive, via the radio communication module, one or more synchronization messages from the one or more beacon devices, and synchronize the clock in the secure element using the synchronization messages.

5 In an embodiment, the processor is configured to determine the one or more distances using a time of arrival of each of the beacon messages.

In an embodiment, the electronic device further comprises a movement sensor and the processor is configured to receive, from the movement sensor, movement data indicating a movement of the electronic location device. The processor is configured to determine the current location information of the electronic location device using the movement data.

In addition to an electronic device, the present disclosure also relates to a mobile phone fitted with a mobile phone case comprising an electronic device as disclosed above.

15 In an embodiment, the mobile phone is configured to provide power to the electronic device via a pluggable connector or magnetic induction.

In addition to an electronic device and a mobile phone, the present disclosure also relates to a device configured to be worn or carried by a user comprising an electronic as disclosed above.

20 Additionally, the present disclosure also relates to a wireless network access point connected to an electronic device as disclosed above, wherein the wireless network access point is configured to provide power to the electronic device via a pluggable connection.

25 Additionally, the present disclosure also relates to a beacon device fixedly installed in or on an object, in particular in a building, comprising an electronic device according as disclosed above, wherein the beacon device is installed at a known location.

BRIEF DESCRIPTION OF THE DRAWINGS

The present disclosure will be explained in more detail, by way of example, with reference to the drawings in which:

- Figure 1: shows a drawing illustrating schematically an electronic device and a plurality of beacon devices according to an embodiment;
- Figure 2: shows a block diagram illustrating schematically an electronic device according to an embodiment;
- 5 Figure 3: shows a block diagram illustrating schematically a plurality of beacon messages;
- Figure 4: shows a flow diagram illustrating schematically a plurality of steps performed by an electronic device according to an embodiment of the invention;
- Figure 5: shows a drawing illustrating schematically an electronic device located within a pre-defined proximity threshold of a beacon device for a pre-defined duration threshold;
- 10 Figure 6: shows a drawing illustrating schematically a mobile phone fitted with a mobile phone case comprising an electronic device according to an embodiment;
- 15 Figure 7: shows a drawing illustrating schematically a smart device configured to be worn or carried by a user comprising an electronic device according to an embodiment;
- Figure 8: shows a drawing illustrating schematically a wireless network access point connected to an electronic device according to an embodiment;
- 20 Figure 9: shows a drawing illustrating schematically a beacon device fixedly installed in or on an object comprising an electronic device according to an embodiment;

DESCRIPTION OF THE EMBODIMENTS

25 **Figure 1** shows a drawing illustrating schematically an electronic device **1** and a plurality of beacon devices **2, 3, 4** according to an embodiment. The electronic device **1** is located inside a building and the beacon devices **2, 3, 4** are fixedly installed in the building, in particular in fixedly mounted to a wall and/or ceiling.

Figure 2 shows a block diagram illustrating schematically an electronic device **1**.
 30 The electronic device **1** includes a secure element **11** and a radio communication module **14**. Depending on the embodiment, the electronic device **1** comprises additional modules,

for example a power module. The power module comprises a battery and/or power receiving means, such as a power socket for receiving electrical power via a wired connection and/or a loop antenna for receiving electrical power via magnetic induction. Depending on the embodiment, the electronic device **1** includes an electronic communication circuit configured for communication via a wired connection, described below in more detail. The secure element **11** refers to specific electronic circuitry in electronic device **1** for securely executing specific computer program code, and as such comprises a memory **13** for storing the code, and a processor **12** for executing the code. The person skilled in the art understands that the secure element **11**, which comprises the memory **13** and the processor **12**, differs from a typical integrated circuit comprising a memory and a processor in a number of ways. Generally speaking, the secure element **11** is configured to store particularly sensitive data and run applications and/or processes securely. Depending on the embodiment, the secure element **11** is configured for tamper resistance or configured to detect tampering, configured to be a root of trust in that it establishes an authentication chain using cryptographic keys stored securely in the memory **13**, configured to provide cryptographically secure random number generation, configured to provide cryptographic services (e.g. AES decrypting using a secret key stored in the memory **13**, generating a signature of a message using a private key stored in the memory **13**, and verifying a signature), configured for secure generation of keys (e.g. generation of a public key pair or of a shared-secret key for authentication), and/or configured to securely monitor further components of the electronic device **1**, such as a hardware or software configuration. The person skilled in the art understands that not all of the previously listed features or services must be present in a secure element circuit **3** according to the present disclosure and that at the same time, mere possession of some of these features or services does not qualify a common processor and memory as being a secure element **11** according to the present disclosure.

The processor **12** of the secure element **11** comprises a central processing unit (CPU) for executing computer program code stored in the memory **13**. The processor **12** also includes more specific processing units such as application specific integrated circuits (ASICs), reprogrammable processing units such as field programmable gate arrays

(FPGAs), or processing units specifically configured to accelerate certain applications, such as cryptographic accelerators for accelerating cryptographic functions.

The memory **13** of the secure element **11** comprises one or more volatile (transitory) and/or non-volatile (non-transitory) storage components. The storage components are non-removable and integrated into the secure element **11**. Examples of storage components include RAM (Random Access Memory), flash memory, data memory, and/or other data stores. In an embodiment, the memory **13** is encrypted and protected from unauthorized access.

The memory **13** has stored therein program code configured to control the processor **12** of the secure element **11**, such that the secure element **11** performs one or more steps and/or functions as described herein. Depending on the embodiment, the program code is compiled or non-compiled program logic and/or machine code.

The memory **13** stores, in general, both computer program code and data. The memory **13** is partitioned into two or more parts, either by physically provisioning the memory **13** as two or more separate hardware modules, or by logically partitioning the memory **13** into two or more logical partitions. The computer program code is configured to control the processor **12** to execute a series of steps and/or functions. In particular, the computer program code comprises application program code and firmware program code. The application program code is configured to control the processor **12** to execute a series of steps and/or functions as described below. The firmware program code is configured to implement an operating system, which operating system includes the application programming interface (API) and operating system functions. The operating system functions comprise a data receiving function in which the processor **12** of the secure element **11** receives data via the radio communication circuit module **14**, and a data transmitting function, in which the processor **12** transmits data via the radio communication module. One skilled in the art is aware that some, depending on the embodiment, some, or even all, of the application program code is contained in the firmware program code, or that vice versa, some or all of the firmware program code is contained in the application program code. Typically, the application program code comprises code specific to a particular embodiment, enabling the electronic device **1** to be flexibly deployed in various technical contexts, as described in below in more detail.

In an embodiment, the firmware program code initially installed and stored in a fixed fashion in the memory **13** of the secure element **11**, during manufacture or commissioning of the electronic device **1**, includes and/or is limited to a basic device boot function for loading and storing securely further firmware program code and/or application program code into the memory **13** of the secure element **11**. Depending on the configuration and/or scenario, the further firmware program code and/or application program code are loaded in one common data file or in separate data files, e.g. in an encrypted data container comprising further firmware program code, in an encrypted data container comprising custom program code, and/or in an encrypted data container comprising further firmware program code and application program code.

The operating system functions further comprise functions to decrypt parts of the received data which are encrypted, as is described below in more detail. The processor **12** uses one or more cryptographic keys stored in the memory **13** of the secure element **11** to decrypt the received data. The cryptographic keys are stored in the memory **13** during manufacture or commissioning of the electronic device **1**.

In an embodiment, the firmware program code further includes one or more cryptographic functions, the one or more cryptographic functions comprising an encryption function, a decryption function, a hash function, a cryptographic key generating function, a cryptographic key deletion function, a cryptographic signing function, and/or a cryptographic signature verification function. In an embodiment, one or more of these functions is implemented as an ASIC in the secure element **11** in order to increase the speed of the secure element **11**.

In an embodiment, the memory **13** has stored therein a known arrangement of the beacon devices **2, 3, 4**. The known arrangement is a spatial arrangement in two or three dimensions. For example, the known arrangement comprises coordinates of the beacon devices **2, 3, 4**, the coordinates being absolute coordinates or relative coordinates.

In an embodiment, the firmware program code is further configured to control the processor **12** of the secure element **11** to implement an error checking function. The error checking function checks whether data received in the secure element **11** was received without error and increases the reliability of the received data. In particular, the firmware program code is configured to implement a cyclic redundancy check function. Other error

checking functions such as a function to check parity bits, checksum functions, cryptographic hash functions, are also implemented, depending on the embodiment. Further, in a variation, the firmware program code is configured to control the processor **12** of the secure element **11** to implement an error correction function.

5 In an embodiment, the operating system functions further comprise a random generator function. The random generator function is configured to control the processor **12** to generate random or pseudo-random numbers.

In an embodiment, the secure element **11** of the integrated circuit **2** further includes a hardware-based random generator. The hardware-based random generator amplifies
10 random thermal noise to generate, using an analog-to-digital converter, a random string of digital bits. The secure element **11**, in particular the operating system functions, comprise cryptographic functions which use the random string of digital bits. These cryptographic functions can also be implemented as application specific circuits of the secure element **11**.

15 In an embodiment, the electronic device **1** is communicatively coupled to one or more additional processors. These additional processors are external to the electronic device **1** and are part of an external device coupled to the electronic device **1**. In some embodiment as described in more detail below, the external device comprises the electronic device **1**. The additional processors are communicatively coupled to the electronic
20 device **1** via a wired connection or via a wireless connection. The wired connection is via a cable or a bus, for example using a UART (Universal Asynchronous Receiver/Transmitter) circuit, using an SPI (Serial Peripheral Interface) communication interface specification, using an I2C (Inter-Integrated Circuit) bus, or using a USB (Universal Serial Bus) communication interface. Depending on the embodiment, the radio communication module
25 **14** is configured for wireless communication by having an RFID (Radio Frequency Identification) radio, more specifically a NFC (Near Field Communication) radio, a Bluetooth radio, a Bluetooth Low Energy radio, and/or an ultra-wideband (UWB) radio. In a preferred variation, the radio communication module **14** is directly connected to the antenna **15**. Specifically, the radio communication module **14** is in direct electrical contact
30 with the antenna **15**, without any intervening circuit elements such as diodes, capacitors, inductors, etc. placed between the radio communication module **14** and the antenna **15**.

All filtering and signal processing takes place in the radio communication module **14**. This allows the electronic device **1** to be manufactured in a smaller space with fewer circuit elements. In an embodiment, the radio communication module **14** is implemented as an analog-to-digital converter and a software-defined radio, which software-defined radio is implemented on a dedicated processor of the radio communication module **14**, or implemented on the processor **12** of the secure element.

In an embodiment, the electronic device **1** further comprises a movement module comprising one or more movement sensors configured to detect a spatial movement of the electronic device **1**. In an example, the movement sensors are accelerometers, such as capacitive accelerometers, and an acceleration measured by the accelerometer is used to determine a spatial movement of the electronic device **1**. In an example, the movement module includes a barometer to measure an atmospheric pressure. The atmospheric pressure is used to determine an elevation and/or a change in height of the electronic device **1**.

Figure 3 shows a block diagram illustrating a plurality of beacon messages **21, 31, 41**. Each beacon message **21, 31, 41** comprises a beacon identifier **22, 32, 42**. The beacon messages **21, 31, 41** are generated and transmitted by the beacon devices **2, 3, 4**. The beacon identifier **22, 32, 42** is a piece of data which uniquely identifies the beacon device **2, 3, 4**, which generated and transmitted the beacon message **21, 31, 41**. In an embodiment, the beacon identifier **22, 32, 42** is a dynamic identifier which changes over time. In particular, the beacon identifier **22, 32, 42** is encrypted using an encryption key.

In an embodiment, the beacon message **21, 31, 41** further comprises beacon coordinates **23, 33, 34** that contain spatial information relating to the precise location, in 2D or 3D space, of the particular beacon device **2, 3, 4**. The beacon coordinates **23, 33, 34** are either fixed coordinates in those embodiments where the beacon devices **2, 3, 4** are fixedly installed, or the beacon coordinates **23, 33, 34** are dynamic coordinates indicating a current location of the beacon devices **2, 3, 4**, in those embodiments where the beacon devices **2, 3, 4** are not fixedly installed and are mobile, for example are carried by or on a person (or a plurality of persons).

In an embodiment, the beacon messages **21, 31, 41** further comprise beacon status indicators **24, 34, 44**, which indicate a beacon device status or a beacon user status. The

beacon device status relates to the hardware and/or software configuration of the beacon device **2, 3, 4**, for example which hardware modules the beacon devices **2, 3, 4** contains, which software and/or firmware is installed on the beacon device **2, 3, 4**, whether the beacon device **2, 3, 4** is fixedly installed or mobile, as is described in relation to Figures **6 – 9** in more detail below. Depending on the embodiment, the beacon device status indicates a transmitting power of the beacon device **2, 3, 4**, a transmitting time of the beacon device **2, 3, 4**, and/or a path loss model identifier. The beacon user status relates to an embodiment in which the beacon device **2, 3, 4** is carried by or on a person. The beacon user status provides information relating to a health status of the person, a group affiliation of the person to a particular group, for example a demographic group or a business group. In an example, the beacon user status indicates whether the person is currently infectious with an infectious disease, whether the person is over an age of **50** years, and/or whether the person has pre-existing medical conditions.

In an embodiment, the beacon message **21, 31, 41** further comprises an encrypted data package, wherein the encrypted data package is configured such that the data package can only be decrypted when the electronic device **1** is located at one or more specific locations. In an embodiment, the one or more specific locations is comprised in the beacon message **21, 31, 41**.

Figure 4 shows a flow diagram illustrating an exemplary sequence of steps according to an embodiment of the invention. In step **S1**, the processor **12** of the secure element **11** obtains one or more beacon messages **21, 31, 41**. The beacon messages **21, 31, 41** are obtained from the radio communication module **14** via the antenna **15**, the beacon messages **21, 31, 41** being received by the radio communication module **14** from beacon devices **2, 3, 4**. In step **S2**, the processor **12** uses the received beacon messages **21, 31, 41** to determine, for each received beacon message **21, 31, 41**, a distance **D1, D2, D3** between the electronic device **1** and each beacon device **2, 3, 4**.

In an embodiment, the Bluetooth low energy radio of the radio communication module **14** determines the distance **D1, D2, D3** between the electronic device **1** using the transmission properties of the beacon message **21, 31, 41**. In particular, the transmission properties comprise a received signal strength of the received beacon message **21, 31, 41** is compared by the radio communication module **14** or the processor **12** to a reference

signal strength that is either a pre-defined reference signal strength stored in the memory **13**, or that is contained in the beacon status indicator **24, 34, 44** of the beacon message **21, 31, 41**. The processor **12** uses a path loss model stored in the memory **13** to determine the distance **D1, D2, D3** using the signal strength, in particular a log-distance path loss model. In an embodiment where the beacon status indicator **24, 34, 44** includes the path loss model identifier, the processor **12** is configured to use the path loss model identifier to select, for use with the path loss model, one of a plurality of path loss models and/or one of a plurality of path loss model coefficients, in particular a log-distance path loss coefficient. This enables the processor **12** to account for a number of different physical environments which affect radio wave transmission, e.g. whether the beacon device **2, 3, 4** is located indoors, outdoor, is fixedly installed in a free-standing manner, is fixedly installed on a wall, or is fixedly installed on a ceiling. Further, the different coefficients are configured to account for different indoor environment types.

In an embodiment, the radio communication module **14** comprises the ultra-wideband radio and is configured to receive and transmit ultra-wideband signals. The ultra-wideband radio is configured to determine distances **D1, D2, D3** between the electronic device **1** and the beacon devices **2, 3, 4**. The electronic device **1** is configured to determine the distance **D1, D2, D3** between a particular beacon device **2, 3, 4** and the electronic device **1** using a time of arrival of the beacon message **21, 31, 41**. The electronic device **1**, in particular the ultra-wideband radio or the processor **12**, is configured to calculate, using the time of arrival, a time of flight and to calculate, from the time of flight, the distance **D1, D2, D3**. In an embodiment, the time of flight is calculated by using the time of transmission as indicated in the beacon message **21, 31, 41**. This requires a clock in the electronic device **1** to be synchronized with the clock in the beacon device **2, 3, 4**. In another embodiment, the time of flight is calculated on the basis of a round trip time. The round trip time is calculated by performing a round trip communication, in which the beacon message **2, 3, 4** is transmitted in response to a signal of the electronic device **1**, or wherein the electronic device **1** is configured to transmit an additional query signal to the beacon device **2, 3, 4**, and receive a response signal from the beacon device **2, 3, 4**, subsequent to receiving the beacon message **2, 3, 4**.

The distance **D1**, **D2**, **D3** to each beacon device **2**, **3**, **4** is stored, in step **S3**, in the memory **13** of the radio communication module **14**. The electronic device **1** is configured to perform the distance determination as well as the storing of the distances **D1**, **D2**, **D3** as current location information in the secure element **11**, ensuring a high level of security.

5 Depending on the embodiment, current location information refers to information relating to the location of the electronic device **1**, and includes both relative location information, such as the distances **D1**, **D2**, **D3** to beacon devices **2**, **3**, **4**. Depending on the embodiment, current location information also relates to a relative or absolute geographic location of the electronic device **1**, as defined by a tuple in relation to a set of geographic or
10 spatial coordinates.

In an embodiment, the processor **12** is configured to transmit the current location information, using the radio communication module **14** or other communication means, from the electronic device **1** to the external device.

In an embodiment, transmitting the current location information comprises transmit-
15 ting current location information for a plurality of time-points in the past. In an embodiment, additional information received from the beacon devices **2**, **3**, **4** is also transmitted along with, or instead of, the current location information, including beacon identifiers **22**, **32**, **42**, beacon coordinates **23**, **33**, **43**, and/or beacon status indicators **24**, **34**, **44**.

In an embodiment, the processor **12** of the electronic device **1** is configured to store
20 only those distances **D1**, **D2**, **D3** which correspond to beacon messages **21**, **31**, **41** received from particular beacon devices **2**, **3**, **4**. In particular, each the processor **21** uses the beacon status indicator **24**, **34**, **44** contained in each beacon message **21**, **31**, **41** along with one or more filter parameters to determine whether the beacon message **21**, **31**, **41**, the distance **D1**, **D2**, **D4**, or any other data contained in or derived using the bea-
25 con message **21**, **31**, **41**, is to be stored in the memory **13**. The processor **12** is configured to use the filter parameters, which filter parameters include all parameters included in the beacon status indicators **24**, **34**, **44**, to determine whether the distances **D1**, **D2**, **D3** and any other data contained in or determined using the beacon messages **21**, **31**, **41**, is to be stored in the memory **13** or not. In an example, in addition to the filter parameters the
30 processor **12** is configured to use the beacon signal strength to determine whether to store the distance **D1**, **D2**, **D3**, the beacon identifier **22**, **32**, **42**, and/or any further data

contained in or derived from the beacon message **21, 31, 41**, associated with a particular beacon device **2, 3, 4**.

In an embodiment, the filter parameters are pre-defined and stored in the memory **13**.

5 In an embodiment, the filter parameters are set dynamically. The processor **12** is configured to adapt the filter parameters according to a set of filter rules stored in the memory **13**. The filter rules define locations and/or times during which the filter parameters are adapted.

10 In an embodiment, the processor **12** is configured to use the distances **D1, D2, D3** along with the known arrangement of beacon devices **2, 3, 4** to securely determine the current location of the electronic device **1**. The current location is the relative or absolute position of the electronic device in two or three-dimensional space. The known arrangement of beacon devices **2, 3, 4** is either retrieved from memory **13** or generated using the beacon coordinates **23, 33, 43** received in the beacon messages **21, 31, 41**. The current
15 location is stored, along with the current time, in the memory **13**.

In an embodiment, the processor **12** is configured to receive, from the movement sensor, movement data relating to a movement of the electronic device **1**, and determine the current location information of the electronic device **1** using the movement data along with the distances **D1, D2, D3**.

20 In an embodiment, the processor **12** is configured to generate a location information message. The location information message comprises the current location information. In an embodiment, the location information message further comprises at least one beacon identifier **22, 32, 42** received in at least one beacon message **21, 31, 41**. In an embodiment, the location information message comprises the distances **D1, D2, D3**. In an
25 example, the location information message comprises not only the current location information, but also current location information for time-points in the past. The processor **12** is configured to transmit the location information message, via the radio communication module **14** or the wired connection, to the external device, in particular to a trusted software application running on the external device.

30 In an embodiment, the location information message is secured through encryption. This ensures that the location information cannot be read if intercepted by a third party

device and/or third party application. The processor **12** is configured to encrypt the location information message using a first cryptographic key stored in the memory **13**. The location information message is encrypted such that the trusted software application is able to decrypt the location information message using a second cryptographic key.

5 In an embodiment, the location information message is transmitted to the external device via an intermediate device. The external device is, in an embodiment, a back-end server system. The location information message is configured by the processor **12** to include a network address of the external device and/or a device identifier uniquely identifying the electronic device **1**. The intermediate device is, in an embodiment, a user device such as a mobile phone, or a gateway device such as a network access point. The location information message is configured such that the intermediate device either requires no pre-defined network address to forward the location information message to, or such that the intermediate device performs a look-up of the network address using the device identifier.

15 In an embodiment, the electronic device **1**, in particular the processor **12**, receives a location request. The location request is received from the external device. The processor **12** is configured to transmit, in response to receiving the location request, the location information message. In an embodiment, the location request comprises credentials. The credentials are used by the processor **12** to determine whether the location request is authentic and/or authorized. The processor **12** is configured to transmit the location information message contingent on a positive determination of whether the location request is authentic and/or authorized.

25 In an embodiment, the electronic device **1** is configured to unlock messages based on the current location information. The electronic device receives, via the radio communication module **14** or the wired connection, a secure message, for example from the external device. The secure message comprises a message content and a location indicator. The secure message is decrypted by the processor **12** using an encryption key stored in the memory **13**. The processor **12** then verifies if the location indicator matches the current location information of the electronic device **1**. If the location indicator matches the current location information of the electronic device **1**, the message content is transmitted, via the radio communication module **14** or the wired connection, to the external

device. Depending on the embodiment, matching the current location information means matching to within a particular tolerance or distance, or being within a certain region. For example, if the secure message contains media content locked to a particular region, the location indicator may indicate a country, and the location indicator matching the current location information requires the current location information to be within the country as indicated by the location indicator. In another example, if the secure message contains access control information, the location indicator indicates a small region at an access control area no larger than a few square meters or indicates a particular point in addition to a matching tolerance. Applications running on the external device, for example trusted applications, can therefore use the electronic device **1** to unlock messages based on securely determined current location information. In an embodiment, in addition to the location indicator, a time indicator is also contained in the secure message, and the processor **12** is configured to transmit the message content to the external device only if the time indicator also matches a current time as provided to the processor **12** by the clock of the electronic device **1**.

In an embodiment, the clock of the electronic device **1** is configured to be adjustable. In one example, the clock of the electronic device **1** is synchronized using a GPS time signal received either directly in a GPS module of the electronic device **1**, or forwarded to the electronic device **1** from the external device, preferably via the direct wired connection. In an embodiment, the processor **12** is configured to perform a decentralized clock synchronization with the beacon devices **2**, **3**, **4**, to ensure accurate determining of the distances D_1 , D_2 , D_3 . The processor **12** is configured to adjust the clock of the secure element **11** according to synchronization messages received via the radio communication module **14** from the beacon devices **2**, **3**, **4**, and to synchronize the clock in the secure element **11** using the synchronization messages received.

In an embodiment, the electronic device **1** is further configured to act as a beacon by emitting a beacon signal. In an environment comprising a plurality of electronic devices **1**, beacon signals emitted by each electronic device **1** enable a location mesh network to form in which each electronic device **1** is configured to determine its own current location information and forward this current location information to surrounding electronic devices **1**. In particular, the processor **12** of the electronic device **1** is configured to generate the

beacon signal comprising a secure identifier of the electronic device **1** and/or the current location information of the electronic device **1**. The secure identifier of the electronic device **1** is generated using a cryptographic key stored in the memory **13** of the secure element **11**. In an embodiment, in addition to the cryptographic key, a random number
5 generated by the random generator function is used by the processor **12** to generate the secure identifier, the random number used then being stored in the memory **13**. The processor **12** is configured to identify whether the secure identifier was generated using the cryptographic key and, in an embodiment, the random number.

Figure 5 shows a drawing illustrating schematically an embodiment where the electronic device **1** and the beacon device **2** move relative each other. The electronic device **1** and/or the beacon device **2** are mobile such that the distance **D1** between the electronic device **1** and the beacon device **2** varies over time. The processor **12** of the secure element **11** of the electronic device **1** is configured to obtain a plurality of beacon messages **21** from the beacon device **2** at a plurality of time points. The distance **D1** is determined
15 by the processor **12** for each of the plurality of time points and stored in the memory **14**. The processor **12** determines whether the distance **D1** is below a pre-defined proximity threshold **PT** for a pre-defined duration threshold **DT**. In particular, the processor **12** checks whether the distance **D1**, across a plurality of time-points corresponding to the pre-defined duration threshold **DT**, is below the pre-defined proximity threshold **PT**. The
20 pre-defined duration threshold **DT** is **30** minutes or more, preferably **15** minutes or more, more preferably **10** minutes or more. The pre-defined proximity threshold **PT** is **10** meters or less, preferably **5** meters or less, more preferably **2** meters or less.

In an embodiment, in addition to determining whether the beacon device **2** is within the pre-defined proximity threshold **PT** for the pre-defined duration threshold **DT**, the processor **12** checks whether the mean of the distance **D1** for a plurality of time-points is
25 within the pre-defined proximity threshold **PT**. In a further embodiment, the processor **12** is configured to check whether the beacon device **2** is within the pre-defined proximity threshold **PT** for a cumulative time period exceeding the pre-defined duration threshold **DT**, wherein time periods of individual instances of the beacon device **2** being within the
30 pre-defined proximity threshold **PT** are summed over a long-term time period, for example one day, more preferably, one hour.

If the beacon device **2** is within the pre-defined proximity threshold **PT** for a pre-defined duration threshold **DT**, the processor **12** is configured to store in the memory **13** the beacon identifier **22** of the beacon device **2**.

In an embodiment, the processor **12** is configured to implement a dynamic proximity threshold **PT** and/or a dynamic duration threshold **DT**. The processor **12** is configured to decrease the proximity threshold **PT** if the electronic device **1** is moving, for example decreasing the proximity threshold **PT** from **5** meters to **2** meters if the electronic device **1** is moving. In an embodiment, the processor **12** is further configured to increase the duration threshold **DT** when the electronic device **1** is moving, for example increasing the duration threshold **DT** from **10** minutes to **15** minutes. When the electronic device **1** is stationary the proximity threshold **PT** and/or the duration threshold **DT** revert to their default pre-defined values. In an embodiment, the processor **12** is configured to implement a dynamic proximity threshold **PT** and/or a dynamic duration threshold **DT** in which the processor **12** checks uses the current location of the electronic device **1** along with a map stored in the memory **13** to determine whether the processor **12** is inside a building and/or an enclosed space. If the processor **12** determines that the electronic device **1** is inside a building and/or an enclosed space the duration threshold **PT** is reduced and the proximity threshold **DT** is increased, for example increasing the proximity threshold **PT** from **5** meters to **10** meters if the electronic device **1** is inside a building or room, and/or decreasing the duration threshold **DT** from **10** minutes to **5** minutes.

Figure 6 shows a block diagram illustrating schematically a mobile phone **5** fitted with a mobile phone case **51** comprising an electronic device **1** as described above. In particular, the electronic device **1** is connected to the mobile phone **5** via a data connection mechanism, for example a wired cable. Alternatively, the electronic device **1** is connected to the mobile phone **5** via a wireless connection, in particular a Bluetooth or NFC connection.

In an embodiment, the electronic device **1** is configured to draw power from the mobile **5** via either a wired connection or by electromagnetic induction via the loop antenna.

The processor **12** of the electronic device **1** is configured to transmit data from the memory **13** to the mobile phone **5**. In particular, the processor **12** of the electronic device

1 is configured to transmit current location information to a secure application running on the mobile phone **5**. The processor **12** of the electronic device **1** is configured to encrypt the current location information and transmit the encrypted current location information to the secure application, ensuring secure transmission of the current location information.

5 In an embodiment, the processor **12** of the electronic device **1** is configured to transmit the encrypted data package to the mobile phone **5**, wherein the encrypted data package is configured such that the data package can only be decrypted when the electronic device **1** is located at one or more specific locations. In particular, the encrypted data package is transmitted by the processor to the trusted software application running on the
10 mobile phone **5** and is configured such that the trusted software application is able to decrypt the data package only when the mobile phone **5** is located at one or more specific locations. Specifically, the encrypted data package is configured such that it is decrypted using the current location information, in particular the current location of the electronic device **1**, transmitted from the electronic device **1** to the mobile phone **5**.

15 **Figure 7** shows a drawing illustrating schematically a smart device **6** configured to be worn or carried by a user comprising an electronic device **1** as described above. The smart device **6** is embodied as a smart watch. Other embodiments of smart devices **6** worn or carried by a user include smart pendants, smart cards, key cards, fobs, smart rings, and other electronic devices which are worn on a person, carried by a person (e.g.
20 attached to a keychain), or carried in a person's possessions (e.g. in a briefcase, handbag, jacket pocket, etc.).

In an embodiment, the smart device **6** provides a HMI (human-machine interface), including such elements as a display, buttons, audio transducer, and/or microphone. The smart device **6** is configured to receive the current location information from the electronic
25 device **1**.

Figure 8 shows a drawing illustrating schematically a wireless network access point **7** connected to an electronic device **1** as described above. The electronic device **1** is either plugged into the wireless network access point **7**, for example using a USB connection, or is integrated into the wireless network access point **7**. The wireless network
30 access point **7** is fixedly installed in or on a building at a known location. The wireless network access point **7** is an access point of a WLAN (wireless local area network).

Figure 9 shows a drawing illustrating schematically a beacon device **8** fixedly installed in or on an object, comprising an electronic device **1** as described above. The beacon device **8** is, in an example, fixedly mounted to a wall at a known location. The electronic device **1** is configured to transmit the known location of the beacon device **8**.

- 5 In particular, the electronic device **1** is configured to transmit absolute coordinates and/or relative coordinates of the known location, either as two dimensional or three dimensional coordinates as part of a periodic signal emitted by the electronic device **1**, specifically by the radio communication module **14**.

EMBODIMENTS IN WHICH AN EXCLUSIVE PROPERTY OR PRIVILEGE IS CLAIMED ARE DEFINED AS FOLLOWS:

5 1. An electronic device for securely determining current location information regarding the electronic device, the electronic device comprising a radio communication module and a secure element including a processor and a memory, the secure element being connected to the radio communication module and the processor being configured to:

10 obtain (S1), from the radio communication module, one or more beacon messages received by the radio communication module from one or more beacon devices,

15 determine (S2) in real-time the current location information, using transmission properties of the one or more beacon messages, the current location information comprising one or more distances (D1, D2, D3) between the electronic device and the beacon devices, and

20 store (S3) the current location information in the memory of the secure element.

2. The electronic device of claim 1, wherein the processor is further configured to:

25 read, from the one or more beacon messages, one or more beacon identifiers, and

30 store a particular beacon identifier in the memory of the secure element, if the distance (D1, D2, D3) to the particular beacon device is below a pre-defined proximity threshold (PT) and if said distance (D1, D2, D3) is maintained for a pre-determined duration threshold (DT).

- 3.** The electronic device of claim **1** or **2**, wherein the processor is further configured to:

5 read, from the one or more beacon messages, one or more beacon status indicators indicating one or more of the following: a beacon device status or a beacon user status, indicative of a status of a user associated with the beacon,

10 filter a particular beacon message, from the one or more beacon messages, using a filter parameter and one or more of: beacon status indicators or a beacon signal strength, wherein the filter parameter is a dynamically set filter parameter,

15 determine in real-time filtered current location information, using transmission properties of the particular beacon message, and

store filtered current location information in the memory of the secure element.

- 20 **4.** The electronic device of any one of claims **1** to **3**, wherein the radio communication module comprises an ultra-wideband radio and the processor is configured to:

25 obtain, from the radio communication module, one or more beacon messages received by the ultra-wideband radio from one or more beacon devices.

- 5.** The electronic device of any one of claims **1** to **4**, wherein the processor is configured to determine in real-time the current location information of the electronic device further using a known arrangement of the beacon device.

- 30 **6.** The electronic device of any one of claims **1** to **5**, wherein the processor is configured to:

read, from the one or more beacon messages, one or more beacon coordinates, and

5 determine in real-time the current location information of the electronic device further using the one or more beacon coordinates.

7. The electronic device of any one of claims 1 to 6, wherein the processor is further configured to:

10 generate, using a cryptographic key stored in the memory of the secure element, a secure identifier of the electronic device, and

15 transmit, via the radio communication module, a beacon signal, the beacon signal comprising one or more of: the secure identifier of the electronic device or the current location information of the electronic device.

8. The electronic device of any one of claims 1 to 7, wherein the processor is further configured to:

20 generate a location information message comprising one or more of: the one or more distances (D1, D2, D3), the beacon identifiers, or the current location information, and

25 transmit, using the radio communication module or a wired communication interface, the location information message to an external device.

9. The electronic device of any one of claims 1 to 8, wherein the processor is further configured to encrypt the location information message using a first cryptographic key securely stored in a memory of the secure element, and transmit the location information message to a trusted software application of the external device.

30

5 **10.** The electronic device of any one of claims **1** to **9**, wherein the processor is further configured to generate the location information message to include a network address of the external device and/or a device identifier uniquely identifying the electronic device, the location information message being configured to be forwarded, via an intermediate device, to the external device according to the network address and/or the device identifier.

10 **11.** The electronic device of any one of claims **1** to **10**, wherein the processor is further configured to:

receive, via the radio communication module, a secure message comprising a message content and a location indicator,

15 decrypt, using an encryption key stored in the memory, the secure message,

determine, using the location indicator and the current location information of the electronic device, whether the electronic device is located at the location indicator, and

20 transmit, if the electronic device is positively determined to be at the location indicator, the message content to the external device.

25 **12.** The electronic device of any one of claims **1** to **11**, wherein the secure element further includes a clock and the processor is configured to:

receive, via the radio communication module, one or more synchronization messages from the one or more beacon devices, and

30 synchronize the clock in the secure element using the synchronization messages.

13. The electronic device of any one of claims **1** to **12**, further comprising a movement sensor and wherein the processor is configured to:

5 receive, from the movement sensor, movement data indicating a movement of the electronic device, and

 determine the current location information of the electronic device using the movement data.

10

14. A mobile phone fitted with a mobile phone case comprising an electronic device according to any one of claims **1** to **13**.

15. A wireless network access point connected to an electronic device according to
15 any one of claims **1** to **13**, wherein the wireless network access point is configured to provide power to the electronic device via a pluggable connection.

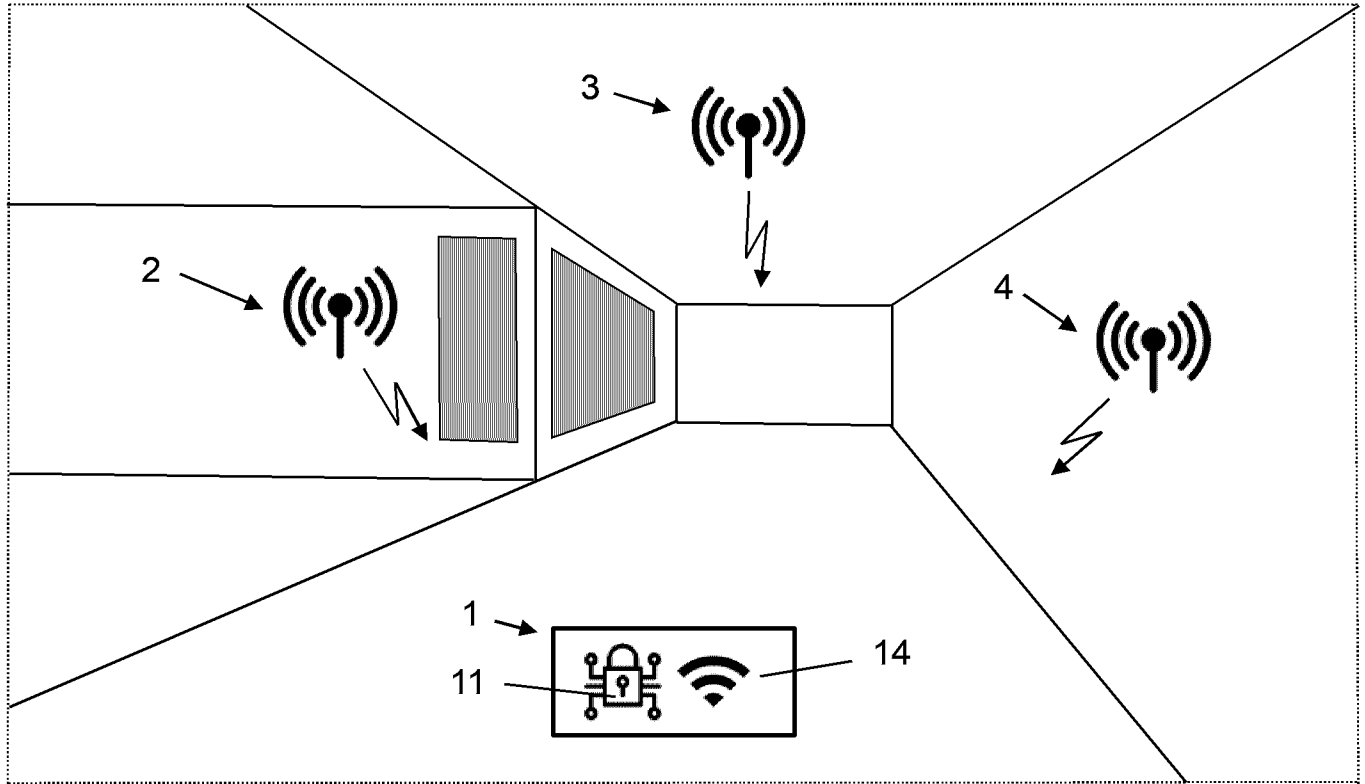

Fig. 1

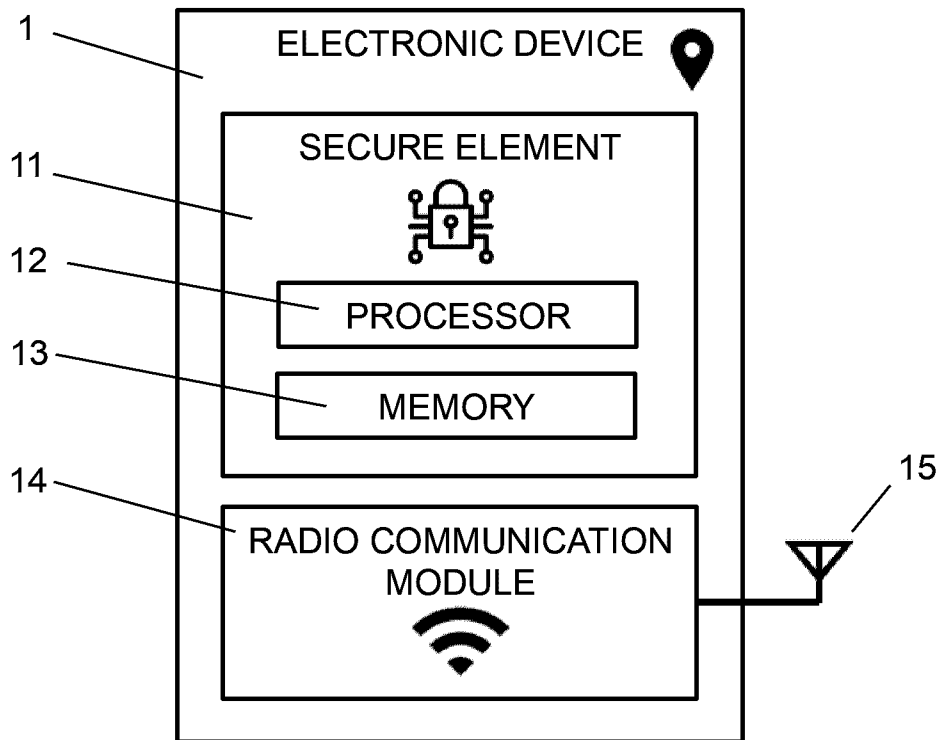

Fig. 2

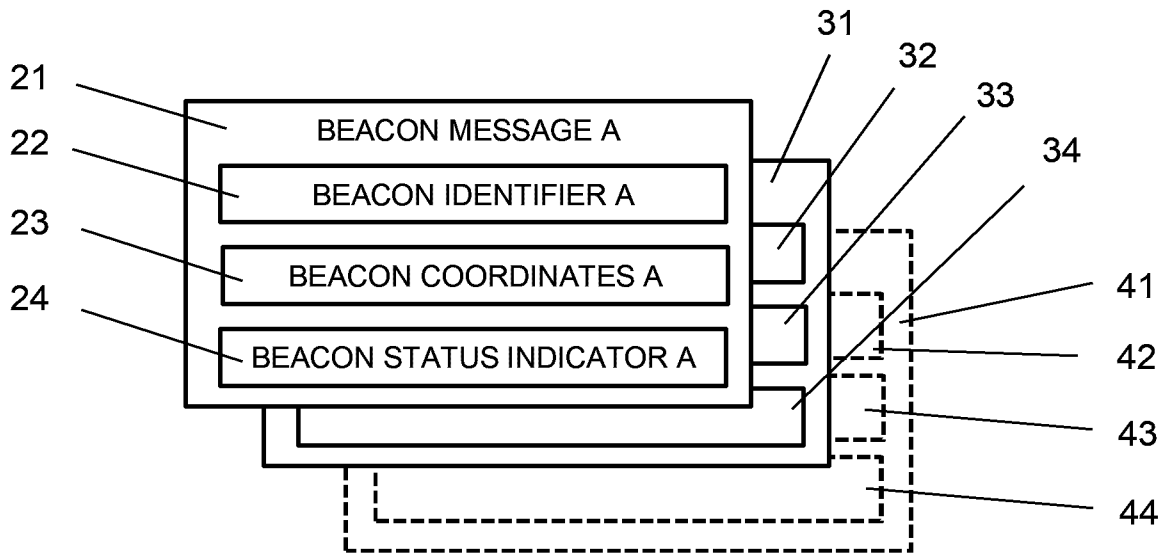

Fig. 3

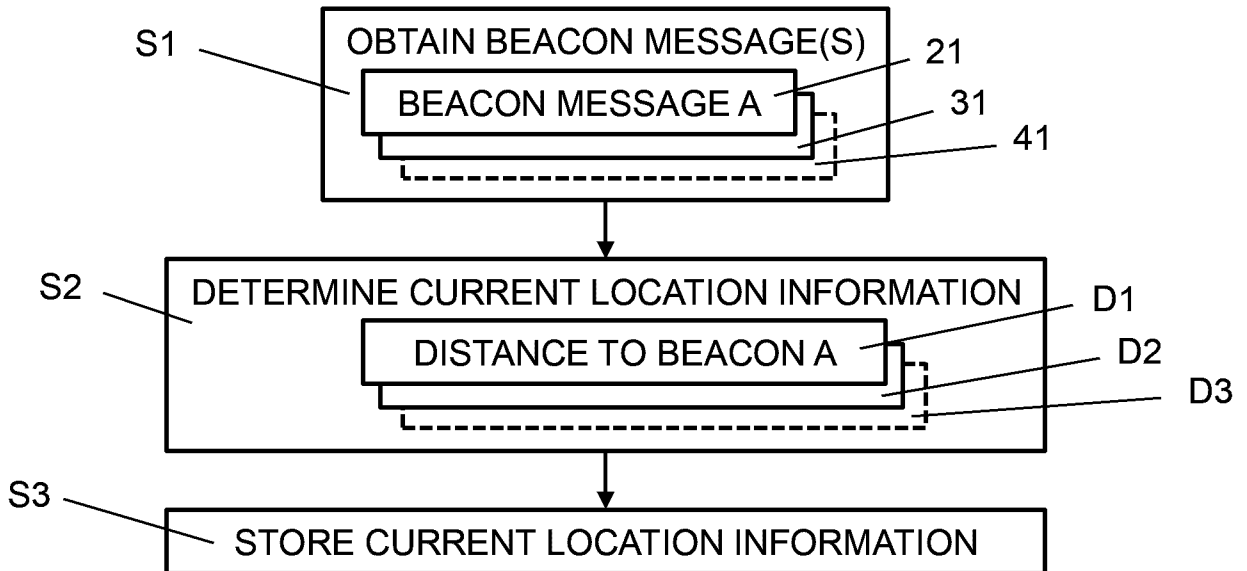

Fig. 4

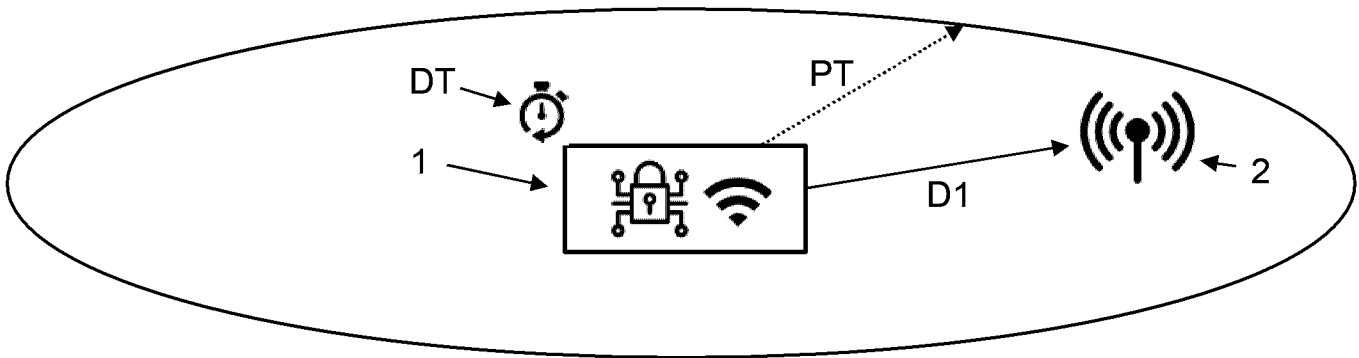

Fig. 5

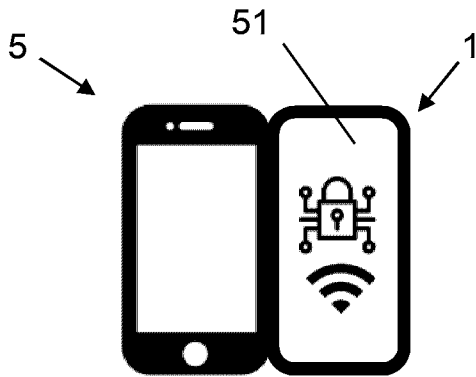

Fig. 6

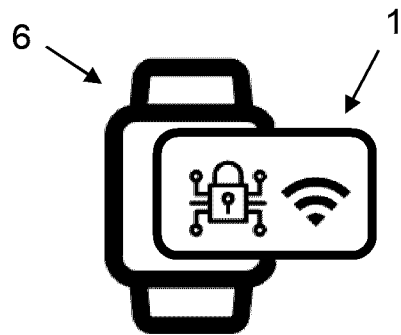

Fig. 7

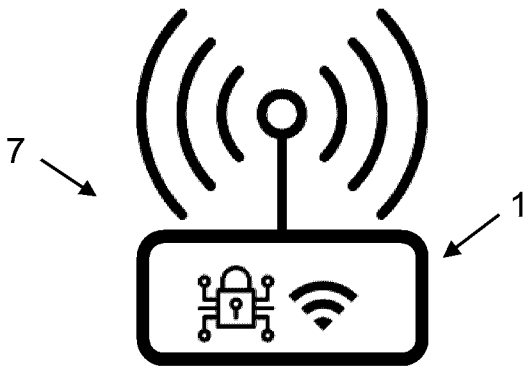

Fig. 8

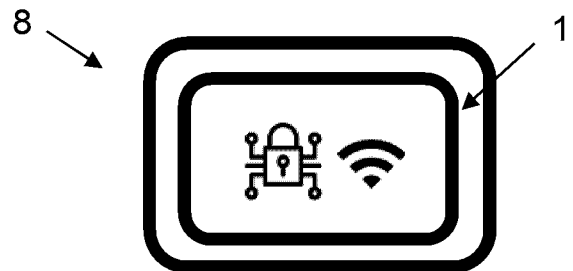

Fig. 9

