



- (51) International Patent Classification:  
B65D 51/16 (2006.01)
- (21) International Application Number:  
PCT/US2010/020631
- (22) International Filing Date:  
11 January 2010 (11.01.2010)
- (25) Filing Language: English
- (26) Publication Language: English
- (30) Priority Data:  
61/204,756 9 January 2009 (09.01.2009) US  
61/245,166 23 September 2009 (23.09.2009) US
- (71) Applicant (for all designated States except US): POREX CORPORATION [US/US]; 500 Bohannon Road, Fairburn, Georgia 30213 (US).
- (72) Inventors; and
- (75) Inventors/Applicants (for US only): KAUCIC, Edward M. [US/US]; 38 Windsor Road, Newnan, Georgia 30263

(US). WINGO, James P. [US/US]; 116 Windalier Ridge, Peachtree City, Georgia 30269 (US). THOMPSON, Bryan [US/US]; 10 First Manassas Way W., Sharpsburg, Georgia 30277 (US). WAGHORN, Trevor [GB/US]; 432 Blue Smoke Trail, Peachtree City, Georgia 30269 (US). CUSHING, Yuet-Yuen Chan [US/US]; 140 Howard Street, NE, Atlanta, Georgia 30317 (US). MEREDITH, Tim [US/US]; 102 Merrywood Lane, Peachtree City, Georgia 30269 (US). FLATER, Michael John [US/US]; 1216 Grand View Drive, Mableton, Georgia 30126 (US). MARTIN, Timothy Allen [US/US]; 235 White Oak Drive, Newnan, Georgia 30265 (US). MAO, Guoqiang [US/US]; 4951 Durley Walk, Smyrna, Georgia 30082 (US).

- (74) Agents: PRATT, John et al.; 1100 Peachtree Street, NE, Suite 2800, Atlanta, Georgia 30309 (US).
- (81) Designated States (unless otherwise indicated, for every kind of national protection available): AE, AG, AL, AM, AO, AT, AU, AZ, BA, BB, BG, BH, BR, BW, BY, BZ, CA, CH, CL, CN, CO, CR, CU, CZ, DE, DK, DM, DO,

[Continued on next page]

(54) Title: RELIEF VENT FOR A HOT FILL FLUID CONTAINER

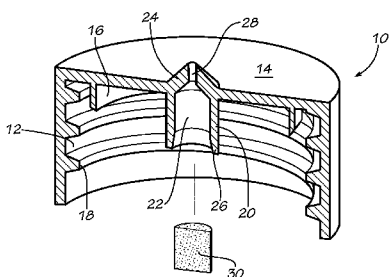


FIG. 1A

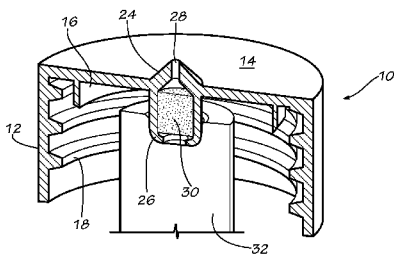


FIG. 1B

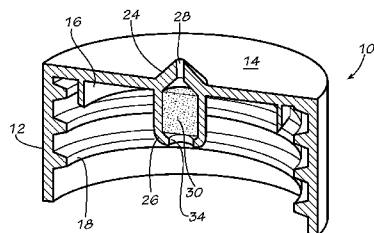


FIG. 1C

(57) Abstract: Caps having porous elements that act as a vent to facilitate cooling of hot fluids stored in containers. Certain embodiments comprise a cap that may be affixed to a container filled with a hot fluid. The cap may include a porous element that allows air to enter the container during the cooling process, but also prevents the introduction of microbes and bacteria into the container. The cap may include a through hole, chamber, or recessed area to receive and secure the porous element. In certain embodiments the porous element may comprise a sintered composite material with thermoplastic particles and either metal particles and/or metal powder. In other embodiments, the porous element may comprise a layered structure. The layers may include a combination of the sintered composite material, a metallic layer, or various porous layers.



DZ, EC, EE, EG, ES, FI, GB, GD, GE, GH, GM, GT, HN, HR, HU, ID, IL, IN, IS, JP, KE, KG, KM, KN, KP, KR, KZ, LA, LC, LK, LR, LS, LT, LU, LY, MA, MD, ME, MG, MK, MN, MW, MX, MY, MZ, NA, NG, NI, NO, NZ, OM, PE, PG, PH, PL, PT, RO, RS, RU, SC, SD, SE, SG, SK, SL, SM, ST, SV, SY, TH, TJ, TM, TN, TR, TT, TZ, UA, UG, US, UZ, VC, VN, ZA, ZM, ZW.

ZW), Eurasian (AM, AZ, BY, KG, KZ, MD, RU, TJ, TM), European (AT, BE, BG, CH, CY, CZ, DE, DK, EE, ES, FI, FR, GB, GR, HR, HU, IE, IS, IT, LT, LU, LV, MC, MK, MT, NL, NO, PL, PT, RO, SE, SI, SK, SM, TR), OAPI (BF, BJ, CF, CG, CI, CM, GA, GN, GQ, GW, ML, MR, NE, SN, TD, TG).

**(84) Designated States** (unless otherwise indicated, for every kind of regional protection available): ARIPO (BW, GH, GM, KE, LS, MW, MZ, NA, SD, SL, SZ, TZ, UG, ZM,

**Published:**

— without international search report and to be republished upon receipt of that report (Rule 48.2(g))

## RELIEF VENT FOR A HOT FILL FLUID CONTAINER

## CROSS-REFERENCE TO RELATED APPLICATIONS

This application claims priority to U.S. Provisional Patent Application Serial No. 5 61/245,166, entitled "Relief vent for a hot fill beverage container," filed on September 23, 2009, and to U.S. Provisional Patent Application Serial No. 61/204,756, entitled "Relief vent for a hot fill beverage container," filed on January 9, 2009, the entire contents of which are incorporated by reference.

## FIELD OF THE INVENTION

10 Embodiments of the present invention relate to vents and/or barriers for fluid containers, for example beverage containers.

## BACKGROUND OF THE INVENTION

When a container is filled with some type of hot fluid and the fluid cools, any gas that is inside the container contracts. This contraction of internal gasses causes a pressure differential 15 between the inside of the container and outside of the container (the ambient conditions), which may cause the sidewalls of the container to collapse inward. The food processing industry is one example of an industry that might encounter such problems. For example, in order to maintain product quality and consumer safety, most foodstuffs are packaged in a hot-fill operation in which the foodstuffs are placed in the containers while hot (for example 82° C or higher), and 20 then a cap is affixed to the container. But such caps seal the contents of the container to ambient conditions. Thus, when the foodstuffs cool, air cannot enter the container to alleviate the pressure differential, and the sidewalls of the container may collapse. It should be understood that the food industry is but one non-limiting example, and other industries may also experience problems with allowing containers to cool.

25 One solution is to provide collapsing panels (or vacuum panels) in the sidewalls to alleviate the pressure differential, but such panels have disadvantages. For example, containers must have thick sidewalls to accommodate panels, which increases material cost and assembly cost. Additionally, the panels may allow the fluid to leak out of the container and may allow airborne microbes to enter the container.

30 Another solution is to provide an aperture in one or both of the container or cap, and to provide a hydrophobic membranes to cover the aperture. A hydrophobic membrane is one that

allows air but not liquid to pass. Although such membranes may relieve the pressure differential, but they are typically very thin (for example 100 microns) and very delicate, and thus may become damaged during the manufacturing or cooling process. The membranes increase manufacturing costs because lamination and/or adhesives are required to secure the membranes.

5           Thus, there is a need for a structure that can more effectively ventilate containers filled with hot fluid.

There is a need for a structure to allow ambient air to enter containers filled with hot fluids to equalize pressures during the cooling process, thus preventing the sidewalls of the container from collapsing.

10           There is a need for a structure that ventilates containers filled with hot fluids while blocking liquid flow out of the container.

There is a need for a structure that ventilates containers filled with hot fluids without causing the introduction of airborne microbes and bacteria into the container.

15           There is a need for a sturdy structure that ventilates containers that will not become damaged during the manufacturing or cooling process.

There is a need to reduce the material cost and assembly cost of such containers for hot fluids.

## SUMMARY OF THE INVENTION

20           Certain embodiments of the invention comprise a cap that may be affixed to a container that is preferably at least partially filled with a hot fluid. For example, in the food processing industry, containers may be filled with hot foodstuffs or fluids, and it may be desirable to allow the containers to cool using embodiments of the invention. The cap may include a porous element that facilitates cooling of the hot fluid. Specifically, the porous element may allow air to enter the container during the cooling process, thus equalizing pressure on either side of the  
25           container walls and preventing or minimizing the sidewalls of the container from collapsing. The porous element may also preferably prevent the introduction of microbes and bacteria into the container. The porous element may be secured to the cap in any number of ways. For example, the cap may include a through hole, chamber, or recessed area to receive the porous element. The porous element may be provided in any desired shape. The porous element is stronger than  
30           previously used membranes and less susceptible to damage. Additionally, in certain

embodiments it is not necessary to use adhesive or lamination to secure the porous element to the cap, thus reducing manufacturing time and expenses.

5 According to certain embodiments the porous element may comprise a sintered porous plastic. In other embodiments, the porous element may comprise a sintered composite material with sintered porous plastic and either metal particles and/or metal powder. In still other  
embodiments, the porous element may comprise a layered structure with at least one porous plastic layer and at least one metallic layer.

10 Regardless of the composition of the porous element, in certain embodiments the porous element contains pores that allow for the passage of air into and out of the container during the cooling process, but that also prevent the passage of microbes and bacteria. Upon sufficient cooling, heat may be applied to the porous element if desired, thus sealing the porous element and the cap.

#### BRIEF DESCRIPTION OF THE FIGURES

15 FIGS. 1A-C are perspective cross-sectional views of one embodiment of a cap having a porous element.

FIGS. 2A-C are perspective cross-sectional views of another cap having a porous element. FIG. 2D is a detailed view of FIG. 2C. FIG. 2E is a perspective cross-sectional view of an alternative embodiment for the cap and porous element shown in FIGS. 2A-2D.

20 FIGS. 3A and 3B are perspective cross-sectional views of another cap having a porous element.

FIGS. 4A-C are perspective cross-sectional views of yet another embodiment of a cap having a porous element.

FIG. 5 is a perspective cross-sectional view of one embodiment of sealing a cap having a porous element.

25 FIG. 6A is a cross-sectional view of another embodiment of a cap having a porous element, wherein the porous element is in the shape of a plug. FIG. 6B is a perspective view of the porous element shown in FIG. 6A.

30 FIG. 7A is a perspective view of an insert containing a porous element for use in caps. FIGS. 7B and 7C are cross-sectional perspective views of the insert (shown in FIG. 7A) affixed to a cap.

FIG. 8 is a microscopic view of one embodiment of a sintered porous plastic.

FIG. 9A is a microscopic view of one embodiment of a sintered composite material. FIG. 9B is a microscopic view showing another embodiment of a sintered composite material.

FIGS. 10A and 10B are both microscopic views of certain embodiments of a first layered structure, comprising a layer of sintered composite material and a layer of sintered porous plastic.

FIG. 11 shows an embodiment of a second layered structure, comprising a porous layer and a metallic layer.

FIG. 12 shows an embodiment of a third layered structure, comprising at least two porous layers and a metallic layer there between.

FIG. 13 shows certain embodiments for manufacturing the layered structures described herein.

FIGS. 14 and 15 show an exemplary cap having a porous element affixed to a container.

#### DETAILED DESCRIPTION

According to certain embodiments of the invention, caps are provided with porous elements that function as a vent to allow air to pass into or out of a container during the cooling process, and also act as a bacterial barrier to prevent microbial and bacterial contamination. FIG. 14 shows one embodiment of a container 160 fitted with cap 80. Container 160 has a neck, where the neck has an external thread. The container 160 may preferably be filled with a hot fluid 162. "Fluid" may include any liquid, gas, and may also include some solid substances (particularly including foodstuffs). All the caps described herein may be secured to the container 160 in the same manner as shown in FIG. 14. Thus, unless otherwise indicated, the caps may include sidewalls 12 having threads 18 to mate with corresponding threads on the neck of the container 160, forming a screw top seal. The caps may optionally include a brim 16 that may fit inside the neck of the container 160 to provide additional protection against the fluid inside the container from leaking.

The embodiment of cap 10 shown in FIG. 1 includes a chamber 22 defined by chamber sidewalls 20. The chamber 22 may be any desired height or width, and may have any desired shape. In its initial state, the chamber 22 has two openings—a bottom end 26 and a through hole 28. The through hole 28 is defined by a protrusion 24 on the outer surface 14 of the cap 10. The bottom end 26 extends downward into the cap 10, and is dimensioned to receive a porous element 30. As shown in FIG. 1A, the porous element 30 may be inserted into the chamber 22 through

the bottom end 26. If desired, a porous element 30 may be selected with dimensions that closely conform to the side walls of the chamber 22 such that a friction fit is formed between the porous element 30 and the chamber 22. As shown in FIG. 1B, after the porous element 30 is inserted, a tool 32 may be used to crimp the chamber sidewalls 20 to secure the porous element 30 within the chamber 22. If desired, the bottom end 26 may be chamfered to facilitate crimping of the chamber sidewalls 20. As shown in FIG. 1C, the chamber sidewalls 20 need not be fully closed or crimped together. Rather, there may still be an opening 34 after the crimping step to facilitate the cooling process and the flow of air into the container.

In other embodiments, the cap 40 in FIG. 2A-E includes a recessed area 42 that is dimensioned to receive a porous element 46 that is disc-shaped. The particular size and shape of the recessed area 42 is not essential, provided that it can receive the porous element 46. In certain embodiments the outer edges of the recessed area 42 are defined by a lip 44. As shown in FIG. 2B, a tool 32 may be used to crimp down the lip 44 over the porous element 46, securely holding the porous element 46 in place. FIGS. 2C and D show the completed cap 40 with a crimped lip 44. A slightly modified version of cap 40 is shown in FIG. 2E. Rather than having a lip 44, certain embodiments may have a plurality of tabs 48 that extend over the porous element 46. Thus, it should be understood that there are multiple ways to secure the porous element 46 to the cap 40—some embodiments may include lip 44, others a plurality of tabs 48, and still others may have other members to secure the porous element 46 to the cap 40.

According to certain embodiments, such as cap 50 shown in FIG. 3, a protrusion 24 may define a through hole having a wide portion 52 and a narrow portion 54. The porous element 56 may be press fitted into the wide portion 52 to form a friction fit to secure the porous element 56 into the wide portion 52.

In yet other embodiments, such as those shown in FIGS. 4A-B, cap 60 is provided with a laminated structure 62 that comprises at least one porous element 64 and at least one substrate 66. Non-limiting examples for the substrate 66 may include polyethylene (PE) or polypropylene (PP). There may be an aperture 68 in the substrate 66 that exposes the porous element 64, thus providing a passage for air to flow into the through hole 28 and through the porous element 64. The porous element 64 may be laminated, welded, adhered to, or otherwise attached to the substrate 66. In some embodiments the laminated structure 62 may be inserted into the cap 60 such that the porous element 64 contacts the inner surface 61 of the cap 60. But in other embodiments the laminated structure 62 may be flipped such that the substrate 66 contacts the inner surface 61. In either configuration, the porous element 64 is generally positioned over the

through hole 28. A slightly modified version of cap 60 is shown in FIG. 4C. Rather than having a laminated structure 62 with a substrate 66, certain embodiments may have an extended porous element 67 that is dimensioned to cover substantially all of the inner surface 61 of the cap 60.

In certain other embodiments there may be provided a plug-shaped porous element 82, such as shown in FIGS. 6A and 6B. The head 84 may sit above the outer surface 14 of the cap 80, and the body 86 may be inserted into the through hole 28. If desired, the head 84 may be color-matched to the outer surface 14 of the cap 80, have a logo or design, or otherwise the head 84 may be aesthetically pleasing. The plug-shaped porous element 82 may be formed by molding, or by machining other porous elements (such as the cylindrically-shaped porous elements 30, 56). As described more thoroughly herein, in certain embodiments the plug-shaped porous element 82 may comprise a layered structure. In one specific and non-limiting example, a plug-shaped porous element 82 was formed from polyethylene, and the element 82 had a height of 5 mm. The pore size in this specific example was approximately 14  $\mu\text{m}$ . The plug-shaped porous element 82 was found to have a bacterial filtration efficiency of over 99.9% based on the ASTM 1200 test, and an air flow of 9 liters per minute. The same bacterial filtration efficiency and air flow rate was achieved in another non-limiting example, where the porous element 82 was made of ultra high molecular weight polyethylene (UHMWPE) and the pore size was approximately 7-10  $\mu\text{m}$ .

Although the embodiments have been described as having separate caps and porous elements that are subsequently assembled together, it should be understood that in certain embodiments the porous elements may be manufactured into the caps by insertion molding. For example, in FIG. 1, porous element 30 may be insertion molded into the chamber 22. In FIG. 2, the porous element 46 may be insertion molded into the recessed area 42 and in FIG. 3, the porous element 56 may be injection molded into the wide portion 52.

Once the porous element is secured within the cap, the cap may be affixed to the container, as shown in FIG. 14. Although FIG. 14 shows a plug-shaped porous element 82, it should be understood that all the caps described herein may be secured to the container 160 in the same manner. As the hot fluid 162 within the container 160 cools, any gas inside the container 160 may contract and result in lower pressure inside the container 160 than outside. Air moves from areas of high pressure (outside the container 160) to areas of low pressure (inside the container 160), and thus, air may flow into through hole 28, pass through porous element 82, and into the container 160. The flow of air into the container 160 equalizes pressure between the exterior and interior of the container 160 and prevents the sidewalls of the container 160 from

collapsing. Additionally, as described more fully below, the porous element 82 preferably has sufficiently small pores to prevent the passage of any microbial mater into the container 160. In some embodiments, the porous elements described herein have a bacterial filtration efficiency of over 99.9% based on the ASTM 1200 test.

5           When sufficient time for cooling has passed, the cap may be sealed in order to minimize or prohibit any further flow of air into or out of the container. FIG. 5 shows one method for sealing cap 10, where a heating tool 70 is used to heat the protrusion 24, which causes the material to melt. The protrusion 24 will then re-harden to seal the cap 10. This can be accomplished using a variety of techniques, such as spin welding techniques with a forming die,  
10           sonic welding, heat sealing, or any similar procedure. In other embodiments, the porous element itself may be sealed by heating the porous element until it becomes non-porous (also referred to as sealed). For example, in FIG. 15, the plug 82 may be heated (represented by the spirals 164) such that the plug 82 becomes non-porous and seals the cap 80. Yet another technique is to inject a sealant into the through hole 28 and allow the sealant to cure, thus sealing the through hole 28  
15           (not shown).

          Yet another embodiment of a cap 88 having a porous element 96 is shown in FIGS. 7A-C. FIG. 7A shows insert 90, which is generally cylindrical and includes a plurality of side holes 92. A porous element 96 is contained within the insert 90, and is exposed by the side holes 92. If desired, the outer surface 94 of the insert 90 may be non-porous. FIG. 7B shows the insert 90 and  
20           cap 88 in an initial position, where the side holes 92 are above the outer surface 14 of the cap 88 and are exposed to ambient conditions. The cap 88 may be affixed to a container (such as container 160 shown in FIG. 14) and any contents within the container may be allowed to cool. In this initial position, ambient air may enter the side holes 92, go through the porous element 96, and into the container. When sufficient time for cooling has passed, the insert 90 may be pressed  
25           into the cap 88 such that the side holes 92 are no longer exposed to ambient conditions. Thus, in FIG. 7C, the side holes 92 are beneath the inner surface 61 of the cap 88. In embodiments wherein the outer surface 94 of the insert 90 is non-porous, the cap 88 is sealed in this second position. If desired, a wax or sealant may be applied to the outer surfaces 14, 94 in order to further seal the cap 88.

30           According to certain embodiments, the porous elements described herein are sintered and may be made from a variety of materials. Certain materials for the porous elements are described in FIGS. 8-12. But other suitable materials include polytetrafluoroethylene (PTFE), polyethylene, polypropylene, and polyesters. Polyethylene includes high density polyethylene

(HDPE) and ultra high molecular weight polyethylene (UHMWPE). The average pore sizes of porous elements for use in certain embodiments of the invention may be from 0.1 micron to 50 microns. If desired, a porous element may comprise a laminated structure, where the laminated structure comprises a polymer and a substrate and/or a membrane. Examples of substrates include other porous polymers, non-woven or woven fibers, a non-woven or woven sheet or plastic tubes. Examples of membranes include polyvinylidene fluoride (PVDF) membranes, nylon membranes, polyethylene membranes, ultrahigh molecular weight polyethylene micro fiber membranes, polypropylene membranes, polysulfone or polyethersulfone membranes. These membranes generally have pore sizes from 0.1 microns to 5 microns and are available from Millipore Corporation (based in Billerica, Massachusetts), Pall Corporation (based in Port Washington, New York), General Electric Company (based in Fairfield, Connecticut), and Koninklijke DSM N.V. (based in the Netherlands). Other materials that may be used for the porous elements (shown in FIGS. 8-10) will now be described.

FIGS. 8-10 are microscopic views of materials that may be used to make the porous elements described herein. The materials have already been sintered and are in a solid form. Before being sintered, however, the individual particles are loose and have no shape. The particles may be placed into a mold, and the mold (and/or the particles) may be heated to sinter the material into a solid. Despite being sintered, the materials still have pores to allow air to pass through the materials, while at the same time blocking bacteria and microbes. Upon being sintered, the materials may be shaped into any desired porous element and inserted into a cap.

FIG. 8 shows an embodiment of a sintered porous plastic comprised of a plurality of thermoplastic particles. The thermoplastic particles may include any suitable thermoplastic material, including but not limited to polyolefins, polyethylene (PE), low density polyethylene (LDPE), high density polyethylene (HDPE), ultra high molecular weight polyethylene (UHMWPE), polypropylene (PP), ethylene vinyl acetate (EVA) or their copolymers. The pores in the sintered porous plastic allow air to pass through, but at the same time the pores block bacteria and microbes. In specific and non-limiting examples, a collection of four porous elements comprising the sintered porous plastic were formed using polyethylene particles. The porous elements varied in thickness between 1.6 and 3.2 mm. The pore sizes in the porous elements ranged between 10 and 12  $\mu\text{m}$ . Each of the porous elements were found to have a bacterial filtration efficiency of over 99.9% based on the ASTM 1200 test, and an air flow of 28 liters per minute.

FIGS. 9A and 9B illustrate embodiments of a sintered composite material 100. The sintered composite material 100 shown in FIG. 9A comprises thermoplastic particles 102 and metal particles 104, whereas the embodiment shown in FIG. 9B comprises thermoplastic particles 102 and metal powder 106. The thermoplastic particles 102 may be as described in FIG. 8. The metal particles 104 and/or the metal powder 106 may be made of any suitable metal, including but not limited to steel, stainless steel, aluminum, copper, tin, iron, or their alloys. The metal particles 104 shown in FIG. 9A are generally larger than the metal powder 106 shown in FIG. 9B. As a result, the larger metal particles 104 result in a larger pore 108 size than shown in FIG. 9B. It should be understood that the figures are merely exemplary, and that the relative sizes of the pores 108 or the particles 104 and powder 106 are not necessarily to scale. The pores 108 in the sintered composite material 100 allow air to pass through, but at the same time the pores 108 block bacteria and microbes.

FIGS. 10A and 10B illustrate certain embodiments of a first layered structure 120, comprising at least a layer of sintered composite material 100 and a layer of sintered porous plastic 122. Although the boundary lines between the respective layers 100, 122 in FIGS. 8A and 8B are both well-defined, it should be understood that in application, the boundary line may be less defined. The sintered composite material 100 may be as described in either FIG. 9A or 9B, and the sintered porous plastic 122 may be as described in FIG. 8. The first layered structure 120 may be formed in one of several ways. For example, the layers may be formed separately and then joined together, as one of skill in the art would understand. Another possible method is molding. A first portion of a mold cavity may be filled with a mixture containing both thermoplastic particles 102 and either metal particles 104 or metal powder 106 (to form layer 100). A second portion of the cavity may be filled with thermoplastic particles 102 (to form layer 122). The thermoplastic particles 102 within the respective layers may have the same size or shape, and may be composed of the same material, or they may be different.

FIG. 11 illustrates an embodiment of a second layered structure 130 that includes at least a metallic layer 132 and a porous layer 144. The metallic layer 132 may contain some type of perforation 134. For example, the metallic layer 132 may comprise metal mesh, metal foil with holes, or a metal screen, and may be made of steel, stainless steel, aluminum, copper, zinc, tin, iron, or their alloys. The porous layer 144 may comprise sintered porous plastic 122, sintered composite material 100, polymer membranes, polyethylene (PE), polypropylene (PP), polytetrafluoroethylene (PTFE), expanded PTFE (e-PTFE), polyvinylidene fluoride (PVDF), polyethersulfone (PES) or nylon. Although the porous layer 144 may vary depending upon

application, it may be desirable for the porous layer 144 to have relatively small pores 108 to act as a bacterial barrier.

In its initial state, the second layered structure 130 is porous to allow the passage of air. The metallic layer 132 does not obstruct the passage of air due to the perforations 134 in the metallic layer 132. Additionally, the pores 108 in the porous layer 144 are sized to allow air to pass, but also act as a bacterial barrier. In some embodiments, the porous layer 144 has a bacterial filtration efficiency of over 99.9% based on the ASTM 1200 test. Upon sufficient heating, the porous layer 144 may become non-porous. Specifically, the pores 108 in the porous layer 144 may melt, thus sealing the second layered structure 130 and preventing air from entering or exiting the container.

FIG. 12 illustrates an embodiment of a third layered structure 140, which may contain a first porous layer 142, a metallic layer 132, and a second porous layer 144. The metallic layer 132 and the second porous layer 144 may be similar to those described above and depicted in FIG. 11. The first porous layer 142 may be initially porous. Non-limiting examples for the first porous layer 142 include sintered porous plastic 122, sintered composite material 100, polymer screen, polymer non-woven or woven materials, or a polymer open cell foam. Thus, in the initial state of the third layered structure 140, the first and second porous layers 142, 144 both contain pores 108 and the metallic layer 132 contains perforations 134 to allow for the passage of air into or out of the container. Additionally (and as shown in FIG. 12), the second porous layer 144 has smaller pores 108 than the first porous layer 142. Thus, the second porous layer 144 may act as a barrier to prevent microbes and/or bacteria from passing through the third layered structure 140.

Upon sufficient heating the third layered structure 140 may become sealed. Specifically, it may be desirable to provide a first porous layer 142 that melts more readily than the second porous layer 144, so that the first porous layer 142 may become non-porous. Thus, the first porous layer 142 may have a higher melt index, lower melting temperature, and/or a lower viscosity than the second porous layer 144. Materials with a high melt flow index and low viscosity tend to minimize or eliminate any pores 108 that may be formed therein. And if the first porous layer 142 has a lower melting temperature than the second porous layer 144, then it will melt first. Thus, upon sufficient heating the first porous layer 142 may be non-porous to seal the container.

According to certain embodiments, the first porous layer 142 may comprise a colored polymer screen and the metallic layer 132 may comprise a metal screen. Upon heating, the

colored polymer screen and the metal screen melt together to seal the third layered structure 140. In other embodiments, the first porous layer 142 may comprise a colored polymer open-celled foam, the metallic layer 132 may comprise a metal screen, and the second porous layer 144 may comprise a bacterial barrier membrane, which may then be non-contact heated with an air jet to melt the colored polymer open-celled foam and thus seal the third layered structure 140.

Certain methods of making layered structures are illustrated in FIG. 13. The particular method in FIG. 13 may be useful if the layered structures comprise materials that may be rolled onto drums (such as screens, membranes, or woven materials). Thus, drum 150 may supply the first porous layer 142, drum 152 may supply the metallic layer 132, and drum 154 may supply the second porous layer 144. The respective layers are extended off the drums. If desired, an adhesive may be applied between layers so that they adhere together. A tool 156 may be used to punch the layers into the desired shape. The finished layered structure may then be inserted into a cap to serve as a porous element (as in FIGS. 1-7). Although the method in FIG. 13 has three drums (150, 152, 154) and thus pertains to the third layered structure 140, one of ordinary skill in the art would understand how to modify the method to make the second layered structure 130, for example, by not providing the drum 150 that supplies the first porous layer 142. Other modifications to produce other layered structures are also known to one of skill in the art.

In embodiments comprising metal (such as the sintered composite material 100 or any of the layered structures), induction heating may be used to sinter and/or seal the material. Induction heating is generally known to one of skill in the art as a process of heating an electrically conducting object by electromagnetic induction, where a high-frequency alternating current (AC) is generated within the metal and resistance leads to heating of the metal. For example, when the sintered composite material 100 is induction heated, the temperature of the metal particles 104 may increase, because metal is a good conductor. The radiant heat from the metal particles 104 melts the surrounding thermoplastic particles 102. Upon sufficient heating the material may become non-porous, thus sealing the cap.

In certain embodiments, the materials described herein—such as sintered porous plastic 122, sintered composite material 100, and/or the layered structures—may have specific shapes or sizes to facilitate their as porous elements. For example, they may be cylindrically shaped (like porous elements 30 or 56), disc-shaped (like porous elements 46, 64 67), or shaped like the plug 82 shown in FIGS. 6A-6B. In certain embodiments the plug 82 may be formed of a layered structure, such as the layered structures 120, 130, or 140. At least a portion of the head 84 may comprise a material that is initially porous but that becomes non-porous and sealed upon

sufficient heating, and at least a portion of the body 86 may comprise a material that acts as a bacterial barrier. For example, the head 84 may comprise the porous layer 142 or the metallic layer 132 and the body 86 may comprise porous layer 144. Such a layered structure may be formed by molding.

5 Caps having porous elements as described herein may be prone to tampering. For example, if the porous element is exposed or visible then people may tend to pick at the porous element. Such tampering may cause injury to the person and may sacrifice the seal of the cap. Thus, it may be desirable to provide tamper-resistant properties to caps and/or porous elements. In one embodiment, the head 84 of the plug 82 described above may melt to and become fused  
10 with the rest of the cap 80, which reduces tampering. In embodiments having a metallic layer 132, the strength of the metallic layer 132 may make it exceedingly difficult to tamper with the porous element and/or cap. Thus, the sealing and strength of certain embodiments provide tamper-resistant properties.

If desired, any of the layered structures described herein may contain one or more  
15 additional layers. In embodiments where the porous layer 142 is not itself non-porous or sealed, a separate hydrophobic layer may be provided, including but not limited to wax, an adhesive sealant, or polyethylene. Similarly, although in some embodiments the first porous layer 142 and/or the metallic layer 132 may be tamper-resistant, in other embodiments a separate tamper-resistant layer may be provided. Finally, the layered structures may be provided with oxygen  
20 scavenger properties. When air enters the container during the cooling process, a certain amount of air (and oxygen) may remain in the container even after cooling and sealing of the porous element. The remaining oxygen may cause unpleasant properties, such as distaste of the contents in the container. Thus, one or all of the layers in the various layered structures (120, 130, 140) may contain iron powder, which reacts with and eliminates oxygen in the container.

25 The foregoing is provided for purposes of illustration and disclosure of embodiments of the invention. It will be appreciated that those skilled in the art, upon attaining an understanding of the foregoing may readily produce alterations to, variations of, and equivalents to such embodiments. Accordingly, it should be understood that the present disclosure has been presented for purposes of example rather than limitation, and does not preclude inclusion of such  
30 modifications, variations and/or additions to the present subject matter as would be readily apparent to one of ordinary skill in the art.

## CLAIMS

1. A cap for a container, the cap comprising:
  - a. a top surface having an outer edge, a first side, and a second side opposite the first side, wherein the second side faces towards the container;
  - b. at least one sidewall extending from the outer edge of the top surface and towards the second side, wherein the at least one sidewall is at least partially threaded to engage with a neck of the container;
  - c. at least one through hole defined by the top surface and passing between the first side and the second side; and
  - d. a porous element adjacent to the top surface and generally aligned with the through hole, wherein the porous element comprises a plurality of pores that allow air to enter the container but prohibit bacteria from entering the container.
2. The cap as in claim 1, further comprising at least one chamber wall extending from the second side of the top surface of the cap, wherein the chamber wall defines a chamber that receives the porous element.
3. The cap as in claim 1, further comprising at least one chamber wall extending from the first side of the top surface of the cap, wherein the chamber wall defines a chamber that receives the porous element.
4. The cap as in claim 1, wherein the second side of the top surface of the cap defines a recessed area, and the porous element is secured within the recessed area.
5. The cap as in claim 4, further comprising a lip extending around at least a portion of the recessed area, wherein the lip secures the porous element within the recessed area.
6. The cap as in claim 4, wherein the porous element is disc-shaped.

7. The cap as in claim 1, further comprising a protrusion extending from the first side of the top surface of the cap, and wherein the through hole is defined by the protrusion.
8. The cap as in claim 1, further comprising a layered structure comprising the porous element and at least one substrate, wherein the layered structure contacts the second side of the top surface of the cap.
9. The cap as in claim 1, wherein the porous element covers substantially all of the second side of the top surface of the cap.
10. The cap as in claim 1, wherein the porous element has a head and a body, and wherein the body is inserted into the through hole and the head contacts the first side of the top surface of the cap.
11. A device for facilitating the cooling of fluids within a container, the device comprising:
  - a. a cap, the cap comprising:
    - a top surface having an outer edge and at least one sidewall extending from the outer edge of the top surface, wherein the at least one sidewall is at least partially threaded to engage with a neck of the container;
    - at least one through hole defined by the top surface; and
  - b. a porous element adjacent to the top surface and generally aligned with the through hole, the porous element comprising:
    - a metallic layer comprising a plurality of perforations;
    - a porous layer comprising a plurality of pores that allow air to enter the container but prohibit bacteria from entering the container.
12. The device as in claim 11, wherein the porous layer comprises at least one of sintered porous plastic, sintered composite material, porous polyethylene, porous polypropylene,

polytetrafluoroethylene, expanded polytetrafluoroethylene, porous polyvinylidene fluoride, porous polyethersulfone, or porous nylon.

13. The device as in claim 11, wherein the metallic layer comprises at least one of metal mesh, metal foil with holes, or a metal screen.

14. The device as in claim 11, wherein the metallic layer comprises at least one of steel, stainless steel, aluminum, copper, zinc, tin, iron, or their alloys.

15. The device as in claim 11, wherein the porous layer is a second porous layer, and wherein the device further comprises a first porous layer.

16. The device as in claim 15, wherein the first porous layer comprises a material having at least one of a higher melt index, lower melting temperature, and/or a lower viscosity than the material comprising the second porous layer.

17. The device as in claim 15, wherein the first porous layer becomes non-porous after melting.

18. The device as in claim 15, wherein the first porous layer is adjacent to the top surface of the cap, and the metallic layer is positioned between the first porous layer and the second porous layer.

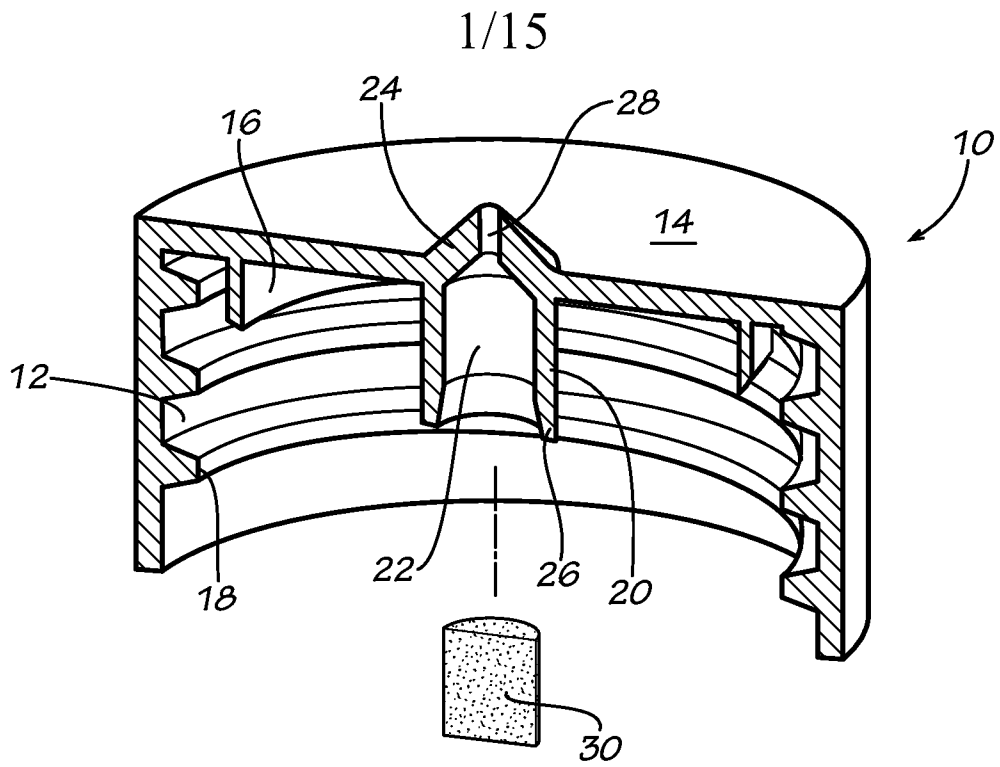
19. The device as in claim 15, wherein the first porous layer comprises at least one of polymer screen, polymer non-woven material, polymer woven material, or a polymer open cell foam.

20. The device as in claim 11, wherein the porous element comprises a head and a body, and wherein at least a portion of the head comprises the metallic layer and at least a portion of the body comprises the porous layer.

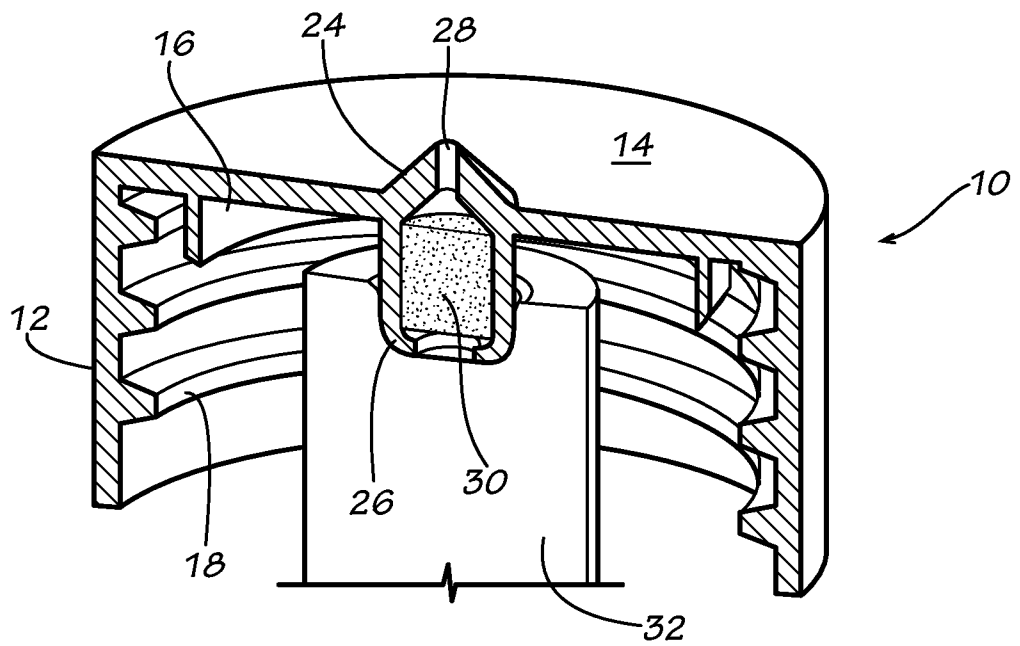
21. A device for facilitating the cooling of fluids within a container, the device comprising:
- a. a cap, the cap comprising:
    - an outer surface having an outer edge and at least one sidewall extending from the outer edge of the outer surface, wherein the at least one sidewall is at least partially threaded to engage with a neck of the container;
    - at least one aperture defined by the outer surface; and
  - b. an insert secured within the aperture of the cap, the insert comprising:
    - an outer surface having an outer edge and at least one sidewall extending from the outer edge of the outer surface, wherein the at least one sidewall defines at least one through hole;
    - a porous element secured within the insert and generally aligned with the through hole, the porous element comprising a plurality of pores that allow air to enter the container but prohibit bacteria from entering the container,

wherein in a first position the through hole of the insert is above the outer surface of the cap, and in a second position the through hole of the insert is below the outer surface of the cap.
22. A method of cooling fluid within a container, the method comprising:
- a. providing a container at least partially filled with fluid;
  - b. providing a device comprising:
    - i. a cap, the cap comprising a top surface having an outer edge and at least one sidewall extending from the outer edge of the top surface, wherein at least a portion of the sidewall comprises structure to engage with a neck of the container, and wherein the top surface defines at least one through hole;
    - ii. a porous element adjacent to the top surface and generally aligned with the through hole, wherein the porous element comprises a plurality of pores that allow air to enter the container but prohibit bacteria from entering the container;
  - c. engaging the device to the neck of the container;
  - d. allowing the fluid to cool, wherein during cooling air enters or exits the container through the porous element; and

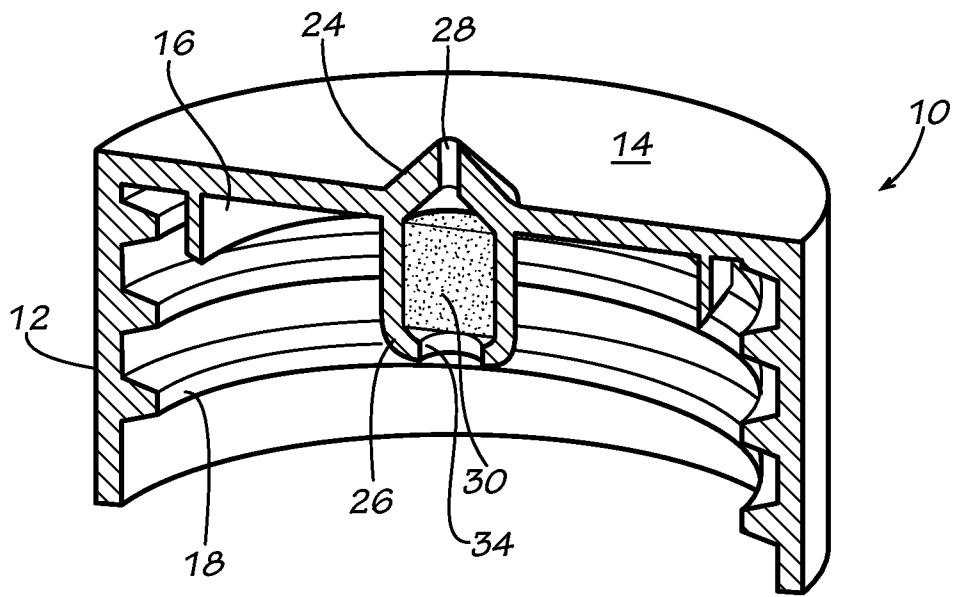
e. applying heat to at least one of the through hole or the porous element to thereby seal the device.



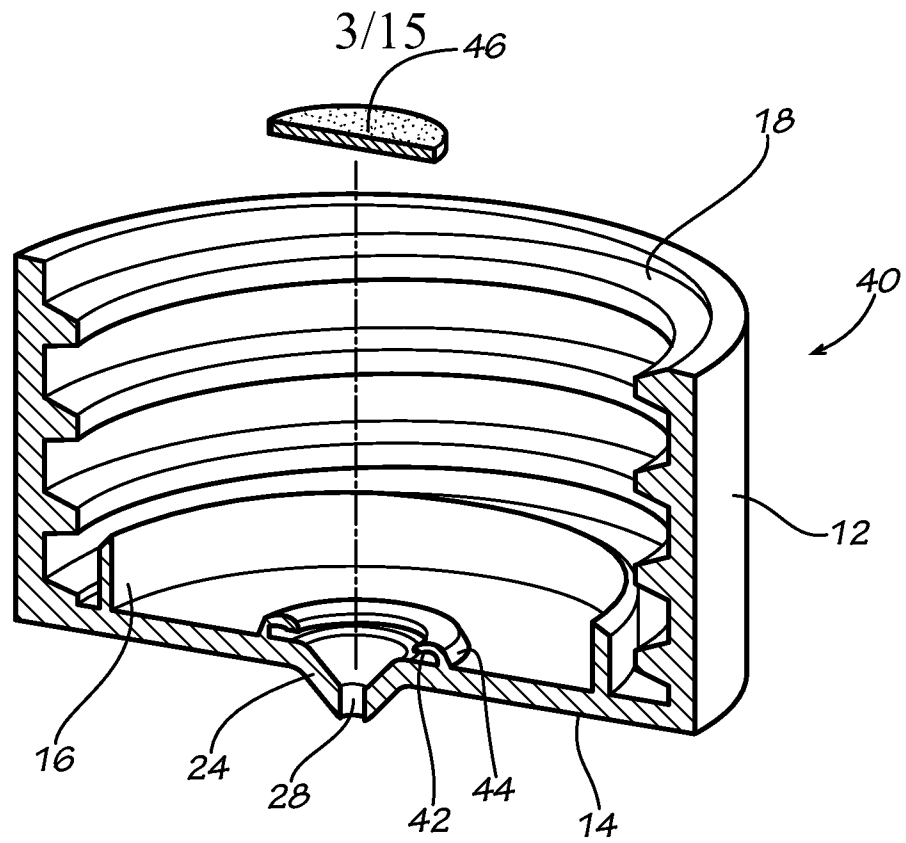
**FIG. 1A**



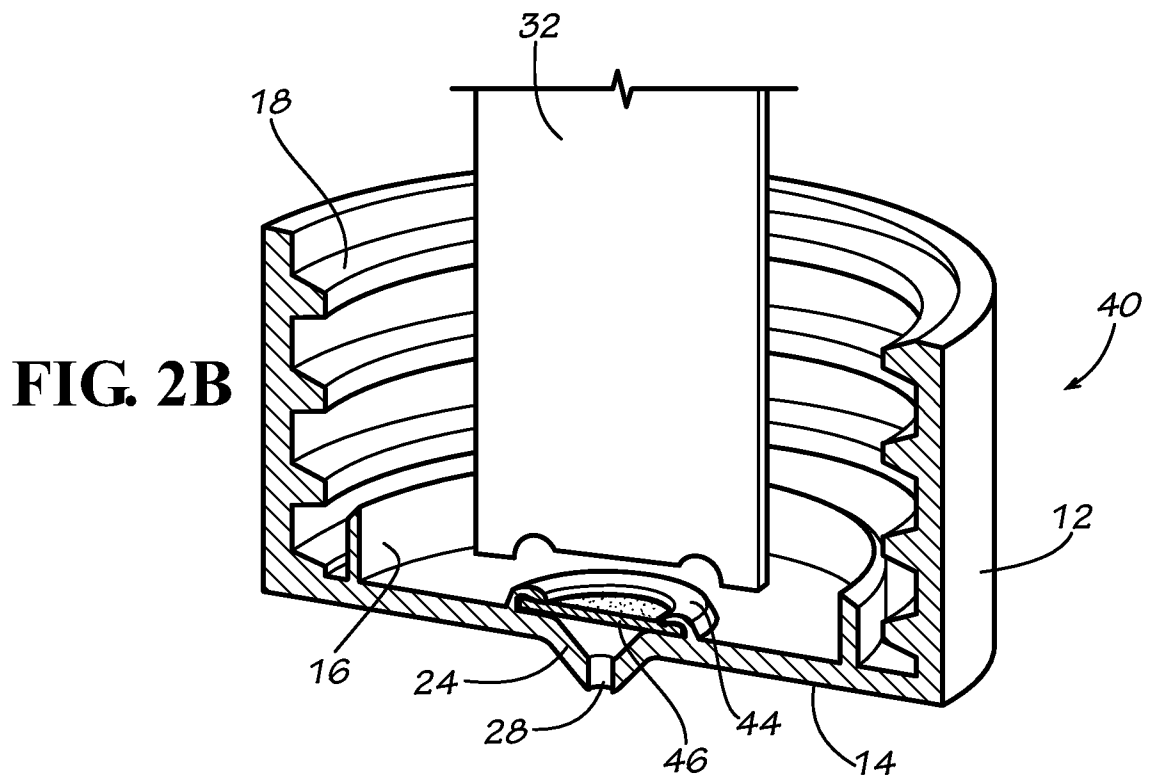
**FIG. 1B**



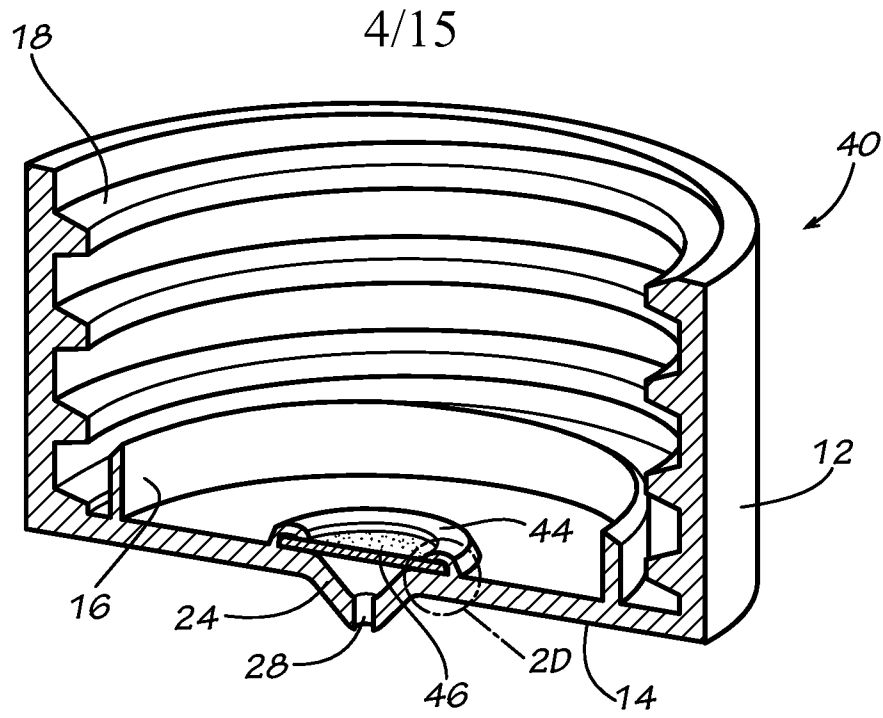
**FIG. 1C**



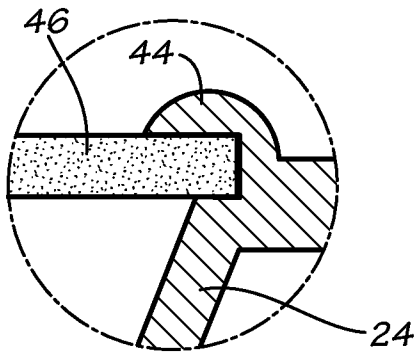
**FIG. 2A**



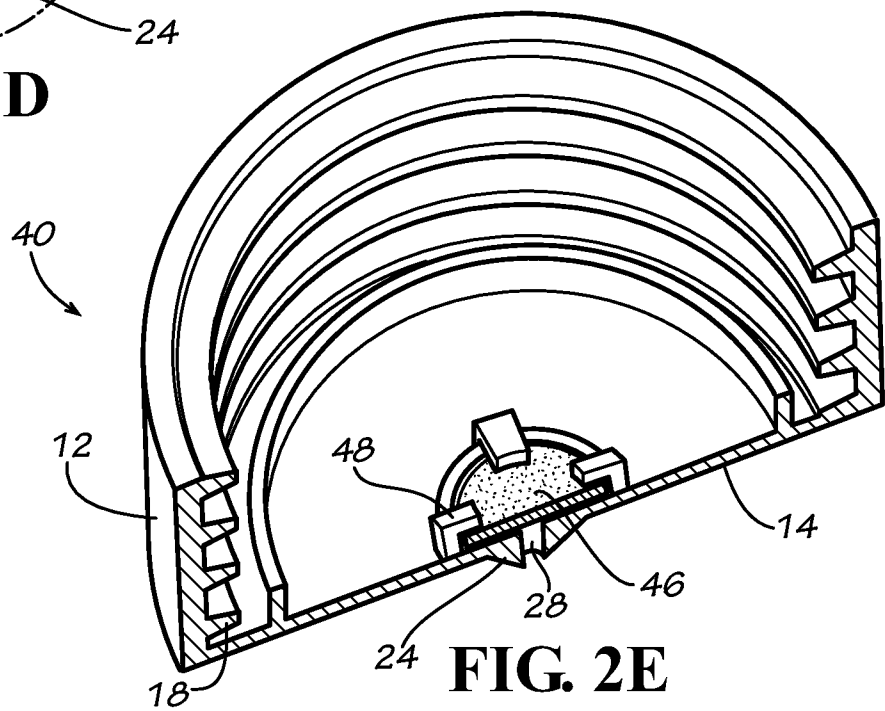
**FIG. 2B**



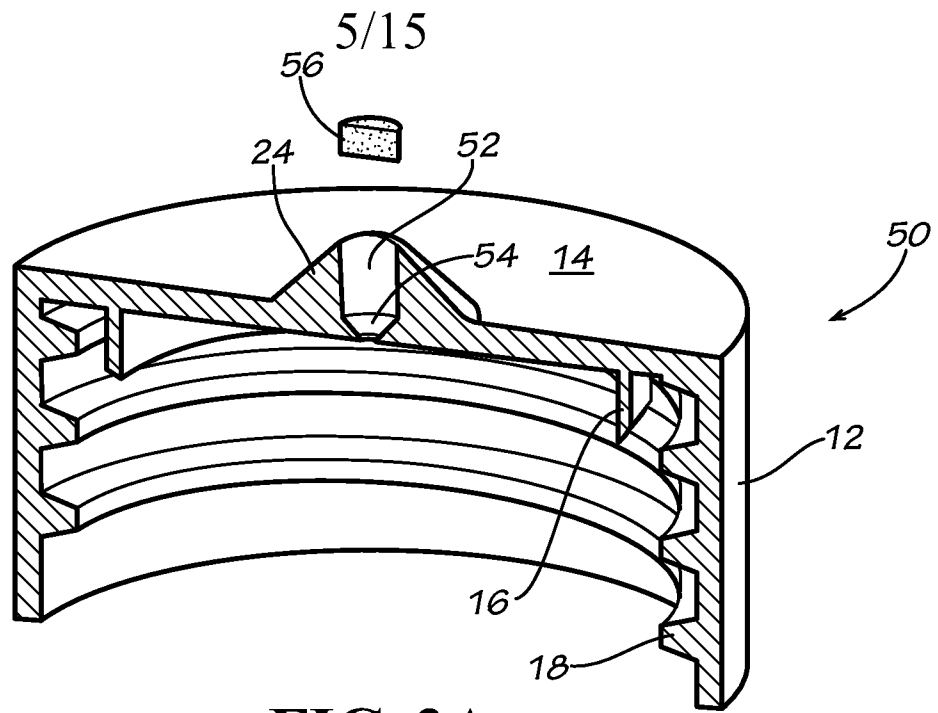
**FIG. 2C**



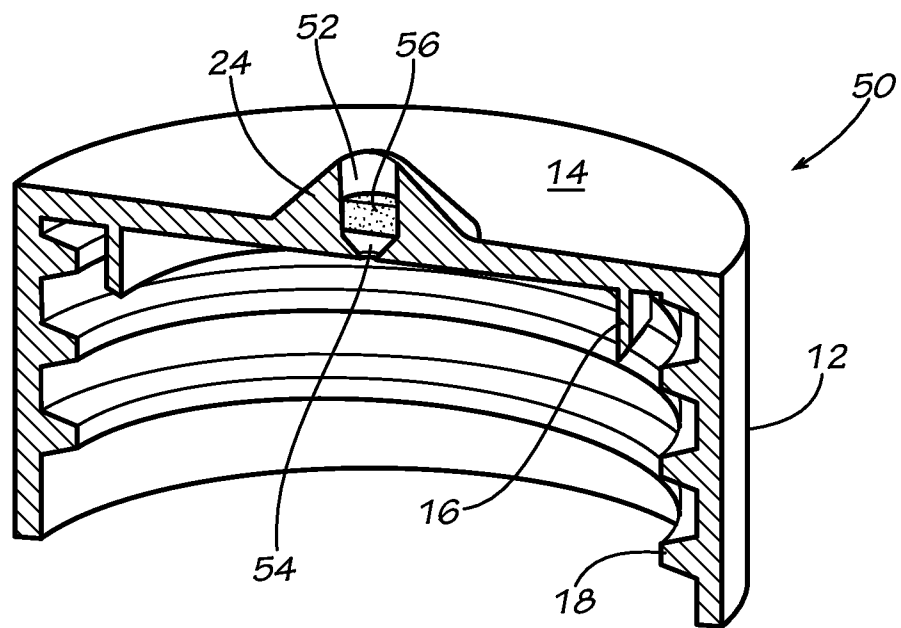
**FIG. 2D**



**FIG. 2E**

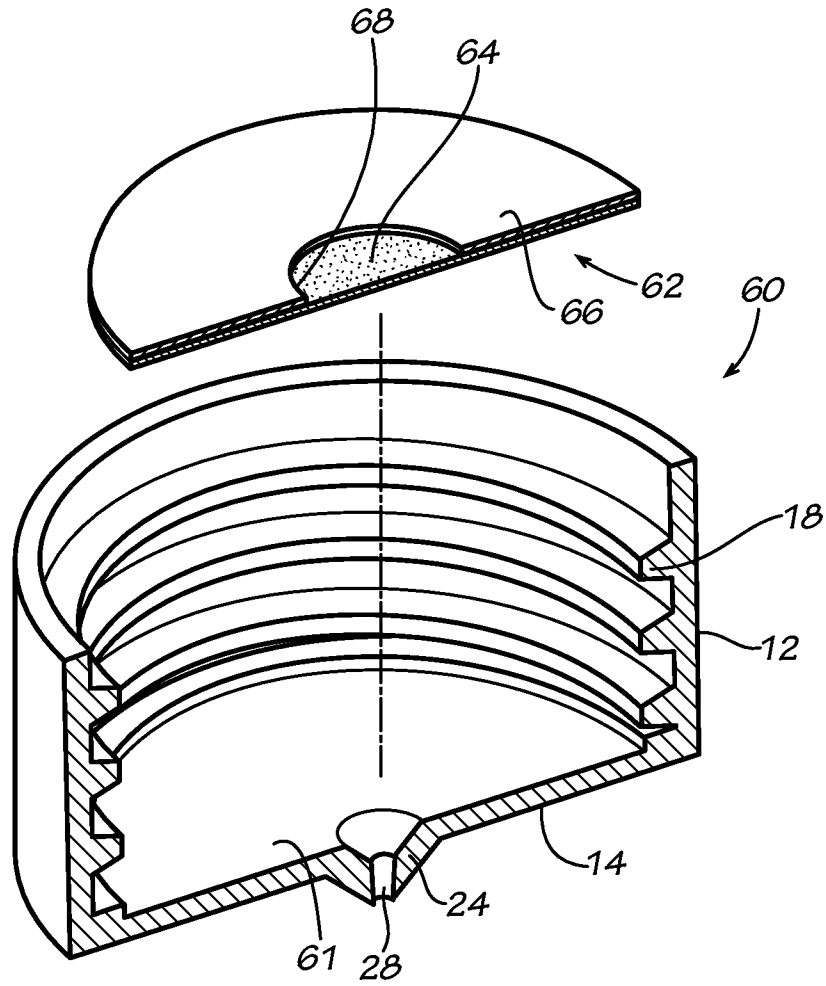


**FIG. 3A**



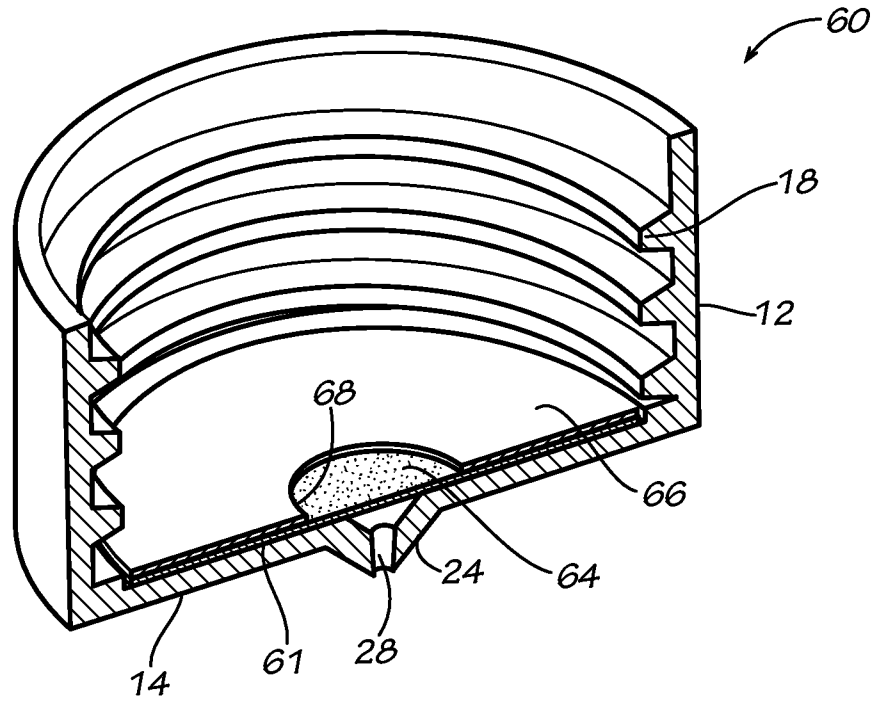
**FIG. 3B**

6/15

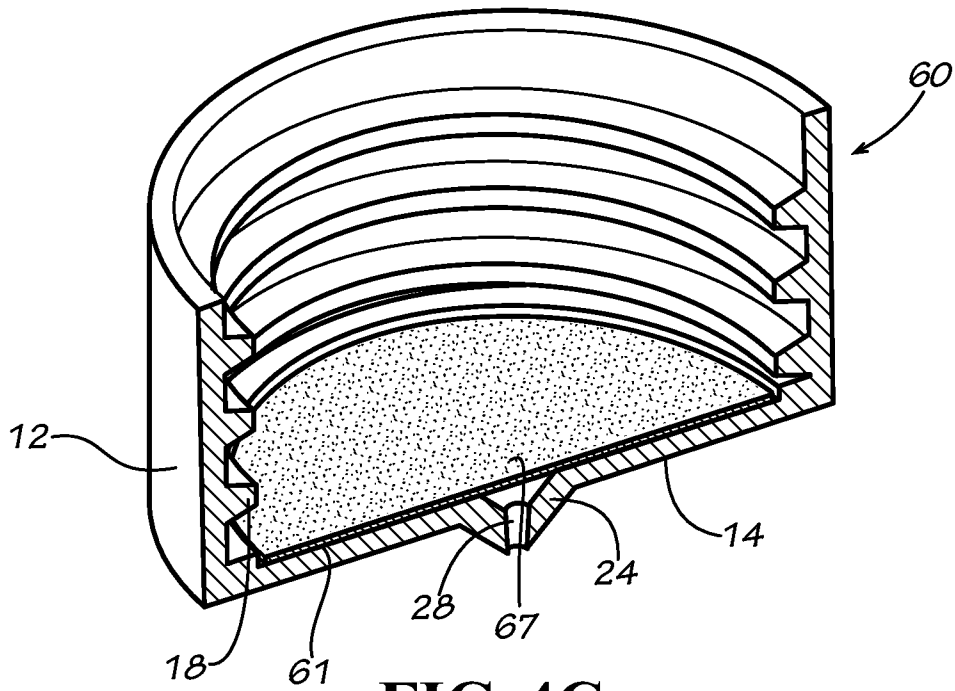


**FIG. 4A**

7/15

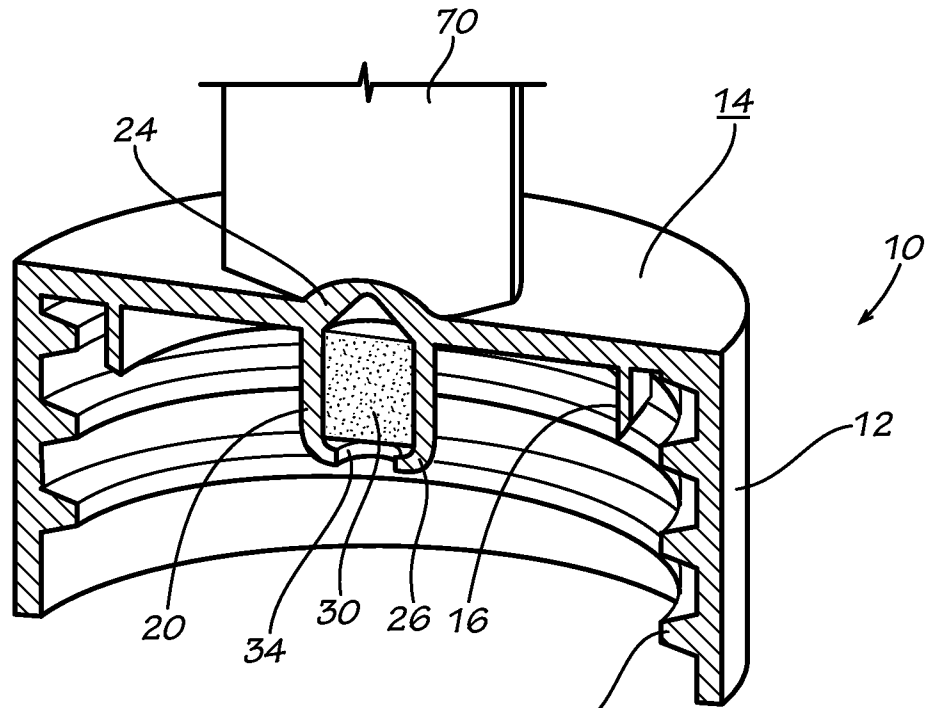


**FIG. 4B**

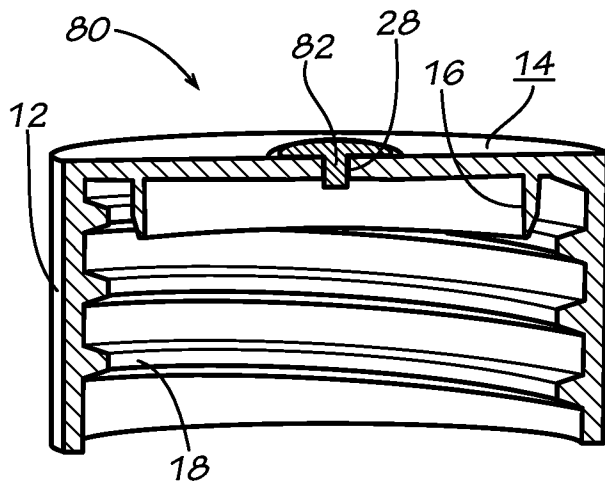


**FIG. 4C**

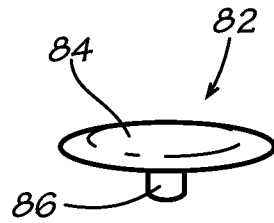
8/15



**FIG. 5**



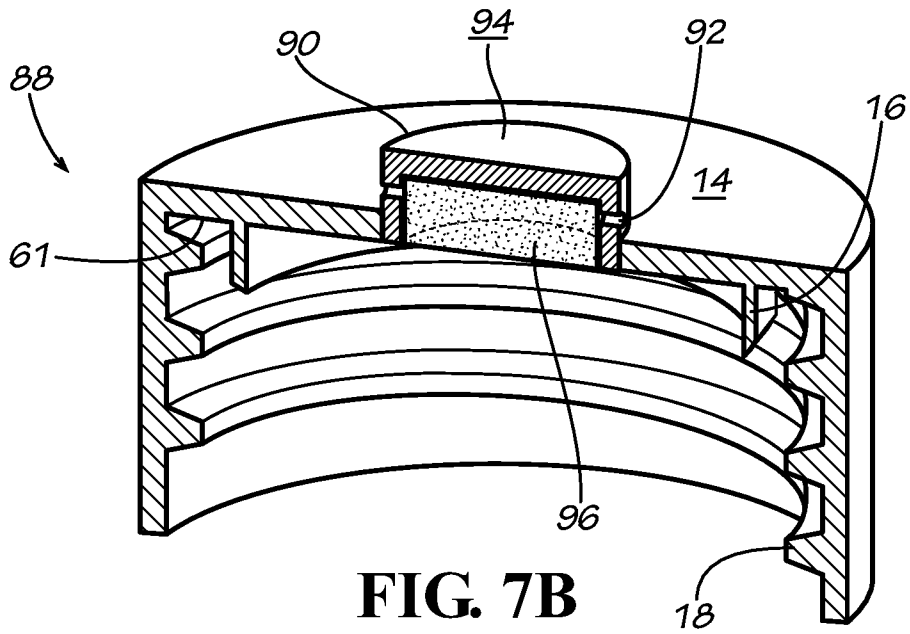
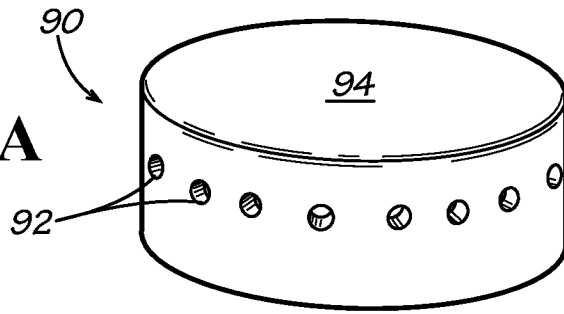
**FIG. 6A**



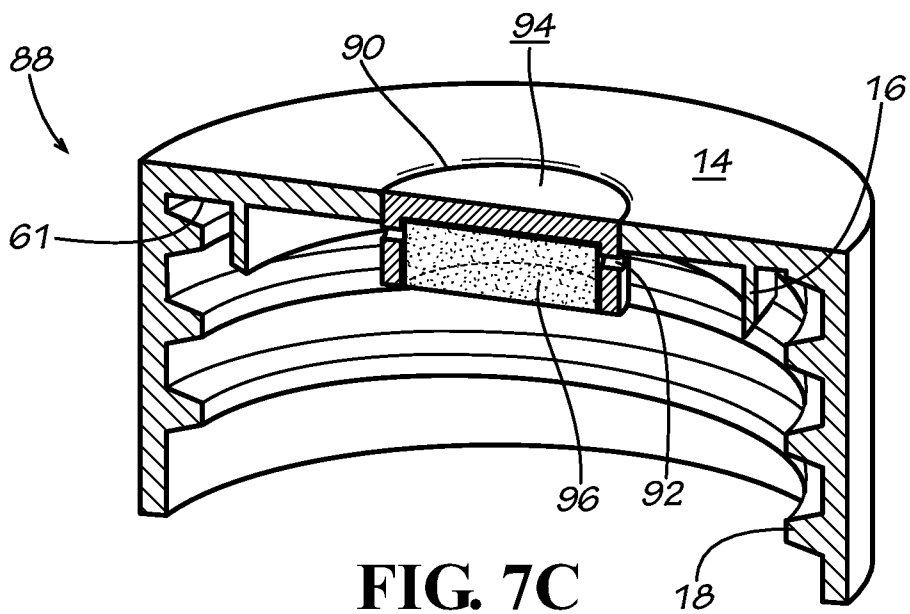
**FIG. 6B**

9/15

**FIG. 7A**

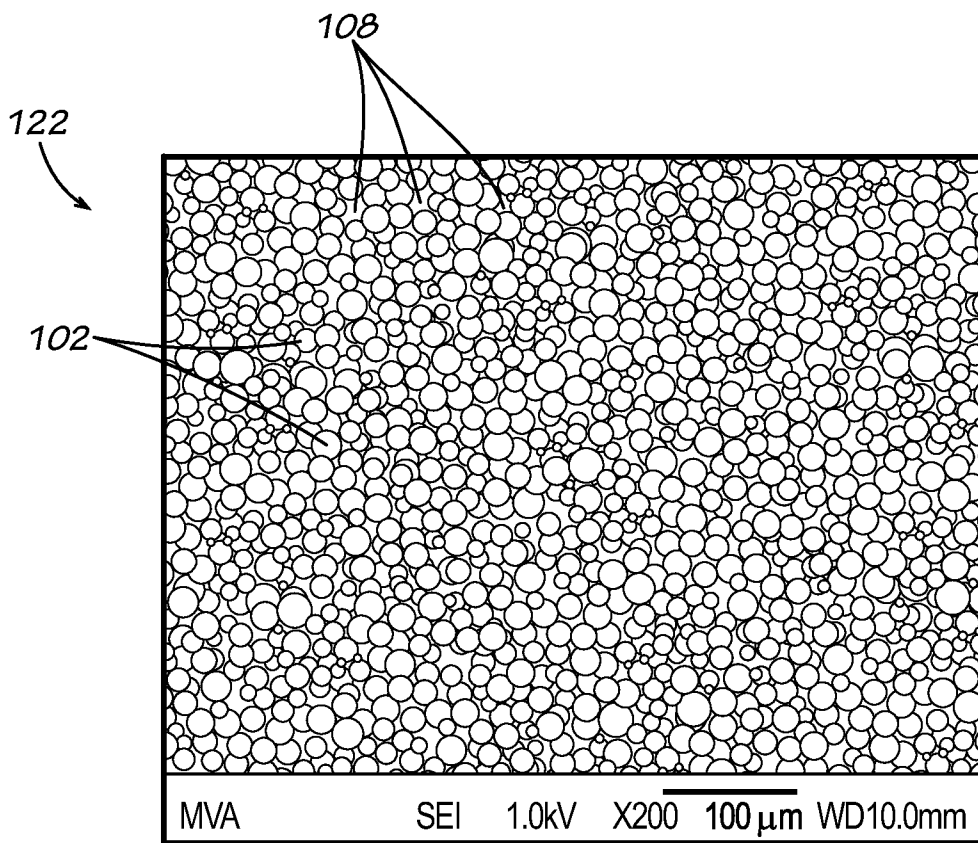


**FIG. 7B**



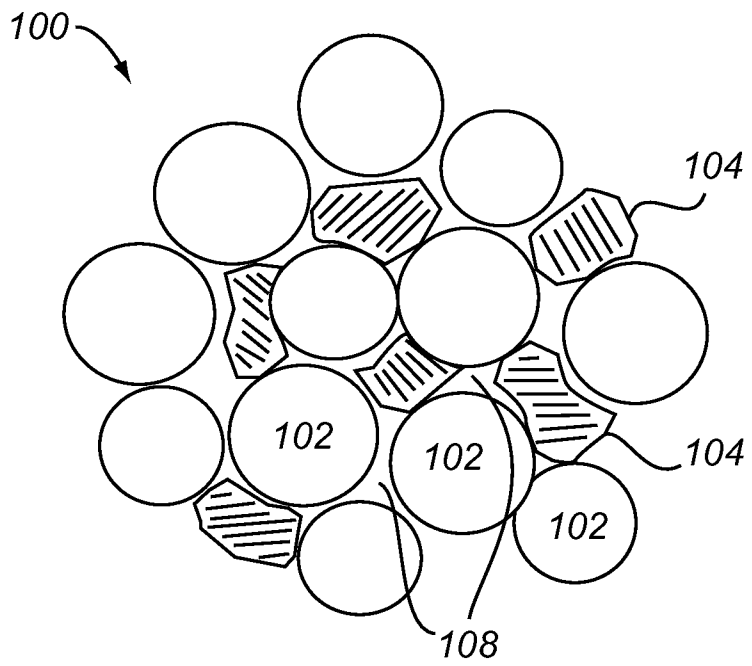
**FIG. 7C**

10/15

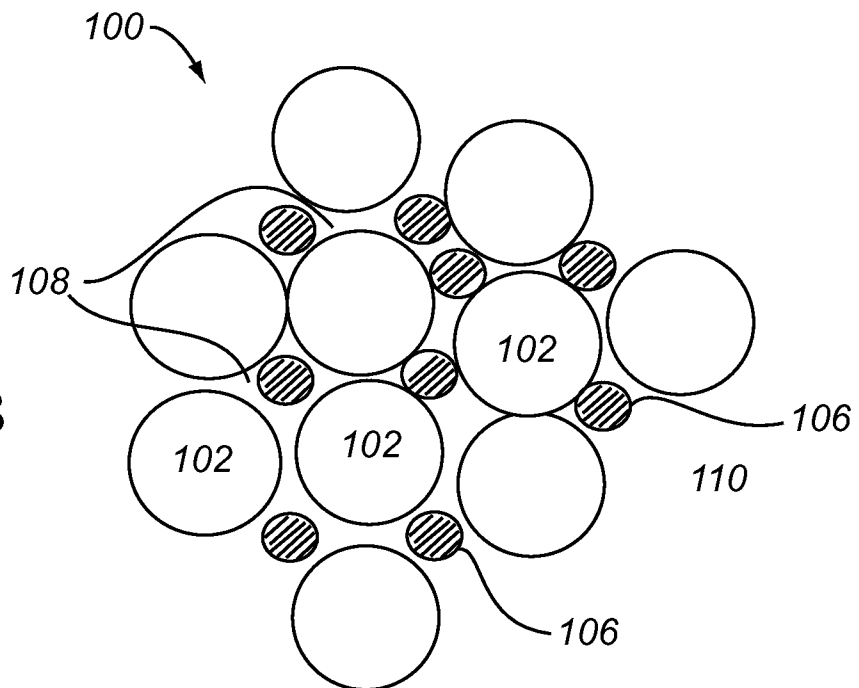


**FIG. 8**

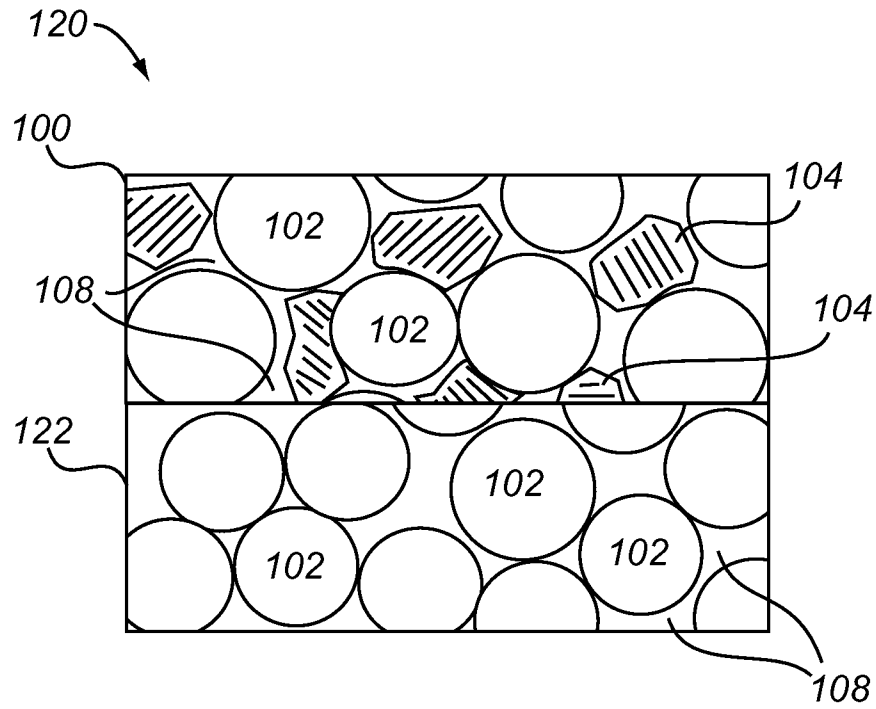
**FIG. 9A**



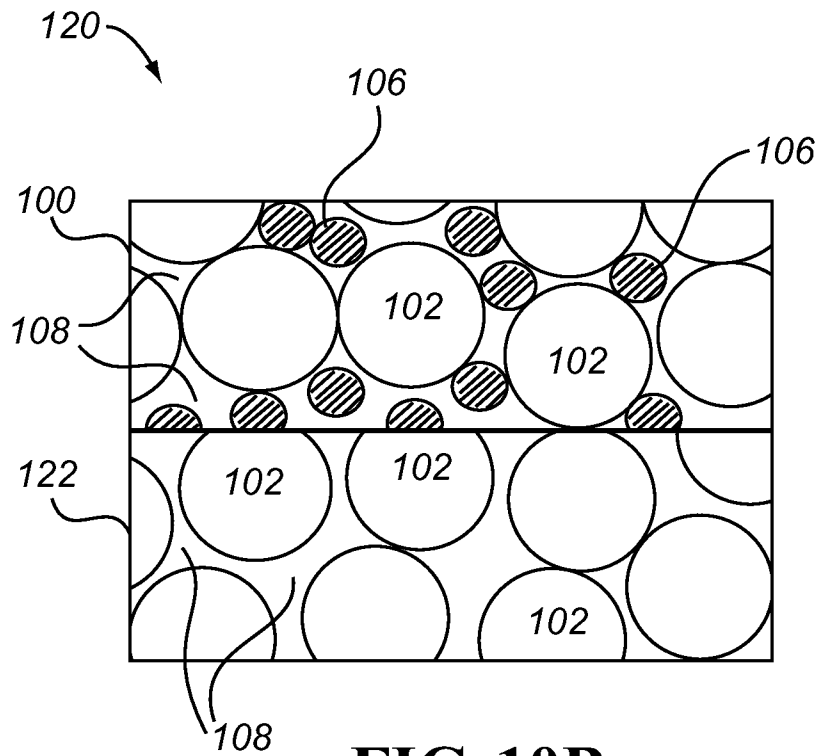
**FIG. 9B**



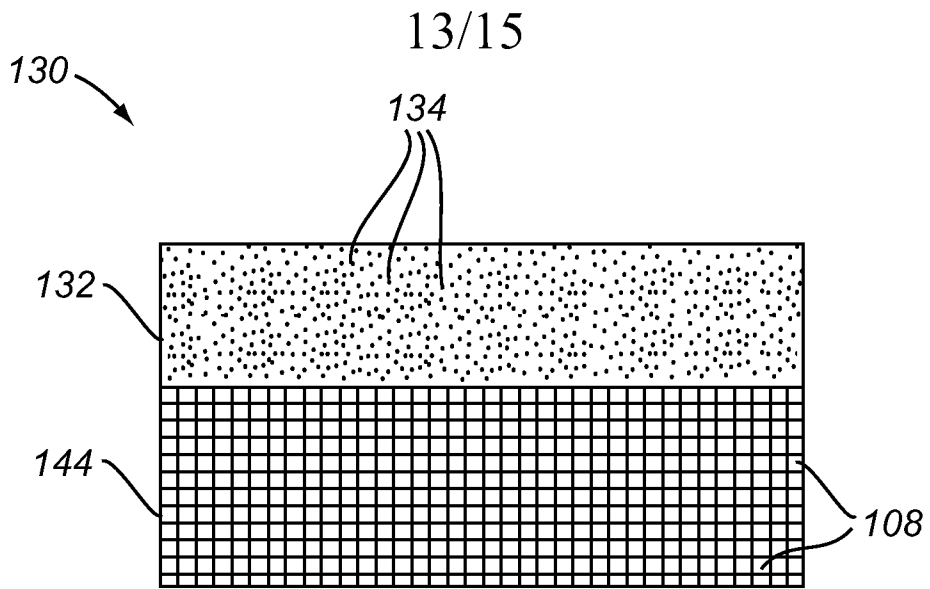
12/15



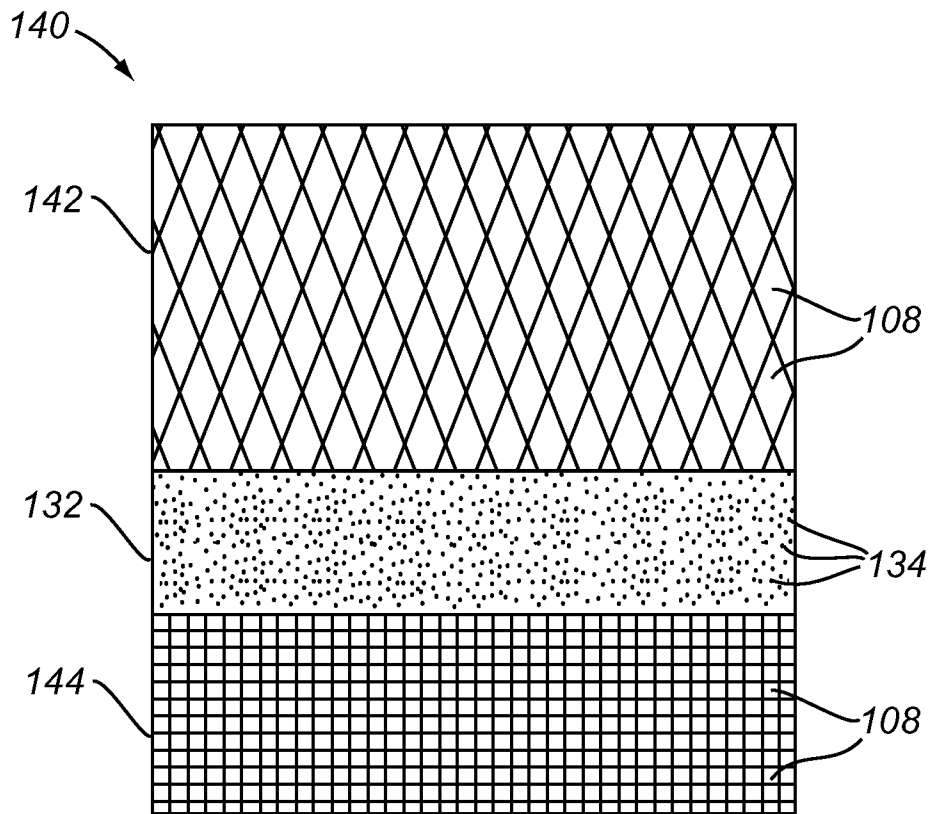
**FIG. 10A**



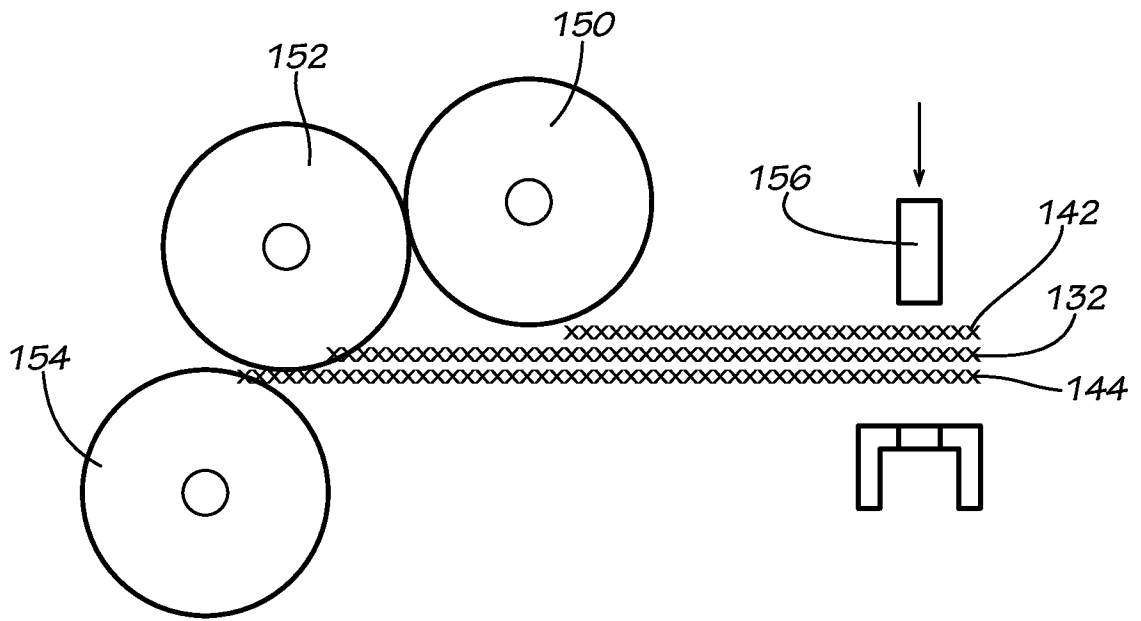
**FIG. 10B**



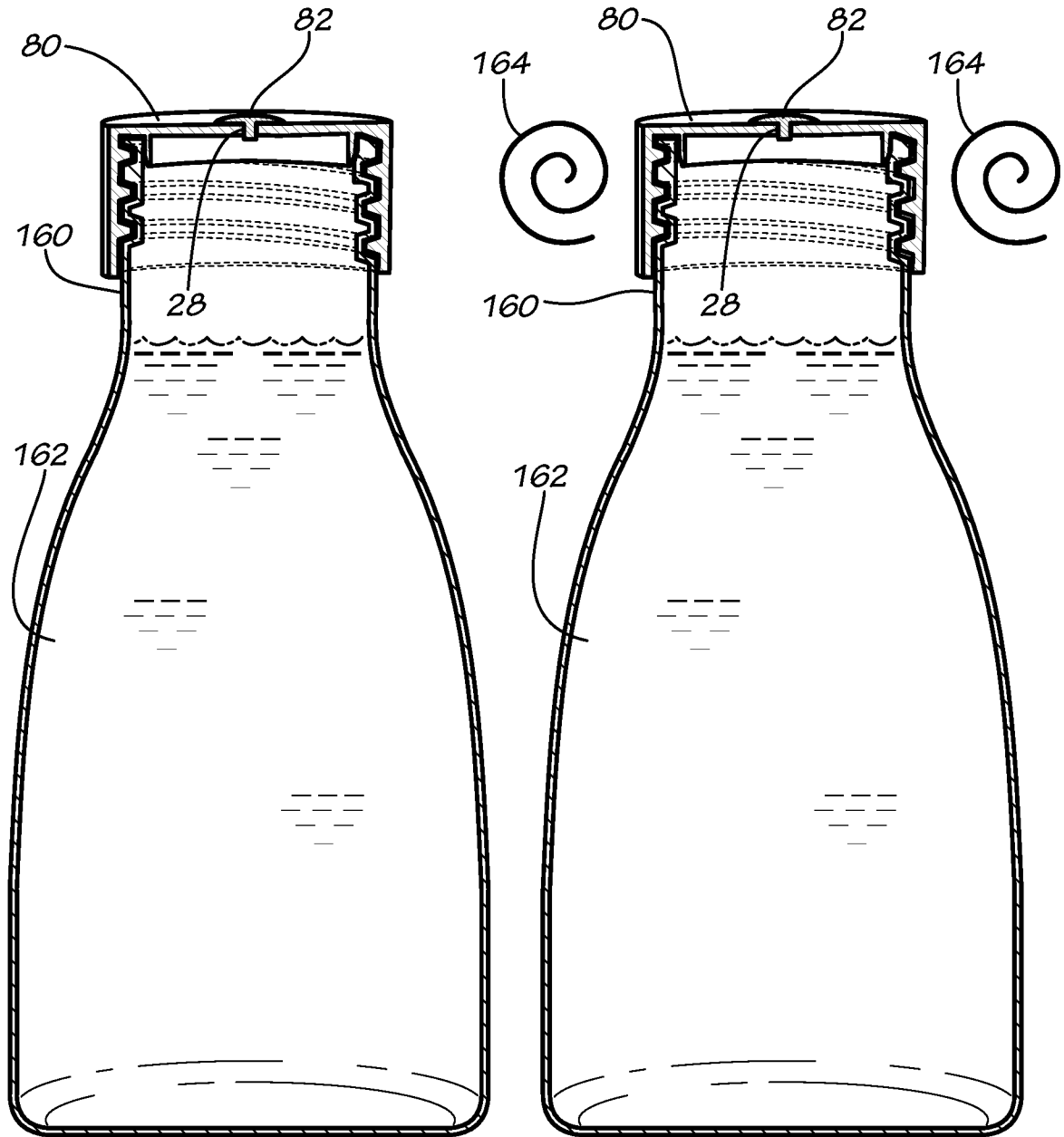
**FIG. 11**



**FIG. 12**



**FIG. 13**



**FIG. 14**

**FIG. 15**