



US00RE36525E

United States Patent [19] Pringle

[11] E

Patent Number: **Re. 36,525**

[45]

Reissued Date of Patent: **Jan. 25, 2000**

[54] **SPOOLABLE FLEXIBLE HYDRAULICALLY SET, STRAIGHT PULL RELEASE WELL PACKER**

[56]

References Cited

[75] Inventor: **Ronald E. Pringle**, Houston, Tex.

U.S. PATENT DOCUMENTS

4,441,561	4/1984	Garmong	166/387
4,844,166	7/1989	Going, III et al.	166/379
4,865,131	9/1989	Moore et al.	166/77
5,305,828	4/1994	White et al.	166/210

[73] Assignee: **Camco International Inc.**, Houston, Tex.

Primary Examiner—Hoang C. Dang
Attorney, Agent, or Firm—Tobor, Goldstein & Healey, LLP

[21] Appl. No.: **08/850,894**

[57]

ABSTRACT

[22] Filed: **May 2, 1997**

A coiled tubing completion system is provided with a plurality of completion apparatus, all of which is designed flush with the diameter of the coiled tubing outside diameter for avoiding upsets and are flexible, spoolable on a coiled tubing reel and having through bores large enough to pass wireline tools for performing other operations. The spoolable coiled tubing system may use standard coiled tubing well control equipment and can be used in live wells. The flush, flexible, spoolable and through bore completion equipment may include a tubing retrievable safety valve, an annular control valve, concentric gas lift valves, a zone packer, a landing nipple, a sliding sleeve, and may include at the end a non-flexible but flush and open bore production packer and pump out plug. The completion system may be retrieved through a retrieval system.

Related U.S. Patent Documents

Reissue of:

[64] Patent No.: **5,411,081**
Issued: **May 2, 1995**
Appl. No.: **08/278,213**
Filed: **Jul. 21, 1994**

U.S. Applications:

[62] Division of application No. 08/146,344, Nov. 1, 1993, Pat. No. 5,411,085.

[51] **Int. Cl.⁷** **E21B 33/12**

[52] **U.S. Cl.** **166/120**

[58] **Field of Search** **166/120, 77.1, 166/77.2**

5 Claims, 24 Drawing Sheets

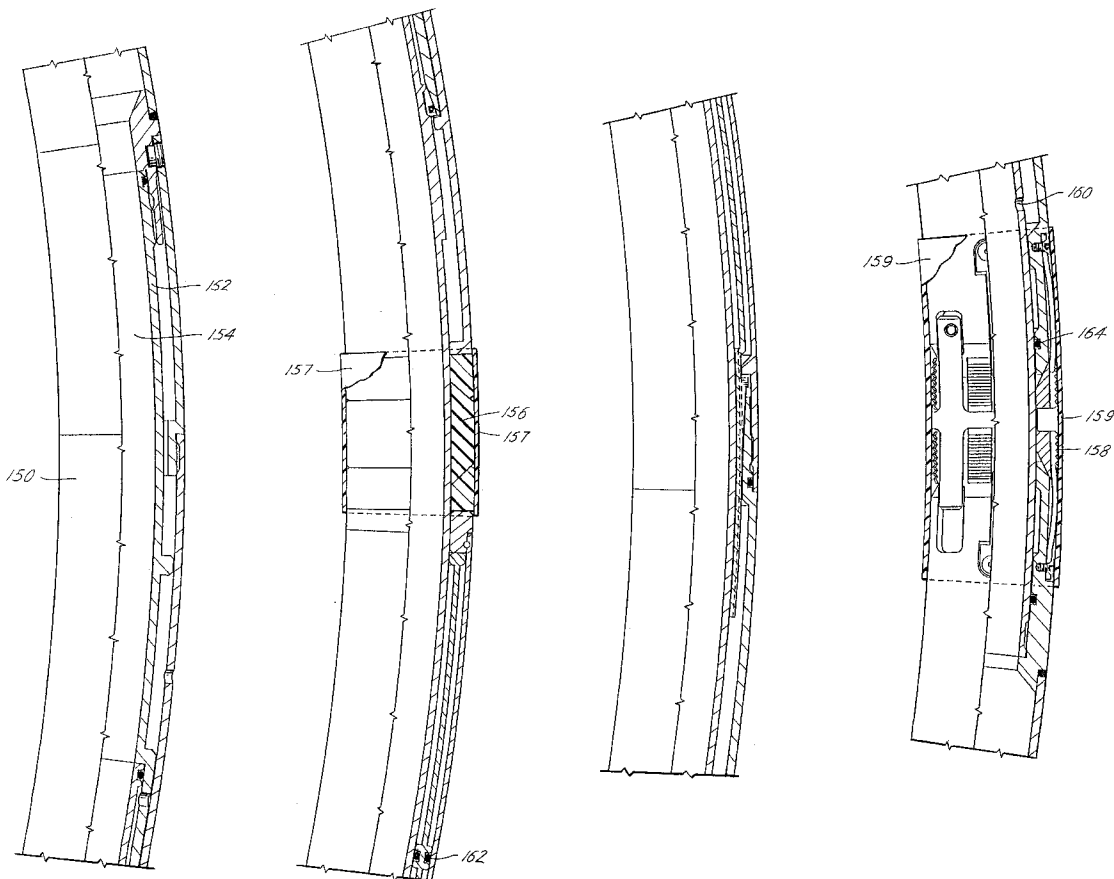

Fig. 1A

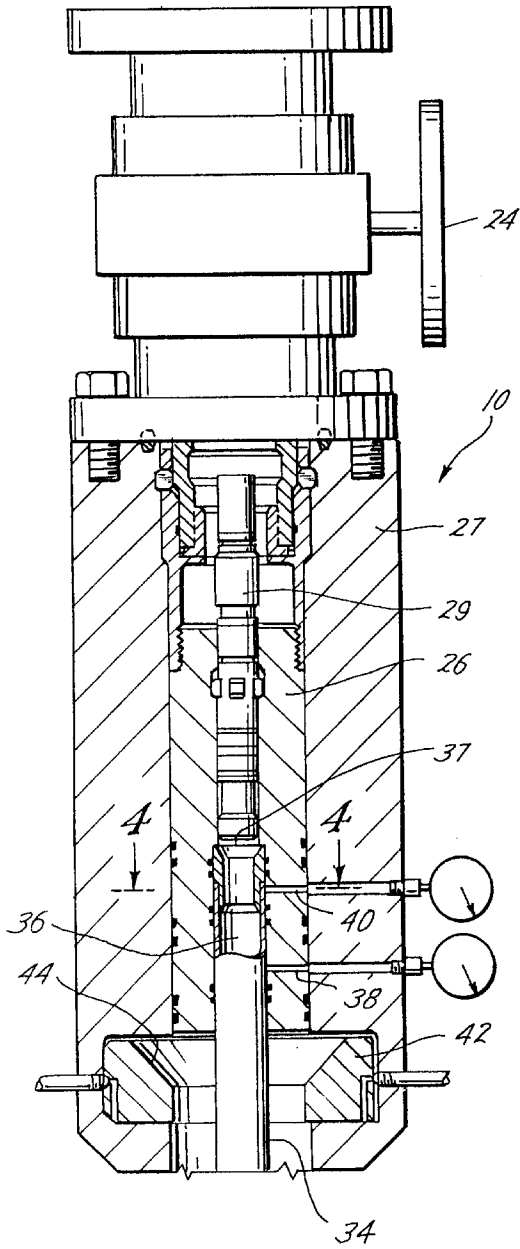

Fig. 1B

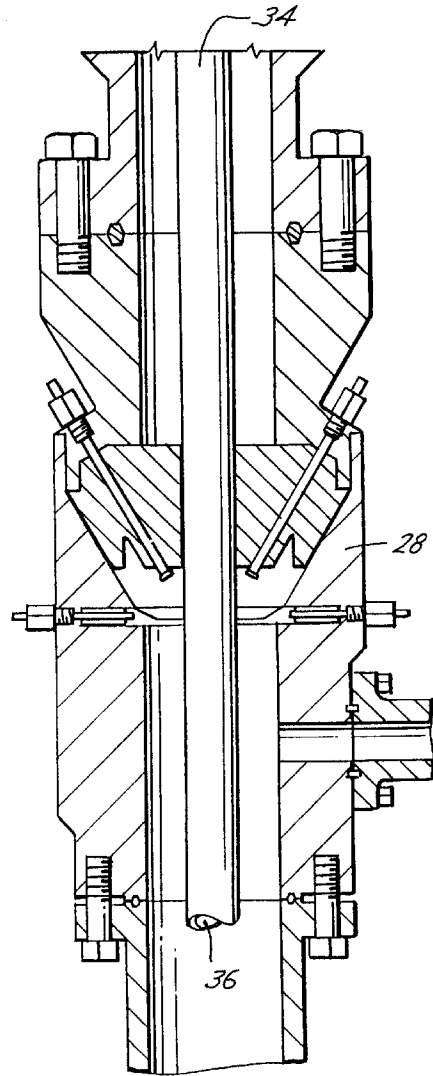

Fig. 1C

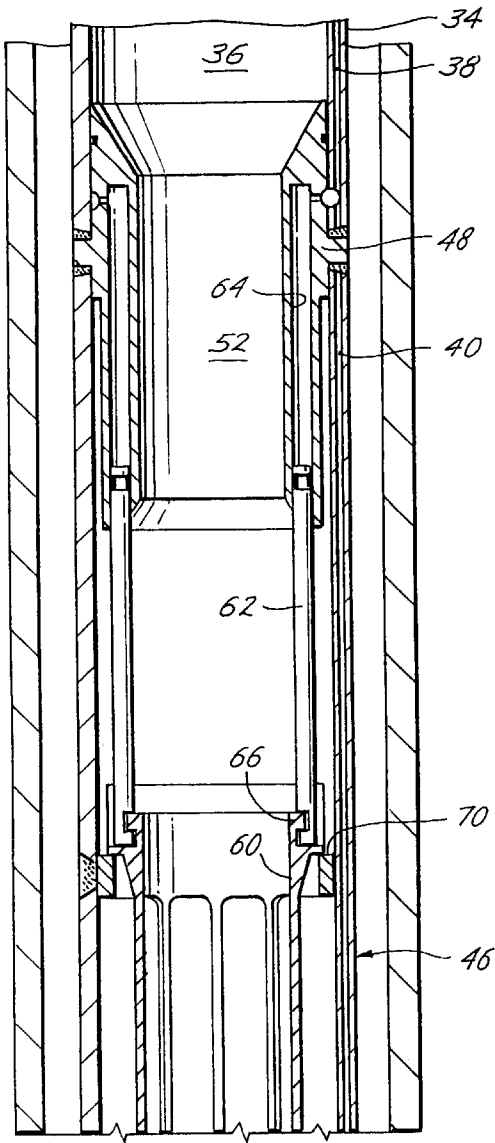

Fig. 1D

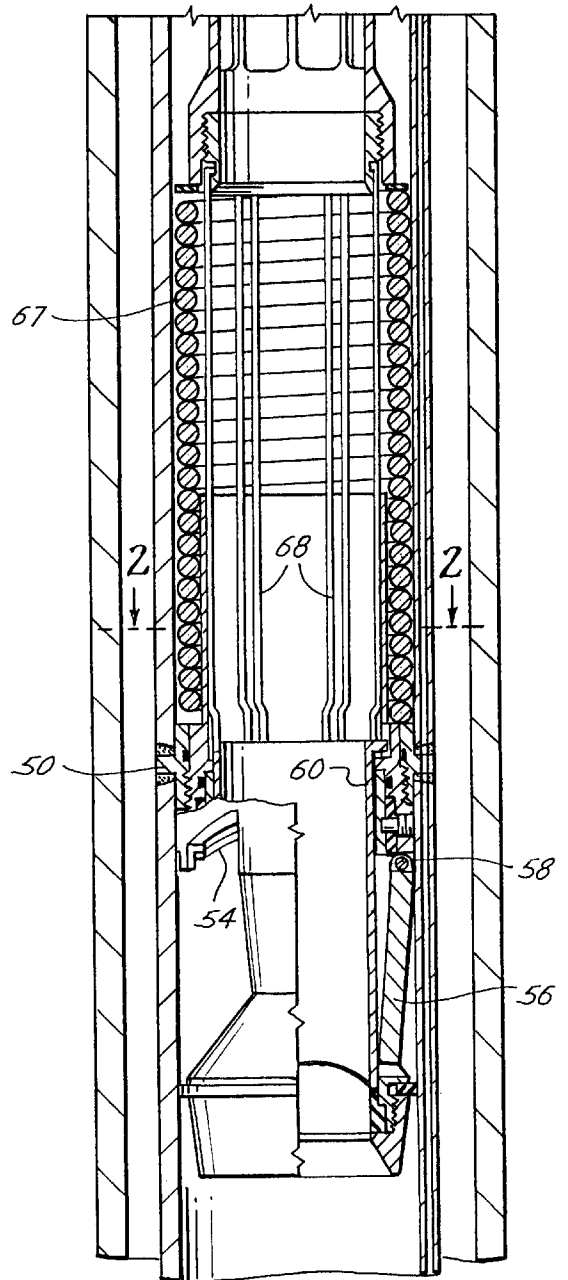

Fig. 1E

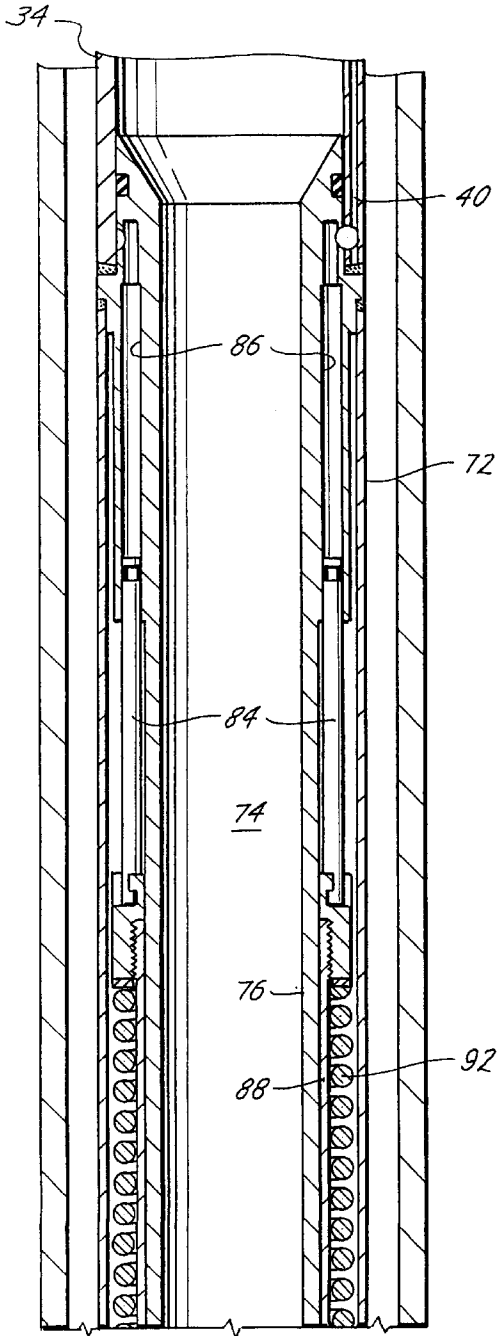

Fig. 1F

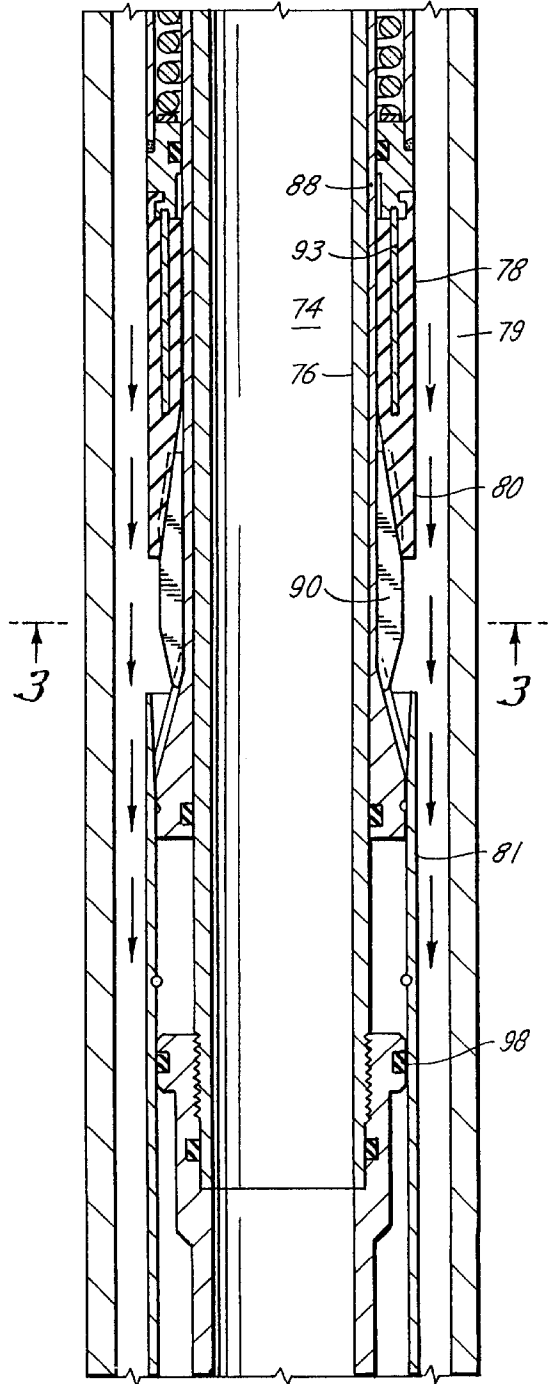

Fig. 1G

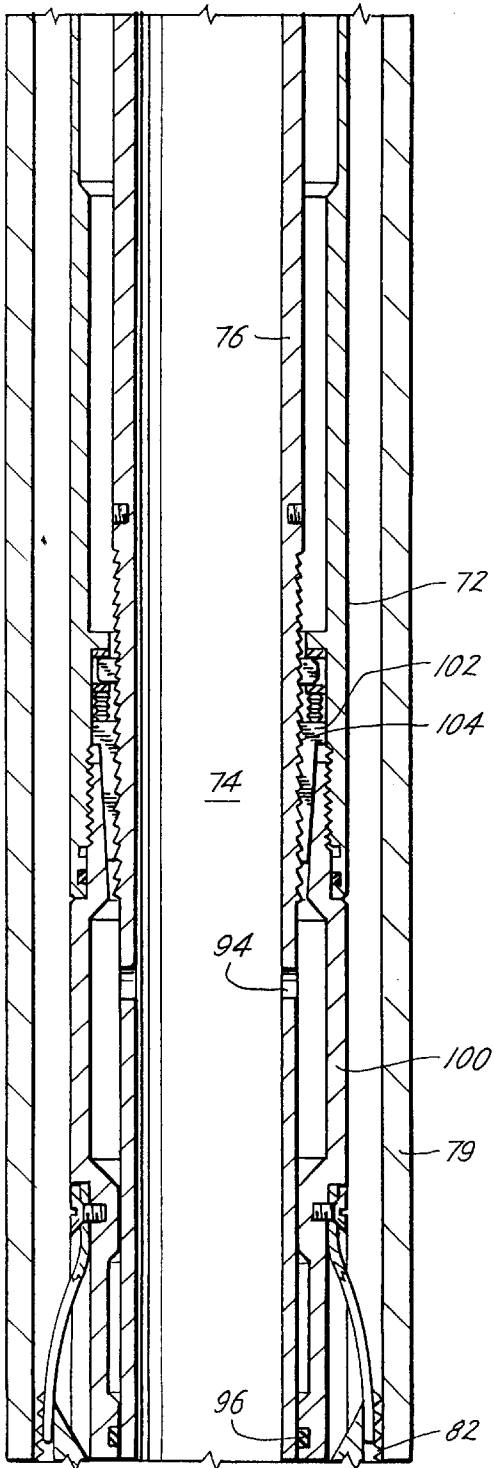

Fig. 1H

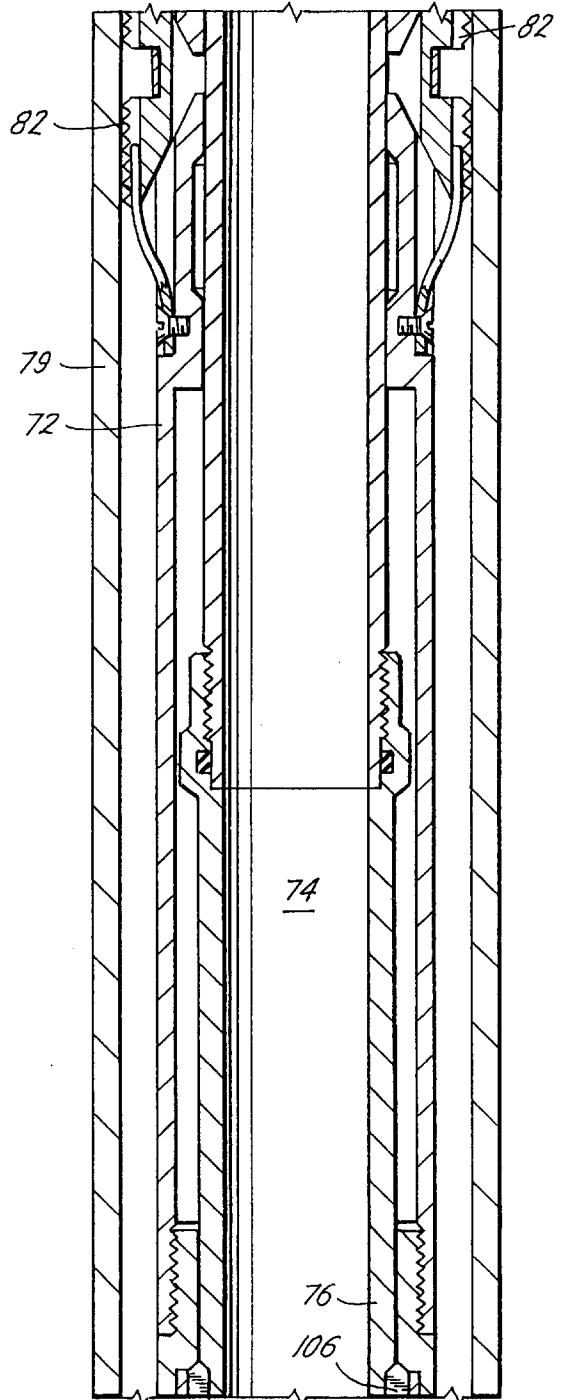

Fig. 1I

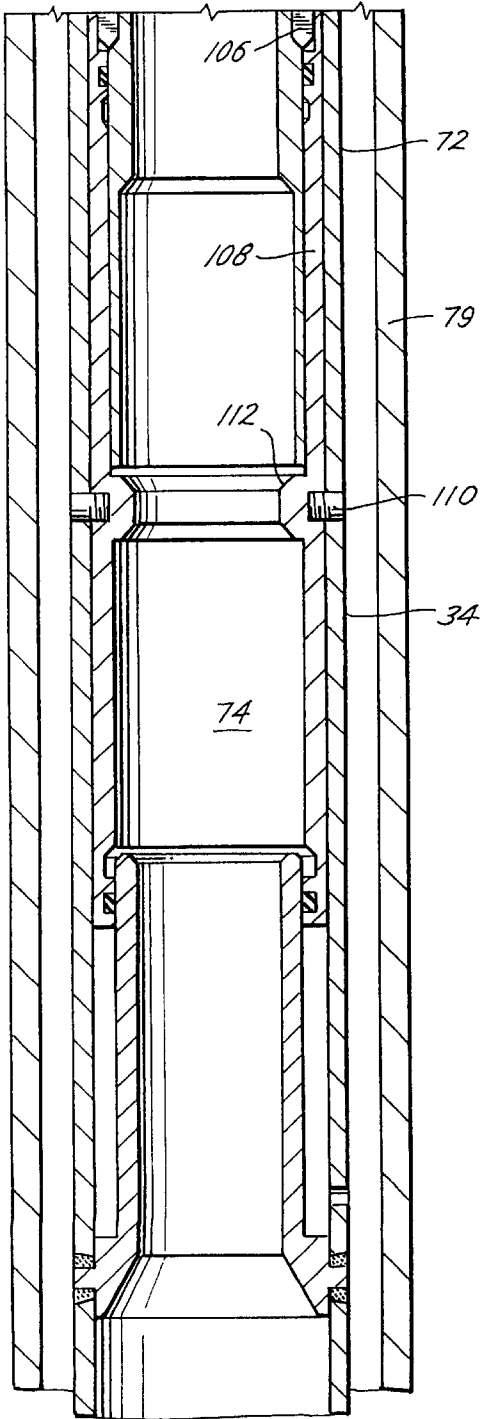

Fig. 1J

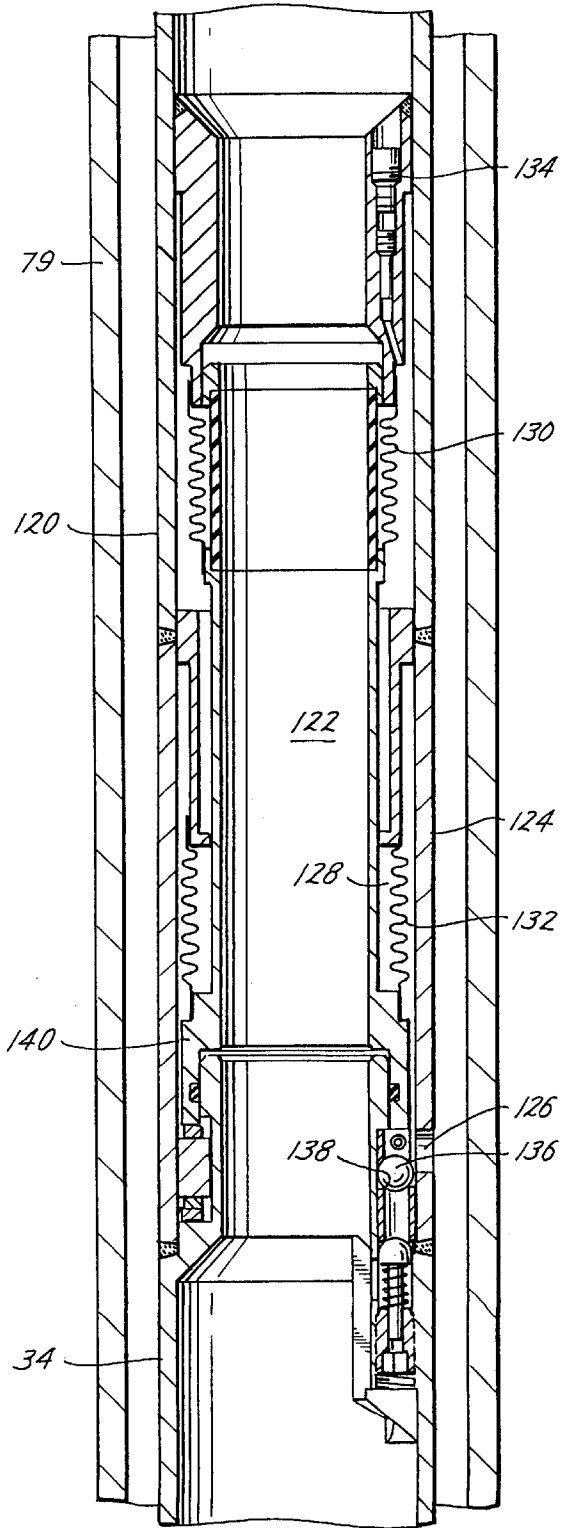

Fig. 1K

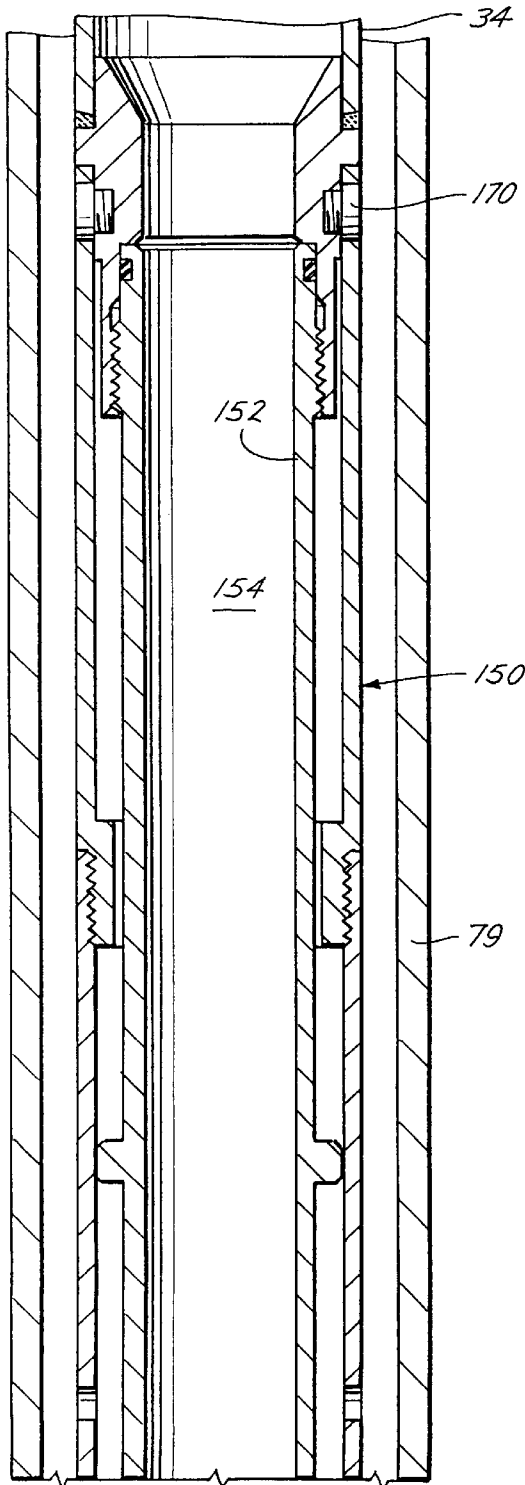

Fig. 1L

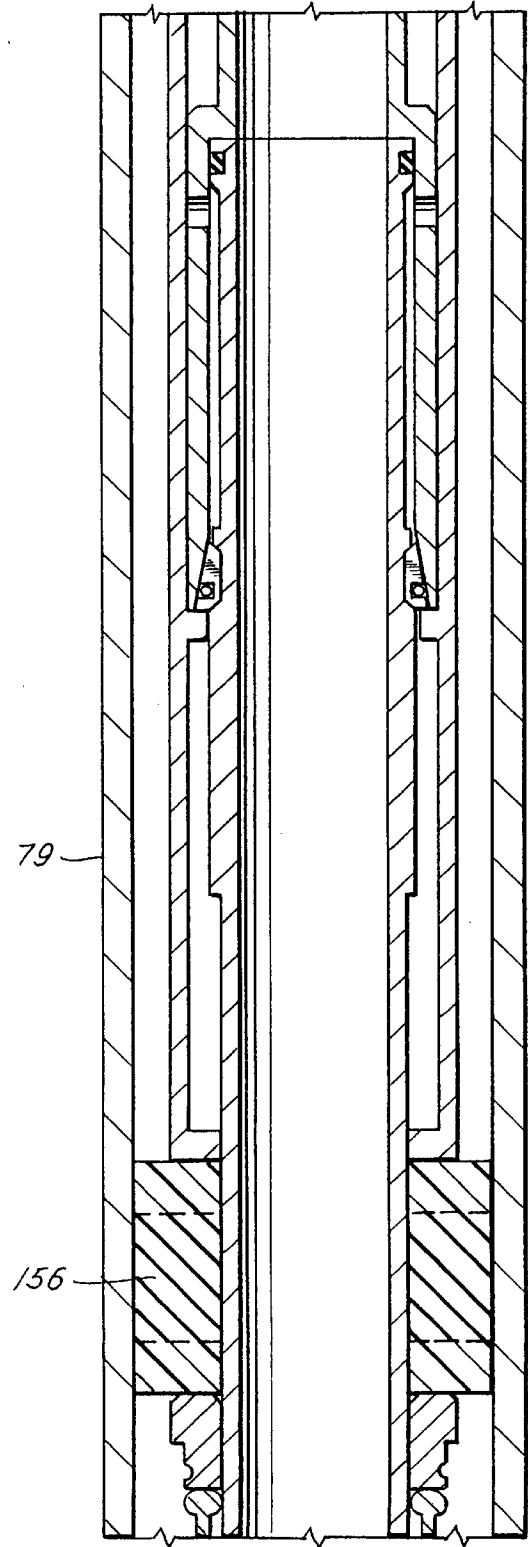

Fig. 1M

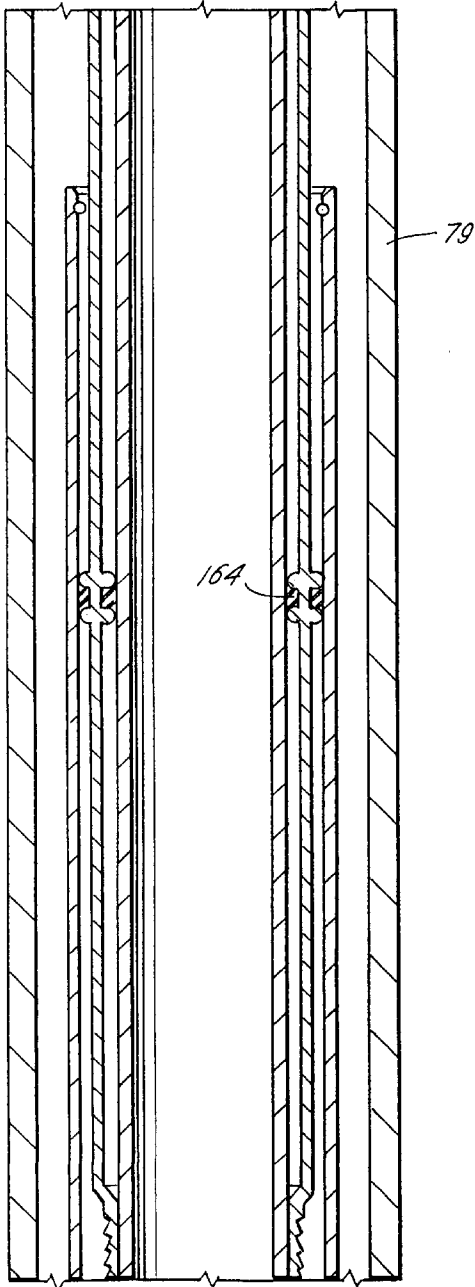

Fig. 1N

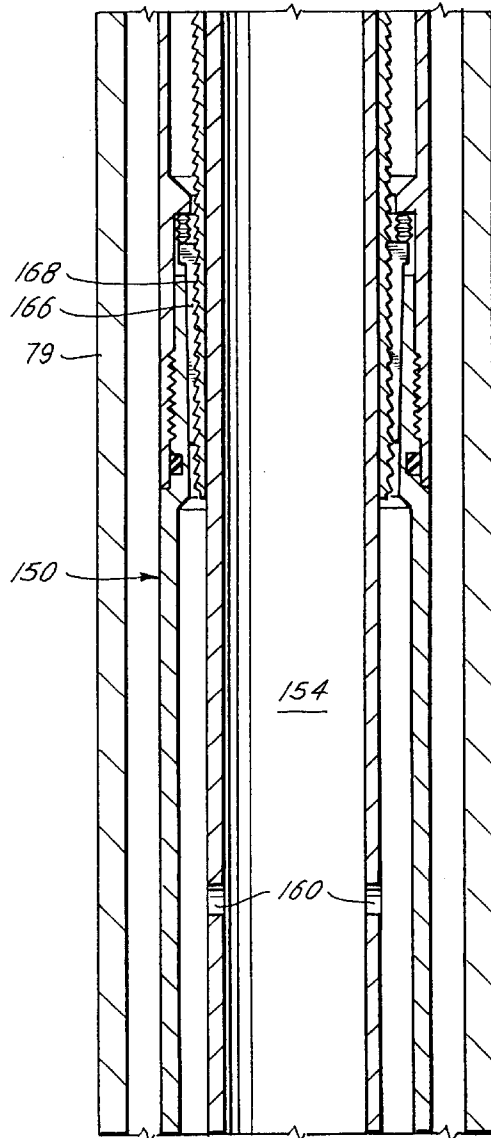

Fig. 10

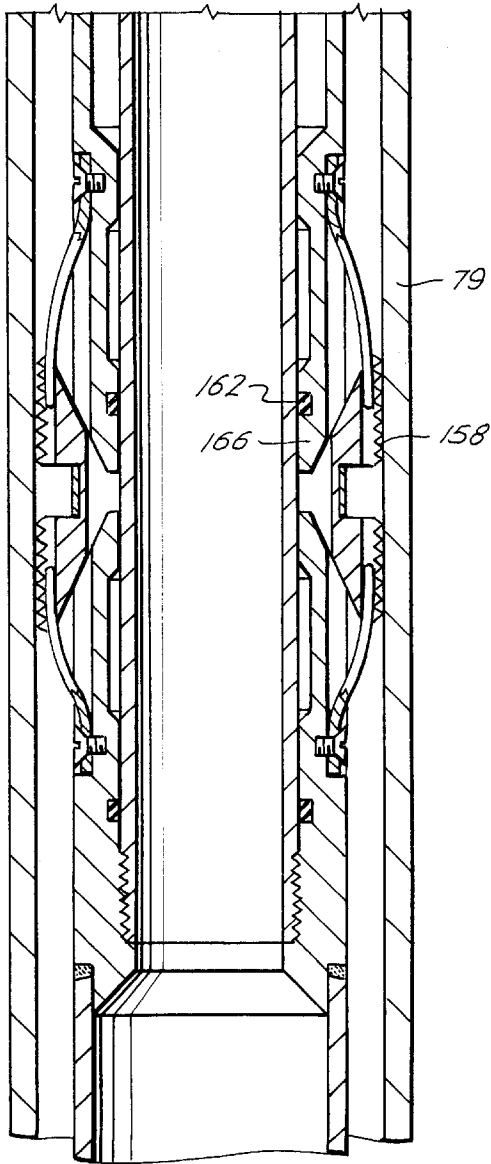

Fig. 1P

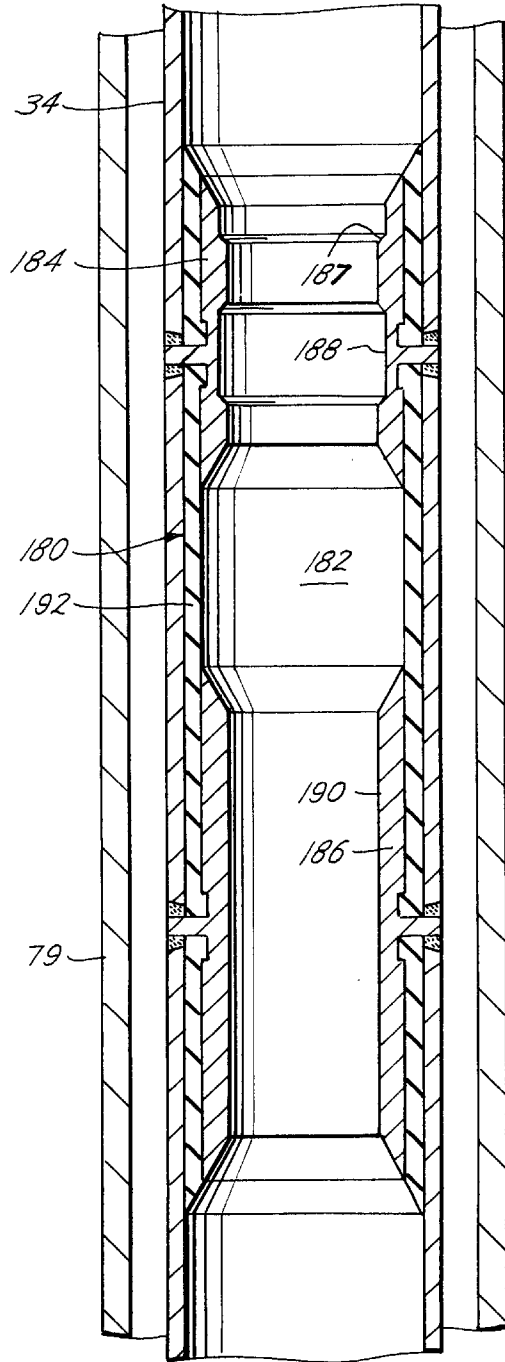

Fig. 1Q

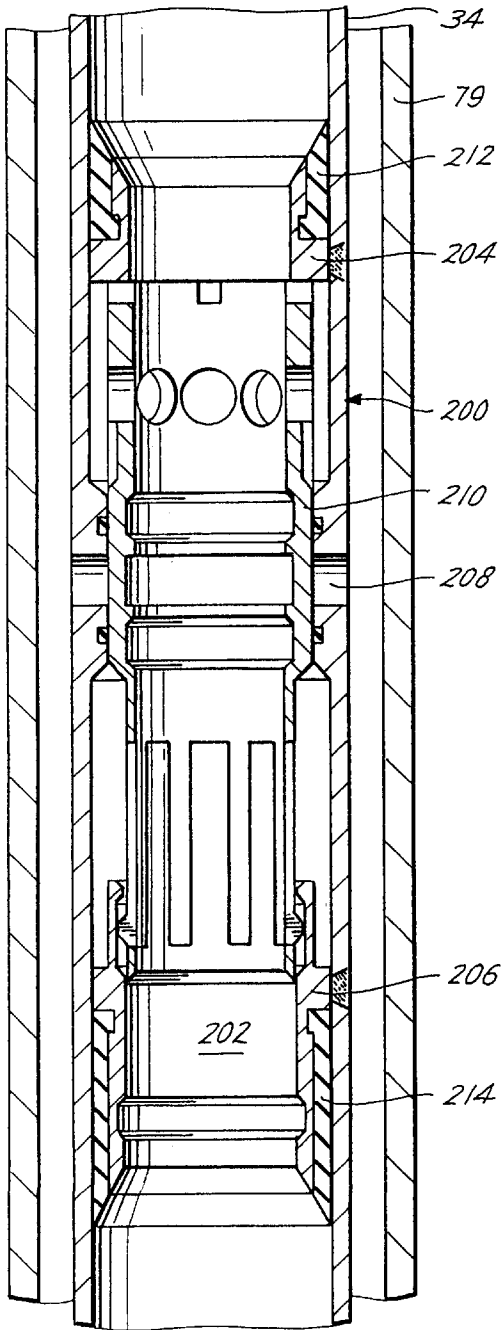

Fig. 1R

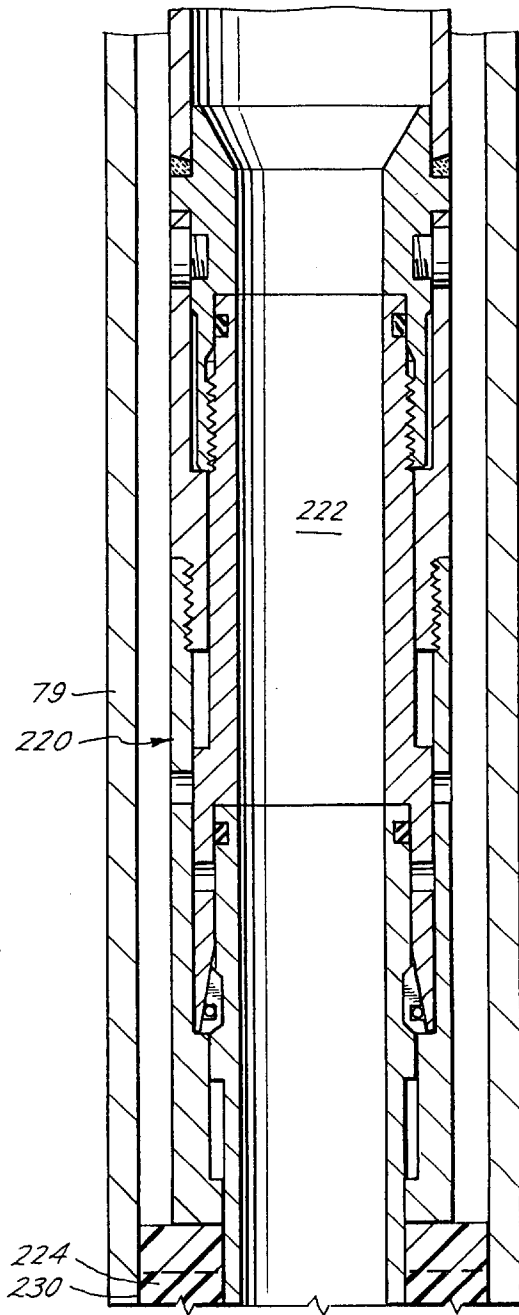

Fig. 1S

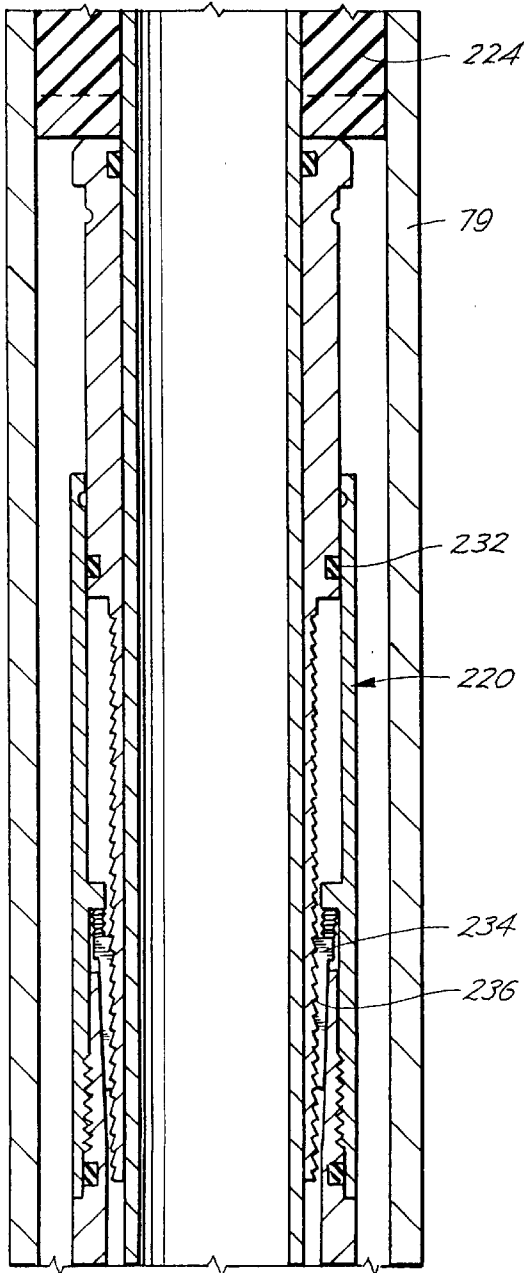
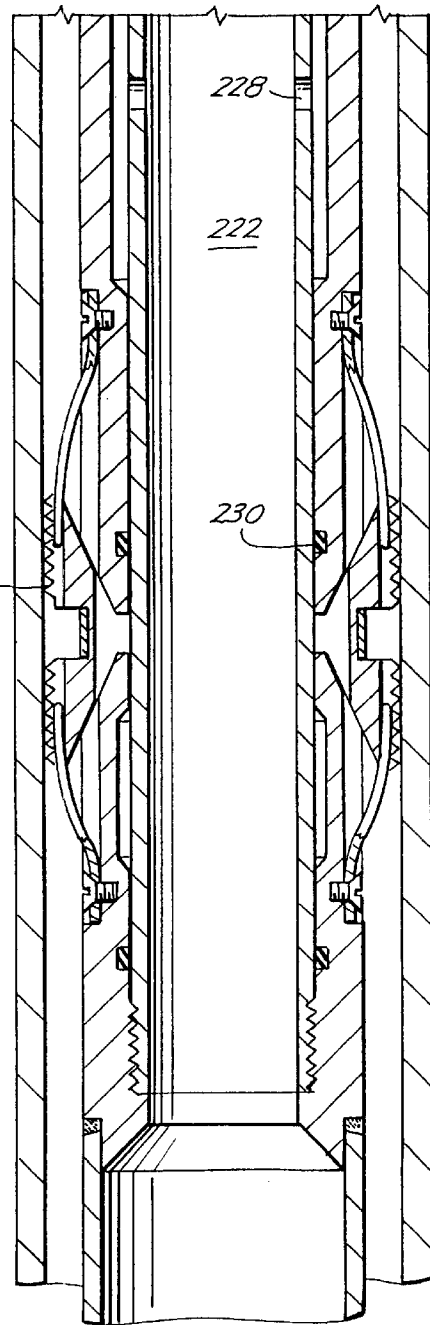

Fig. 1T



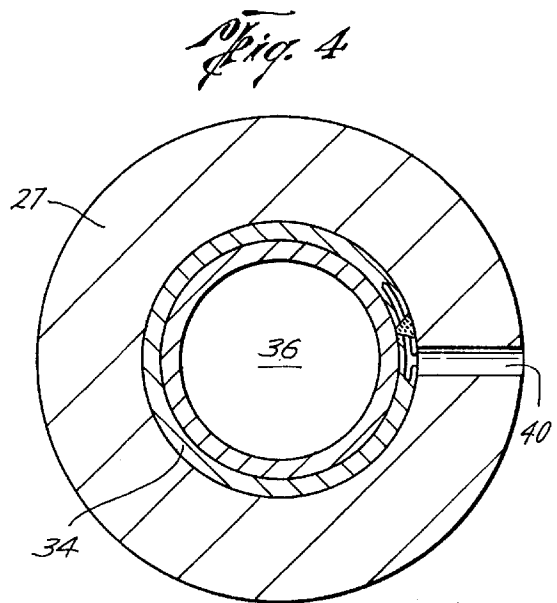
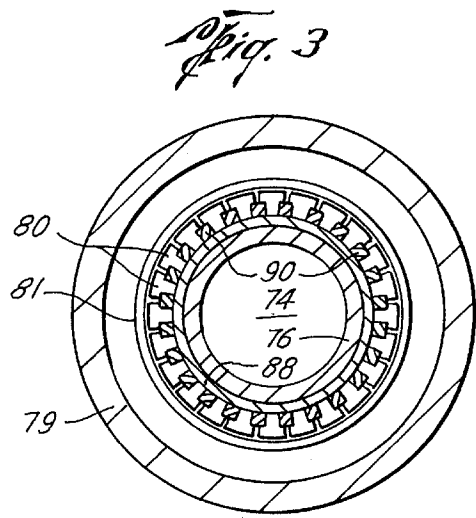
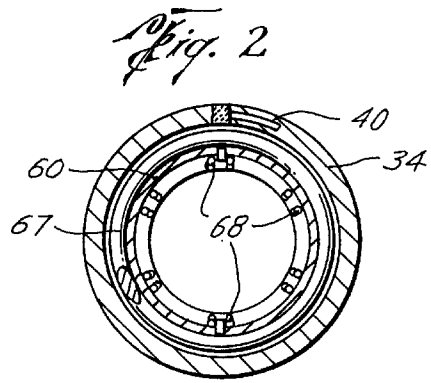
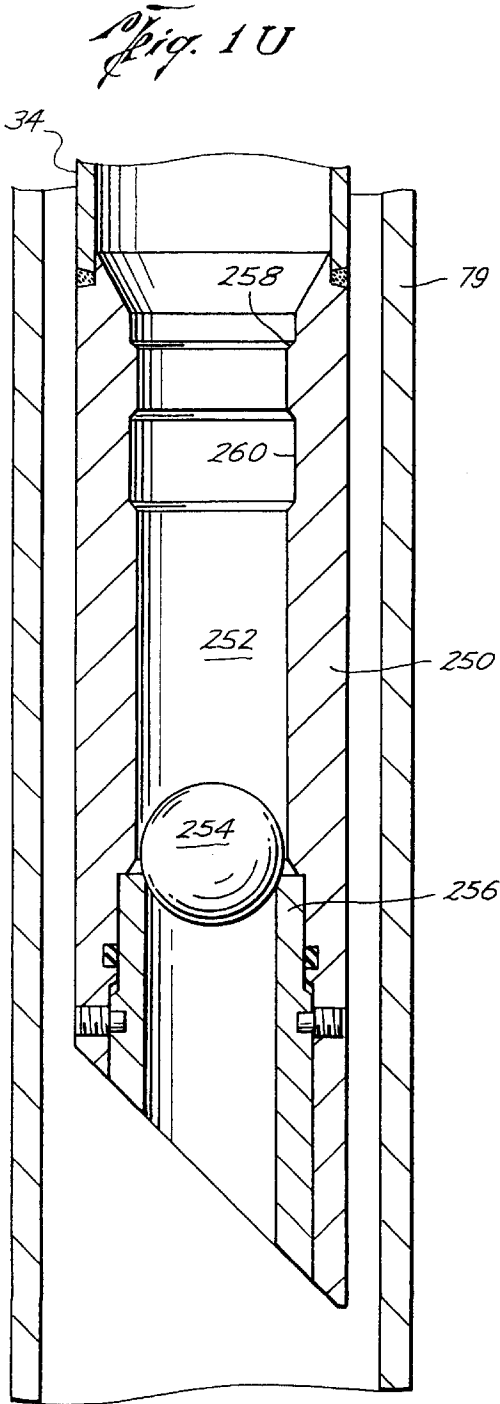

Fig. 5

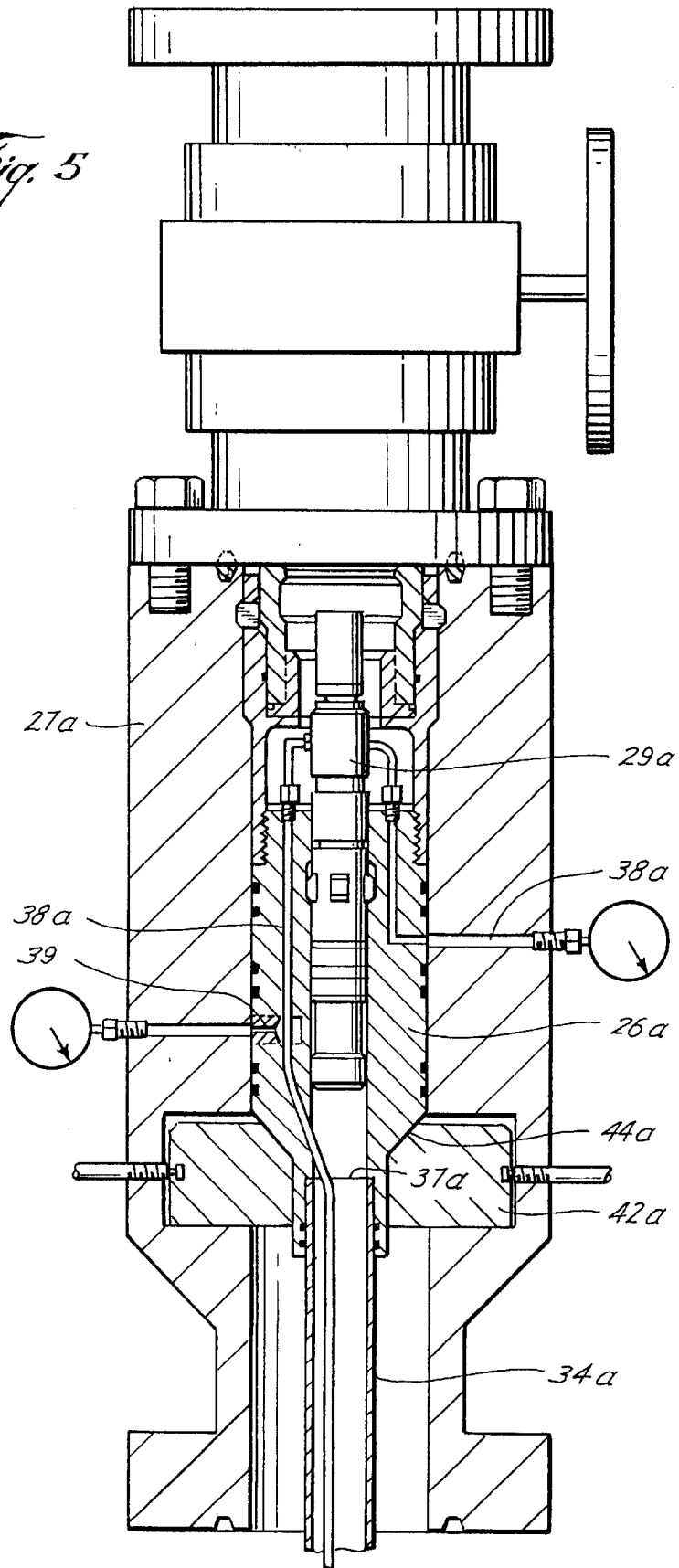

Fig. 6A

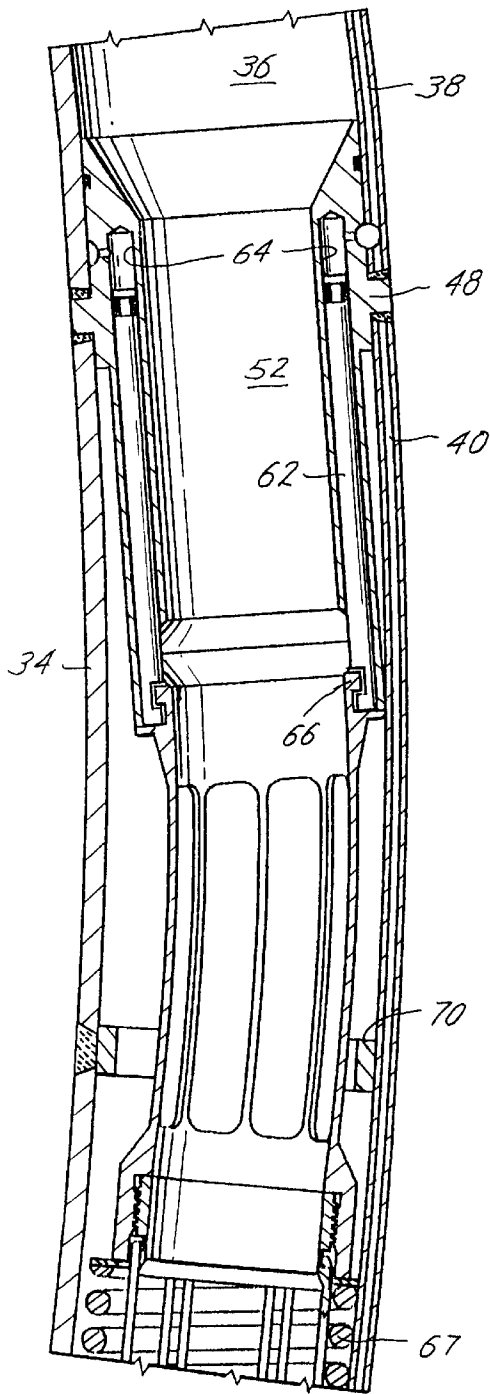
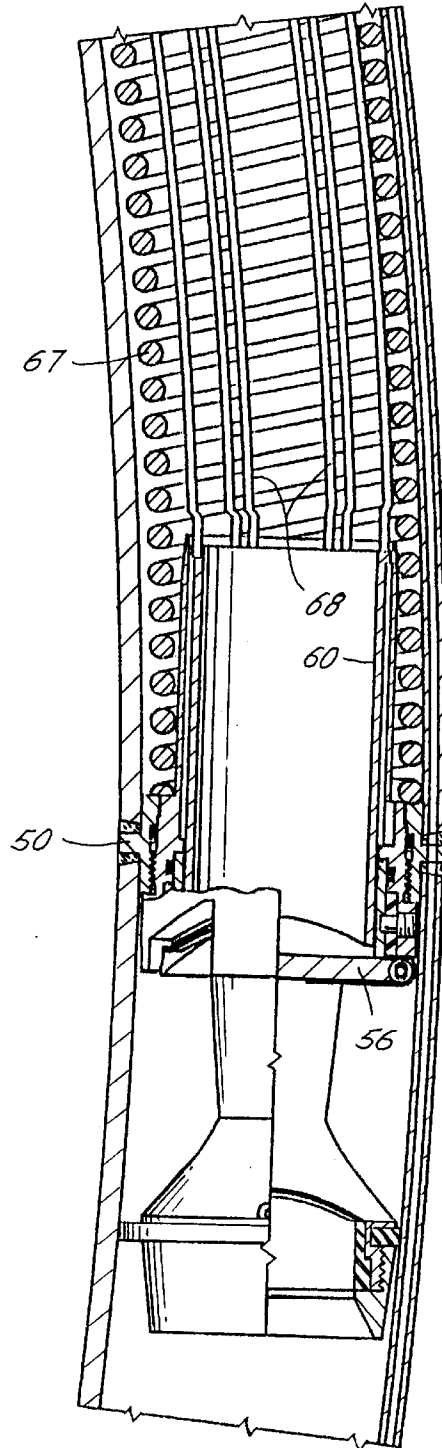
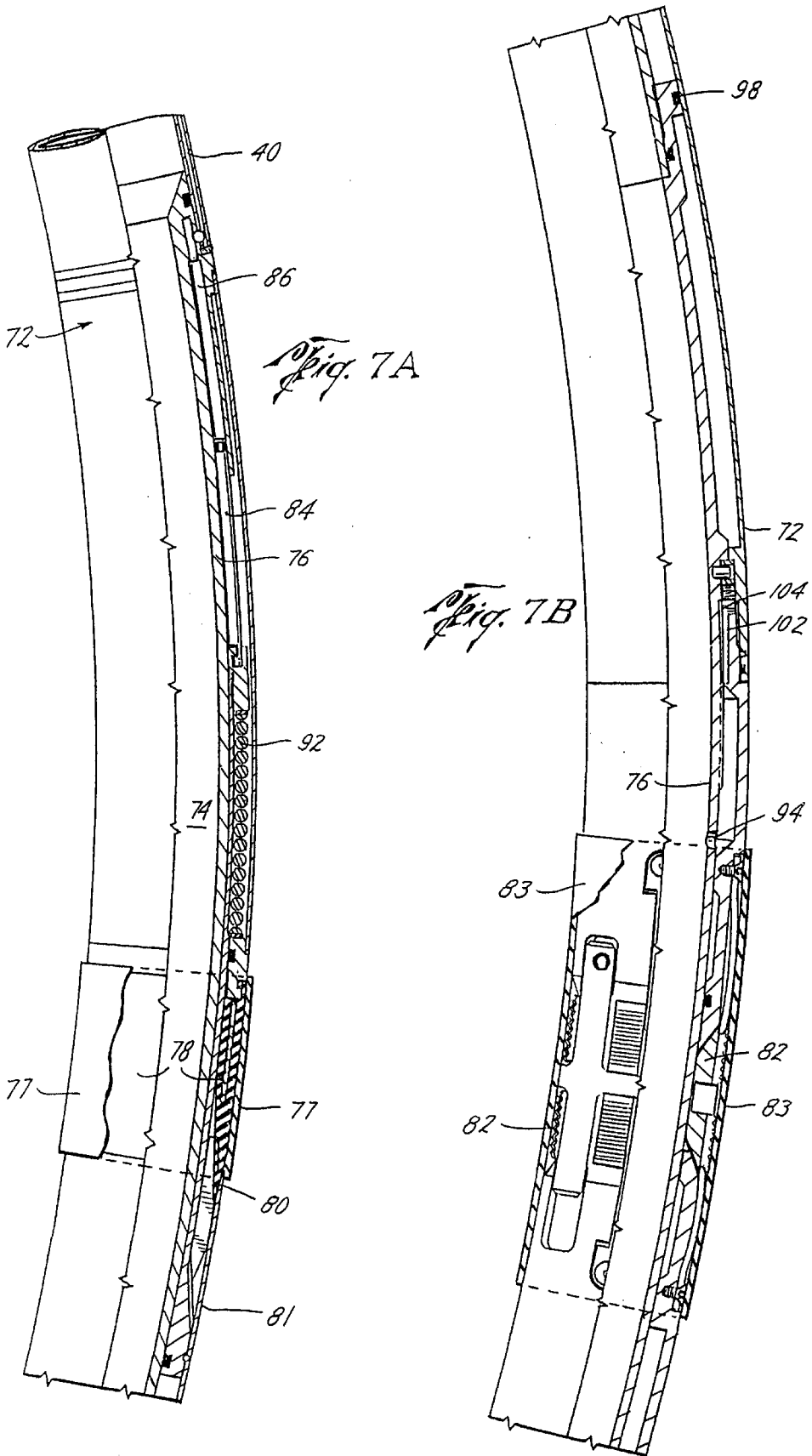

Fig. 6B





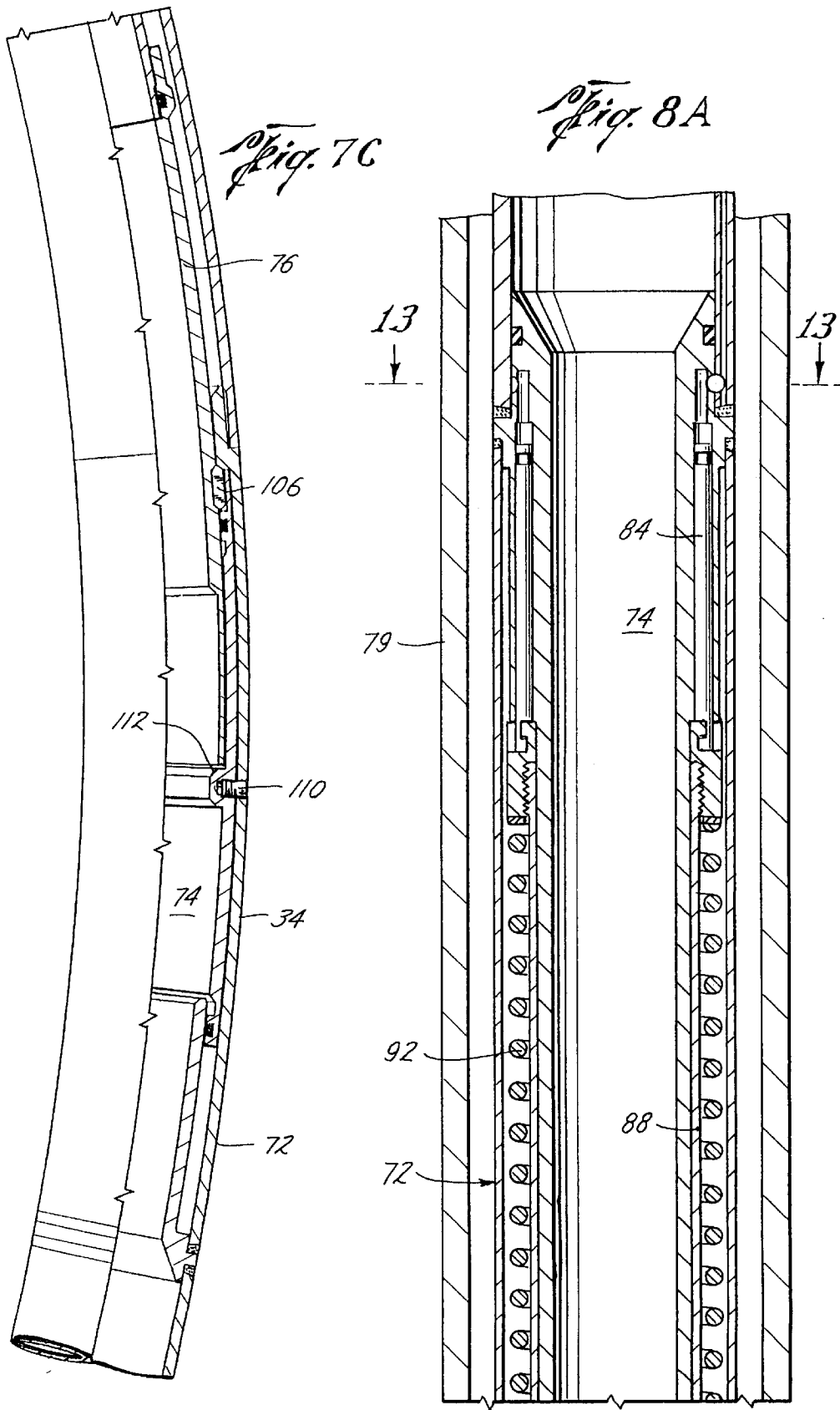

Fig. 8B

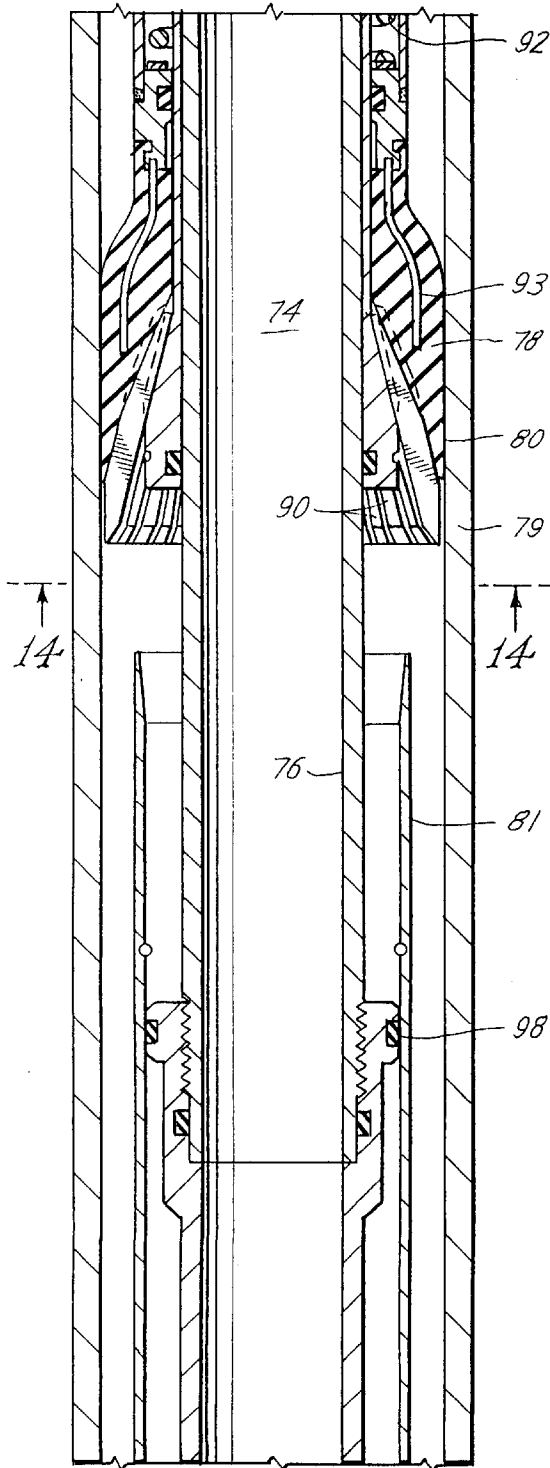

Fig. 8C

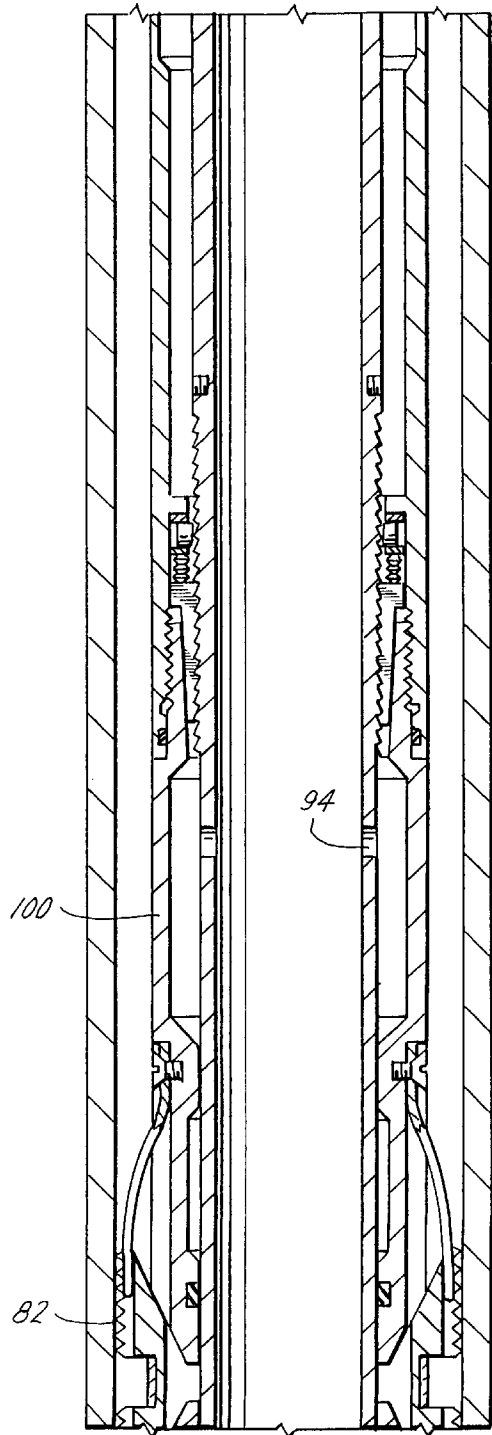

Fig. 8D

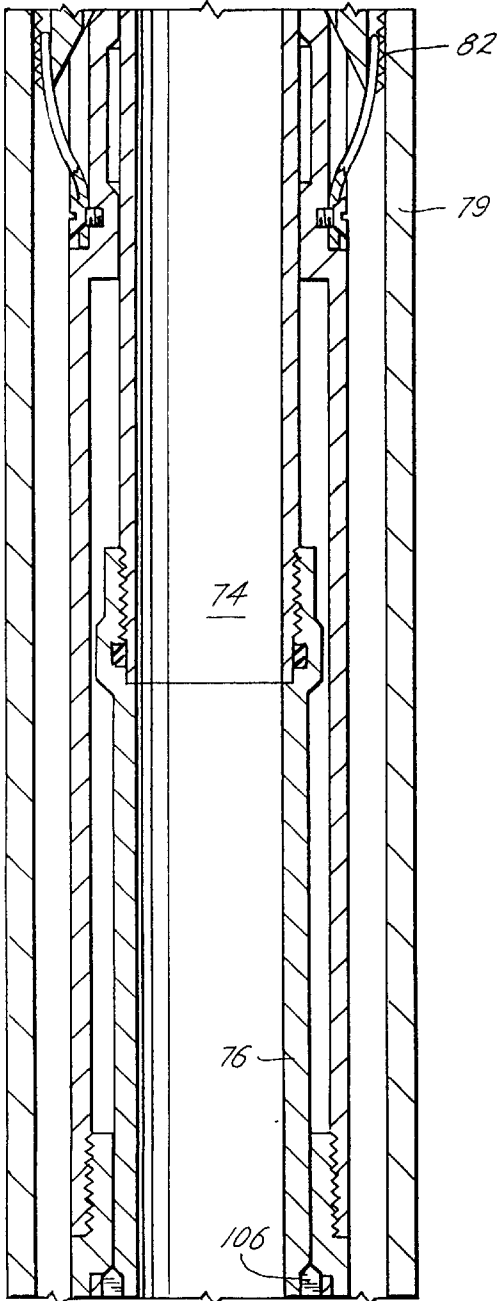

Fig. 8E

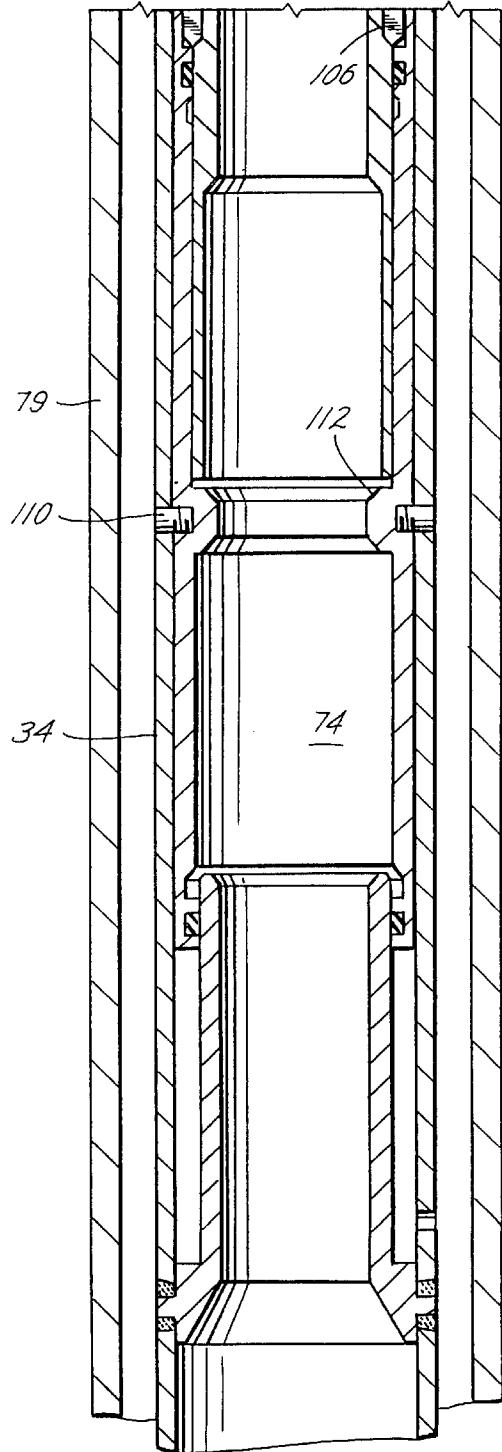

Fig. 9A

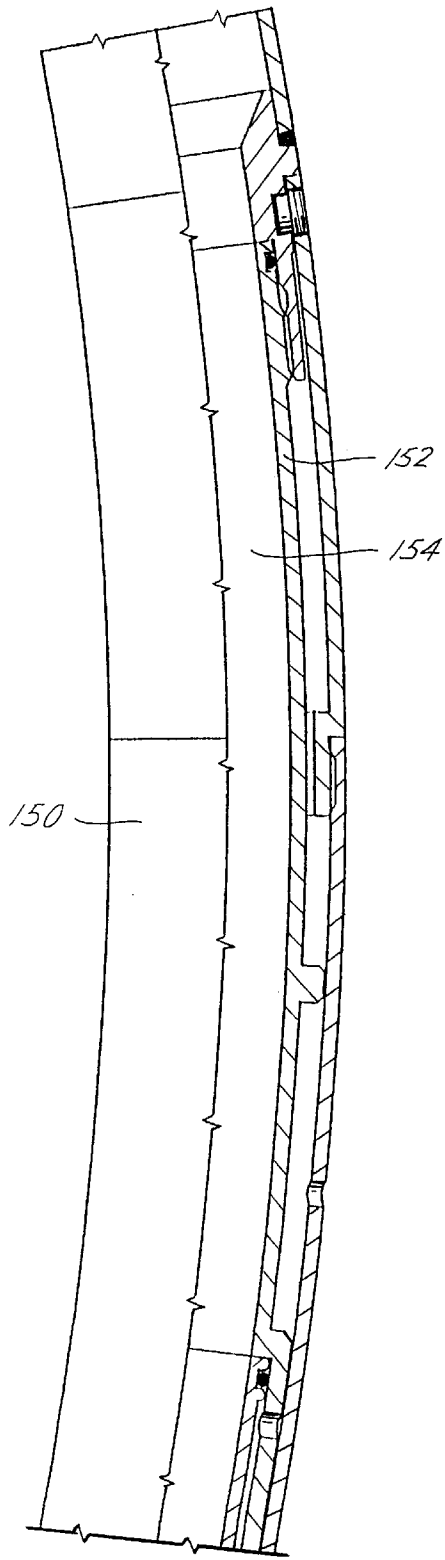

Fig. 9B

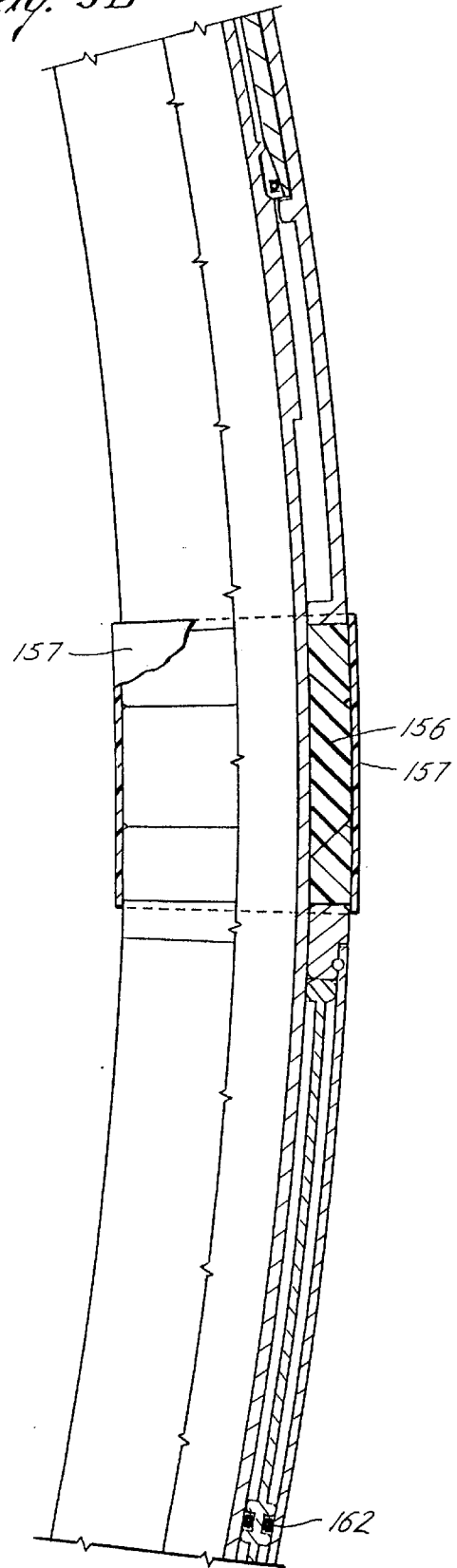

Fig. 9C

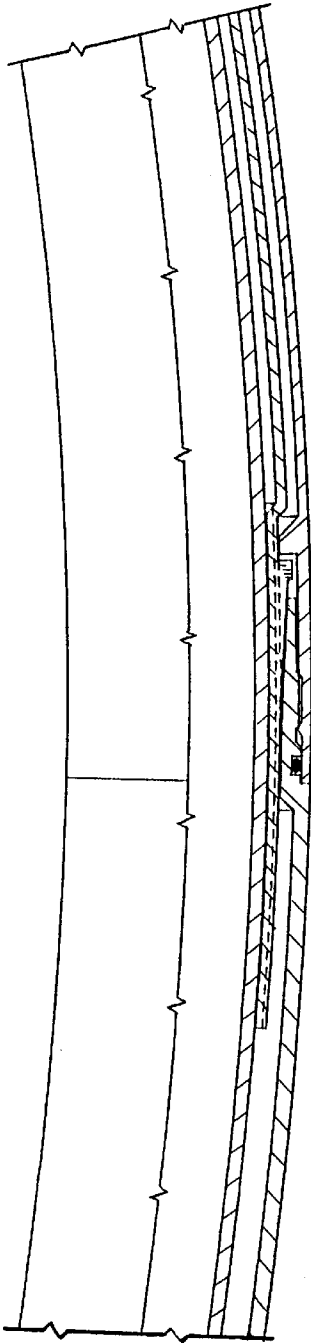

Fig. 9D

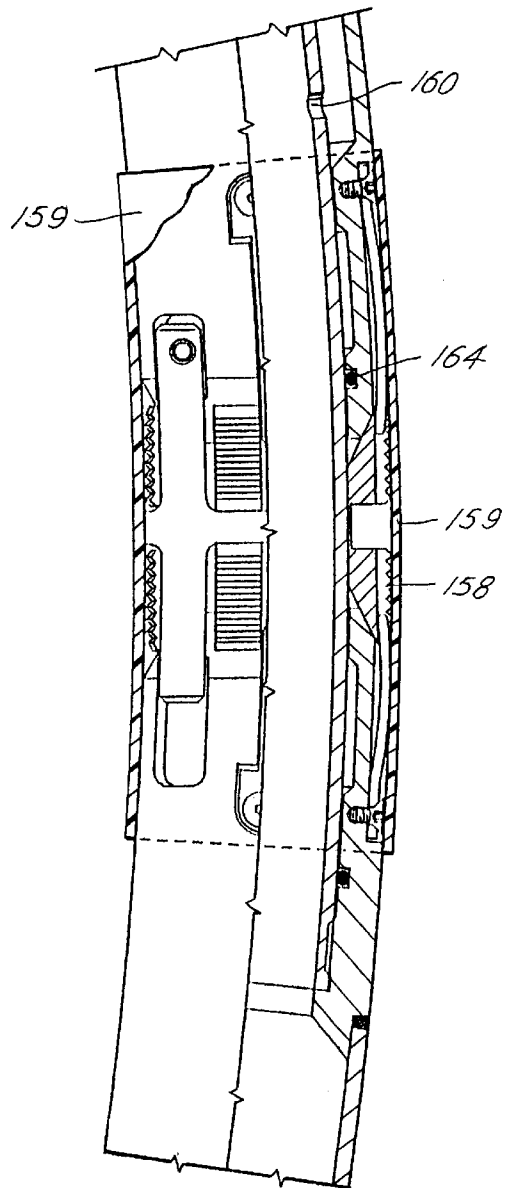

Fig. 10A

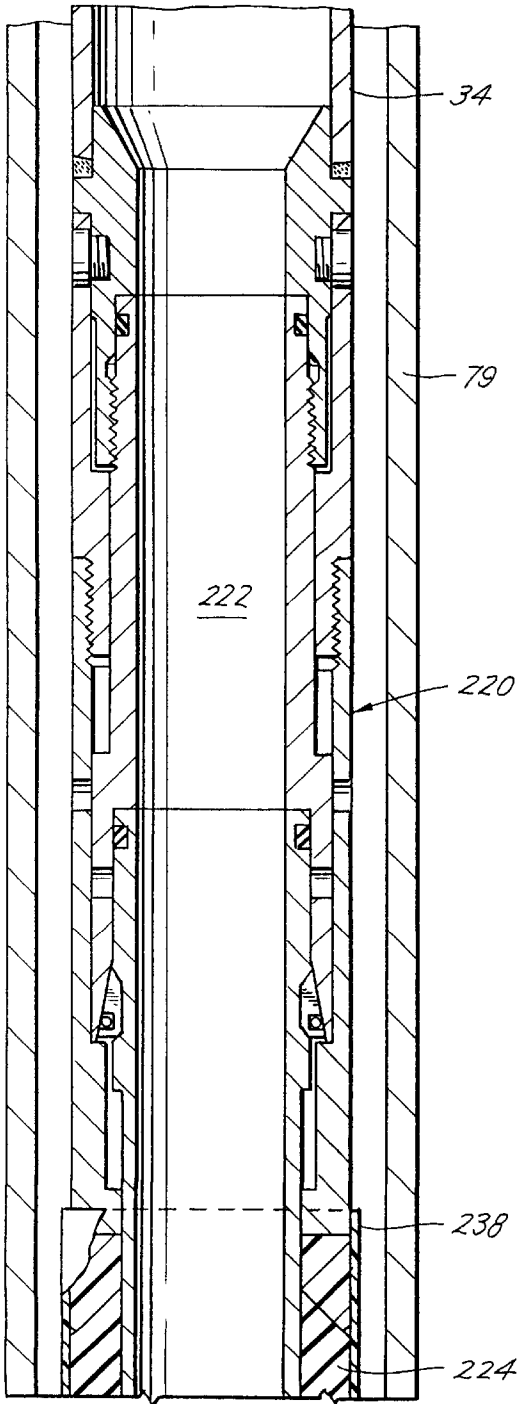

Fig. 10B

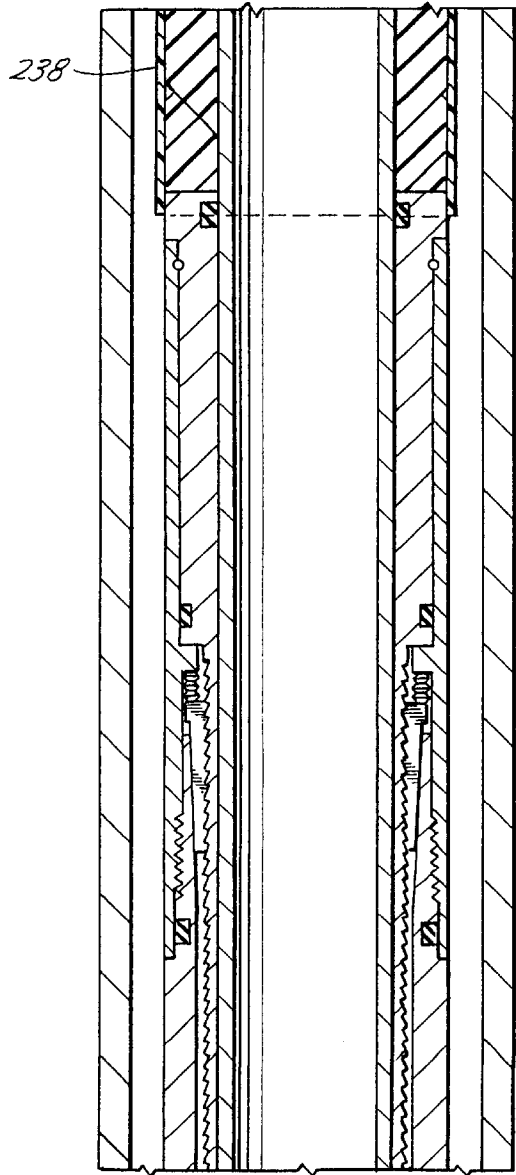

Fig. 10C

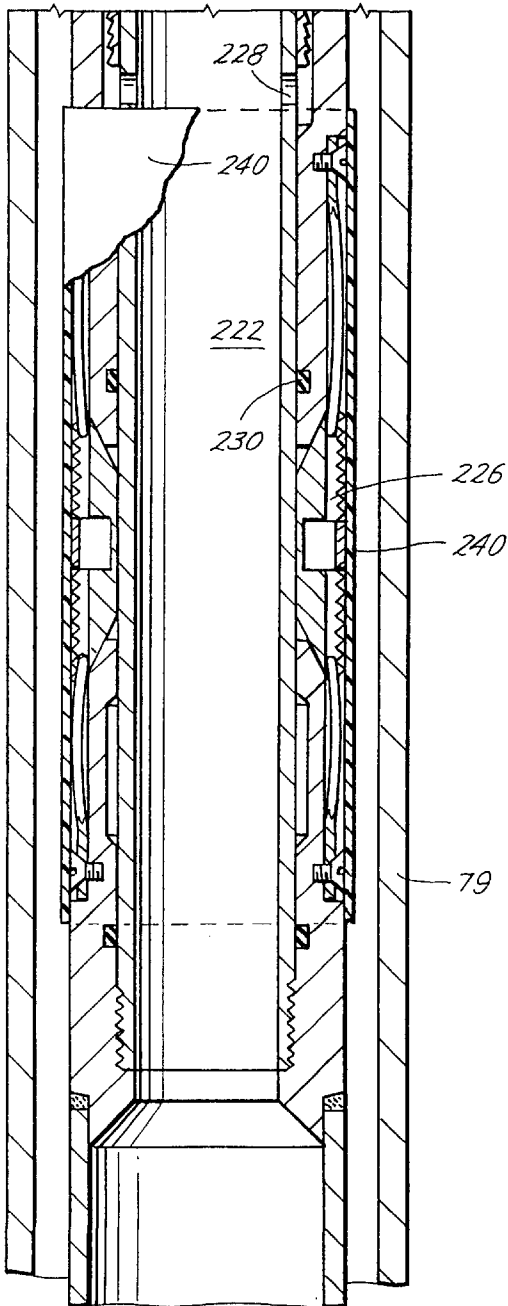

Fig. 11

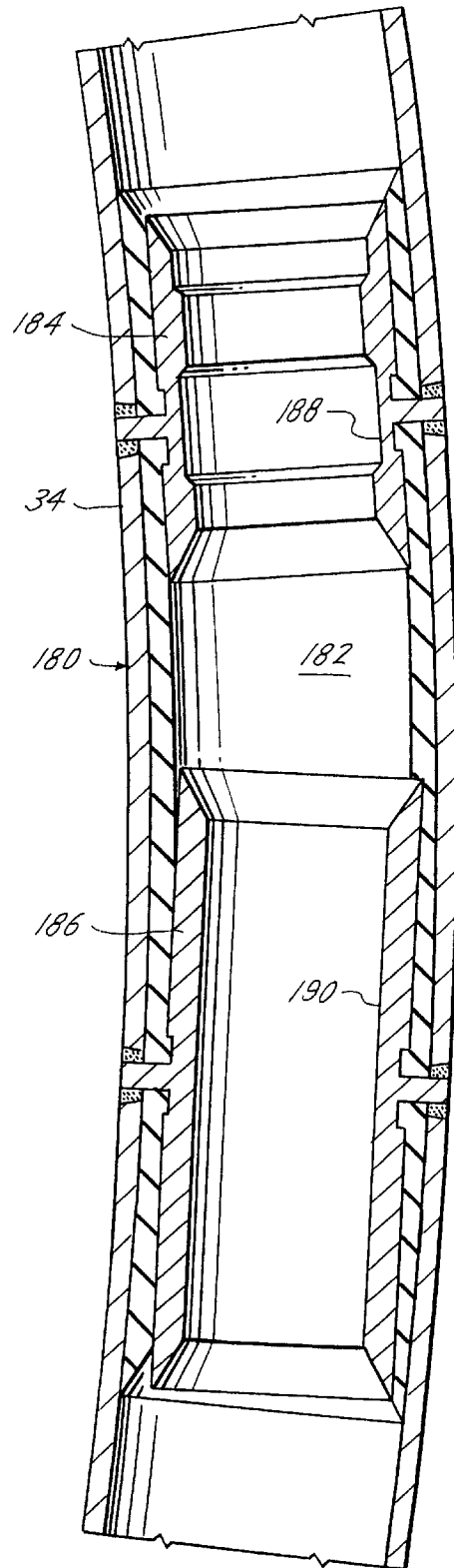

Fig. 12

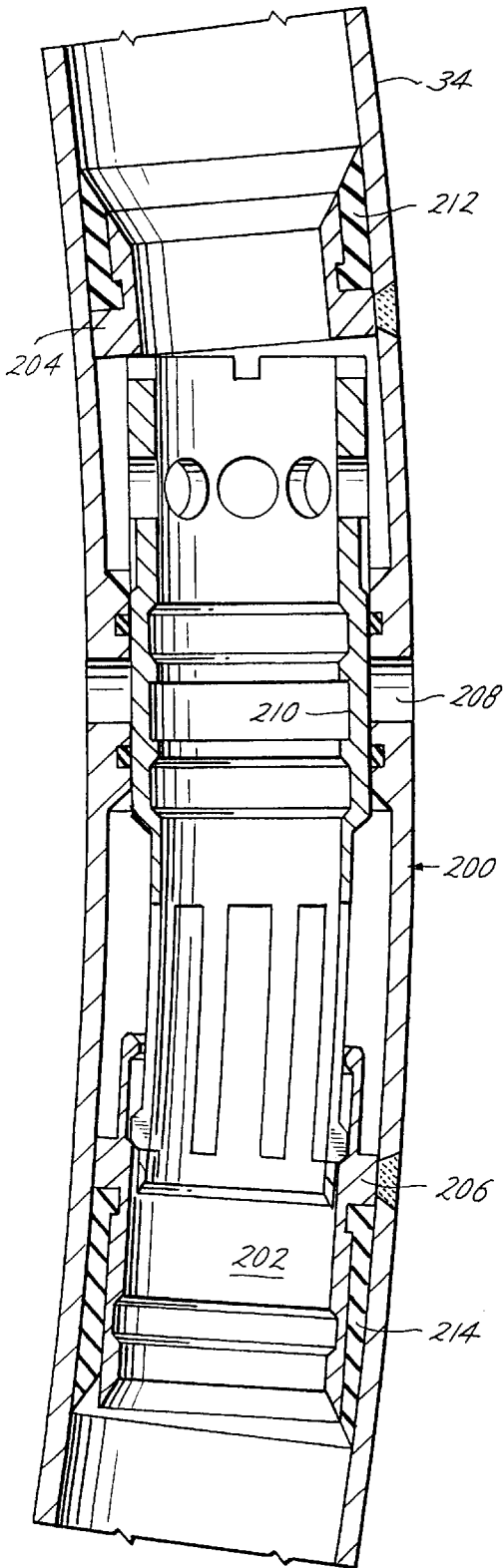

Fig. 13

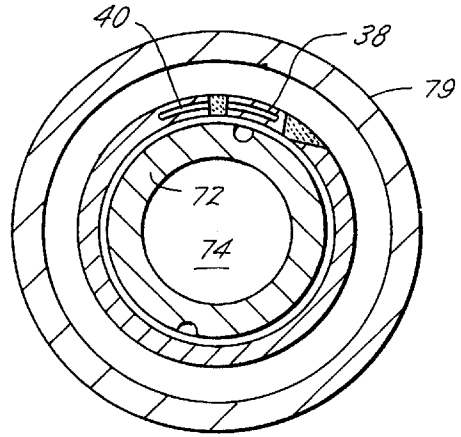
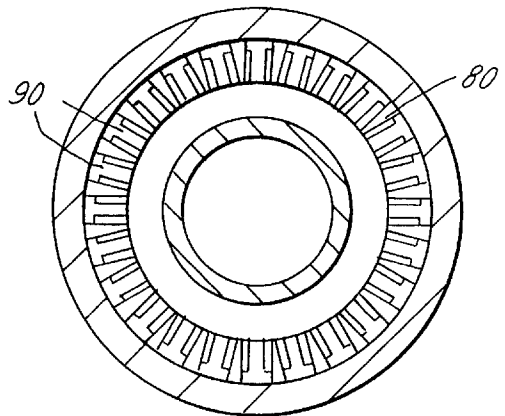

Fig. 14



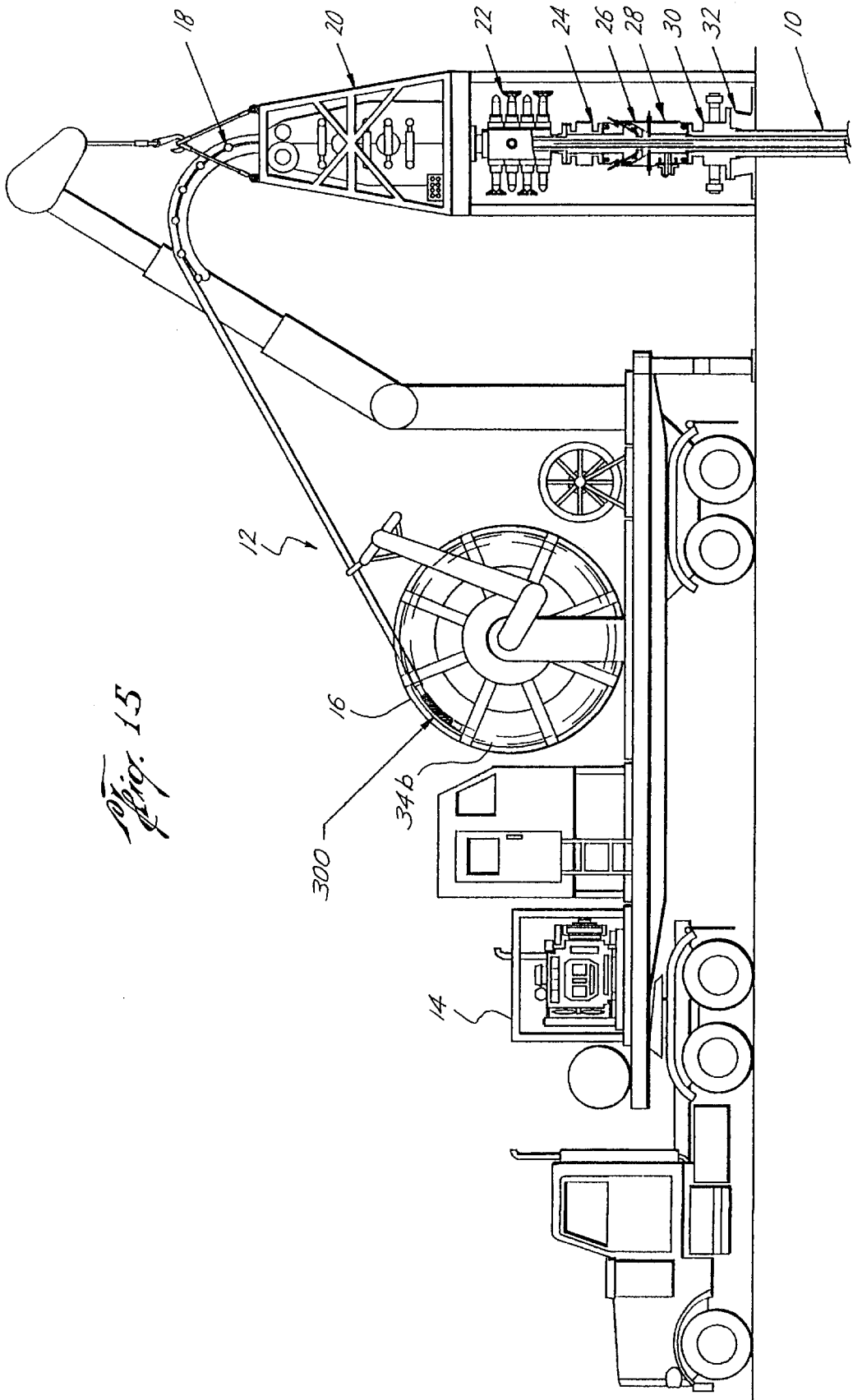
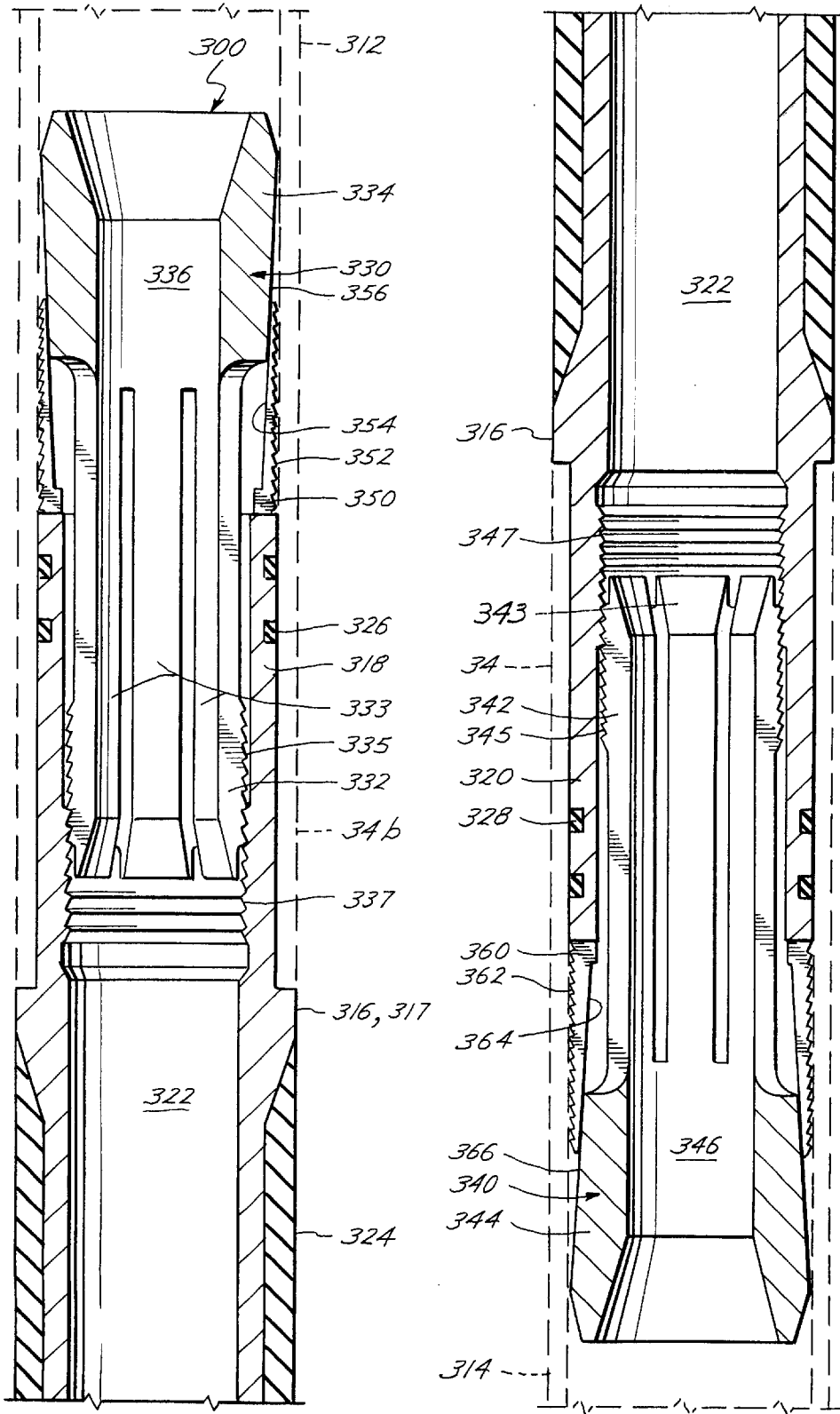

Fig. 15

Fig. 16 A

Fig. 16 B



**SPOOLABLE FLEXIBLE HYDRAULICALLY
SET, STRAIGHT PULL RELEASE WELL
PACKER**

Matter enclosed in heavy brackets [] appears in the original patent but forms no part of this reissue specification; matter printed in italics indicates the additions made by reissue.

This application is a division of application Ser. No. 08/146,344, filed Nov. 1, 1993, *now U.S. Pat. No. 5,411,085*.

BACKGROUND OF THE INVENTION

The present invention is directed to a method and apparatus for completion or recompletion of oil and/or gas wells with spoolable, flexible coiled tubing and retrieving the same.

In place of conventional drilling rigs or workover rigs, completions or recompletions of conventional oil and gas wells by coiled tubing have been disclosed in U.S. Pat. No. 4,844,166. However, the various completion equipment utilized, such as safety valves, gas lift mandrels and packers are rigid tools placed in the coiled tubing while the coiled tubing is being inserted into the well. In addition, the various completion equipment components are of a larger diameter than the coiled tubing (called upset). Since the completion equipment is rigid and has a larger outside diameter than the coiled tubing, these characteristics prevent the completion equipment from being run through a coiled tubing injector head. Therefore, equipment including windows must be provided to couple and splice this type of completion equipment in the coiled tubing string under the injector head. Furthermore, various specialized well control equipment, such as pack-offs and BOP stacks, were required because of the external upsets in the installation. Such installations were much more complicated to operate and required additional equipment when used with live wells which need to be pressure balanced.

The present invention is directed to a coiled tubing completion system which utilizes a continuous flush outside diameter length of coiled tubing and various completion components. The coiled tubing and the components are flexible and may be spooled onto a reel into lengths as long as 25,000 feet. The spool of coiled tubing and components is transported to the well site by a motorized vehicle and may be continuously injected into the well bore. As injection is occurring, a seal of well bore pressure may be more easily maintained around the circumference of the coiled tubing and components allowing the entire length to be placed in the well bore without a killing operation, eliminating the need for expensive kill fluids or damaging the formation. Included in the coiled tubing are various completion equipment, such as safety valves, annular control valves, concentric gas lift valves, packers, landing nipples, and sliding sleeves which are provided with an outside diameter flush with the coiled tubing outside diameter and which are flexible, spoolable, and with through bores large enough to pass wireline tools for various well completion operations. In addition, some of this equipment, such as safety valves and annular control valves are hydraulically operated through a hydraulic control conduit which must not be upset to the outside diameter of the coiled tubing or interfere with the through bore of the coiled tubing. The coiled tubing completion system is simplified and cost is reduced since well control equipment that is normally required for handling external upsets in a production tubing is not required.

SUMMARY

The present invention is directed to a spoolable, flexible coiled tubing completion system which includes a flexible

coiled tubing having an outer wall and a bore therethrough in which the outer wall has a continuous outer diameter without upsets and the bore is adapted to pass wireline tools. The system may include one or more of the following completion components: a longitudinally flexible safety valve, a longitudinally flexible annular control valve positioned in the coiled tubing, one or more longitudinally flexible gas lift valves positioned in the coiled tubing, a longitudinally flexible isolation packer positioned in the coiled tubing, a longitudinally flexible landing nipple positioned in the coiled tubing, a longitudinally flexible sliding sleeve positioned in the coiled tubing, a production packer and a pump out plug. All of the above include a bore therein for passage of wireline tools and have an outside diameter flushed with the outside diameter of the coiled tubing. The safety valve and annular control valve each have a hydraulic control line extending upwardly within the outer wall of the coiled tubing but adjacent the outer wall for avoiding interference with the passage of wireline tools through the coiled tubing bore.

A still further object of the present invention is the provision of a coiled tubing hanger supporting the coiled tubing, a control line housing positioned above the coiled tubing hanger for receiving the upper end of the coiled tubing and for connection to the hydraulic control lines, and an internal connector gripping means having an outside diameter no greater than the coiled tubing for longitudinal movement into the interior of the top of the coiled tubing. In one embodiment, a hydraulic control line cutting means is positioned in the control line housing for cutting any hydraulic control line. In addition, holding means may be provided in the control line hanger for holding the hydraulic control line in tension whereby any cut lines will retract in the coiled tubing and out of the way of the internal connector.

Yet a further object of the present invention is the provision of movable centralizing means in the control line housing for engaging and aligning the top of the coiled tubing for engagement by the internal connector.

Still a further object of the present invention is the provision of a coiled tubing safety valve having a housing secured to the coiled tubing, a valve closure means in the passageway moving between open and closed position for controlling the fluid flow through the passageway, a flow tube telescopically moving in the housing for controlling the movement of the valve closure member, hydraulic piston and cylinder fluid actuating means positioned above and connected to the flow tube with a biasing spring means positioned about the flow tube and connected thereto for moving the valve to a closed position. The spring means and the flow tube are longitudinally flexible for allowing bending about the longitudinal axis of the valve for allowing the valve to be spooled on a coiled tubing reel. Preferably, the hydraulic actuating means is connected to the flow tube by a flexible connection. Preferably, a downstop is connected to the inside of the coiled tubing for limiting the movement of the flow tube. In one embodiment, the coiled tubing includes a wall and a hydraulic control line is connected to the hydraulic piston and cylinder actuating means and is positioned in the wall of the coiled tubing. The longitudinally flexible valve is provided longitudinal flexibility by having a housing which includes first and second separated parts secured to the inside of the coiled tubing, and includes a plurality of separated longitudinally extending ribs.

Yet a further object of the present invention is the provision of a hydraulically controlled annular control valve having a housing with an expandable flexible cup seal having a sealing lip and positioned around the housing for

sealing between the housing and a well conduit, hydraulic piston and cylinder means for retracting the cup seal, expandable slip means positioned around the housing for gripping the interior of the well conduit and a second hydraulic piston and cylinder means for expanding the slip means. The flexible cup and the slip means are initially retracted to an outer dimension substantially equal to the outside diameter of the coiled tubing and the control valve for passing through an injector and wellhead. The control valve is longitudinally flexible for allowing bending about its longitudinal axis for allowing the valve to be spooled on a coiled tubing reel. Preferably, the annular control valve includes a longitudinally movable protector sleeve initially covering and protecting the seal lip, spring means biasing the cup seal into a fail safe expanded sealing relationship, movable wedge means for expanding the cup seal, a second spring means for biasing the cup seal toward a retracted position, and a breakable protective covering initially positioned about the cup seal and the slips.

Still a further object of the present invention is the provision of a spoolable, flexible hydraulically set, straight pull release well packer positioned in the coiled tubing and including a mandrel having a bore therethrough for the passage of wireline tools, an expandable packer seal positioned about the mandrel, expandable slip means positioned about the mandrel in which the packer seal and slip means are initially retracted to an outer dimension substantially equal to the outside diameter of the coiled tubing. Hydraulic piston and cylinder actuating means are positioned outside the mandrel and between the packer seal and the slip means for setting the slip means in the packer seal. The well packer is longitudinally flexible for allowing bending about its longitudinal axis for allowing the packer to be spooled on a coiled tubing reel. Preferably, the piston and cylinder actuating means is longitudinally flexible and a breakable protective coating is initially positioned around the packer and the slip means.

Still a further object of the present invention is the provision of a spoolable, flexible landing nipple positioned in a coiled tubing for receiving well tools which includes first and second separate spaced tubular members in which the members each have a bore extending therethrough for the passage of wireline tools. Each of the members is secured to the inside of the coiled tubing and a flexible boot is positioned between each of the members and the inside of the coiled tubing. Preferably, one of the members include a no-go shoulder and a locking recess and the other of the members includes a polished bore.

Yet a still further object of the present invention is the provision of a spoolable, flexible sliding sleeve positioned in a coiled tubing for controlling communication between the inside and the outside of the coiled tubing. The sleeve includes a tubular housing having a bore therein for the passage of wireline tools and has first and second ends connected in a coiled tubing. The housing includes at least one port for communicating between the outside and inside of the housing. A sliding tubular member telescopically moves in the housing for opening and closing the ports. An upper and lower guide is positioned on opposite sides of the member and secured to the inside of the coiled tubing, and a flexible boot is positioned between each of the guides and the inside of the coiled tubing wherein the sliding sleeve is longitudinally flexible for allowing the sliding sleeve to be spooled on a coiled tubing reel.

A still further object of the present invention is the provision of a retrievable system for retrieving a coiled tubing system having a continuous sized outside diameter

which includes a coiled tubing hanger supporting and sealing the outside of the upper end of the coiled tubing with a wellhead, a blowout preventer and an injector head successively positioned above the coiled tubing hanger, and a second coiled tubing positioned on a reel and having a first end with a longitudinally actuated internal gripping connector attached thereto for insertion through the injector, blowout preventer and wellhead and into the upper end of the first coiled tubing for gripping and removal the tubing from the well.

Yet a further object is the provision of a control line housing positioned above the coiled tubing hanger for receiving the upper end of the first coiled tubing and for connection to any hydraulic lines in the first coiled tubing. Preferably, a hydraulic control line cutting means is positioned in the control line housing for cutting any control lines for preventing the control lines from interfering with the internal gripping connector. Preferably holding means are provided in the control line hanger for holding the hydraulic control lines in tension whereby a cut line will retract in the first coiled tubing housing and out of the way of the internal connector. Preferably centralizing means are provided in the control line housing for engaging and aligning the top of the first coiled tubing for engagement by the internal connector. Preferably the centralizing means is transversely movable in relation to the longitudinal axis of the control line housing. Preferably the centralizing means includes a guide for guiding the internal connector into the top of the first coiled tubing.

Other and further objects, features and advantages will be apparent from the following description of presently preferred embodiments of the invention, given for the purpose of disclosure, and taken in conjunction with the accompanying drawings.

BRIEF DESCRIPTION OF THE DRAWINGS

FIGS. 1A, 1B, 1C, 1D, 1E, 1F, 1G, 1H, 1I, 1J, 1K, 1L, 1M, 1N, 1O, 1P, 1Q, 1R, 1S, 1T, and 1U are fragmentary elevational views, partly in cross section, and together form a spoolable coiled tubing completion system of the present invention,

FIG. 2 is a cross-sectional view taken along the line 2—2 of FIG. 1D.

FIG. 3 is a cross-sectional view taken along the line 3—3 of FIG. 1F,

FIG. 4 is a cross-sectional view taken along the line 4—4 of FIG. 1A,

FIG. 5 is a schematic elevational view, partly in cross section, of another embodiment of a control line hanger,

FIGS. 6A and 6B are elevational views, in cross section, illustrating the flexible hydraulically controlled safety valve of the present invention in a spooled and closed position,

FIGS. 7A, 7B and 7C is an elevational view, in quarter section, of the hydraulic control annular control valve of the present invention in the retracted and spooled position,

FIGS. 8A, 8B, 8C, 8D and 8E are continuations of each other and form an elevational view, in cross section, of the annular control valve of the present invention in position in a well conduit in a closed position,

FIGS. 9A, 9B, 9C and 9D are continuations of each other and form an elevational view in quarter section of the isolation packer of the present invention in a retracted and spooled position,

FIGS. 10A, 10B and 10C are continuations of each other and form an elevational view, in cross section of the production packer of the present invention in the retracted position,

5

FIG. 11 is an elevational view, in cross section, of the landing nipple of the present invention shown in the spooled position,

FIG. 12 is an elevational view, in cross section, of the sliding sleeve of the present invention shown in the spooled position,

FIG. 13 is a cross-sectional view taken along the line 13—13 of FIG. 8A,

FIG. 14 is a cross-sectional view taken along the line 14—14 of FIG. 8B,

FIG. 15 is an elevational view of a retrieval system connected to the spoolable coiled tubing completion system of the present invention, and

FIGS. 16A and 16B are continuations of each other and illustrate a suitable internal connector for retrieving the coiled tubing completion system of the present invention.

DESCRIPTION OF THE PREFERRED EMBODIMENT

While the spoolable coiled tubing completion system of the present invention will be described, for purposes of illustration only as including a tubing retrievable safety valve, an annular safety valve, one or more concentric gas lift valves, an isolation packer, a landing nipple, a sliding sleeve, a production packer and a pump out plug, many completion systems may utilize only some of this equipment depending upon the particular application.

Referring now to FIGS. 1A–1U, the spoolable coiled tubing completion system of the present invention is best seen and is referred to by the reference numeral 10 and is installed and retrieved through a retrieval system generally indicated by the reference numeral 12 (FIG. 15). The completion system 10 is installed and retrieved by the retrieval system 12 which generally includes a mobile truck and power unit 14 having a conventional coiled tubing reel 16 which inserts and removes the completion system 10 through a guide arch 18, an injector head 20, a blowout preventer 22, a wellhead or valve 24, a control line housing 26, a coiled tubing hanger 28, a tubing hanger 30, and a casing hanger 32.

As will be more fully discussed hereinafter, a completion system 10 is longitudinally flexible and can be spooled on the reel 16. All of the components have a flush diameter substantially equal to the outside diameter of the coiled tubing, but yet have a bore with a passageway therethrough for passage of wireline tools. Thus, the completion system 10 is highly advantageous as it may be inserted into and retrieved with the retrieval system 12 without requiring a window to insert or splice equipment into the coiled tubing and allows the use of standard well control equipment such as the injector head 20, the BOP 22 and any packoffs therein to control annular pressure because of the externally flushed design of the system 10. Thus, the installation of the present invention is simplified and cost reduced since well control equipment for external upsets is not required.

Referring now to FIGS. 1A, 1B and 4, a flexible coiled tubing 34 has an outer wall and a bore 36 therethrough in which the outer wall has a continuous outer diameter without upsets and the bore is adapted to pass wireline tools. The coiled tubing 34 is supported in the coiled tubing hanger 28 (FIG. 1B) and the top 37 of the coiled tubing 34 extends up into the control line hanger 26 for providing one or more hydraulic control line exits for any hydraulic control lines which are utilized in the completion system 10 such as a safety valve and annular control valve, which will be more

6

fully discussed hereinafter. The preferred embodiment is to provide two hydraulic control lines 38 and 40 within and inside the wall of the coiled tubing 34 as more fully described in patent application Ser. No. 08/142,637, filed Oct. 25, 1993, entitled "Coiled Tubing With Control Conduit And Manufacture Thereof" which is hereby incorporated by reference. The control line hanger 26 is positioned in a control line housing 27 which may include a conventional pressure test plug 29. Additionally, movable centralizing means, such as guides 42, are provided in the control line housing 27 for being transversely movable to the axis of the coiled tubing 34 for supporting the upper end 37 of the coiled tubing 34 during the retrieval process as will be more fully discussed hereinafter. Preferably, the guides 42 include inclined surfaces 44.

Referring now to FIGS. 1C, 1D and 2, a surface control subsurface spoolable hydraulic control longitudinally flexible safety valve is generally indicated by the reference numeral 46 having a housing which includes first 48 and second 50 separated parts each of which is secured to the inside of the coiled tubing 34 and which forms part of the housing of the safety valve 46 and thus presents a flush exterior with the remainder of the coiled tubing 34 without requiring any upsets. The valve 46 generally includes a bore 52 therethrough for the passage of wireline tools, an annular valve seat 54, a valve closure element or flapper valve 56 connected to the housing by pivot pin 58, a flow tube 60 is telescopically movable in the housing through the valve seat 54 to move the flapper 56 to the open position as best seen in FIG. 1D. When the flow tube 60 is moved upwardly; the flapper 56 is allowed to move upwardly onto the seat 54. Hydraulic piston and cylinder actuating means such as one or more pistons 62 and cylinders 64 in communication with hydraulic conduit 38 are positioned above and connected to the flow tube 60 by a flexible connection 66, such as a loose tongue and groove connection, for moving the flow tube 60 downwardly and opening the valve 46. A biasing spring 67 is positioned about the flow tube 60 and connected thereto for moving the flow tube 60 upwardly and into a fail safe closed position. The spring 67 and the flow tube 60 are longitudinally flexible for allowing bending about the longitudinal axis of the valve for allowing the valve to be spooled onto a coiled tubing reel. Preferably, the flow tube 60 includes a plurality of separated longitudinally extending ribs 68 for providing longitudinal flexibility. In addition, the valve 46 includes a down stop 70 positioned to engage a stop on the flow tube 60 for preventing excessive column loading in the safety valve 46. Referring now to FIGS. 6A and 6B, the safety valve 46 is shown in the closed and spooled condition.

Referring now to FIGS. 1E, 1F, 1G, 1H and 1I, a surface control subsurface annular control safety valve which is longitudinally flexible, spoolable and hydraulically controlled is positioned in the coiled tubing 34 and has a bore 74 therein for passage of wireline tools. The valve 72 includes a housing 76 having an outside diameter substantially equal to the outside diameter of the coiled tubing 34. The valve 72 includes an expandable, flexible cup seal 78 having a sealing lip 80 and is positioned around the housing 76 for sealing between the housing 76 and a well conduit 79 which may be production tubing or well casing. The valve 72 also includes slips 82 outside of the housing 76.

As best seen in FIGS. 7A, 7B and 7C, the annular control valve 72 is longitudinally flexible and the expandable cup seal 78 and the slips 82 are initially in a retracted position whereby the outside diameter of the valve 72 is substantially the same as the outside diameter of the coiled tubing 34

whereby the valve 72 may be inserted through the retrieval system 12. Preferably, the outside of the cup seal 78 is sealed with a thin breakable protective cover such as a heat shrinkable plastic 77, such as sold under the trademark "Teflon" and the slips 82 are initially sealed with a thin breakable protective covering such as room temperature vulcanized rubber 83. The protective covers on the seal 78 and the slips 82 are for protecting these elements from components in the system 12 and also protecting any seals in the system 12 from the valve 72. However, after installation in the well, the protective covers, which are breakable, are broken on expansion of the seal 78 and slips 82. Additionally, a longitudinally movable protective sleeve 81 initially covers and protects the sealing lip 80 as it is passed downwardly through the system 12 and into the well.

Referring again to FIGS. 1E and 1F, hydraulic piston and cylinder means, such as one or more pistons 84, are movable in cylinders 86 and in communication with hydraulic control conduit 40. The hydraulic control means are connected by a sleeve 88 to a plurality of wedges 90 (FIGS. 1F and 3). Spring biasing means 92 normally biases the piston and cylinder assembly upwardly moving the sleeve 88 and the wedges 90 upwardly to expand the lip seal 80 against the interior of the well conduit 94, as best seen in FIGS. 8A-8E (after setting the slips). Actuation of the hydraulic piston and cylinder assemblies 84, and 86 moves the wedges 90 downwardly and allows the flexible cup seal, which may be rubber, to retract by the action of springs 93 embedded in the flexible cup seal 78. As best seen in FIG. 1F, with the cup seal 78 in the retracted position, lift gas may be injected down the annulus between the annular control valve 72 and the inside of the well conduit 79 to downhole gas lift valves which will be more fully discussed hereinafter. And the annulus provides a much greater gas flow area than conventional annular control valves. However, actuation of the flexible cup 78 to the expanded position (FIG. 8B) packs off and seals the annulus between the valve 72 and the inside of the well conduit 79. And the lip 80 is pressed into an increasing sealing relationship with the inside of the well conduit 79 as the annulus pressure therebelow increases.

Prior to expanding the cup seal 78, the slips 82 are expanded and set. Referring now to FIGS. 1F, 1G and 1H, hydraulic pressure is exerted through the bore 74 of the control valve 72 (as will be more fully explained hereinafter through a pump out plug) and hydraulic fluid is exerted through ports 94 (FIG. 1G) between seals 96 (1G) and 98 (1F) to move element 100 downwardly which (1) moves the protective sleeve 81 downwardly away from the lip 80 of the cup seal 78 and wedges the slips 82 outwardly against the inside wall of the well conduit 79. This sets the slips 82 which are then held in a set position by ratchet 102 on the member 100 acting against ratchet teeth 104 on the housing 76.

The annular control valve 72 includes mechanically actuated releasing means for releasing the control valve 72 from the inside of the well conduit 74. Referring to FIGS. 1H and 1I, the interior housing 76 of the valve 72 is connected through dogs 106 to the coiled tubing 34. A sleeve 108 which holds the dogs 106 in place is connected to the coiled tubing 34 by shear pins 110. The sleeve 108 includes an upwardly facing shoulder 112 which, when jarred by a suitable tool, shears the pins 110, moves the sleeve 108 downwardly, and releases the dogs for allowing the control valve 78 to be lifted and the slips 82 retracted.

Referring now to FIGS. 1J, a longitudinally flexible gas lift valve 120 is shown connected in the coiled tubing 34. In the completion system 10, normally a plurality of such gas

lift valves may be provided. The gas lift valve 120 is more fully disclosed in patent application Ser. No. 08/115623, filed Sep. 3, 1993, entitled "Coiled Tubing Concentric Gas Lift Assembly", and such disclosure is incorporated herein by reference. The gas lift valve 120 has an outside diameter equal to the outside diameter of the coiled tubing 34, and includes a bore 122 for passage of wireline tools and is longitudinally flexible. Generally, the gas lift valve 120 includes a housing 124 which includes one or more ports 126 for the admission of gas in the annulus outside of the housing 12 which is injected into the bore 122 for lifting fluids therein. The valve 120 is normally biased to a closed position by a gas charged compartment 128 acting on one or more bellows 130 and 132. The gas compartment 128 is charged through a dill valve 134. A movable ball 136 and a seat 138 are provided in the housing 124 in communication with the port 126. The gas charged compartment 128 acts to seat the ball 136 on the seat 138 by being connected to a valve element extension 140. For opening the valve 120, lifting gas is injected into the port 126, lifts the ball element 136 and allows the gas to pass into the bore 122.

Referring now to FIGS. 1K, 1L, 1M, 1N and 1O, a zone or isolation packer 150 is shown. The packer 150 is shown in the set position in FIGS. 1K-1O. The packer 150 is shown in its spooled and retracted position in FIGS. 9A-9D. The packer 150 includes a housing 152 connected to the inside of the coiled tubing 34 in which the coiled tubing forms part of the housing for the packer 150. As best seen in FIGS. 9A-9D, the packer 150 in its retracted position has an outside diameter equal to the outside diameter of the coiled tubing 34 and thus does not create any upsets. The packer 150 also includes a bore 154 where passage of wireline tools. The packer 150 includes conventional seal means 156 which may be a conventional wire mesh and resilient seal and also includes slip means 158. The seal means 156 and slip means 158 are adapted to expand and engage against the inside of the well conduit 79. Preferably, the seal means 156 includes a thin breakable protective coating 157 such as a heat shrinkable plastic such as one sold under the trademark "Teflon". And the slips 158 include a thin breakable protective coating 159 such as room temperature vulcanized rubber. The coatings 157 and 159 are to protect the seal 156 and the slips 158 as they are moved into the well and also protect any seals in the system 12. Thereafter, the protective coatings 157 and 159 will be broken when the seal means 156 and the slip means 158 are expanded into a set position.

The packer 150 is a hydraulic set straight pull release packer. The packer 150 is set by pressuring up hydraulic fluid in the bore 154 and applying this pressurizing fluid in through ports 160 in FIG. 1N which act between piston seals 162 (FIG. 1O) and seal 164 (FIG. 1M). This causes movement of the wedges 166 for extending the slips 158 into engagement with the well conduit 79 and thereafter compressing the seal means 156 into the set position of FIG. 1L. The seal means 156 and the slip means 158 are held in the set position by a ratchet 166 coating with ratchet teeth 168. As shown in FIGS. 9A-9D, the packer 150 is longitudinally flexible for allowing bending about the longitudinal axis of the well packer 150 for allowing the packer 150 to be spooled on a coiled tubing reel. The piston seals 162 and 164 form pistons movable in their respective cylinders between the seal means 156 and the slip means 158 and are longitudinally flexible for assisting in bending of the packer 150. The packer 150 includes shear pins 170 (FIG. 1K) for releasing the seal means 156 and the slip means 158 on an upward pull of the coiled tubing 34 when it is desired to pull the completion system 10 from the well conduit 79.

Referring now to FIG. 1P, the reference numeral **180** refers to a longitudinally flexible landing nipple positioned in the coiled tubing **34** and having a bore **182** therein for the passage of wireline tools. The landing nipple **180** is shown in a spoolable position in FIG. 11 for storage on a coiled tubing reel. The landing nipple **180** includes first **184** and second **186** separate and spaced tubular members each having a bore extending therethrough for the passage of the wireline tools. The members **184** and **186** are secured to the inside of the coiled tubing **34**, such as by welding, and therefore the members **184** and **186** along with a section of the coiled tubing **34** form a housing for the nipple **180**. Therefore, the exterior of the landing nipple **180** is flush with the coiled tubing **34**. The part **184** may include a no-go shoulder **187** and a locking recess **188** and the second part **186** may include a polished bore **190**. Thus, the interior of the landing nipple **180** is similar to that of a conventional D nipple of Camco International Inc. However, by providing separate members **184** and **186** the landing nipple **180** may be made longitudinally flexible and in addition the members **184** and **186** may be separated from each other by variable lengths to accommodate various types of other well tools. In addition, a flexible boot **192** is positioned between each of the members **184** and **186** and the inside of the coiled tubing **34** for providing flexibility and provide barriers at each end of the members **184** and **186** for preventing wireline tool hangups.

Referring now to FIG. 1Q, a spoolable longitudinally flexible sliding sleeve **200** is best seen positioned in the coiled tubing **34** and having a bore **202** therein for the passage of wireline tools. The sliding sleeve **200** has a housing including a portion of the coiled tubing **34**, a first end **204**, and a second end **206** connected to the coiled tubing **34**. The housing includes one or more ports **208** for communicating fluid between the outside and the inside of the housing. The sliding sleeve **200** is shown in the spooled and flexed position in FIG. 12.

A sliding tubular member **210** is telescopically movable in the housing for opening and closing the ports **208**. The ends **204** and **206** are positioned on opposite ends of the tubular member **210**. A flexible boot **212** and **214** is positioned between each of the ends **204** and **206**, respectively, and the inside of the coiled tubing **34** whereby the sliding sleeve **200** is longitudinally flexible for allowing the sliding sleeve **200** to be spooled on a coiled tubing reel.

Referring now to FIGS. 1R, 1S and 1T, a production packer **220** is illustrated in the set position and is shown in the set position in FIGS. 10A, 10B and 10C. The production packer **220** includes a bore **222** therethrough for the passage of wireline tools and the packer, in the retracted position, as best seen in FIGS. 10A, 10C includes an outside diameter flush with the outside diameter of the coiled tubing **34**. While the packer **220** is positioned in the coiled tubing **34**, it is connected adjacent the lower end of the completion system **10** and therefore is not required to be longitudinally flexible when the completion system **10** is rolled upon a coiled tubing reel. However, it is important that the packer **220** have a flush OD for passing through the injector head, packoff and blowout preventer and yet have a bore size for passage of other wireline tools. The packer **220** is similar in structure and operation to the isolation packer **150** previously described and is hydraulically set and mechanically released with a straight pull. Thus, the packer **220** includes packing sealing means **224** and slips **226**. The packer **220** is set by pressuring up fluid in the bore **222** and applying it through a port **228** to act across seals **230** and **232** to actuate the slip means **226** and the seal means **224**. The packer **220**

is then held in the set position by the action of a ratchet **234** acting against teeth **236**. A thin breakable protective coating **238**, such as a heat shrinkable plastic, such as sold under the trademark "Teflon", is applied around the seal **224**. And a thin breakable protective coating **240**, such as a room temperature vulcanized rubber, is applied around the slip means **226**.

Referring now to FIG. 1U, a pump out plug **250** is connected to the lower end of the coiled tubing **34** and includes a bore **252** therethrough for the passage of wireline tools. The pump out plug **250** includes an outside diameter substantially equal to the outside diameter of the coiled tubing **34**, but the pump out plug **250** is used to pressurize the bore of the tubing completion system **10** by dropping a ball **254** onto a removable seat **256**. In addition, the pump out plug **250** may include a no-go shoulder **258** and a locking recess **260** for landing additional well tools therein.

Referring now to FIG. 5, another embodiment of a control line hanger and control line housing is shown as a variation of the embodiment illustrated in FIG. 1A. Like parts to that shown in FIG. 1A are similarly numbered with the addition of the suffix "a". In FIG. 1A, the hydraulic control conduits **38** and **40** were illustrated as being within the walls of the coiled tubing **34**. However, in some installations the control conduit or conduits may be positioned on the inside of the coiled tubing **34a**. Such an internal type hydraulic control conduit would interfere with the operation of the retrieval system **12** which will be more fully discussed hereinafter which grips the inside of the top **37a** of the coiled tubing **34a**. Thus, a control line hanger **26a** is positioned in a control line hanger housing **27a** in which one or more hydraulic control conduits, here shown as a single hydraulic conduit **38a** extends down the interior of the coiled tubing **34a**. The control line hanger **26a** holds the control line **38a** in tension, such as an inverted U configuration, and the control conduit **38a** is shown exiting the housing **27a**. The hanger **26a** includes a cutting means **39** which, when actuated, such as hydraulically cuts the control conduit **38a** which is under tension, and thus conduit **38a** springs back into the interior of the coiled tubing **34a** and below the top **37a**. This clears the inside of the top of the coiled tubing **34a** for retrieval operations. Additionally, the control line housing **27a** includes movable centralizing guides **42a** having guide surfaces **44a** for moving inwardly against the outside of the top **37a** of the coiled tubing **34a** for centralizing the coiled tubing **34a** for insertion of the retrieval system **12**.

Referring now to FIGS. 15, 16A and 16B, a system for retrieving the spoolable completion system **10** of the present invention is best seen. Because the tubing completion system **10** has a flush and constant outside diameter without any upsets and is flexible and spoolable, the retrieval system **12** is able to retrieve the tubing system **10** through the injector **20**, the blowout preventer **22** and the wellhead **24** and any other packoffs even if the well is live without needing to pressure balance the well as the completion system **10** is removed. The retrieval system **12** includes the reel **16**, and a second coiled tubing **34b** positioned on the reel **16** having at its end a longitudinally actuated internal gripping connector **300** which is longitudinally flexible and has an outside diameter equal to the outside diameter of the coiled tubing so that it may be inserted through the injector **20**, the blowout preventer **22** and the wellhead **24** and into the upper end **37** or **37a** of the coiled tubing **34** or **34a** for gripping and removing the completion system **10** from the well. The internal connector **300** may be of the type disclosed in patent application Ser. No. 08/013,385, filed Feb. 4, 1993, entitled "Method And Apparatus For Internally Connecting To

Coiled Tubing”, which is incorporated herein by reference. Generally, the connector **300**, as shown in FIGS. **16A** and **16B**, is initially positioned, but unset, in the inside of one end of the coiled tubing **34b** and **34**, shown in dotted outline. The connector **300** includes a metal body **316** having a first end **318** and a second end **320** and a bore **322** therethrough for the passage of fluids. The body **316** has an outside diameter **324** of a size no greater than the outside diameter of the coiled tubing **34b** and **34**. Therefore, the body **316** does not upset or protrude past the outside diameter of the coiled tubing **34b** and **34** and thus passes freely through coiled tubing injector chains, round goosenecks, and on to the coiled tubing reel **16**. The first end **318** of the body **316** and the second end **320** of the body **316** have an outside diameter substantially equal to the inside diameter of the first and second coiled tubing **34b** and **34**, respectively.

Seal means, such as O-ring seals **326** and **328** are provided on the first end **318** of the body **316** and also on the second end **320** of the body **316**, respectively, for sealing between the first end **318** and the inside of the first coiled tubing **34b** and for sealing between the second end **320** of the body **316** and the inside of the second coiled tubing **34**, respectively.

In the preferred embodiment, the outside diameter of the metal part of the body **316** is substantially equal to the inside diameter of the coiled tubing **34b** and **34** which allows the body **316** to be thin and flexible and spoolable. A plastic coating **324**, such as sold under the trademark “Halar 200” is bonded to the exterior of the body **316**. The coating **324** has an outside diameter substantially equal to the outside diameter of the coiled tubing **34b** and **34**.

A first mandrel **330** has a first end **332** and a second end **334** and is provided with a bore **336** therethrough in communication with the bore **322**. The first end **332** of the first mandrel **330** includes a plurality of collet fingers **333** and coating ratchet means on the fingers and the inside of the first end **318** of the body **316**. Thus, the collet fingers **333** include a plurality of ratchet teeth **335** which coat with ratchet teeth **337** on the inside of the body **316**. Thus, the mandrel **330** may ratchet into the bore **322** of the body **316** but cannot longitudinally move out of the body **316**. A second mandrel **340** includes a first end **342** and a second end **344** with a bore **346** therebetween in communication with the bore **322**. The first end **342** of the mandrel **340** includes a plurality of collet fingers **343**. Coating ratchet means are provided on the outside of the fingers **343** and on the inside of the second end **320** of the body **316**. Thus, ratchet teeth **345** are provided on the exterior of the collet fingers **343** and teeth **347** on the inside of the body **316**. Preferably, the teeth **345** and **347** are coating threads. Therefore, the mandrels **330** and **340** may longitudinally move towards the body **316**, but are prevented from moving away from the body **316** by the coating ratchet teeth.

First slip means **350** abuts the first end **318** of the body **316** and is engagable with the outside of the first mandrel **330**. The slip means **350** includes a plurality of outwardly directed teeth **352** which are preferably directed towards the first end **318** of the body **312** and towards the end of the first coiled tubing **312**. A second slip means **360** is provided abutting the second end **320** of the body **316** and is engagable with the outside of the second mandrel **340**. The slip means **360** includes a plurality of outwardly directed teeth **362** directed towards the end **320** of the body **316** and towards the end of the coiled tubing **314**. Thus, it is noted that when the slips **350** and **352** are inserted into the coiled tubings **312** and **314**, respectively, the slip means **350** and **352** travels into the ends of the coiled tubings **312** and **314**, but not out of the ends of the coiled tubing **312** and **314**.

Coating wedge surfaces are provided on the inside of the first slip means **350** and on the outside of the first mandrel **330** such as wedge surface **354** on the slip means **350** and wedge surface **356** on the outside of the mandrel **330**. The wedge surfaces **354** and **356** wedge the first slip means **350** into the inside of the first coiled tubing **312** when the body **316** is longitudinally pulled out of the end of the coiled tubing **312** thereby pulling the mandrel **330** by the coating engaging ratchet teeth **335** and **337**. Similarly, second coating wedge surfaces are provided on the inside of the second slip means **360** and the outside of the second mandrel **340** such as wedge surface **364** on the inside of slip means **360** and wedge surface **366** on the outside of mandrel **340** for wedging the second slip means **360** into the inside of the second coiled tubing **314** when the body is longitudinally pulled out of the second coiled tubing **314**.

In use, the connector **300** is made up as best seen in FIGS. **16A** and **16B**. A longitudinal pull is exerted on the coiled tubing **34b** in a direction to withdraw the body **300** from the ends of the coiled tubing **34b** and **34**. The longitudinal force is alternated to provide a compressive force to allow the connector **300** to longitudinally ratchet together to securely grip the insides of the coiled tubings **34b** and **34**. After securing the connector **300** to the coiled tubings, the spoolable completion system **10** may be removed (after the packers **150** and **220** are unseated) and withdrawn from the well.

The present invention, therefore, is well adapted to carry out the objects and attain the ends and advantages mentioned as well as others inherent therein. While a presently preferred embodiment of the invention has been given for the purpose of disclosure, numerous changes in the details of construction, will be readily apparent to those skilled in the art and which are encompassed within the spirit of the invention and the scope of the appended claims.

What is claimed is:

1. A spoolable flexible hydraulically set, straight pull release well packer positioned in a coiled tubing comprising,
 - a mandrel having a bore therethrough for the passage of wireline tools,
 - an expandable packer seal positioned about the mandrel
 - expandable slip means positioned about the mandrel,
 - said packer seal and said slip means being initially retracted to an outer dimension substantially equal to the outside diameter of the coiled tubing,
 - hydraulic piston and cylinder actuating means positioned outside the mandrel and between the packer seal and the slip means for setting the slip means and the packer seal,
 - said well packer being longitudinally flexible for allowing bending about the longitudinal axis of the well packer for allowing the packer to be spooled on a coiled tubing reel.
2. The well packer of claim 1 wherein the piston and cylinder actuating means is longitudinally flexible.
3. The well packer of claim 2 including,
 - a breakable protective coating initially positioned around the packer seal and the slip means.
4. A straight pull release well packer, configured for use with a spoolable flexible coiled tubing completion system having an outer diameter, comprising,
 - a tubular member having a bore therethrough and having an outer diameter substantially equal to the outer diameter of said coiled tubing,
 - a packer seal positioned about said tubular member,

13

*at least one slip connected to an outside surface of said tubular member;
said packer and said slip being retractable to an outer dimension substantially equal to the outside diameter of said coiled tubing,
a slip actuator positioned on the outside of said tubular member,*

14

*a packer seal actuator positioned on the outside of said tubular member.
5. A straight pull release well packer according to claim 4,
wherein said slip actuator and said packer seal actuator are integrated.*

* * * * *