

⑫

**EUROPEAN PATENT SPECIFICATION**

④⑤ Date of publication of patent specification: **21.12.88**

⑤① Int. Cl.<sup>4</sup>: **D 03 C 3/24**

②① Application number: **85101546.1**

②② Date of filing: **13.02.85**

---

⑤④ **Two-armed lifting hook with differentiated structure and jacquard weave machine produced therewith.**

---

③⑩ Priority: **29.02.84 IT 1984884**

④③ Date of publication of application:  
**18.09.85 Bulletin 85/38**

④⑤ Publication of the grant of the patent:  
**21.12.88 Bulletin 88/51**

⑧④ Designated Contracting States:  
**AT BE CH DE FR GB LI LU NL SE**

⑤⑩ References cited:  
**DE-B-1 292 090**  
**FR-A-1 350 392**  
**FR-A-2 498 640**

⑦③ Proprietor: **FIMTESSILE FABBRICA ITALIANA**  
**MACCHINARIO TESSILE S.p.A.**  
**Via Spiazzi, 52**  
**I-24028 Ponte Nossa (Bergamo) (IT)**

⑦② Inventor: **Epis, Olivo**  
**Via Monsignor Davide Re, 19**  
**Ponte Nossa (Bergamo) (IT)**

⑦④ Representative: **Vatti, Paolo, Dr. Ing. et al**  
**Fumero - Studio Consulenza Brevetti**  
**Widenmayerstrasse 4/1**  
**D-8000 München 22 (DE)**

**EP 0 154 823 B1**

---

Note: Within nine months from the publication of the mention of the grant of the European patent, any person may give notice to the European Patent Office of opposition to the European patent granted. Notice of opposition shall be filed in a written reasoned statement. It shall not be deemed to have been filed until the opposition fee has been paid. (Art. 99(1) European patent convention).

---

## Description

The present invention relates to Jacquard weave machines.

Several versions of these machines are already known in technique and, though generally working in a satisfactory way, they all have the fault not to allow working at the high speeds now demanded by modern looms. The impossibility for such machines to work at high speeds derives from the fact that the lifting hooks are highly subject to deformation, on account of their traditional structure. The present invention therefore proposes to solve the aforementioned problem by supplying, first of all, a two-armed lifting hook having a rationally differentiated structure, allowing to guarantee — on one hand — the stiffness required for an efficient working, with no harmful vibrations and at higher speeds than those usually adopted for weave machines, and providing — on the other hand — the resiliency which characterizes two-armed lifting hooks and which is indispensable for their characteristic way of operating. The invention also relates to other improvements in the weave machine, which allow to profit by the advantages deriving from the improved structure of the lifting hooks.

The improved two-armed lifting hook according to the invention is of the type having an upper resilient portion formed of two filiform metal arms with top beaks and a lower flat stiff portion, already known, for example from FR-A-1350392, and is characterised in that said lower flat stiff portion of the lifting hook consists of a shaped plate, connecting said arms and rigidly connected to each arm along a substantial length thereof so as to form one piece therewith.

Preferably one of said arms has an extension carrying in its lower part a hook for gripping the lifting hook return means.

Preferably, also, in the lifting hook according to the invention, the tooth for engaging the fixed blade and the shaped seat for bearing onto the fixed bottom blade are obtained in one piece with said plate, which extends in height from the area of said tooth downward.

A Jacquard weave machine according to a preferred embodiment of the invention is in turn characterized by the fact that, in addition to being equipped with two-armed lifting hooks of the type heretofore specified, it comprises for each lifting hook a transversal locking bar, positioned below the level of the fixed blade, substantially at the level of the fixed bottom blade, on the side of the lifting hook opposite to that on which said blades are positioned.

The invention will now be described in further detail, with reference to a presently preferred embodiment thereof, illustrated by the accompanying drawings, in which:

Fig. 1 is the diagram of a Jacquard weave machine according to the invention, of which the essential members are shown;

Fig. 2 shows, on an enlarged scale, a partially

interrupted view of a lifting hook according to the invention; and

Figs. 3 and 4 are views similar to that of figure 2, but with the lifting hook in two different operating conditions in respect of some parts of the Jacquard machine, which are also shown.

Figure 1 diagrammatically represents, as said, the essential members of a Jacquard weave machine according to the present invention.

In known manner, the lifting hooks motion programme, reported on a punched tape 1, is read by the needles 2, which either lift or keep lowered the pushers 3. The pushers 3 being lifted, are pressed by blades 4 and impart an axial movement on the main needles 5, against the action of springs 6. The main needles 5 are provided with teeth 7, which surround the lifting hooks 8 to control the transversal movements thereof.

The lifting hooks 8 bear onto fixed bottom blades 9, when having to stay at rest, and on fixed blades 10, when having to stop in the high end-of-stroke position. Lower moving blades 11 and upper moving blades 12, provided with reciprocating and opposed vertical motion, are apt to cooperate with the upper beaks 13 of the lifting hooks 8, while — according to the invention — transversal bars 14 are apt to stop the lifting hooks 8 and stabilize the beaks 13 thereof during the lifting and lowering movements. The lifting hooks 8 are held crosswise by guides 15 and 16, positioned above and beneath the push needles 5.

As known, during operation of these machines, when a lifting hook has to be moved — for instance lifted — in the presence of a perforation on the tape 1, by the moving blade 11 which practically finds itself in its low end-of-stroke position, as indicated in figure 1 — the lifting hook 8 is not shifted by the main needle 5, whereby its beak 13 is caught by the blade 11 and carried in a high position. Viceversa, in the absence of a perforation on the tape 1, a lifting hook 8 which finds itself in a high position (namely engaged by the blade 10), after having been caught and lifted by a moving blade 12, is pressed to disengage the beak 13 from the blade 10 and is kept pressed up to when, in the down-stroke, said beak 13 reaches a level below that of the blade 10, to subsequently regain the original position and move down to bear onto the bottom blade 9, corresponding to the lowest position.

As known, said lifting and lowering movement of the lifting hooks corresponds to the lifting and lowering movement of the yarns to produce the weaving shed. As also known, each lifting hook can lift one or more stitches, and each stitch is under the action of return means.

According to the invention, the lifting hooks 8 are made with a differentiated structure, having a resilient upper portion and a stiff lower portion.

Figure 2 represents, in a diagrammatic form and on an enlarged scale, a preferred (but not restrictive) embodiment of the lifting hook according to the invention. As shown, the lifting

hook 8 is formed of an upper very resilient portion, consisting of two wire arms 17 and 18 ending with top beaks 13, and of a lower very stiff and compact portion, consisting of a shaped metal plate 19, on the sides of which are welded the two arms 17 and 18 and the lower extension 20 of the arm 18 terminating with the hook 21 for gripping the lifting hook return means. The shaped plate 19 of the lifting hook embodiment shown in figure 2 comprises, in one piece therewith, the tooth 22 for engaging the fixed blade 10 and the shaped seat 23 for bearing onto the fixed bottom blade 9. The plate 19 extends in height, from slightly above the level of the tooth 22 downward.

The lifting hook thus obtained, while being sufficiently elastic in its upper part in order to guarantee a proper working of the Jacquard machine, to the requirements of which it hence adapts itself in a conventional manner, does not undergo in its lower part thanks to its very stiff and compact structure any significant deformation, deriving from the movements performed thereby and the stresses imparted thereon (of course, as long as operating with normal loads and overloads).

This particular stiffness allows the lifting hook to work in a precise manner and without vibrations, even at high and very high speeds of the weave machine, guaranteeing a perfect engagement of the beaks 13 by the blades 11 and 12, while a contrasting pulling force acts on the hook 21, due to the return means.

On the other hand, the structure of the lifting hook 8 is such that, when this latter finds itself in the open-shed condition (top dead point), the return force imparted thereon by the appropriate means forces said lifting hook against the blades 10 and the bottom blades 9, eliminating any possibility of vibration.

Moreover, the shape of the lifting hook 8 in its section between the shaped seat 23, where it bears onto the fixed blade 9, and the hook 21 allows to guide said lifting hook in its lifting and lowering movement, permitting to considerably reduce the total height of the Jacquard machine, in order to make it more stable and notably increase its working speed.

The Jacquard weave machine according to the invention is not only characterized by the presence therein of lifting hooks as those heretofore described, but also by being provided with the already described transversal locking bars 14, the function of said bars — as can be seen at once — being important in order to stabilize even further the behaviour of the lifting hooks in the operation of the Jacquard machine.

Figure 3 shows an anomalous position of the lifting hook 8 according to the invention, while it is moving downward and away — for instance due to anomalous vibrations — from the fixed bottom blade 9. In this position, the advantage provided by the bar 14 for stability purposes is quite evident, said bar preventing the lifting hook from moving even further away from the blade 9,

and actually forcing said hook to return in its correct position (which it will finally take up also due to the mutual cooperation between the inclined surfaces 9A and 23A of the fixed bottom blade 9 and of the shaped seat 23).

Whereas, in figure 4, the lifting hook 8 is shown while being forced to stay in a lifted position — due to engagement of the blade 12 with the beak 13 — while, not having been shifted by the needle 5, it has to engage with the fixed blade 10; in this phase, always on account of anomalous vibrations, the lifting hook 8 could move sideways up to disengaging from the blade 10, if this were not again prevented by the presence of the bar 14 which forces said lifting hook into the correct position, as clearly shown in the drawing.

It should be noted that the slack existing between the lifting hook 8 and the bar 14 allows to limit the deformation of the resilient portion of said lifting hook, when it has to disengage from the blade 10, since part of the deformation is eliminated by the actual movement of the lifting hook. Less deformation of the lifting hook means less stress applied between the arms of said hook and the teeth 7 of the needle 5, with consequent less possibility of wear of such teeth. This represents a further important advantage of the machine according to the invention.

It is understood that there may be other embodiments of the improved lifting hook according to the invention, differing from that heretofore described and illustrated and falling within the scope of the present invention. In particular, the stiffening of the lower part of the lifting hook may be obtained by connecting the shaped plate to the filiform arms otherwise than by welding, or by producing the tooth 22 and the shaped seat 23 as separate pieces, connected one to the other and to the remaining structure of the lifting hook by stiffening brackets.

#### Claims

1. Two-armed lifting hook for Jacquard weave machines, of the type having an upper resilient portion formed of two filiform metal arms with top beaks, and a lower flat stiff portion, characterized in that said lower flat stiff portion consists of a shaped plate connecting said arms and rigidly connected to each arm along a substantial length thereof, so as to form one piece therewith.

2. Two-armed lifting hook as in claim 1), wherein one of said arms has an extension which carries in its lower part the hook for gripping the lifting hook return means.

3. Two-armed lifting hook as in claim 2, wherein the tooth for engaging the fixed blade and the shaped seat for bearing onto the fixed bottom blade, are obtained in one piece with said shaped plate.

4. Two armed lifting hook as in claim 1), wherein the tooth for engaging the fixed blade and the shaped seat for bearing onto the fixed bottom blade, are separate and distinct elements being fixedly connected one to the other and to

the remaining structure of the lifting hook by means of stiffening brackets.

5. Two-armed lifting hook as in claims 1 to 3, wherein said shaped plate is a metal plate connected by welding to said arms and to the extension of one of said arms.

#### Patentansprüche

1. Zweiarmiger Hubhaken für Jacquard-Webmaschinen von der Art mit einem oberen nachgiebigen Abschnitt, der aus zwei Metallarmen mit oberen Nasen gebildet ist und einen unteren, flachen, steifen Abschnitt, dadurch gekennzeichnet, daß der untere, flache, steife Abschnitt aus einer geformten Platte besteht, die die Arme verbindet und mit jedem Arm fest verbunden ist über eine erhebliche Erstreckung von diesem, so daß es mit diesen einstückig ist.

2. Zweiarmiger Hubhaken nach Anspruch 1, wobei der eine der Arme eine Erstreckung hat, die an ihrem unteren Teil den Haken zum Ergreifen der Rückstellmittel für den Hubhaken trägt.

3. Zweiarmiger Hubhaken nach Anspruch 2, wobei der Zahn zum Ergreifen des festen Blattes und der geformte Sitz zum Aufliegen auf dem festen unteren Blatt einstückig mit der geformten Platte ausgebildet sind.

4. Zweiarmiger Hubhaken nach Anspruch 1, wobei der Zahn zum Ergreifen des festen Blattes und der geformte Sitz zum Aufliegen auf dem unteren festen Blatt getrennte und gesonderte Elemente sind, die fest miteinander und mit dem restlichen Aufbau des Hubhakens mittels Versteifungsträgern verbunden sind.

5. Zweiarmiger Hubhaken nach den Ansprüchen 1 bis 3, wobei die geformte Platte eine Metallplatte ist, die durch Verschweißen mit den

Armen und mit Erstreckung eines der Arme verbunden ist.

#### Revendications

1. Crochet élévateur à deux bras pour métiers à tisser Jacquard, du type possédant une partie élastique supérieure constituée de deux bras métalliques filiformes avec des becs supérieurs, et une partie rigide plate inférieure, caractérisé en ce que ladite partie rigide plate inférieure consiste en une plaque façonnée reliant lesdits bras et reliée de façon rigide à chaque bras sur une longueur importante de ceux-ci de façon à constituer une seule pièce avec eux.

2. Crochet élévateur à deux bras selon la revendication 1, dans lequel un desdits bras possède un prolongement qui porte à sa partie inférieure le crochet en vue de saisir les moyens de rappel de crochet élévateur.

3. Crochet élévateur à deux bras selon la revendication 2, dans lequel la dent destinée à venir en contact de la lame fixe et le siège façonné en vue de s'appuyer sur la lame inférieure fixe, sont obtenus d'une seule pièce avec ladite plaque façonnée.

4. Crochet élévateur à deux bras selon la revendication 1, dans lequel la dent destinée à venir en contact de la lame fixe et le siège façonné en vue de s'appuyer sur la lame inférieure fixe, sont des éléments séparés et distincts reliés à demeure l'un à l'autre et au reste de la structure du crochet élévateur au moyen des supports de renfort.

5. Crochet élévateur à deux bras selon les revendications 1 à 3, dans lequel ladite plaque façonnée est une plaque de métal reliée par soudure auxdits bras et au prolongement d'un desdits bras.

5

10

15

20

25

30

35

40

45

50

55

60

65

4

FIG.1

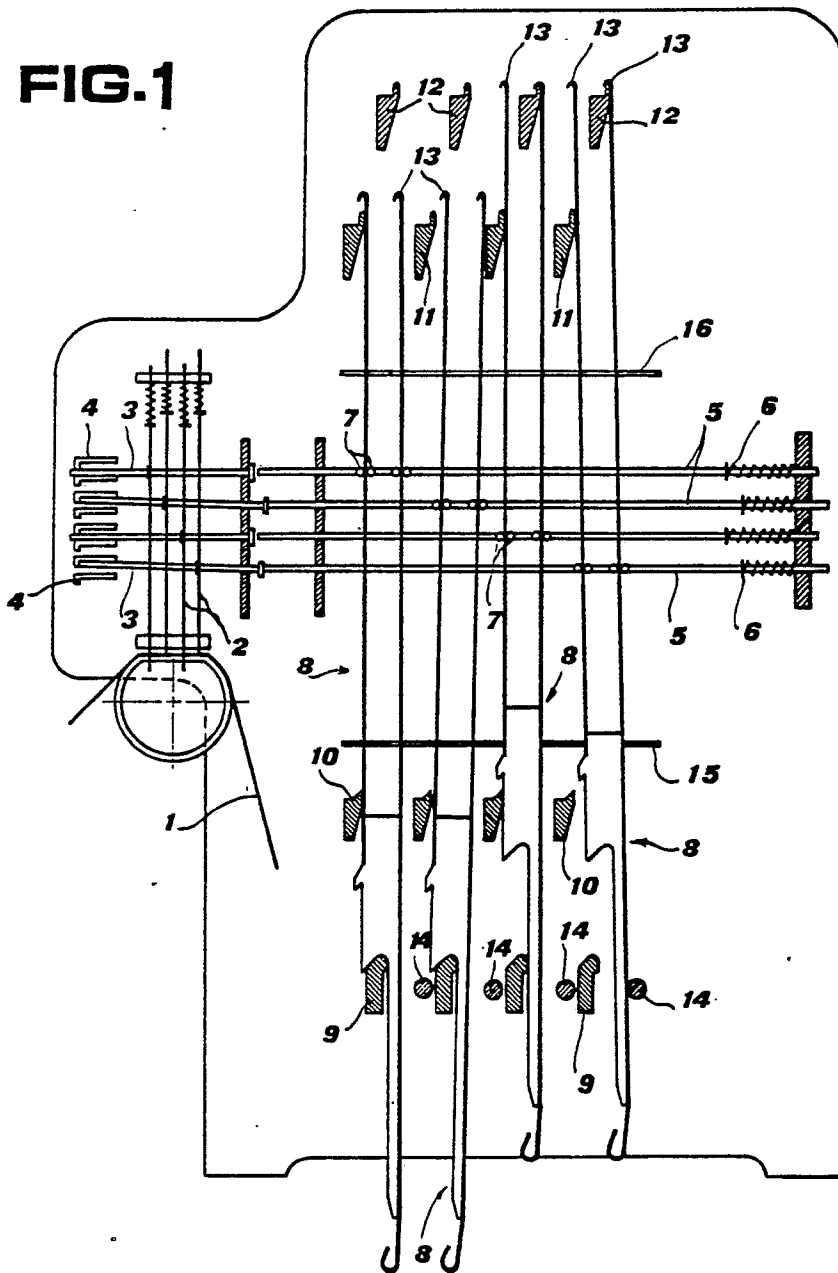
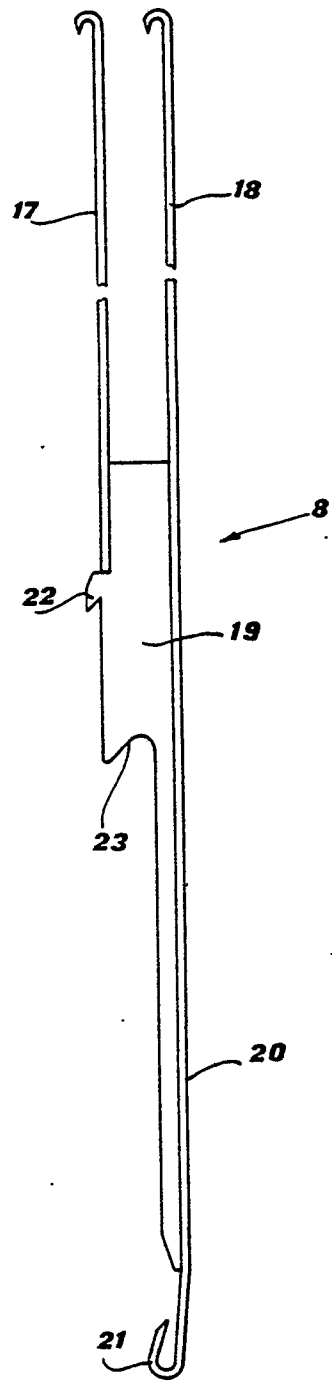

FIG.2



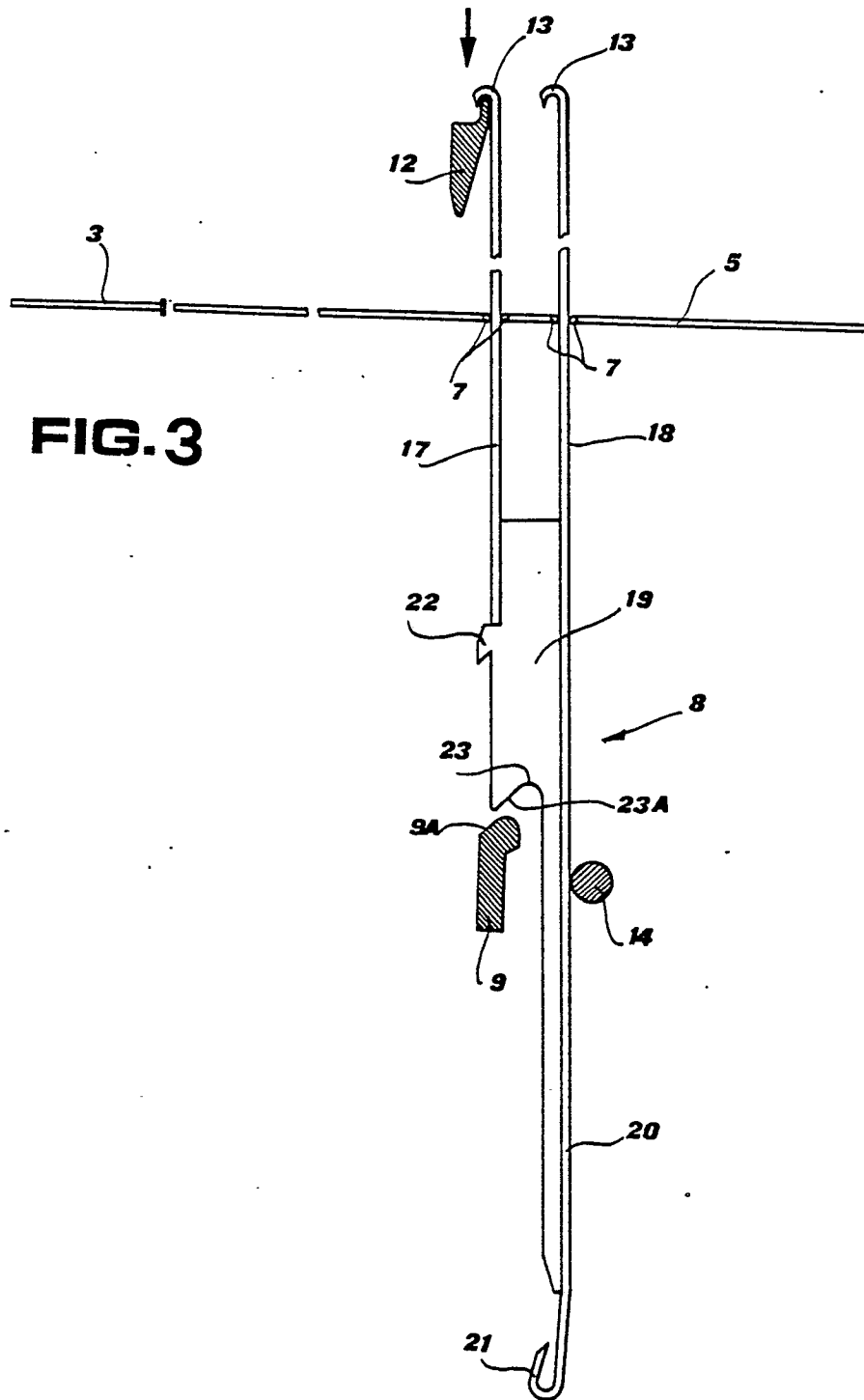

FIG.3

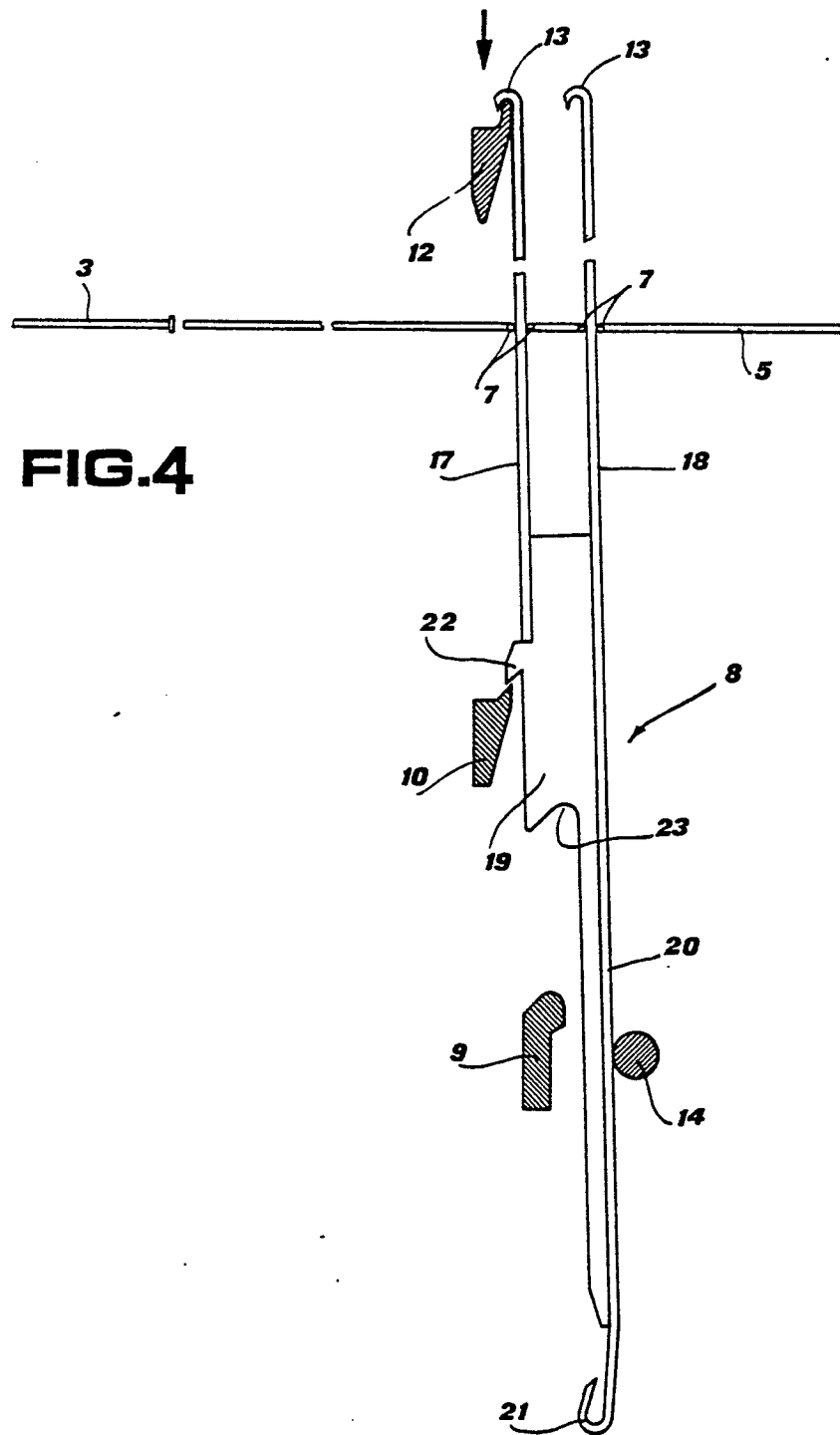

FIG. 4