



INTERNATIONAL APPLICATION PUBLISHED UNDER THE PATENT COOPERATION TREATY (PCT)

<p>(51) International Patent Classification ⁶ : H04B 1/44, 1/38, H01Q 1/24</p>	<p>A1</p>	<p>(11) International Publication Number: WO 98/52293 (43) International Publication Date: 19 November 1998 (19.11.98)</p>
<p>(21) International Application Number: PCT/US98/09645 (22) International Filing Date: 11 May 1998 (11.05.98) (30) Priority Data: 08/856,244 14 May 1997 (14.05.97) US (71) Applicant: SONY ELECTRONICS, INC. [US/US]; 1 Sony Drive, Park Ridge, NJ 07656-8003 (US). (72) Inventors: TSUDA, Shinichiro; 5205 Fiore Terrace, San Diego, CA 92122-5643 (US). TORIYAMA, Ichiro; 13156 Scabard Place, San Diego, CA 92128-4054 (US). SATO, Naotaka; 12670 Torrey Bluff Drive #271, San Diego, CA 92130-4262 (US). (74) Agent: FROMMER, William, S.; Frommer Lawrence & Haug LLP, 745 Fifth Avenue, New York, NY 10151 (US).</p>		<p>(81) Designated States: AL, AM, AT, AU, AZ, BA, BB, BG, BR, BY, CA, CH, CN, CU, CZ, DE, DK, EE, ES, FI, GB, GE, GH, GM, GW, HU, ID, IL, IS, JP, KE, KG, KP, KR, KZ, LC, LK, LR, LS, LT, LU, LV, MD, MG, MK, MN, MW, MX, NO, NZ, PL, PT, RO, RU, SD, SE, SG, SI, SK, SL, TJ, TM, TR, TT, UA, UG, UZ, VN, YU, ZW, ARIPO patent (GH, GM, KE, LS, MW, SD, SZ, UG, ZW), Eurasian patent (AM, AZ, BY, KG, KZ, MD, RU, TJ, TM), European patent (AT, BE, CH, CY, DE, DK, ES, FI, FR, GB, GR, IE, IT, LU, MC, NL, PT, SE), OAPI patent (BF, BJ, CF, CG, CI, CM, GA, GN, ML, MR, NE, SN, TD, TG).</p> <p>Published <i>With international search report. Before the expiration of the time limit for amending the claims and to be republished in the event of the receipt of amendments.</i></p>

(54) Title: ANTENNA ARRANGEMENT FOR PORTABLE TWO-WAY RADIO APPARATUS

(57) Abstract

A portable radio apparatus for transmitting and receiving radio waves in respective transmitting and receiving band widths, as in a cellular phone, has a portable housing containing circuits defining a transmitting path (102) and a receiving path (103) which are substantially spaced from each other within the housing (101) and which exit from the latter at respective substantially spaced apart locations where the transmitting (104) and receiving (105) antennas are mounted on the housing and there connected with the transmitting and receiving paths, respectively, with such transmitting and receiving antennas being configured for transmitting and receiving radio waves substantially only in the transmitting and receiving band widths, respectively. The housing comprises a main body portion and a swingable portion. The main body portion includes a loudspeaker. The transmitting antenna extends from the top end of the main body portion. The swingable portion extends from the opposing end of the main body portion and includes a microphone and the receiving antenna.

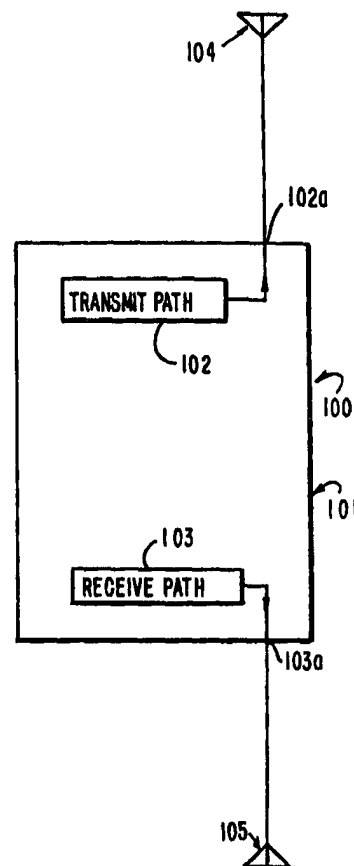

FOR THE PURPOSES OF INFORMATION ONLY

Codes used to identify States party to the PCT on the front pages of pamphlets publishing international applications under the PCT.

AL	Albania	ES	Spain	LS	Lesotho	SI	Slovenia
AM	Armenia	FI	Finland	LT	Lithuania	SK	Slovakia
AT	Austria	FR	France	LU	Luxembourg	SN	Senegal
AU	Australia	GA	Gabon	LV	Latvia	SZ	Swaziland
AZ	Azerbaijan	GB	United Kingdom	MC	Monaco	TD	Chad
BA	Bosnia and Herzegovina	GE	Georgia	MD	Republic of Moldova	TG	Togo
BB	Barbados	GH	Ghana	MG	Madagascar	TJ	Tajikistan
BE	Belgium	GN	Guinea	MK	The former Yugoslav Republic of Macedonia	TM	Turkmenistan
BF	Burkina Faso	GR	Greece	ML	Mali	TR	Turkey
BG	Bulgaria	HU	Hungary	MN	Mongolia	TT	Trinidad and Tobago
BJ	Benin	IE	Ireland	MR	Mauritania	UA	Ukraine
BR	Brazil	IL	Israel	MW	Malawi	UG	Uganda
BY	Belarus	IS	Iceland	MX	Mexico	US	United States of America
CA	Canada	IT	Italy	NE	Niger	UZ	Uzbekistan
CF	Central African Republic	JP	Japan	NL	Netherlands	VN	Viet Nam
CG	Congo	KE	Kenya	NO	Norway	YU	Yugoslavia
CH	Switzerland	KG	Kyrgyzstan	NZ	New Zealand	ZW	Zimbabwe
CI	Côte d'Ivoire	KP	Democratic People's Republic of Korea	PL	Poland		
CM	Cameroon	KR	Republic of Korea	PT	Portugal		
CN	China	KZ	Kazakstan	RO	Romania		
CU	Cuba	LC	Saint Lucia	RU	Russian Federation		
CZ	Czech Republic	LI	Liechtenstein	SD	Sudan		
DE	Germany	LK	Sri Lanka	SE	Sweden		
DK	Denmark	LR	Liberia	SG	Singapore		
EE	Estonia						

ANTENNA ARRANGEMENT FOR PORTABLE TWO-WAY RADIO APPARATUS
BACKGROUND OF THE INVENTION

Field of the Invention

This invention relates generally to portable
5 two-way radio apparatus, such as, cellular phones and the
like, and more particularly is directed to an improved
antenna arrangement by which such apparatus may transmit
and receive radio waves.

Description of the Prior Art

10 As two-way radio and cellular phones have
achieved wide-spread use, much effort has been expended
in reducing the weight and size thereof for enhancing the
ease and convenience with which such devices may be
carried. An area thereof that has seen considerable
15 development has been the arrangement provided for
achieving duplex operation, that is, permitting the user
to speak and listen at the same time. Such duplex
operation requires two radio channels, that is, a
transmitting band and a receiving band in which the
20 cellular phone may simultaneously transmit and receive,
respectively. In the belief that simplification would be
achieved thereby, existing cellular phones, for example,
as indicated in block form at 10 on Fig. 1, have been
provided with a single antenna 11 extending from the
25 housing 12 and being designed with a broad band
characteristic so as to cover the total band width of the
respective cellular phone system, such as, the Advanced
Mobile Phone System (AMPS) in the U.S.A., the Total
Access Communications System (TACS) in the U.K., the
30 Nordic Mobile Telephone System (NMT) in Scandinavia, the
Global System for Mobile Communications (GSM) specified
by the Committee of European Post and Telecommunications,
and the like. Such broad band characteristic of the
single antenna for both transmission and reception has to
35 be more than twice as wide as the band width of the
transmitting band or the receiving band. Many
difficulties have been encountered in achieving the

desired broad band performance in a single antenna structure that can be accommodated in the limited space available therefor within the miniaturized cellular phones being produced in accordance with the latest
5 trend.

Furthermore, as shown in Fig. 1, a cellular phone 10 having the single antenna 11 for both transmitting and receiving must further include a duplexer 13 by which the total band width of the
10 respective system is divided between the transmitting band and the receiving band. In any event, a transmitting path 14 and a receiving path 15 defined on a circuit board within the housing 12 must necessarily have at least portions that are physically close to each other
15 in consideration of the desired miniaturization of the housing 12, and further by reason of the fact that such transmitting path 14 and receiving path 15 extend to the same antenna 11. Such close proximity of the receiving and transmitting paths gives rise to a tendency for
20 transmitting power to leak from the transmitting path to the receiving path. Leakage from the transmitting path to the receiving path is known to cause cross-modulation and the like and, in order to avoid such problem, the duplexer 13 is required to have a high isolation
25 characteristic which can suppress the leakage. However, a duplexer capable of the desired high isolation performance is of increased size and thereby conflicts with the present trend to miniaturize cellular phones.

OBJECTS AND FEATURES OF THE INVENTION

30 Accordingly, it is an object of this invention to provide a portable radio apparatus for transmitting and receiving radio waves in respective band widths, for example, as in a cellular phone, and in which leakage between transmitting and receiving paths is avoided
35 without the necessity of employing a duplexer, while permitting optimum reduction of the weight and size of the apparatus.

A further object is to provide an apparatus, as aforesaid, for use in a digital cellular phone system, and in which the occurrence of puncturing audio noise is avoided by optimizing the distance between the
5 transmitting antenna and the microphone.

Still another object of the invention is to provide an apparatus, as aforesaid, which can be manipulated to a folded or stowed position when not in use so as to be conveniently carried in a pocket or other
10 confined space.

In accordance with an aspect of this invention, a portable radio apparatus for transmitting and receiving radio waves in respective transmitting and receiving band widths, for example, as in a cellular phone, has a
15 portable housing containing circuit means, such as, a circuit board, for processing transmitted and received radio waves, respectively, and defining a transmitting path and a receiving path which are substantially spaced from each other within the housing and which exit from
20 the latter at respective substantially spaced apart locations, and transmitting and receiving antennas mounted on the housing and being there connected with the transmitting and receiving paths, respectively, at the substantially spaced apart locations where such paths
25 exit from the housing, with such transmitting and receiving antennas being configured for transmitting and receiving radio waves substantially only in the transmitting and receiving band widths, respectively.

In accordance with another aspect of this
30 invention, the housing of a portable radio apparatus, as aforesaid, includes a main body portion containing a loudspeaker and a swingable portion containing a microphone and being pivoted in respect to the main body portion for movement between a stowed position where the
35 swingable portion lies substantially flat against the main body portion and an operative position where the swingable portion extends from the main body portion for

disposing the microphone at a desired distance from the loudspeaker, and one of the antennas extends from the main body portion of the housing while the other antenna is included in the swingable portion of the housing so as
5 to lie against the main body portion in the stowed position of the swingable portion and for maximum spacing of the antennas from each other when the swingable portion is in its operative position.

In accordance with still another aspect of this
10 invention, a portable radio apparatus, as aforesaid, for use in a digital cellular phone system has its transmitting antenna extending from the main body portion and its receiving antenna included in the swingable portion of the housing containing the microphone which is
15 thereby substantially distanced from the transmitting antenna for discouraging signal leakage from the transmitting antenna to the microphone and consequent puncturing audio noise.

It is still another feature of the invention to
20 provide a portable radio apparatus, as aforesaid, in which the main body portion and the swingable portion of the housing are of a molded plastic material, and in which the antenna included in the swingable portion of the housing includes a monopole rod antenna element of
25 metal embedded in the plastic material of such swingable portion for also strengthening the latter.

The above, and other objects, features and advantages of the invention, will be apparent in the following detailed description of illustrative
30 embodiments, particularly when read in connection with the accompanying drawings.

BRIEF DESCRIPTION OF DRAWINGS

Fig. 1 is a block diagram of an antenna system of a portable two-way radio apparatus according to the
35 prior art;

Fig. 2 is a block diagram illustrating a characteristic feature of an antenna system of a portable

two-way radio apparatus according to the present invention;

Fig. 3A is a schematic view of a portable two-way radio apparatus, such as, a cellular telephone, 5 having an antenna arrangement according to an embodiment of the present invention, and which is shown with a receiving antenna thereof in a stowed position;

Fig. 3B is a view similar to that of Fig. 3A, but with the receiving antenna shown in an operative or 10 extended position; Figs. 4A and 4B are views similar to those of Figs. 3A and 3B, respectively, but illustrating another embodiment of the present invention characterized by a different form of transmitting antenna;

15 Figs. 5A and 5B are views similar to Figs. 4A and 4B, respectively, but illustrating another embodiment of this invention characterized by still another form of transmitting antenna;

20 Figs. 6A and 6B are views similar to those of Figs. 3A and 3B, respectively, but showing still another embodiment of this invention characterized by a different form of receiving antenna;

Figs. 7A and 7B are views similar to those of Figs. 6A and 6B, respectively, but illustrating yet 25 another embodiment of this invention characterized by a different form of transmitting antenna;

Figs. 8A and 8B are also views similar to those of Figs. 6A and 6B, respectively, but illustrating a still further embodiment of this invention characterized 30 by still another form of transmitting antenna;

Figs. 9A and 9B are graphical representations of the impedance characteristics of the transmitting antenna of the embodiment of Figs. 4A and 4B when the receiving antenna is in the positions of Figs. 4A and 4B, 35 respectively; and

Figs. 10A and 10B are graphical representations of the impedance characteristics of the receiving antenna

of the embodiment of Figs. 4A and 4B when such receiving antenna is in the positions shown on Figs. 4A and 4B, respectively.

DETAILED DESCRIPTION OF PREFERRED EMBODIMENTS

5 Referring now to Fig. 2 of the drawings, it will be seen that, in accordance with an essential feature of the present invention, a portable radio apparatus 100, for example, a cellular phone, for transmitting and receiving radio waves in respective
10 transmitting and receiving band widths comprises a portable housing 101 containing circuits for processing transmitted and received radio waves, respectively, and which include a transmitting path 102 and a receiving path 103 substantially spaced from each other within the
15 housing 101. Such transmitting and receiving paths 102 and 103 are shown to exit from the housing 101 at respective substantially spaced apart locations 102a and 103a. Further, the apparatus 100 according to this invention is shown to generally comprise a transmitting
20 antenna 104 and a separate receiving antenna 105 which are mounted on the housing 101 at the spaced apart locations 102a and 103a, respectively, where the transmitting and receiving antennas 104 and 105 are connected with the transmitting and receiving paths 102
25 and 103, respectively. Moreover, in accordance with the present invention, the transmitting and receiving antennas 104 and 105 are configured for transmitting and receiving radio waves substantially only in the respective transmitting and receiving band widths of the
30 cellular phone system or the like in which the portable radio apparatus 100 is designed to be used.

Since the transmitting and receiving antennas 104 and 105 are intended for use only in connection with radio waves within the relatively narrow band widths
35 prescribed by the respective system for the transmitting and receiving channels, respectively, such antennas can be readily designed to perform the assigned functions

without presenting obstacles to the desired miniaturization of the cellular phone or other portable radio apparatus. Further, since separate antennas 104 and 105 are used for transmission and reception, 5 respectively, such antennas may be relatively widely spaced from each other on the housing 101 and the transmitting path 102 and the receiving path 103, being connected to respective antennas 104 and 105 spaced apart on the housing 101, can be also substantially spaced from 10 each other, for example, on the printed circuit board which carries the various circuits within the housing 101. Thus, as shown on Fig. 2, there is no need to provide a duplexer in the apparatus 100 in order to make it possible for the user to speak and listen at the same 15 time. The apparatus 100 of Fig. 2 further advantageously enjoys a possible reduction in weight and size by reason of the absence therefrom of the duplexer 13 in the prior art apparatus 10 of Fig. 1.

By maintaining a substantial physical distance 20 between the antennas 104 and 105 and also between the transmitting path 102 and receiving path 103 within the housing 101, there is desirably small leakage, if any, of the transmitting power from the transmitting path 102 to the receiving path 103.

25 Referring now to Figs. 3A and 3B, it will be seen that the cellular phone 100a in accordance with an embodiment of this invention, as there shown in greater detail, comprises a housing 101a which includes a main body portion 106 containing a loudspeaker 108, and a 30 swingable portion 107 containing a microphone 109 and being pivoted in respect to the main body portion 106 for movement between a stowed position (Fig. 3A) where the swingable portion 107 lies substantially flat against the main body portion 106, and an operative position (Fig. 35 3B) where the swingable portion 107 of the housing extends from the main body portion for disposing the microphone 109 at a desired distance d from the

loudspeaker 108. The distance d is selected so that, with the swingable housing portion 107 in its operative position, the user's ear and mouth may be disposed adjacent the loudspeaker 108 and the microphone 109, respectively. Further, in the cellular phone 100a shown in Figs. 3A and 3B, the transmitting antenna, shown in the form of a rod antenna element 104a, extends upwardly from the upper end of the main body portion 106 of the housing, while the other or receiving antenna, also shown in a form of a rod antenna element 105a, is included in the swingable portion 107 of the housing which is pivoted for movement relevant to the main body portion 106 about an axis x-x which is located adjacent the lower end of the main body portion 106. Thus, when the swingable portion 107 of the housing 101a is in its downwardly directed operative position (Fig. 3B), there is a maximum spacing of the antennas 104a and 105a from each other. Of course, when the swingable portion 107 of the housing 101a is disposed in its stowed position flat against the main body portion 106 (Fig. 3A), the overall dimensions of the cellular phone 100a are no greater than they would have been in the absence of the antenna 105a so as to facilitate the stowage thereof in a pocket or the like.

Further, in the cellular phone 100a of Figs. 3A and 3B, the microphone 109 is positioned in the swingable housing portion 107 beyond the end of the rod antenna element constituting the receiving antenna 105a which is remote from the axis x-x about which the swingable housing portion 107 is pivoted. By reason of the foregoing, when the cellular phone 100a is used in a digital cellular phone system, there is an optimum spacing of the microphone 109 from the transmitting antenna 104a when the swingable portion 107 of the housing is in the operative position (Fig. 3B) for avoiding the puncturing audio noise that may occur in a cellular phone system if the transmitting antenna and the microphone are too close to each other.

As is usually the case, the main body portion 106 and the swingable portion 107 of the housing 101a are desirably molded of a suitable plastic material, and the elongated metal rod included in the receiving antenna 5 105a is desirably embedded in the plastic material of the swingable housing portion 107, as shown, for strengthening such swingable portion. Since cellular phones having swingable housing portions containing a microphone for movement between stowed and operative or 10 extended positions are frequently provided with metal stiffening members, the rod antenna element 105a in acting as a stiffening element and also as the receiving antenna performs that additional function without increasing the weight of the cellular phone.

15 In the cellular phone 100a of Figs. 3A and 3B, a printed circuit board 110 is contained within the main body portion 106 of the housing 101 and has thereon circuits for processing the transmitted and received signals, including printed circuits defining the 20 transmitting path 102 and the receiving path 103 which, for the reasons earlier stated, are substantially spaced from each other on the printed circuit board 110. The rod antenna element 104a which constitutes the transmission antenna is secured, at its lower end, on a 25 metal base 111 which is externally threaded and screwed into an internally threaded metal socket or mounting member 112 embedded in the plastic main body portion 106 adjacent to the location 102a. An RF circuit 113 extends from the transmitting path 102 on the circuit board 110 30 and is connected to the socket 112 by means of an antenna clip 114 for supplying the signal to be transmitted through the socket 112 and base 111 to the monopole antenna 104a. The monopole or rod antenna element 104a is enclosed in a cover 115 to prevent contact of the user 35 with the antenna itself.

In the case of the rod antenna element 105a constituting the receiving antenna of the cellular phone

100a, the end portion of the rod antenna element 105a remote from the microphone 109 is desirably bent at right angles and terminates in a cylindrical hub portion 116 which is rotatably received in a metal socket 117
5 embedded in the main body portion 106 of the housing 101a adjacent the location 103a. With such structural arrangement, the hub 116 at an end of the rod antenna element 105a, by its engagement in the socket 117, defines the axis x-x about which the swingable housing
10 portion 107 is pivoted relative to the main body portion 106. The receiving path 103 is connected through an RF circuit 118 and an antenna clip 119 with the metal socket 117 in which the hub-like end portion 116 of the rod antenna element 105a is turnable for establishing the
15 necessary electrical connection between the receiving antenna 105a and the respective circuits on the circuit board 110.

It will be appreciated that, when the cellular phone 100a is in its standby status, the swingable
20 housing portion 107 is flipped or pivoted to its retracted or stowed position shown in Fig. 3A for convenience in carrying the cellular phone in a pocket or the like. However, when the cellular phone 100a is to be used for talking, the swingable housing portion 107 is
25 flipped or pivoted to the position shown on Fig. 3B for obtaining the desired distance d between the loudspeaker 108 and microphone 109 and further for disposing the antenna 105a for improved reception as well as for avoiding cross-modulation and puncturing audio noise.

30 Referring now to Figs. 4A and 4B, it will be seen that a cellular phone 100b according to another embodiment of this invention is generally similar to the previously described cellular phone 100a. For the sake of brevity, the various parts of the cellular phone 100b
35 that are the same as corresponding parts of the above described cellular phone 100a are identified by the same reference numerals and will not be further described

herein. Thus, the cellular phone 100b substantially differs from the cellular phone 100a only in that the rod antenna element 104a constituting the transmission antenna in the latter is replaced by a helical antenna 104b having a conductive metal plate 120 at its lower end fixedly secured, in an electrically conducting manner, on the externally threaded base 111 screwed into the socket 112. The helical antenna 104b is enclosed within a suitable cover 115b to avoid user contact therewith. It will be appreciated that the cellular phone 100b is used in essentially the same manner as the previously described cellular phone 100a with similar advantages being derived from its antenna arrangement constituted by the rod antenna element 105a forming a monopole receiving antenna and the fixed helical transmitting antenna 104b. The fixed helical transmitting antenna 104b of the cellular phone 100b is further advantageous relative to the monopole or rod transmitting antenna 104a of the cellular phone 100a in that the helical antenna 104b has an effective electrical length greater than its physical length and therefore has better transmitting performance than a monopole or rod transmitting element of the same length. In the case of a fixed transmitting antenna, minimizing the physical length thereof without sacrificing its transmitting performance is a desirable end.

As an example of the antenna arrangement shown in Figs. 4A and 4B, the helical transmitting antenna 104b may have a pitch of 2.2 mm, a diameter of 5.3 mm, and 4.5 turns, while the monopole or rod antenna element constituting the receiving antenna 105a embedded in the swingable portion 107 of the housing which contains the microphone 109 has a length of 60 mm. With such dimensions of the transmitting and receiving antennas included in the cellular phone 100b embodying the invention, Figs. 9A and 9B graphically depict impedance characteristics of the transmission antenna 104b when the

swingable housing portion 107 containing the receiving antenna 105a is in its stowed position (Fig. 4A) and in its extended position (Fig. 4B), respectively.

Similarly, Figs. 10A and 10B graphically depict impedance characteristics of the receiving antenna 105a when the swingable housing portion 107, and hence the receiving antenna 105a, is in its stowed position (Fig. 4A) and in its extended position (Fig. 4B), respectively.

Referring now to Figs. 5A and 5B, it will be seen that a cellular phone 100c in accordance with still another embodiment of this invention is generally similar to the cellular phone 100a described above with reference to Figs. 3A and 3B, and, for the sake of brevity, those parts of the cellular phone 100c that are the same as corresponding parts in the cellular phone 100a are identified by the same reference numerals and will not be further described herein. However, the cellular phone 100c is characterized by a retractable transmitting antenna 104c which is shown to generally comprise a fixed helical antenna 121 housed within a cylindrical antenna cover 122, and a movable antenna part 123 constituted by a rod antenna element 124 enveloped in a cover 125.

The fixed helical antenna 121 further has a metal end piece 126 in the form of a disk secured to the lower end of the antenna 121 with an externally threaded hub 127 extending downwardly from the disk 126 about an axial bore 128. The lower end of the antenna cover 122 is suitably secured on the periphery of disk 126 for positioning the cover in enveloping relation to the helical antenna 121. The cover 122 has an upper end wall 129 above the upper end of the helical antenna 121 with a central bore 130 extending through end wall 129 in axial alignment with the bore 128 in hub 127. Such bores 128 and 130 are dimensioned so that the movable antenna part 123, that is, the rod antenna 124 and the associated cover 125, can move slidably through bores 128 and 130

between the extended and retracted positions of Figs. 5B and 5A, respectively.

A knob 131 is formed on, or otherwise secured to, the upper end of cover 125 and may be grasped by the user for effecting movements of the movable antenna part 123 between its extended and retracted positions. The knob 131 is also effective to prevent inadvertent downward separation of the movable antenna part 123 from the fixed helical antenna 121. An annular protrusion 132 is formed on antenna cover 125 immediately below knob 131 and is dimensioned for snap-in engagement in a similarly shaped indentation or detent formed in the bore 130 extending through end wall 129 of the cover 122. The engagement of the protrusion 132 in the detent or indentation in bore 130, as in Fig. 5A, is effective to releasably retain the movable antenna part 123 in its retracted position.

A stopper 133 is provided on the lower end portion of the cover 125 and is formed with an annular protrusion 134 which, upon movement of the movable antenna part 123 to the extended position shown in Fig. 5B, engages, in a snap-in manner, in a similarly shaped indentation or detent 135 formed in the surface of bore 128. Such engagement of protrusion 134 within indentation 135 is effective to releasably retain the movable antenna part 123 in its extended position. In the illustrated antenna assembly 100c, the stopper 133 at the lower end of the movable antenna part 123 is of an electrical insulating material, for example, of the same material as the cover 125, so that an electrical connection to the rod antenna 124 cannot be established through the stopper 133.

In order to provide for the mounting of the retractable antenna assembly 104c on the cellular phone 100c, the housing 101c of the latter is conventionally molded of a suitable plastic with an opening in which the conductive metal mounting socket 112 is embedded. Such

mounting socket 112 has an internally threaded bore in which the externally threaded hub 127 can be threadably engaged. When the antenna assembly 104c is thus mounted on housing 101c, the helical antenna 121 is continuously
5 powered from a power supply circuit through the antenna clip 114 which establishes an electrical connection between the RF signal line 113 extending from the transmitting path 102 and the metal mounting socket 112 which is, in turn, electrically connected with the hub
10 127 of the disk 126, and through the latter to the helical antenna 121.

When the movable antenna part 123 of antenna assembly 104c is in its extended position shown on Fig. 5B, rod antenna 124 extends through helical antenna 121.
15 By reason of the foregoing, even though, in the extended position, stopper 133 of an insulating material insures that there will be no electrical connection between helical antenna 121 and rod antenna 124, the rod antenna 124 is powered by electromagnetic coupling between
20 helical antenna 121 and rod antenna 124 extending axially therethrough. As a result, in the extended position, rod antenna 124 mainly operates as a monopole antenna which has its ground level at the ground of the shielding case conventionally provided within the housing 101c and the
25 ground of the circuit board 110 therein. Although the helical antenna 121, being continuously powered, is powered along with the rod antenna 124 when the latter is in its extended position, the helical antenna 121 is then merely operable as an accessory of the rod antenna 124.

30 On the other hand, when the movable antenna part 123 of assembly 104c is in its retracted position shown on Fig. 5A, there is no electrical connection to the rod antenna 124 and there is substantial axial spacing between the upper end of rod antenna 124 and the
35 lower end of the helical antenna 121 and the metal members 126, 127 and 112 connected thereto. As a result of the foregoing, electromagnetic coupling between the

helical antenna 121 and the rod antenna 124 is avoided when the movable antenna part 123 is in its retracted position. Therefore, rod antenna 124, when in its retracted position, has no affect on the performance of helical antenna 121 which then operates as a single helical antenna having its ground level at the ground of the shielding case inside housing 101c and the ground of the circuit board 110.

In a modification of the retractable antenna assembly 104c which includes a rod antenna 124 and a helical antenna 121, and in which the rod antenna 124, when retracted into the housing, is electrically isolated from the helical antenna 121, the stopper 133 of insulating material at the lower end of the movable antenna part 123 may be replaced by an electrically conductive metal stopper which is electrically connected with the rod antenna 124 within the cover 125. In such modified retractable transmitting antenna, when the movable antenna part is in its extended position, for example, as in Fig. 5B, an electrical circuit for powering the rod antenna 124 is established from transmitting path 102, through antenna clip 114, mounting socket 112 to hub 127 of disc 126 which is contacted by the noted metal stopper that replaces insulating stopper 133. In this case also, when the retractable transmitting antenna is in its extended position, both the helical antenna 121 and the rod antenna 124 are powered and the rod antenna 124 mainly operates as a monopole antenna which has its ground level at the ground of the shielding case conventionally provided within the housing 101c and the ground of the circuit board 110 therein, while the helical antenna 121, being continuously powered once again, is merely operable as an accessory of the rod antenna 124 in the extended position of the latter.

It will be appreciated that the cellular phone 100c is used in essentially the same manner as the

previously described cellular phones 100a and 100b with similar advantages being derived from its use of separate transmitting and receiving antennas 104c and 105a, respectively. However, the retractable transmitting
5 antenna 104c is further advantageous in that, it can have a substantial effective length when in its extended position for providing desirable transmitting performance, and yet be stowed substantially within the main body portion 106 of the housing 101c when in its
10 retracted position so that the cellular phone 100c may be readily carried in a pocket or the like.

It is further to be understood that other known types of antennas can be used as the transmitting antenna in a cellular phone or other portable radio apparatus for
15 transmitting and receiving radio waves in respective transmitting and receiving band widths and which, in accordance with this invention, further have a receiving antenna separate from the transmitting antenna.

In each of the embodiments of the invention
20 heretofore specifically described, the receiving antenna 105a included in the swingable portion 107 of the housing which also contains the microphone 109 has consisted of a simple rod antenna. However, the effective electrical length of the receiving antenna may be made greater than
25 the physical length thereof for improving its performance in receiving radio waves without undesirably increasing the size of the swingable portion 107 of the housing required for containing the receiving antenna along with the microphone 109. For example, in Figs. 6A and 6B,
30 there is shown a cellular phone 100d in accordance with still another embodiment of this invention which is generally similar to the cellular phone 100a previously described with reference to Figs. 3A and 3B, with corresponding parts being identified by the same
35 reference numerals and description of such parts being omitted, while the receiving antenna 105d, which alone

distinguishes the cellular phone 100d from the cellular phone 100a, is specifically described below.

As shown in Figs. 6A and 6B, the receiving antenna 105d includes a metal rod antenna 140 which, at one end, is right-angularly bent and terminates in a cylindrical hub 116 which is rotatable in the metal socket 117 embedded in the main body portion 106 of the housing 101a adjacent the location 103a where the receiving path 103 exits from the housing. Such receiving path 103 is connected through a RF signal line 118 and an antenna clip 119 with the socket 117. The end of rod antenna 140 remote from the hub 116 is electrically connected with an end of a helical antenna 141 extending in axial alignment with the rod antenna 140. The connected together rod antenna 140 and helical antenna 141 are embedded in the plastic material of the swingable portion 107 of the housing 101a, and such swingable portion 107 further contains the microphone 109 at a position beyond the helical antenna 141. It will be appreciated that, by reason of the helical antenna 141 connected to the rod antenna 140, the physical length of the receiving antenna 105d is shorter than the effective electrical length of such antenna. By reason of the foregoing, the reception performance of the cellular phone 100d may be improved in comparison with the reception performance of the cellular phone 100a without substantially increasing the size of the swingable portion 107 of the housing 101a which is stowed against the main body portion 106 when the cellular phone is in its standby condition.

Although Figs. 6A and 6B show the receiving antenna 105d comprised of a rod antenna 140 and a helical antenna 141 used in a cellular phone 100d which, in accordance with this invention, also has a separate transmitting antenna 104a constituted by a fixed rod antenna element, it will be understood that other types of transmitting antennas can be used in combination with

the receiving antenna 105d. Thus, as shown in Figs. 7A and 7B, a cellular phone 100e in accordance of an embodiment of this invention may use the previously described receiving antenna 105d in an apparatus which is otherwise the same as the cellular phone 100b and has its several parts, other than the receiving antenna, identified by the same reference numerals used in Figs. 4A and 4B. Thus, the cellular phone 100e of Figs. 7A and 7B uses the fixed helical antenna 104b as a transmitting antenna in combination with the receiving antenna 105d made up of the rod antenna 140 and the helical antenna 141.

Similarly, in Figs. 8A and 8B, the receiving antenna 105d is shown used in a cellular phone 100f according to yet another embodiment of this invention which is otherwise the same as the cellular phone 100c of Figs. 5A and 5B. Thus, in the cellular phone 100f of Figs. 8A and 8B, the receiving antenna 105d comprised of the rod antenna 140 and the helical antenna 141 is combined with the retractable transmitting antenna 104c which, as earlier described, includes the fixed helical antenna 121 and the moveable antenna part 123 made up of the rod antenna 124 enveloped in the elongated cover 125.

It will be appreciated that receiving antennas in addition to those identified as antennas 105a and 105d, respectively, can be employed in combination with any of the transmitting antennas 104a, 104b and 104c, or with any additional known transmitting antennas in cellular phones or similar radio apparatus for transmitting and receiving radio waves in accordance with this invention. In such cellular phones and the like embodying the invention, the use of separate antennas for transmitting and receiving radio waves in respective bandwidths makes it possible to separate the transmitting and receiving paths within the apparatus so that the use of a duplexer is not required. Further, since the transmitting and receiving paths may be widely separated

from each other, leakage of the transmitting power from the transmitting path to the receiving path may be readily suppressed for avoiding cross modulation and the like. Furthermore, since the transmitting and receiving
5 antennas need cover only the band widths of the transmitting band and the receiving band, respectively, the designing of the antennas for optimum performance is facilitated. Moreover, by including the receiving antenna in the swingable portion 107 of the housing which
10 contains the microphone 109 and which, in its operative position, is widely spaced from the transmitting antenna, cellular phones embodying this invention may be readily employed in digital cellular phone systems without the occurrence of puncturing audio noise.

15 Although preferred embodiments of this invention and modifications thereof have been described in detail herein, it is to be understood that the invention is not limited thereto, and that various changes and further modifications may be effected by one
20 skilled in the art without departing from the scope or spirit of the invention as defined in the appended claims.

WHAT IS CLAIMED IS:

1. In a portable radio apparatus for transmitting and receiving radio waves in respective transmitting and receiving band widths, the combination
5 of:

a portable housing;
circuit means in said housing for processing transmitted and received radio waves, respectively, and including means defining a transmitting
10 path and a receiving path which are substantially spaced from each other within said housing and exit from the latter at respective substantially spaced apart locations; and

transmitting and receiving antennas
15 mounted on said housing at said substantially spaced apart locations and being there connected with said transmitting and receiving paths, respectively, said transmitting and receiving antennas being configured for transmitting and receiving radio waves substantially only
20 in said transmitting and receiving band widths, respectively.

2. A portable radio apparatus according to claim 1; further comprising a loudspeaker and a microphone; and in which said housing includes a main
25 body portion containing said loudspeaker, and a swingable portion containing said microphone and pivoted in respect to said main body portion for movement between a stowed position where said swingable portion lies substantially flat against said main body portion and an operative
30 position where said swingable portion extends from said main body portion for disposing said microphone at a desired distance from said loudspeaker; and further in which one of said antennas extends from said main body portion of the housing and the other of said antennas is
35 included in said swingable portion of the housing for maximum spacing of said antennas from each other when

said swingable portion is in said operative position thereof.

3. A portable radio apparatus according to claim 2; in which said apparatus is for use in a digital cellular phone system; and in which said transmitting antenna is said one antenna extending from said main body portion and said receiving antenna is said other antenna included in said swingable portion of the housing containing said microphone which is thereby substantially distanced from said transmitting antenna for discouraging signal leakage from said transmitting antenna to said microphone and consequent puncturing audio noise.

4. A portable radio apparatus according to claim 3; in which said main body portion and said swingable portion of said housing are of a molded plastic material; and said receiving antenna includes a monopole rod antenna element of metal embedded in said plastic material of the swingable portion for strengthening the latter.

5. A portable radio apparatus according to claim 3; in which said transmitting antenna extends from said location at which said transmitting path exits from said body portion of the housing in a direction away from said location at which said receiving path exits from the main body portion of said housing; and in which said swingable portion is pivoted about an axis passing through said location at which said receiving path exits from said main body portion; and further in which said receiving antenna includes a monopole rod antenna element extending from said axis and having said microphone disposed beyond an end of said monopole rod antenna element which is remote from said axis for optimum spacing of said microphone from said transmitting antenna when said swingable portion of the housing is in said operative position.

6. A portable radio apparatus according to claim 5; in which said receiving antenna further includes

a helical antenna portion electrically connected to said end of the rod antenna element to provide said receiving antenna with an effective electrical length substantially greater than the physical length thereof.

5 7. A portable radio apparatus according to claim 6; in which said transmitting antenna is a monopole antenna extending fixedly from said main body portion of the housing.

10 8. A portable radio apparatus according to claim 6; in which said transmitting antenna is a helical antenna extending fixedly from said main body portion of the housing.

15 9. A portable radio apparatus according to claim 6; in which said transmitting antenna includes a helical antenna element extending fixedly from said main body portion of the housing and being continuously connected electrically with said circuit means, a rod antenna element extending in the direction of the axis of said helical antenna element and being movable relative
20 to the latter between a retracted position, in which said rod antenna element is removed from within said helical antenna element into the interior of said main body portion of the housing, and an extended position, in which said rod antenna element extends through said
25 helical antenna element to the exterior of said housing, and means for powering said rod antenna element with said helical antenna element when said rod antenna element is in said extended position so as to act principally as a radiator.

30 10. A portable radio apparatus according to claim 9; in which said rod antenna element is electromagnetically coupled with said helical antenna element when in said extended position for achieving said powering of the rod antenna element.

35 11. A portable radio apparatus according to claim 9; in which said means for powering said rod antenna element provides an electrical connection between

the latter and said circuit means when said rod antenna element is in said extended position.

12. A portable radio apparatus according to claim 2; in which said main body portion and said swingable portion of said housing are of a molded plastic material; and said other antenna includes a monopole rod antenna element of metal embedded in said plastic material of the swingable portion of said housing for strengthening the latter.

10 13. A portable radio apparatus according to claim 5; in which said transmitting antenna is a monopole antenna extending fixedly from said main body portion of the housing.

15 14. A portable radio apparatus according to claim 5; in which said transmitting antenna is a helical antenna extending fixedly from said main body portion of the housing.

20 15. A portable radio apparatus according to claim 5; in which said transmitting antenna includes a helical antenna element extending fixedly from said main body portion of the housing and being continuously connected electrically with said circuit means, a rod antenna element extending in the direction of the axis of said helical antenna element and being movable relative to the latter between a retracted position, in which said rod antenna element is removed from within said helical antenna element into the interior of said main body portion of the housing, and an extended position, in which said rod antenna element extends through said helical antenna element to the exterior of said housing, and means for powering said rod antenna element with said helical antenna element when said rod antenna element is in said extended position so as to act principally as a radiator.

35 16. A portable radio apparatus according to claim 15; in which said rod antenna element is electromagnetically coupled with said helical antenna

element when in said extended position for achieving said powering of the rod antenna element.

17. A portable radio apparatus according to claim 15; in which said means for powering said rod antenna element provides an electrical connection between said circuit means and said rod antenna element when the latter is in said extended position.

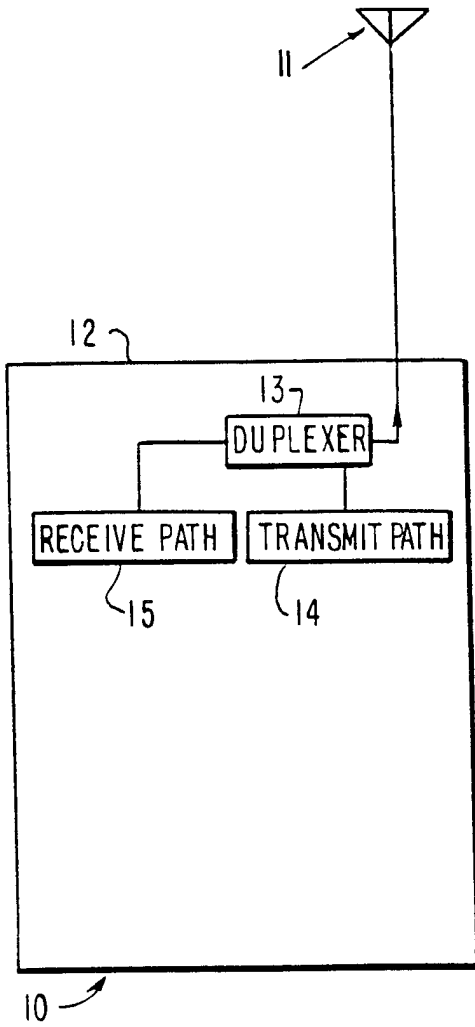

FIG. 1
(PRIOR ART)

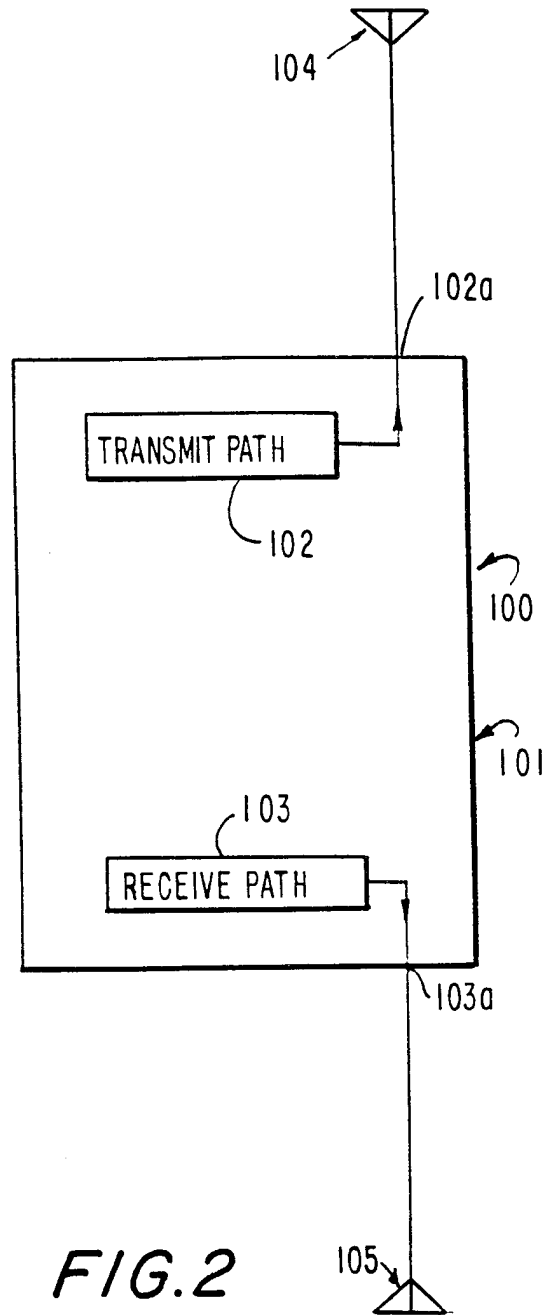

FIG. 2

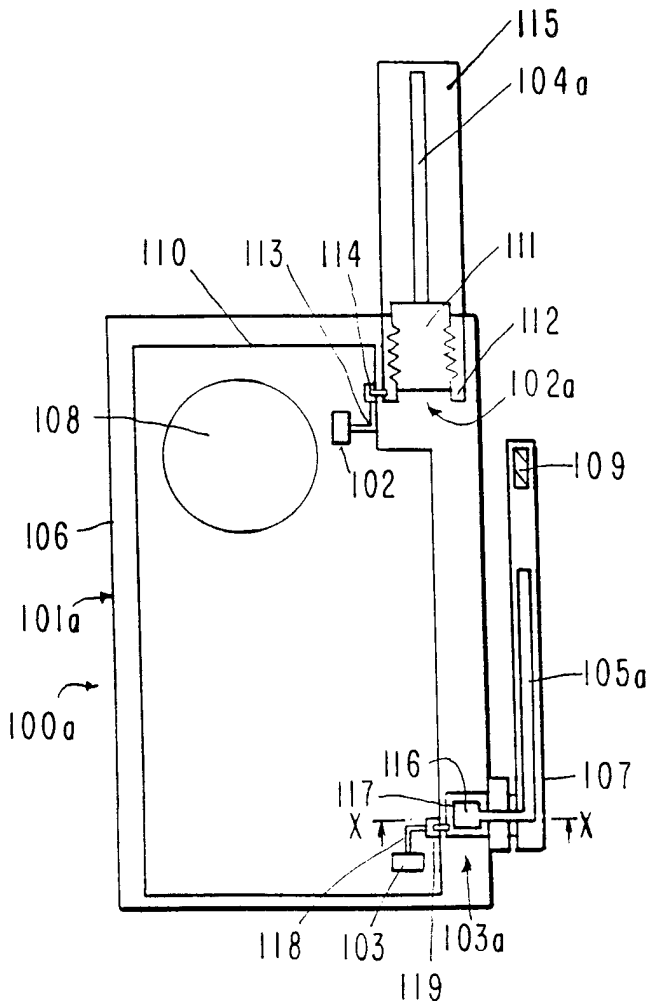

FIG. 3A

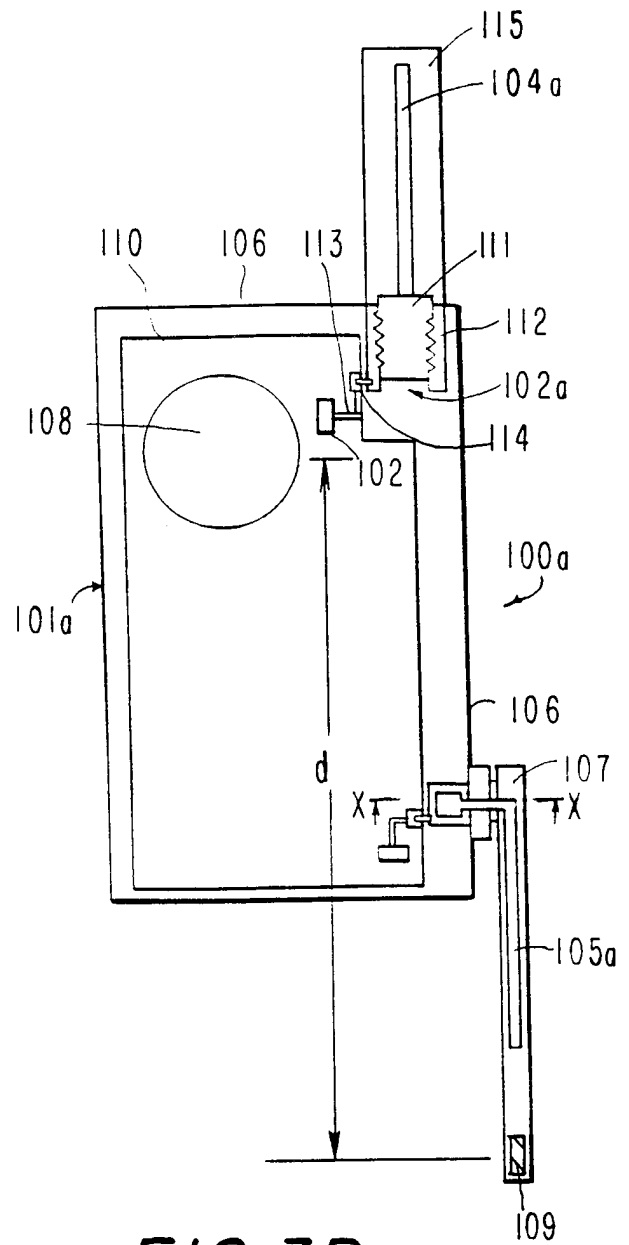

FIG. 3B

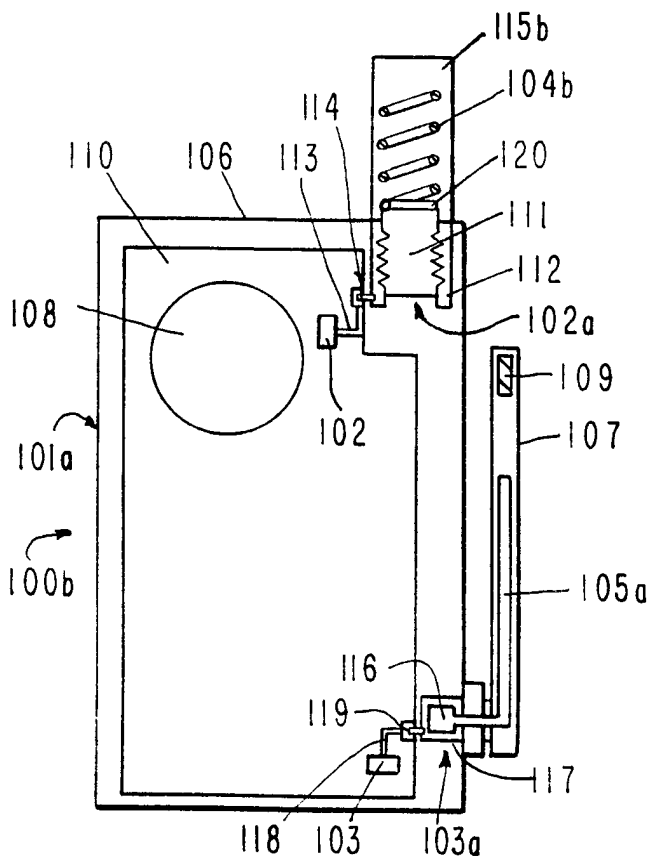

FIG. 4A

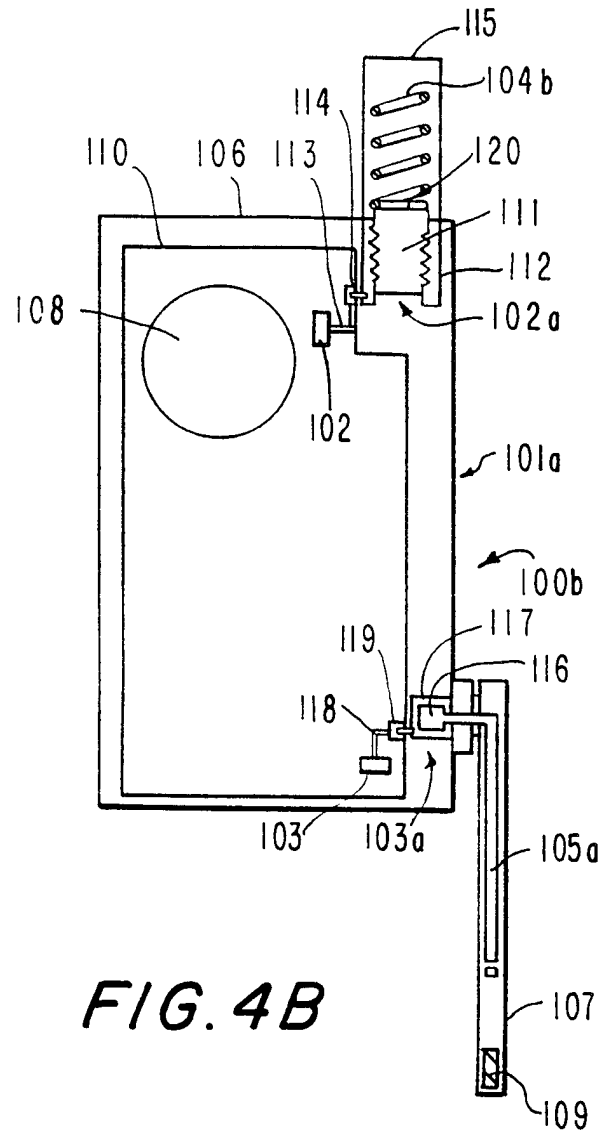

FIG. 4B

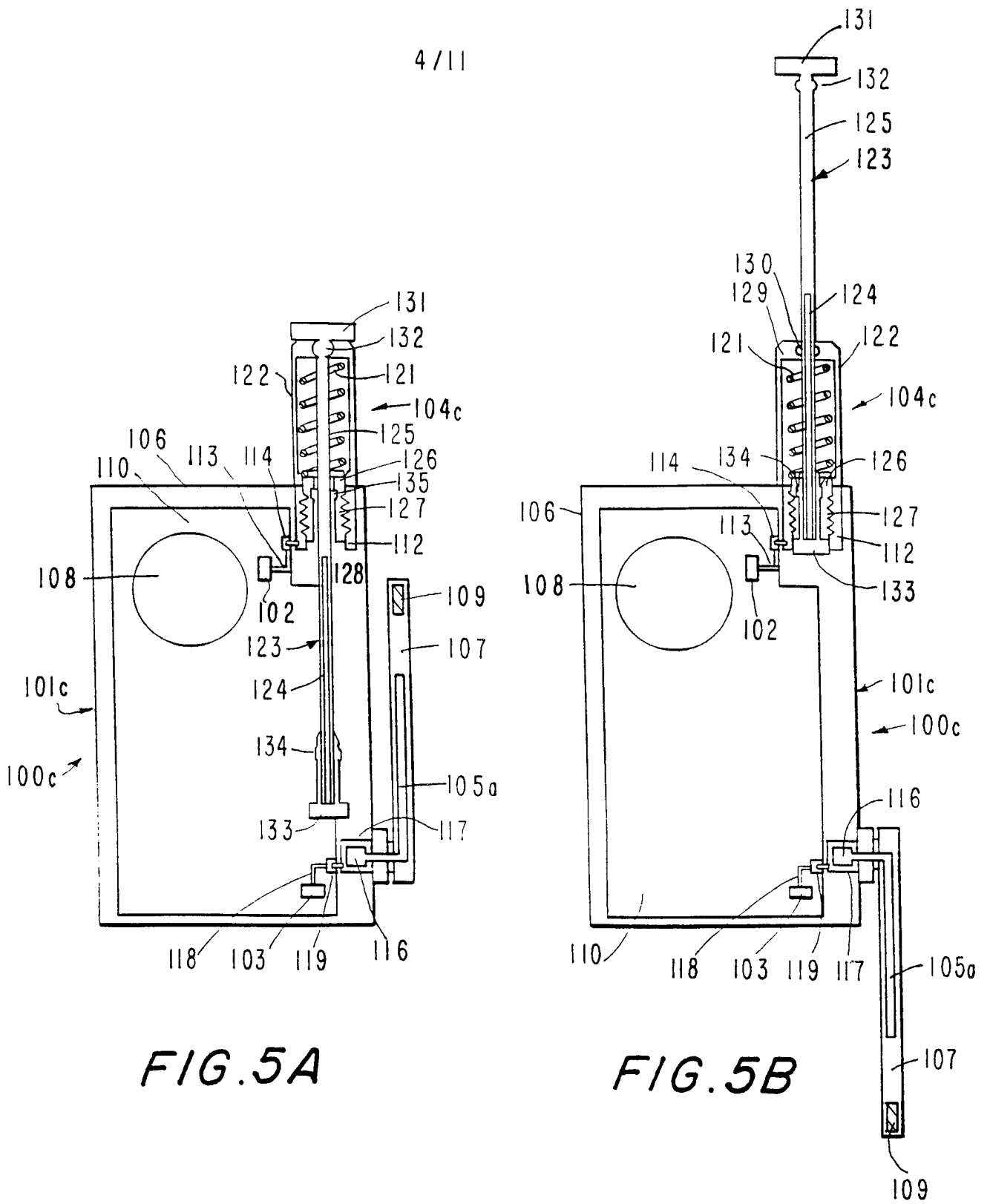

FIG. 5A

FIG. 5B

5/11

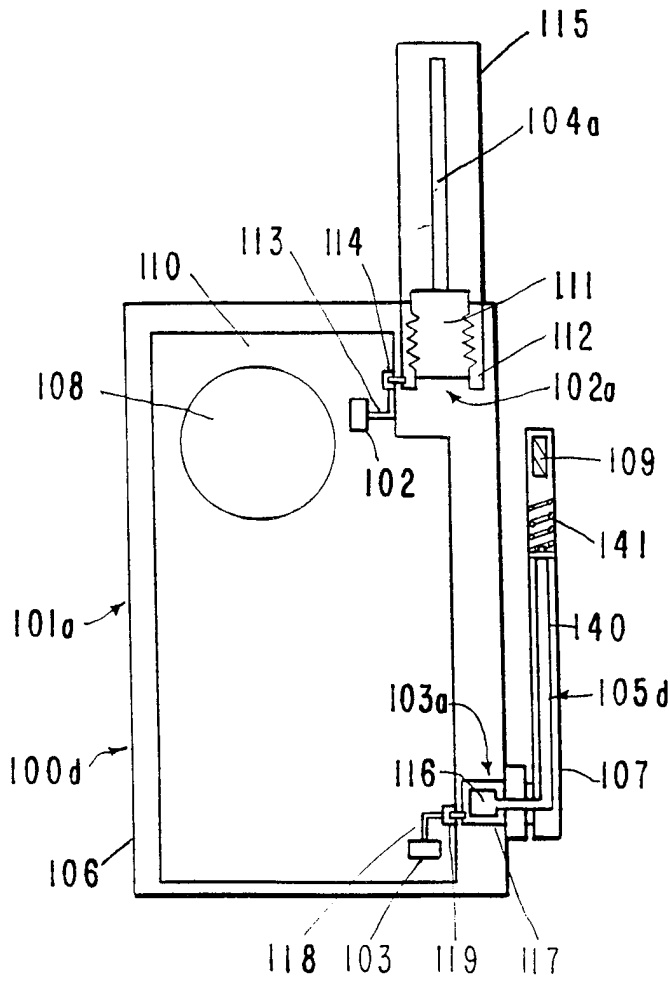

FIG. 6A

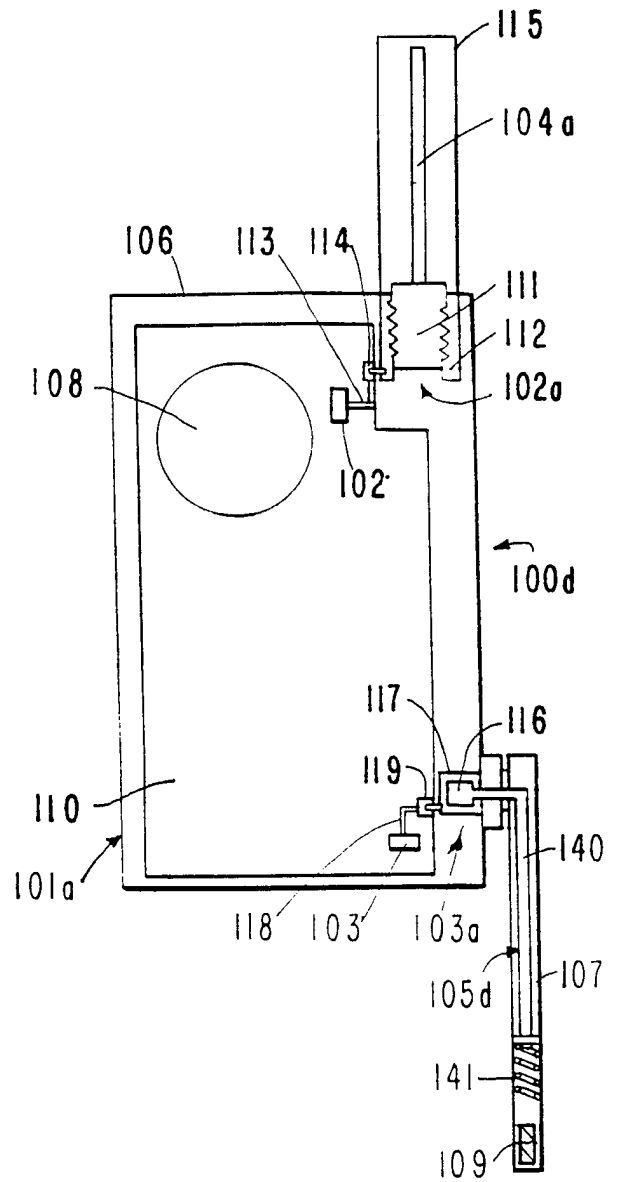

FIG. 6B

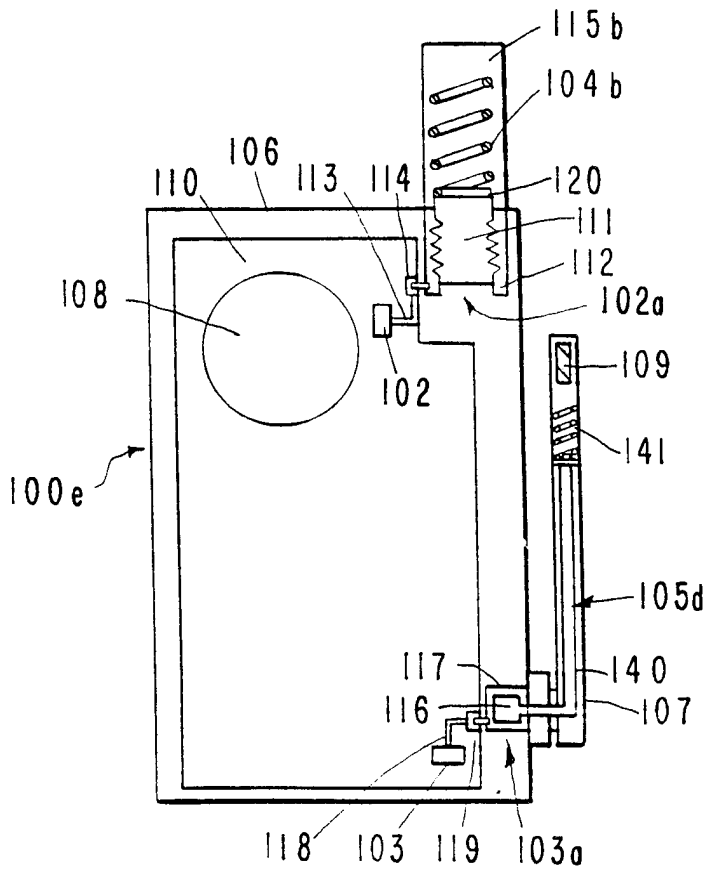

FIG. 7A

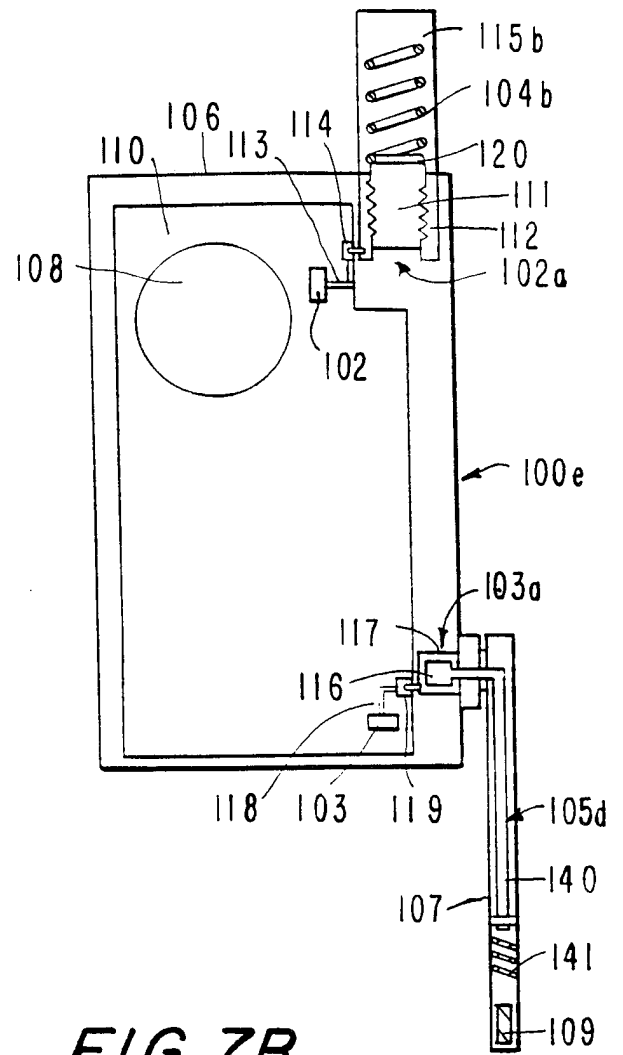

FIG. 7B

7 / 11

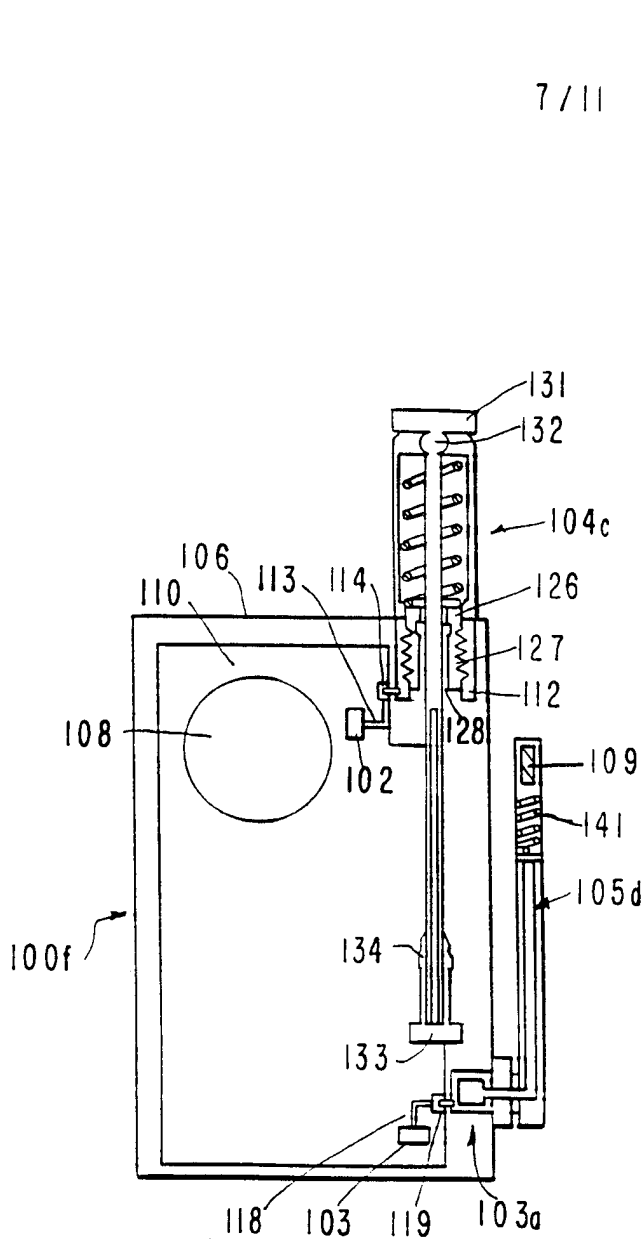

FIG. 8A

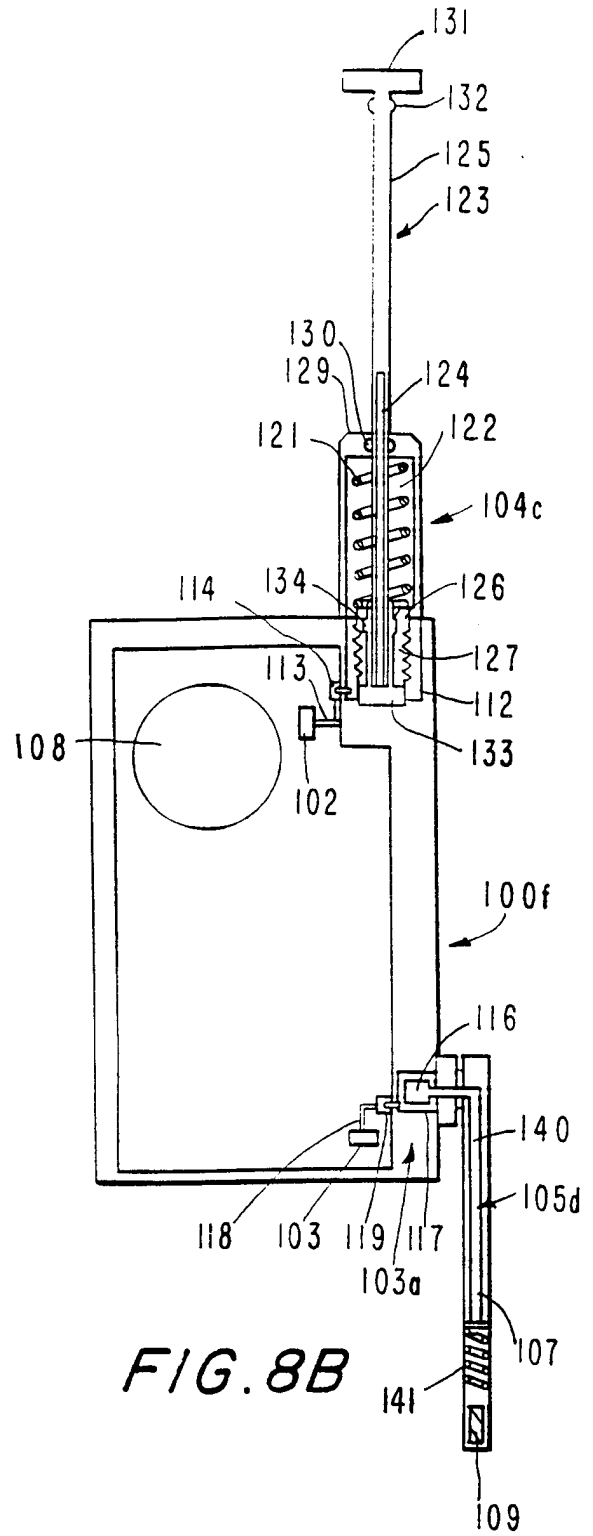
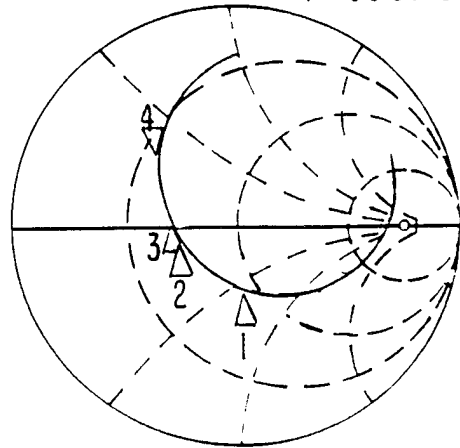

FIG. 8B

8/11

4. 21.402 15.438 1.2347 nH

1 990.000.000 MHz



- 1. 44.318
30.568
1.85 GHz
- 2. 29.538
4.1104
1.91 GHz
- 3. 27.311
1.6543
1.93 GHz

SWR

1 / REF 1

4 2.6025

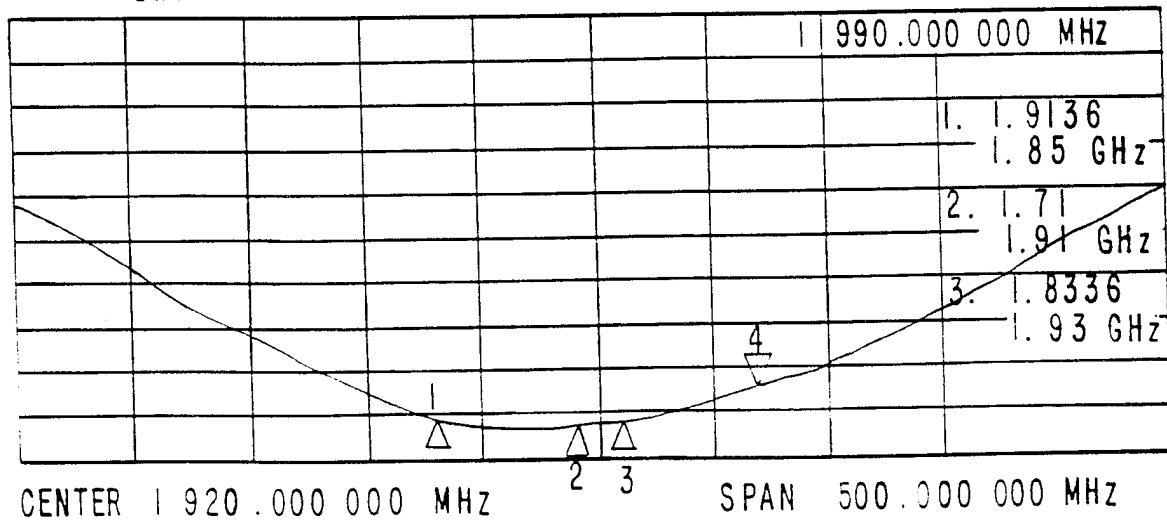
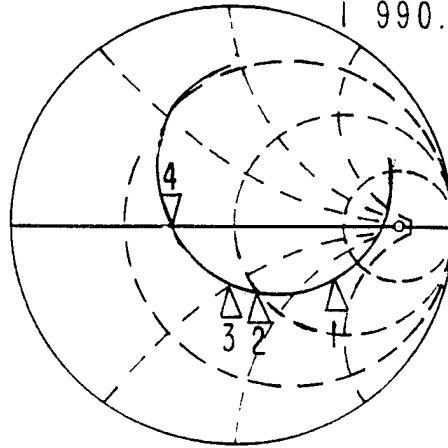

FIG. 9A

9/11

4. 26.014 -632.81 m 126.38 pF
| 990.000 000 MHz



- 1. 107.04
-62.977
1.85 GHz
- 2. 49.879
-32.201
1.91 GHz
- 3. 41.146
-23.148
1.93 GHz

SWR | / REF | 4 1.9225

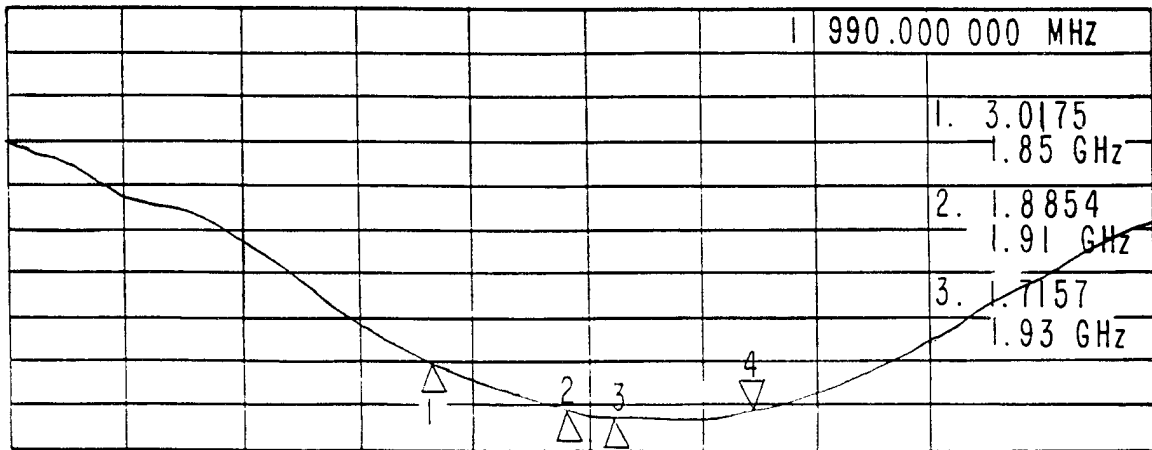

CENTER | 920.000 000 MHz SPAN 500.000 000 MHz

FIG. 9B

10/11

4. 77.77 Ω 21.941 Ω 1.7548 nH
1990.000 000 MHz

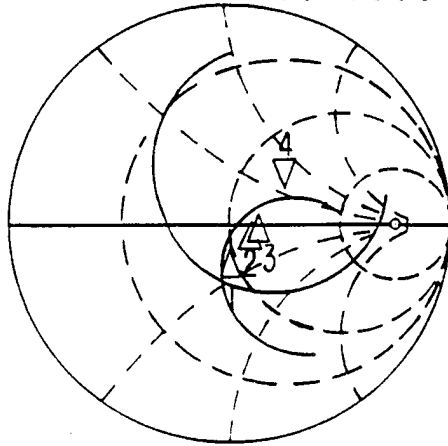

- 1. 46.076 Ω
9.2188 Ω
1.85 GHz
- 2. 58.041 Ω
4.8594 Ω
1.91 GHz
- 3. 62.105 Ω
7.502 Ω
1.93 GHz

SWR

| / REF |

4 1.7511

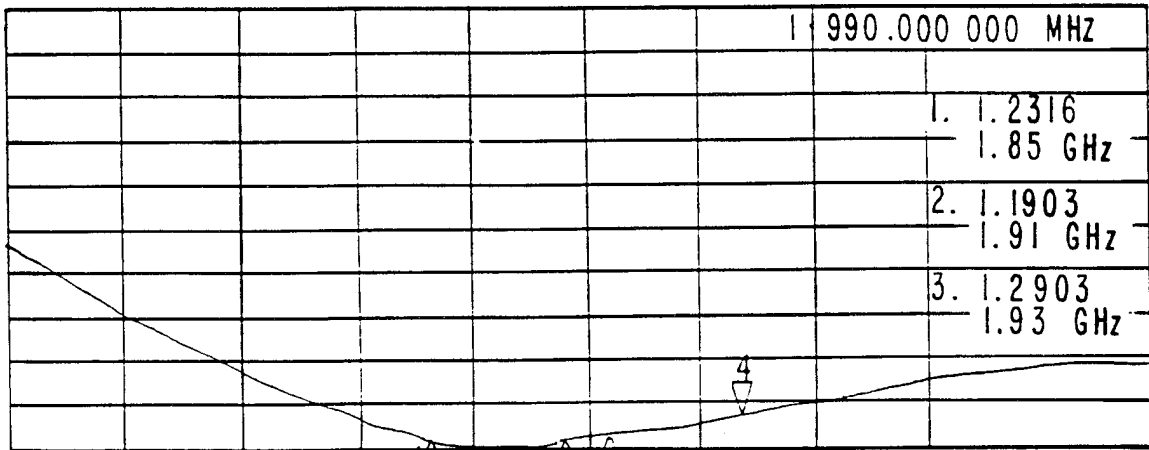

1990.000 000 MHz

- 1. 1.2316
1.85 GHz
- 2. 1.1903
1.91 GHz
- 3. 1.2903
1.93 GHz

CENTER 1920.000 000 MHz 2 3 SPAN 500.000 000 MHz

FIG. 10A

11/11

4.84.805Ω 19.707Ω 1.5761 nH
1990.000 000 MHz

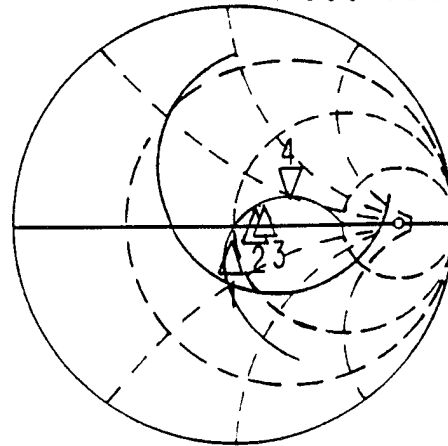

- 1. 48.563Ω
8.207 Ω
1.85 GHz
- 2. 61.275Ω
7.7187Ω
1.91 GHz
- 3. 67.285Ω
11.75 Ω
1.93 GHz

SWR | / REF | 4 1.8312

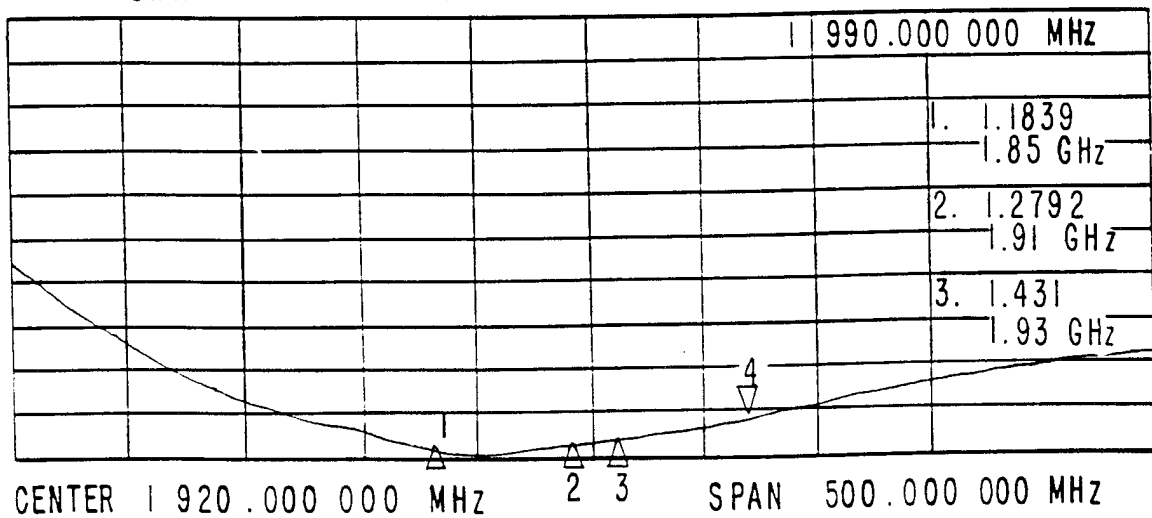

FIG.10B

INTERNATIONAL SEARCH REPORT

International application No.
PCT/US98/09645

A. CLASSIFICATION OF SUBJECT MATTER
 IPC(6) : H04B 1/44, 1/38; H01Q 1/24
 US CL : 455/ 78, 562, 575; 343/702
 According to International Patent Classification (IPC) or to both national classification and IPC

B. FIELDS SEARCHED
 Minimum documentation searched (classification system followed by classification symbols)
 U.S. : 455/ 78, 562, 575; 343/702

Documentation searched other than minimum documentation to the extent that such documents are included in the fields searched
 NONE

Electronic data base consulted during the international search (name of data base and, where practicable, search terms used)
 APS

C. DOCUMENTS CONSIDERED TO BE RELEVANT

Category*	Citation of document, with indication, where appropriate, of the relevant passages	Relevant to claim No.
Y	US 5,170,173 A (Krenz et al) 10 December 1992, figures 1, 3 & 4; col. 1, line 63 - col. 2, line 11; col. 3, lines 1-7.	1-5, 12-14
Y	US 5,564,078 A (Nagai) 08 October 1996, figure 2; col. 2, line 57 - col. 3, line 23.	2,3,5,13
Y, E	US 5,649,306 A (Vannatta et al) 15 July 1997, col. 4, lines 41-49; col. 4, lines 65-67.	5, 14

Further documents are listed in the continuation of Box C. See patent family annex.

* Special categories of cited documents:	** later document published after the international filing date or priority date and not in conflict with the application but cited to understand the principle or theory underlying the invention
A document defining the general state of the art which is not considered to be of particular relevance	*X* document of particular relevance; the claimed invention cannot be considered novel or cannot be considered to involve an inventive step when the document is taken alone
E earlier document published on or after the international filing date	*Y* document of particular relevance; the claimed invention cannot be considered to involve an inventive step when the document is combined with one or more other such documents, such combination being obvious to a person skilled in the art
L document which may throw doubts on priority claim(s) or which is cited to establish the publication date of another citation or other special reason (as specified)	*G* document member of the same patent family
O document referring to an oral disclosure, use, exhibition or other means	
P document published prior to the international filing date but later than the priority date claimed	

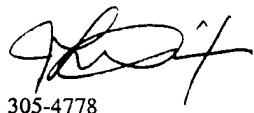
Date of the actual completion of the international search 13 SEPTEMBER 1998	Date of mailing of the international search report 14 OCT 1998
Name and mailing address of the ISA/US Commissioner of Patents and Trademarks Box PCT Washington, D.C. 20231 Facsimile No. (703) 305-3230	Authorized officer DWAYNE BOST  Telephone No. (703) 305-4778