

March 27, 1934.

R. V. REPPERT

1,952,893

SWITCH

Filed June 18, 1931

4 Sheets-Sheet 1

FIG. 1.

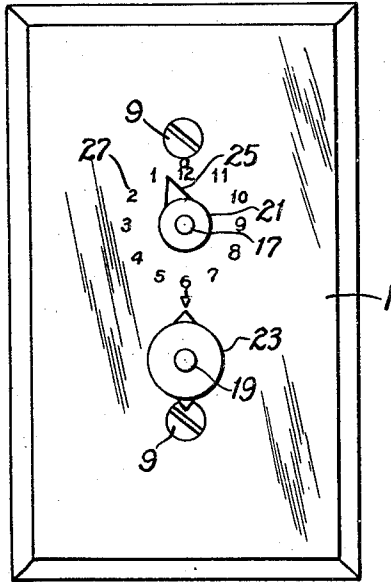
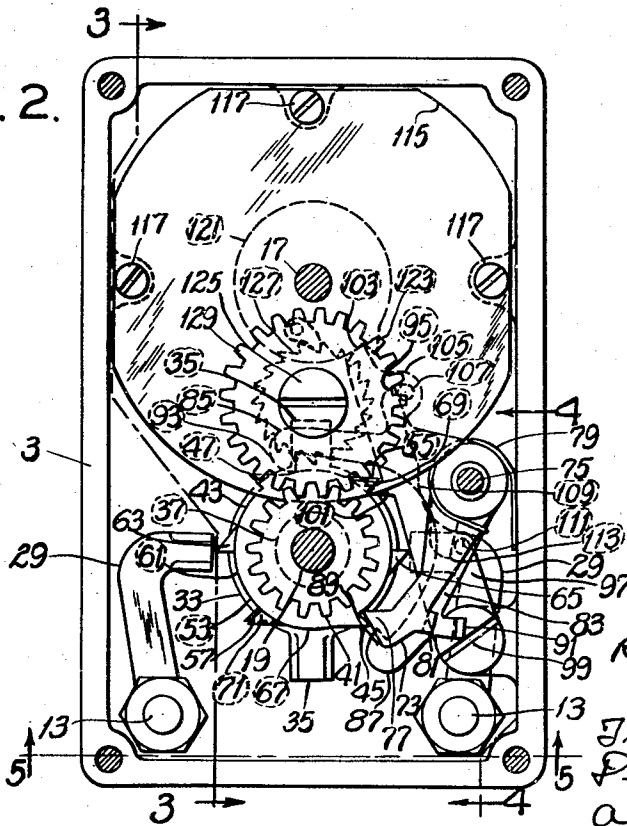

FIG. 2.



Richard V.
Reppert,
Inventor,
Pelos S. Haynes,
Attorney

March 27, 1934.

R. V. REPERT

1,952,893

SWITCH

Filed June 18, 1931

4 Sheets-Sheet 2

FIG. 3.

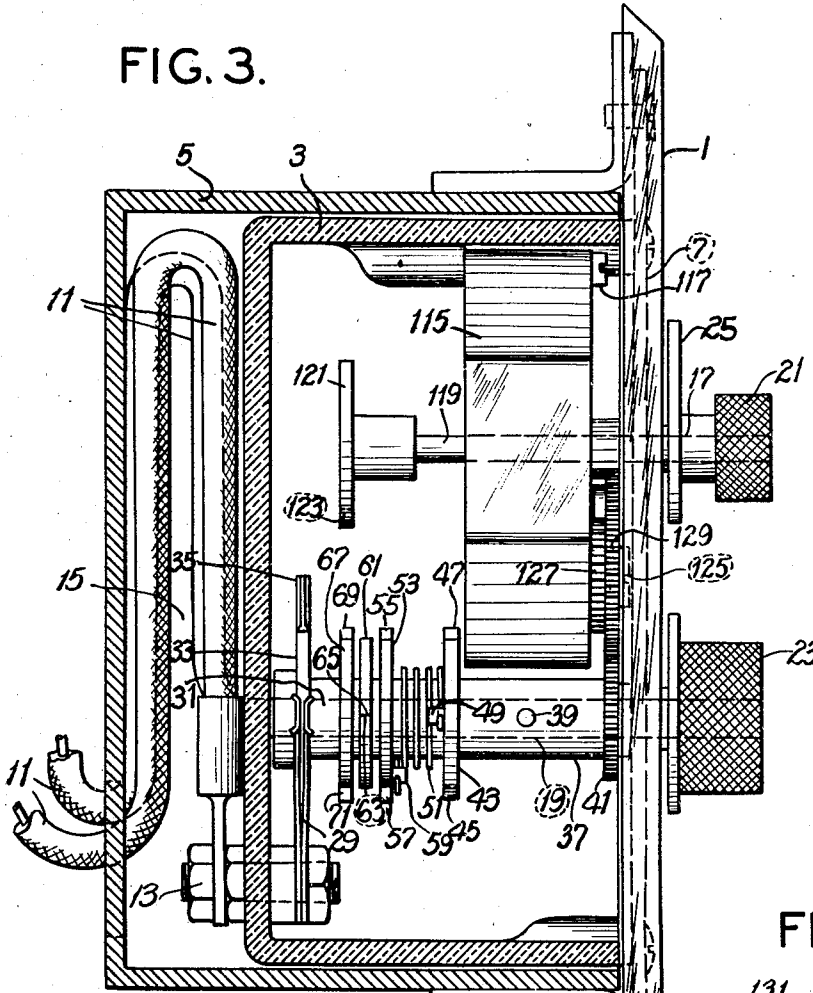

FIG. 7.

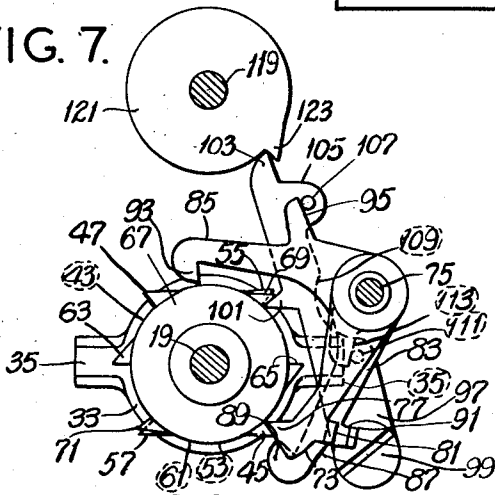
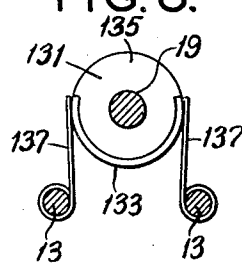

FIG. 8.



Richard V. Repert,
Inventor.
Dolan V. Haynes,
Attorney

March 27, 1934.

R. V. REPERT

1,952,893

SWITCH

Filed June 18, 1931

4 Sheets-Sheet 3

FIG. 4.

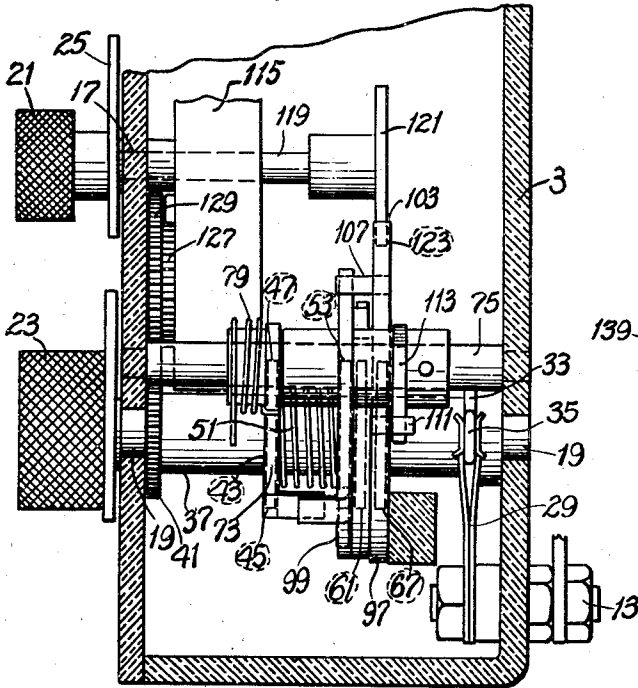

FIG. 9.

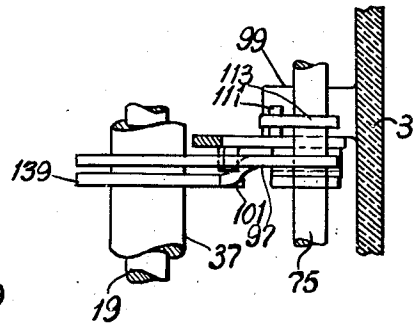
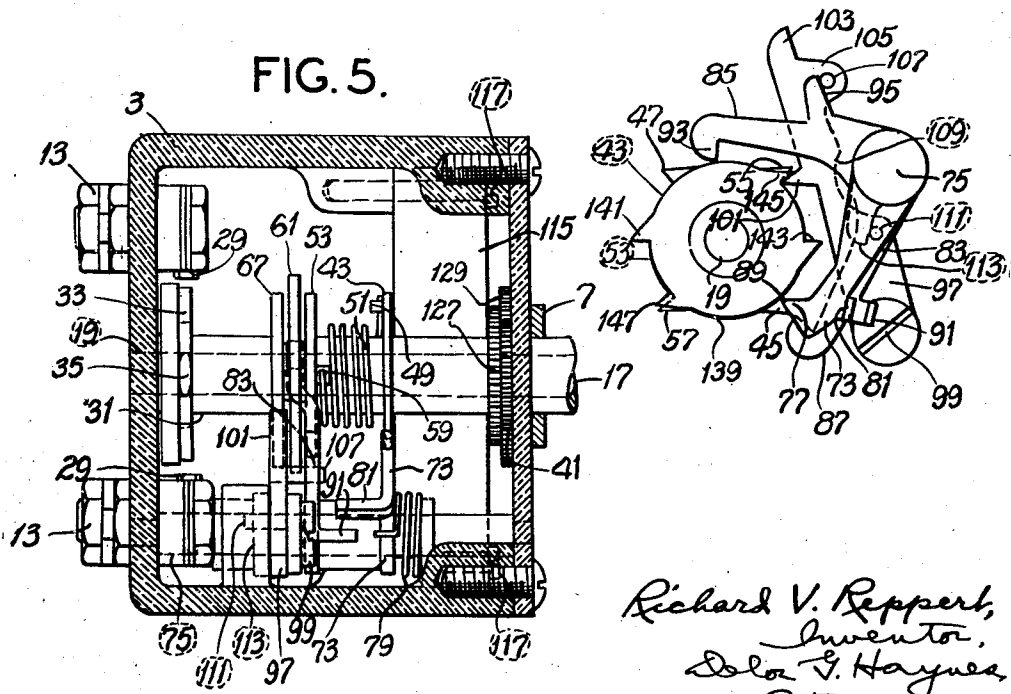

FIG. 10.



Richard V. Reppert,
Inventor,
Dora S. Haynes,
Attorney

UNITED STATES PATENT OFFICE

1,952,893

SWITCH

Richard V. Reppert, West Hartford, Conn., assignor to M. H. Rhodes, Inc., Hartford, Conn., a corporation of Delaware

Application June 18, 1931, Serial No. 545,201

10 Claims. (Cl. 200—39)

This invention relates to switches, and with regard to certain more specific features to time controlled delayed action switches.

Among the several objects of the invention may be noted the provision of a switch of the class described which permits of setting to any desired time delay, in a constantly adjustable manner, as contrasted to a switch designed for setting only to definite intervals or multiplications thereof; a switch of the class described in which readjustment is effected with facility even after an original setting is made, and without necessity of operating the switch per se; a switch of the class described wherein no great strain is placed upon the clockwork per se in throwing the switch per se; and a switch of the class described wherein winding of the clockwork is achieved simultaneously with the manipulation of the switch. Other objects will be in part obvious and in part pointed out hereinafter.

The invention accordingly comprises the elements and combinations of elements, features of construction, and arrangements of parts which will be exemplified in the structure hereinafter described, and the scope of the application of which will be indicated in the following claims.

In the accompanying drawings, in which are illustrated several of various possible embodiments of the invention,

Fig. 1 is a front elevation of a switch embodying the invention;

Fig. 2 is likewise a front elevation of a switch embodying the invention, but having certain parts removed;

Fig. 3 is a vertical section taken substantially on line 3—3 of Fig. 2;

Fig. 4 is a vertical section taken substantially on line 4—4 of Fig. 2;

Fig. 5 is a horizontal section taken substantially on line 5—5 of Fig. 2;

Fig. 6 is a diagrammatic composite view, illustrating the positions of various elements at various stages of operation of the switch;

Fig. 7 is a diagrammatic view similar to part of Fig. 6, illustrating an alternative embodiment of the invention;

Fig. 8 is a diagrammatic view of an alternative form of connector;

Fig. 9 is a fragmentary horizontal section, similar to a portion of Fig. 5, illustrating a second alternative embodiment of the invention; and,

Fig. 10 is a view similar to Fig. 7, but relating to the embodiment shown in Fig. 9.

For descriptive purposes, the switch is advantageously divided into the following sections:

(1) the exterior housing and supports, (2) the electrical connecting means, (3) the motivating means, and, (4) the time controlling means. These sections will be described separately so far as practical, and then considered together in the operation of the switch as a whole.

The exterior housing and supports

Referring now more particularly to Figs. 1 and 3, there is indicated at numeral 1 a flush face plate of the type in general use for the wall mounting of switches. Numeral 3 indicates a housing or casing, formed preferably of insulating material. The casing 3 is secured in an ordinary wall switch box 5 by means of a strap 7, to which the face plate 1 is likewise secured, by screws 9. Customary electrical conductors 11 connect to terminals 13 on the casing 3. A space 15 at the rear of the box 5 allows room for excess lengths of conductors 11.

From the interior of the housing 3 two shafts 17 and 19 project through the face plate 1, and are provided at their extremities with knobs 21 and 23, respectively. The knob 21 includes a pointer 25, which indicates values on a scale 27 struck or otherwise formed on the surface of the face plate 1.

The electrical connecting means

The interior of the housing 3 contains substantially all of the working parts of the switch. The exterior terminal pieces 13 extend in the housing, and are provided each with a spring-clip contactor 29, (see Figs. 2, 3, 4 and 5).

The lower shaft 19 is journaled at its inner end in the casing 3, and carries thereon, toward the rear, a rotatable sleeve 31. On the sleeve 31, in the plane of the contactors 29, is fixed an insulating disc 33, carrying conducting ears 35 spaced 180° apart and electrically connected. When the sleeve 31 rotates on the shaft 19, it will be seen that the ears 35 rotate into and out of connection with the spring contactors 29, thus making and breaking electrical connections across the exterior terminals 13. It will be noted that there are two positions of contact, separated 180°, for each complete revolution of the sleeve 31.

The motivating means

The motivating means comprise the majority of the parts of the switch as a whole. Reference is directed to Figs. 2, 3, 4, and 5 for the following description.

Numerical 37 (Figs. 3, 4 and 5) indicates a sleeve or collar which is pinned to the shaft 19 as at 39.

At its front (face-plate) end, the collar 37 carries a gear 41, which is operative to wind the clockwork mechanism as will be more fully described hereinafter. The rear end of the collar 37 similarly carries a cam disc 43, which has two projections or ears 45 and 47 thereon, spaced 180° apart. The ears 45 and 47 are in the plane of the disc 43. A third projection 49, at right angles to the plane of the disc 43, engages one end of a torsional spring 51.

Abutting the rear end of the collar 37, preferably in a frictionless manner, is the front end of the rotatable sleeve 31. Mounted immovably on the sleeve 31 are three common centered discs 53, 61, and 67, progressing rearwardly. The disc 53 has two ears or projections 55 and 57, 180° apart, in its own plane, and a third projection 59 facing front at right angles to its plane. The projection 59 engages the other end of the torsional spring 51 (the one end being held, as described, by projection 49 on disc 43). Discs 61 and 67 have coplanar ears or projections 63 and 65, and 69 and 71, respectively, spaced 180° apart, respectively. Ears 69 and 71 are angularly disposed like, and face the same way as ears 55 and 57. Ears 63 and 65 face oppositely, and are angularly advanced the order of 50° from ears 55 and 57. Ears 63 and 65 face the same way as ears 45 and 47 on disc 43.

It will be seen that manual rotation of the knob 23 turns the collar 37 directly (and thus turns the disc 43 directly), and, through the torsion spring 51, turns the sleeve 31 (and thus the discs 53, 61, and 67). Such rotation is utilized to effect an escapement, or regulated motion, of the contactor disc 33.

In the same plane as the disc 43 is provided a swingable lever or detent 73, which is keyed upon a shaft 75 journaled at its ends in the housing 3. The detent 73 has at its end a projection 77 which engages with the ears 45 and 47 on the disc 43. A torsional spring 79 on the shaft 75 (fixed at one end to the housing 3) holds the projection 77 normally against the periphery of the disc 43. Struck at right angles from the plane of the detent 73 is a projection 81, the utility whereof will appear hereinafter.

Also mounted on the shaft 75 is a second lever 83, comprising upper arm 85 and lower arm 87. The lever 83 is free to rotate on the shaft 75. The lower arm 87 is in the plane of the disc 53, and has at its extremity a hook 89 adapted for engagement with the projections 55 and 57. Struck at right angles from the arm 87 is a projection 91, which engages the projection 81 from the detent 73, as will appear more fully hereinafter.

The upper arm 85 of the lever 83 is in the plane of the disc 61, and has at its extremity a cam end 93, adapted for engagement with the projections 63 and 65 on said disc 61. On the upper edge of the arm 85 is a cam extension 95.

The arms 85 and 87 are angularly positioned, relative to each other, so that when the extremity of either arm is touching the periphery of its disc, the other arm is held far enough from its disc just to clear the respective projections thereon.

A lever 97 is provided in the plane of disc 67. Lever 97 is rotated about a suitable center such as that indicated at numeral 99, and extends in a general upward direction. The lever 97 has thereon a series of projections, the first of which, indicated at numeral 101, engages the projections 69 and 71 on disc 67. A second projection 103 engages the timing mechanism yet to be described.

A third projection 105 carries a pin 107 at right angles thereto which, upon suitable occasion, engages the cam surface of the extension 95 on the arm 85 of lever 83.

A hollowed-out portion 109 on the lever 97 prevents said lever from locking against the shaft 75 in any operating position. Below said portion 109 a pin 111 is mounted, at right angles to the plane of the lever 97.

Reacting against the pin 111 is a cam 113, keyed or otherwise non-rotatably affixed to the shaft 75.

The time controlling means

Referring to Figs. 2, 3, and 4, numeral 115 indicates a clockwork mechanism, which may comprise any suitably sized standard construction time piece. The clock 115 is held to the housing 3 by suitable mounting screws 117. Depending upon whether a long-time or a short-time operating switch is desired, the minute or hour hand of the clock 115 is removed (the dial of the clock being also preferably removed). The shaft 17 is then coupled to the hour or minute hand shaft of the clock, as the case may be, by a frictional contact. An extension shaft 119 is similarly coupled to the same hour or minute hand shaft, and extends rearwardly into the housing 3. At the end of the extension shaft 119 is non-rotatably mounted a disc 121 having a single projection 123 thereon. The projection 123 engages the projection 103 of the lever 97.

The usual winding mechanism of the clock, comprising a shaft 125 having a ratchet 127 thereon, is disposed at the front thereof, and a gear 129 is mounted on the shaft 125 to mesh with the gear 41 mounted on collar 37 on the main shaft 19. Through this arrangement, winding of the clock is achieved by manipulation of the knob 23, while setting thereof is accomplished by the manipulation of knob 21, as indicated by the pointer 25 on the scale 27 on face plate 1.

Operation

Operation of the switch as a whole is desirably described by reference to Fig. 6. Fig. 6 comprises a series of diagrammatic views, indicated as "A" to "T", respectively, illustrating the positioning of various elements at succeeding stages of operation. The top horizontal rank of views (A, B, C, D) illustrates the assembled parts. The second horizontal rank (E, F, G, H) concerns more particularly the disc 67 and the lever 97. The third horizontal rank (I, J, K, L) concerns the disc 61 and arm 85 of lever 83. The fourth horizontal rank (M, N, O, P) concerns the disc 53 and arm 87 of lever 83. The bottom horizontal rank (Q, R, S, T) concerns the contactor disc 33.

The left-hand vertical file of views (A, E, I, M, Q) illustrates the various elements at an arbitrary normal position. The second vertical file (B, F, J, N, R) illustrates an advanced position. The third vertical file (C, G, K, O, S) illustrates a still more advanced position. The fourth right-hand vertical file (D, H, L, P, T) illustrates an advanced position, whence the elements return to the position of the first file.

Normal or initial position, as illustrated in views A, E, I, M, and Q, is as follows:

The clock 115 is at "zero" setting, whereby the disc 121 (view A) is rotated so that the projection 123 engages the end 103 of lever 97 and rotates it in a counterclockwise direction, thus bringing the projection 101 into the path of pro-

jection 69 or 71 on disc 67 (view E). At the same time, pin 107 on lever 97 bears against cam 95 on arm 85 of lever 83, and pushes said lever 83 down so that the end 93 thereof is in position to be engaged by the projections 63 and 65 on disc 61 (view I). Moving of the arm 85 likewise moves the arm 87 of lever 83, and rotates the hook end 89 out of the path of projections 55 and 57 on disc 53 (view M). The contactor disc 33 is simultaneously positioned in a contact "off" position (view Q). The disc 43 (view A) is not moved by the rotation of disc 121, but is held in stationary position, under the reaction of initially tensioned spring 51, by the engagement of detent 73 with projection 45 (or 47) on said disc 43. This comprises the normal position of the switch.

The first operation comprises a winding of the clockwork 115 accomplished by manually rotating the knob 23 in a clockwise direction, thus rotating the gears 41 and 129 and the ratchet 127.

With the winding, the following movements take place:

The disc 43 rotates, say 180° , by the manipulation of knob 23. At a point somewhat less than 180° , the projection 47 cams against the end 77 of detent 73, pushing the detent 73 aside (view B). The discs 53, 61, and 67 are held from rotating by the engagement of projections 69 and 101 (view F.) Thus the discs 33, 53, 61, and 67 remain in normal position (views F, J, N, and R). The spring 51 is accordingly placed under greater-than-initial tension.

However, the movement of detent 73 occasions rotation of the shaft 75, and movement of the cam 113. The edge of the cam 113 acts on the pin 111 on lever 97, and rotates said lever 97 in a clockwise direction (view F).

When the rotation of the knob 23 equals 180° , the following changes take place.

The end 77 of the detent 73 springs back against the periphery of the disc 43, and prevents said disc from rotating backwardly by engagement with the flat side of projection 47 (view C). Meanwhile the cam 113 has pushed the lever 97 (and thus the projection 101) out of engagement with projection 69 on disc 67 (view G). This leaves the assembly on sleeve 31 free to rotate, in a direction following the rotation of the knob 23, under the tensioned spring 51. Such action takes place substantially instantaneously. However, the assembly on sleeve 31 is permitted to rotate, not the full 180° , but only 90° , in the following manner: When the sleeve 31 has rotated, say, 5° less than 90° , the projection 63 on disc 61 comes into engagement with the cam end 93 of the upper arm 85 of lever 83 (view K). The engagement pushes the arm 85 upwardly, thus moving the lower arm 87 against the periphery of disc 53. When full 90° rotation is attained, then, the projection 55 on disc 53 meets the hook end 89 of arm 87, and the rotation of the assembly on sleeve 31 is thus stopped at 90° position (view O). The spring 51 is accordingly left with a 90° -more-than-initial tension.

Contemporaneously with the last-mentioned movements, the connector disc 33 rotates 90° , bringing the contacts 35 into connection with the terminals 29, thus completing the circuit (view S). This is called "on" position.

One 180° rotation of the knob 23 is rarely sufficient to wind the clockwork 115. Accordingly, it is frequently desirable to continue the rotation of knob 23, in steps of 180° , until the clockwork 115 is completely wound. The action for subse-

quent rotations of the knob 23, aside from winding the clockwork 115, is as follows:

As before, just short of 180° , the projection (now 45) on disc 43 cams against the detent 73, swinging it backwardly. However, at this stage of operation, the projection 81 on detent 73 engages projection 91 on lower arm 87 of lever 83, and, with the backward motion of detent 73, carries along the lower arm 87 in similar backward motion. Lever 97 is out of the way for this entire stage of operation, nothing having occurred to move it from its view G position (view H).

When full 180° rotation is reached, the detent 73 springs back against the periphery of disc 43 and, through engagement with ear 45, prevents reverse rotation under the influence of spring 51 (view D). In this stage of operation, the engagement of projections 81 and 91 has removed the hook end 89 of arm 87 from the periphery of disc 53, and the assembly on sleeve 31 is thus free to follow the rotation of disc 43 under the influence of spring 51. This it does, and rotates freely through about 175° , at which position projection 65 on disc 61 engages cam end 93 of arm 85 and rotates the lever 83 so that, when full 180° rotation is secured, the hook end 89 of lower arm 87 engages projection 57 on disc 53, and prevents further rotation of the assembly on sleeve 31 (views L and P). The connector disc 33 contemporaneously rotates through 180° and completes rotation in an "on" position (view T).

It will be seen that so far the disc 43 has travelled through 360° , while the assembly on sleeve 31 has only travelled through 270° . The spring 51 is thus left in a condition of 90° -greater-than-initial tension.

Subsequent rotations of the knob 23 through 180° intervals (any rotation less than 180° being ineffectual to do anything) in completing the winding of clockwork 115 occasion successive operations similar to the operation last described. In each case, the final position is with connector disc 33 in "on" position and the assembly on sleeve 31 lagging 90° behind the disc 43.

The time control is effected as follows:

With the switch in the condition last above mentioned, the time-knob 21 is manually rotated to the desired position, as determined by pointer 25 on scale 27. Such rotation carries the time disc 121 through a like rotation, and at the end the projection 123 is spaced the desired interval from projection 103 of lever 97 (view D).

Time now elapses, and the running clockwork 115 slowly rotates the projection 123 nearer and nearer to the projection 103 on lever 97. At the end of the desired time interval, the following changes take place:

The projection 123 on time disc 121 bears against projection 103 on lever 97, and rotates said lever to the left. In so doing, the pin 107 bears on the cam surface 95 of upper arm 85. Ultimately, as the lever 97 reaches such position that its projection 101 engages the periphery of disc 67, the lower arm 87 is moved so that the hook end 89 thereof is brought out of engagement with projection 57 on disc 53, thus leaving the assembly on sleeve 31 free to rotate. Rotation accordingly ensues, under the tension of spring 51 (which was, it will be remembered) tensioned 90° more than normal.

When the sleeve 31 and its assembly has rotated through 90° , projection 69 on disc 67 is stopped by projection 101 on lever 97, and thus the entire assembly is stopped. The condition of the switch is again normal (views A, E, I, M, and Q),

contacts are "off", and the spring 51 has returned to normal tension.

The clockwork 115 may continue to run, but suitable frictional clutches on its main shaft prevent the stoppage of disc 121 (through engagement of projections 123 and 103) from doing any harm.

For securing an "on" position only for a short length of time, no setting of knob 21 is necessary, inasmuch as, when the lever 97 is forced to the right (views E, F, and G) the projection 103 engaging the projection 123 effects an automatic setting of the time control for a short duration (see views A, B, and C, illustrating the automatic setting of disc 121).

This completes the description of the construction and operation of the preferred form of switch. Many modifications are obviously possible, but the following are particularly advantageous under certain operating conditions:

Fig. 7 is similar to view A of Fig. 6, but shows a form of switch in which the time control is utilized to effect a connected, or "on", circuit, after the desired time lapse. Such an effect is secured by mounting the connector disc 33 at a 90° position to its previously described position. In other respects the switch is the same. It is to be noted that in one switch an adjustable position connector disc may be provided, whereby the switch may be utilized as a time "on" or a time "off" switch with one simple adjustment.

Fig. 8 illustrates an alternative form of contactor disc, in which a drum 131 is provided, having a conducting segment 133 and a non-conducting segment 135 suitably arranged. Spring terminals 29 of the first embodiment are replaced by suitable brushes 137. The operation is the same as has been described heretofore.

In Figs. 9 and 10 is shown a modification in which a single disc 139 is made to perform the functions of heretofore-described discs 61 and 67. Accordingly, disc 139 is provided with four projections 141, 143, 145 and 147. The projection 101 on lever 97 is offset to work in the plane of disc 139, cooperating with projections 145 and 147 (which correspond to projections 69 and 71 on disc 67). Upper arm 85 of lever 83 cooperates with projections 141 and 143 (which correspond to projections 63 and 65 on disc 61). The construction and operation of the switch is otherwise as heretofore described.

In view of the above, it will be seen that the several objects of the invention are achieved and other advantageous results obtained.

As many changes could be made in carrying out the above constructions without departing from the scope of the invention, it is intended that all matter contained in the above description or shown in the accompanying drawings shall be interpreted as illustrative and not in a limiting sense.

I claim:

1. A time-controlled switch comprising a rotary contacting means, means for securing said contacting means normally in "off" position, manually operable means for rotating said contacting means, initially, the order of 90° to "on" position, and in successive steps thereafter, the order of 180° to "on" position, a clockwork mechanism, means associated with said clockwork mechanism for establishing a time interval, and means adapted, upon the expiration of said time interval, to cause said contacting means to rotate, from "on" position, the order of 90° to "off" position, said manually operable means comprising a series of

discs and escapement levers cooperating therewith, a separately rotatable shaft, and a tension spring connecting said shaft and said contacting means.

2. A time-controlled switch comprising a rotary contacting means and a rotary manual control means, resilient means connecting said contacting means and said control means effecting coextensive rotation thereof, and a plurality of escapement means, said escapement means functioning so that, upon manual rotation of said control means through a predetermined angle of rotation, said contacting means rotates coextensively therewith, but only through a part of said predetermined angle, and time-controlled means cooperating with said escapement means whereby, at the expiration of a predetermined time interval, said escapement means permit said contacting means to rotate the remainder of said predetermined angle.

3. A switch as in claim 2, in which said escapement means, upon initial rotation of said control means, automatically set said time-controlled means for a predetermined relatively short time interval.

4. A switch as in claim 2, in which said escapement means operate, after the first rotation of said control means through said predetermined angle, to permit further rotations of said control means through additional predetermined angles, upon which further rotation, said contacting means is permitted to rotate coextensively with said control means to the full extent of said additional predetermined angles.

5. A time-controlled switch comprising a rotary contacting means and a manually rotary knob, a spring connecting said knob and said contacting means effecting coextensive rotation thereof, means limiting effective rotation of said knob to successive angles of the order of 180° each, means operable upon the initial 180° rotation of said knob to limit rotation of said contacting means to the order of 90°, and time-controlled means operable at the expiration of a predetermined time interval, to permit said contacting means to rotate an additional 90° under the influence of said resilient means.

6. A time-controlled switch comprising a rotary contacting means and a manually rotary knob, a spring connecting said knob and said contacting means effecting coextensive rotation thereof, means limiting effective rotation of said knob to successive angles of the order of 180° each, means operable upon the initial 180° rotation of said knob to limit rotation of said contacting means to the order of 90°, said last-named means permitting additional completely coextensive rotations of said knob and said contacting means through intervals of the order of 180°, and time-controlled means operable at the expiration of a predetermined time interval, to permit said contacting means to rotate an additional 90° under the influence of said resilient means.

7. A time-controlled switch comprising a rotatable shaft, a manually operable knob fixed on said shaft, and a sleeve rotating on said shaft, a torsion spring connecting said knob and said sleeve, contacting means mounted on said sleeve, means associated with said knob limiting effective rotation thereof to successive angles of the order of 180°, said torsion spring causing said sleeve to tend to rotate with said knob, means associated with said sleeve limiting initial rotation thereof, under influence of said spring, to an angle of the order of 90°, and time-controlled means associated

with said last-named means operative at the expiration of a predetermined time interval to allow said sleeve to rotate an additional angle of the order of 90° under the influence of said spring.

5
10
15
20
25
30
35
40

8. A time-controlled switch comprising a rotatable shaft, a manually operable knob fixed on said shaft, and a sleeve rotating on said shaft, a torsion spring connecting said knob and said sleeve, contacting means mounted on said sleeve, means associated with said knob limiting effective rotation thereof to successive angles of the order of 180°, said torsion spring causing said sleeve to tend to rotate with said knob, means associated with said sleeve limiting initial rotation thereof, under influence of said spring, to an angle of the order of 90°, but permitting said sleeve to rotate with said knob in angles of 180°

after said initial rotation, and time-controlled means associated with said last-named means operative at the expiration of a predetermined time interval to allow said sleeve to rotate an additional angle of the order of 90° under the influence of said spring.

9. A switch as set forth in claim 8 including a pair of fixed terminals, said fixed terminals normally being spaced the order of 90° from said contacting means, but engaging said contacting means after said knob is rotated through initial and subsequent angles of 180°.

10. A switch as set forth in claim 8 including means operable automatically upon the initial rotation of said knob to set said time-controlled means for a predetermined, relatively short time interval.

RICHARD V. REPPERT.

80

85

90

95

100

105

110

115