

(19) World Intellectual Property Organization
International Bureau



(43) International Publication Date
14 October 2010 (14.10.2010)

(10) International Publication Number
WO 2010/117912 A1

(51) International Patent Classification:
G11C 7/18 (2006.01) *H01L 27/24* (2006.01)
G11C 13/00 (2006.01)

fornia 95120 (US). **FASOLI, Luca** [IT/US]; 523 De Carli Court, Campbell, California 95008 (US).

(21) International Application Number:
PCT/US2010/029855

(74) Agents: **YAU, Philip** et al.; Davis Wright Tremaine LLP, 505 Montgomery Street, Suite 800, San Francisco, California 94111 (US).

(22) International Filing Date:
2 April 2010 (02.04.2010)

(81) Designated States (unless otherwise indicated, for every kind of national protection available): AE, AG, AL, AM, AO, AT, AU, AZ, BA, BB, BG, BH, BR, BW, BY, BZ, CA, CH, CL, CN, CO, CR, CU, CZ, DE, DK, DM, DO, DZ, EC, EE, EG, ES, FI, GB, GD, GE, GH, GM, GT, HN, HR, HU, ID, IL, IN, IS, JP, KE, KG, KM, KN, KP, KR, KZ, LA, LC, LK, LR, LS, LT, LU, LY, MA, MD, ME, MG, MK, MN, MW, MX, MY, MZ, NA, NG, NI, NO, NZ, OM, PE, PG, PH, PL, PT, RO, RS, RU, SC, SD, SE, SG, SK, SL, SM, ST, SV, SY, TH, TJ, TM, TN, TR, TT, TZ, UA, UG, US, UZ, VC, VN, ZA, ZM, ZW.

(25) Filing Language: English

(26) Publication Language: English

(30) Priority Data:
12/420,334 8 April 2009 (08.04.2009) US
12/748,233 26 March 2010 (26.03.2010) US
12/748,260 26 March 2010 (26.03.2010) US

(71) Applicant (for all designated States except US): **SAN-DISK 3D LLC** [US/US]; 601 McCarthy Blvd., Milpitas, California 95035 (US).

(84) Designated States (unless otherwise indicated, for every kind of regional protection available): ARIPO (BW, GH, GM, KE, LR, LS, MW, MZ, NA, SD, SL, SZ, TZ, UG, ZM, ZW), Eurasian (AM, AZ, BY, KG, KZ, MD, RU, TJ, TM), European (AT, BE, BG, CH, CY, CZ, DE, DK, EE, ES, FI, FR, GB, GR, HR, HU, IE, IS, IT, LT, LU, LV,

(72) Inventors; and
(75) Inventors/Applicants (for US only): **SAMACHISA, George** [US/US]; 6858 Castlerock Drive, San Jose, Cali-

[Continued on next page]

(54) Title: THREE-DIMENSIONAL ARRAY OF RE-PROGRAMMABLE NON-VOLATILE MEMORY ELEMENTS HAVING VERTICAL BIT LINES AND A DOUBLE-GLOBAL-BIT-LINE ARCHITECTURE

(57) Abstract: A three-dimensional array especially adapted for memory elements that reversibly change a level of electrical conductance in response to a voltage difference being applied across them. Memory elements are formed across a plurality of planes positioned different distances above a semiconductor substrate. A two-dimensional array of bit lines to which the memory elements of all planes are connected is oriented vertically from the substrate and through the plurality of planes. A double-global-bit-line architecture provides a pair of global bit lines for each bit lines for accessing a row of memory elements in parallel. A first one of each pair allows the local bit lines of the row to be sensed while a second one of each pair allows local bit lines in an adjacent row to be set to a definite voltage so as to eliminate leakage currents between adjacent rows of local bit lines.

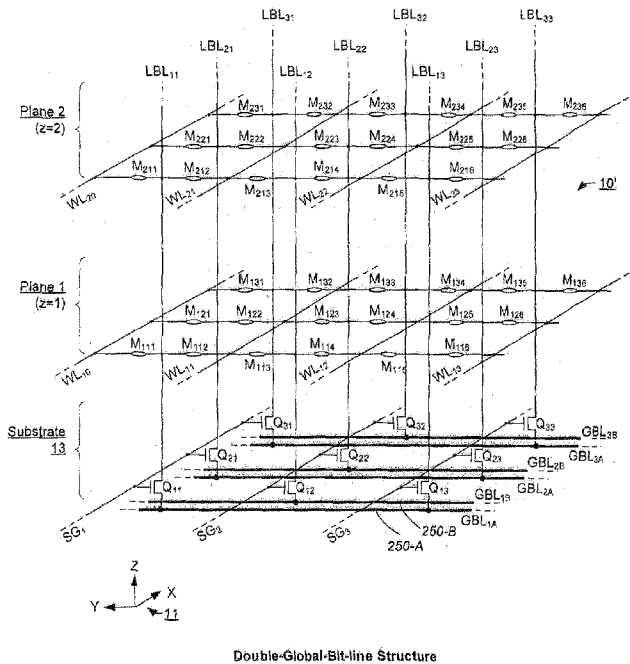

FIG. 17

WO 2010/117912 A1

MC, MK, MT, NL, NO, PL, PT, RO, SE, SI, SK, SM, **Published:**
TR), OAPI (BF, BJ, CF, CG, CI, CM, GA, GN, GQ, GW, — *with international search report (Art. 21(3))*
ML, MR, NE, SN, TD, TG).

THREE-DIMENSIONAL ARRAY OF RE-PROGRAMMABLE NON-VOLATILE MEMORY ELEMENTS HAVING VERTICAL BIT LINES AND A DOUBLE-GLOBAL-BIT-LINE ARCHITECTURE

BACKGROUND

[0001] The subject matter of this application is the structure, use and making of re-programmable non-volatile memory cell arrays, and, more specifically, to three-dimensional arrays of memory storage elements formed on semiconductor substrates.

[0002] Uses of re-programmable non-volatile mass data storage systems utilizing flash memory are widespread for storing data of computer files, camera pictures, and data generated by and/or used by other types of hosts. A popular form of flash memory is a card that is removably connected to the host through a connector. There are many different flash memory cards that are commercially available, examples being those sold under trademarks CompactFlash (CF), the MultiMediaCard (MMC), Secure Digital (SD), miniSD, microSD, Memory Stick, Memory Stick Micro, xD-Picture Card, SmartMedia and TransFlash. These cards have unique mechanical plugs and/or electrical interfaces according to their specifications, and plug into mating receptacles provided as part of or connected with the host.

[0003] Another form of flash memory systems in widespread use is the flash drive, which is a hand held memory system in a small elongated package that has a Universal Serial Bus (USB) plug for connecting with a host by plugging it into the host's USB receptacle. SanDisk Corporation, assignee hereof, sells flash drives under its Cruzer, Ultra and Extreme Contour trademarks. In yet another form of flash memory systems, a large amount of memory is permanently installed within host systems, such as within a notebook computer in place of the usual disk drive mass data storage system. Each of these three forms of mass data storage systems generally includes the same type of flash memory arrays. They each also usually contain its own memory controller and drivers but there are also some memory only systems that are instead controlled at least in part by software executed by the host to which the memory is connected. The flash memory is typically formed on one or more integrated circuit chips and the controller on another circuit chip. But in some

memory systems that include the controller, especially those embedded within a host, the memory, controller and drivers are often formed on a single integrated circuit chip.

[0004] There are two primary techniques by which data are communicated between the host and flash memory systems. In one of them, addresses of data files generated or received by the system are mapped into distinct ranges of a continuous logical address space established for the system. The extent of the address space is typically sufficient to cover the full range of addresses that the system is capable of handling. As one example, magnetic disk storage drives communicate with computers or other host systems through such a logical address space. The host system keeps track of the logical addresses assigned to its files by a file allocation table (FAT) and the memory system maintains a map of those logical addresses into physical memory addresses where the data are stored. Most memory cards and flash drives that are commercially available utilize this type of interface since it emulates that of magnetic disk drives with which hosts have commonly interfaced.

[0005] In the second of the two techniques, data files generated by an electronic system are uniquely identified and their data logically addressed by offsets within the file. These file identifiers are then directly mapped within the memory system into physical memory locations. Both types of host/memory system interfaces are described and contrasted elsewhere, such as in patent application publication no. US 2006/0184720 A1.

[0006] Flash memory systems typically utilize integrated circuits with arrays of memory cells that individually store an electrical charge that controls the threshold level of the memory cells according to the data being stored in them. Electrically conductive floating gates are most commonly provided as part of the memory cells to store the charge but dielectric charge trapping material is alternatively used. A NAND architecture is generally preferred for the memory cell arrays used for large capacity mass storage systems. Other architectures, such as NOR, are typically used instead for small capacity memories. Examples of NAND flash arrays and their operation as part of flash memory systems may be had by reference to United States patents nos. 5,570,315, 5,774,397, 6,046,935, 6,373,746, 6,456,528, 6,522,580, 6,643,188, 6,771,536, 6,781,877 and 7,342,279.

[0007] The amount of integrated circuit area necessary for each bit of data stored in the memory cell array has been reduced significantly over the years, and the goal remains to reduce this further. The cost and size of the flash memory systems are therefore being reduced as a result. The use of the NAND array architecture contributes to this but other approaches have also been employed to reducing the size of memory cell arrays. One of these other approaches is to form, on a semiconductor substrate, multiple two-dimensional memory cell arrays, one on top of another in different planes, instead of the more typical single array. Examples of integrated circuits having multiple stacked NAND flash memory cell array planes are given in United States patents nos. 7,023,739 and 7,177,191.

[0008] Another type of re-programmable non-volatile memory cell uses variable resistance memory elements that may be set to either conductive or non-conductive states (or, alternately, low or high resistance states, respectively), and some additionally to partially conductive states and remain in that state until subsequently re-set to the initial condition. The variable resistance elements are individually connected between two orthogonally extending conductors (typically bit and word lines) where they cross each other in a two-dimensional array. The state of such an element is typically changed by proper voltages being placed on the intersecting conductors. Since these voltages are necessarily also applied to a large number of other unselected resistive elements because they are connected along the same conductors as the states of selected elements being programmed or read, diodes are commonly connected in series with the variable resistive elements in order to reduce leakage currents that can flow through them. The desire to perform data reading and programming operations with a large number of memory cells in parallel results in reading or programming voltages being applied to a very large number of other memory cells. An example of an array of variable resistive memory elements and associated diodes is given in patent application publication no. US 2009/0001344 A1.

SUMMARY OF THE INVENTION

[0009] The present application is directed to a three-dimensional array of memory elements wherein bit lines of the array are oriented vertically. That is,

instead of merely stacking a plurality of existing two-dimensional arrays on a common semiconductor substrate, where each two-dimensional array has its own bit lines, multiple two-dimensional arrays without bit lines are stacked on top of each other in separate planes but then share common bit lines that extend up through the planes. These bit lines are those whose voltages or currents depend on the data being read from or programmed into the memory.

[0010] The memory elements used in the three-dimensional array are preferably variable resistive memory elements. That is, the resistance (and thus inversely the conductance) of the individual memory elements is typically changed as a result of a voltage placed across the orthogonally intersecting conductors to which the element is connected. Depending on the type of variable resistive element, the state may change in response to a voltage across it, a level of current through it, an amount of electric field across it, a level of heat applied to it, and the like. With some variable resistive element material, it is the amount of time that the voltage, current, electric field, heat and the like is applied to the element that determines when its conductive state changes and the direction in which the change takes place. In between such state changing operations, the resistance of the memory element remains unchanged, so is non-volatile. The three-dimensional array architecture summarized above may be implemented with a memory element material selected from a wide variety of such materials having different properties and operating characteristics.

[0011] The resistance of the memory element, and thus its detectable storage state, can be repetitively set from an initial level to another level and then re-set back to the initial level. For some materials, the amount or duration of the voltage, current, electric field, heat and the like applied to change its state in one direction is different (asymmetrical) with that applied to change in another direction. With two detectable states, each memory element stores one-bit of data. With the use of some materials, more than one bit of data may be stored in each memory element by designating more than two stable levels of resistance as detectable states of the memory element. The three-dimensional array architecture herein is quite versatile in the way it may be operated.

[0012] This three-dimensional architecture also allows limiting the extent and number of unaddressed (non-selected) resistive memory elements across which an undesired level of voltage is applied during reading and programming operations conducted on other addressed (selected) memory elements. The risk of disturbing the states of unaddressed memory elements and the levels of leakage current passing through unaddressed elements may be significantly reduced from those experienced in other arrays using the same memory element material. Leakage currents are undesirable because they can alter the apparent currents being read from addressed memory elements, thereby making it difficult to accurately read the states of addressed (selected) memory elements. Leakage currents are also undesirable because they add to the overall power draw by an array and therefore undesirably causes the power supply to have to be made larger than is desirable. Because of the relatively small extent of unaddressed memory elements that have voltages applied during programming and reading of addressed memory elements, the array with the three-dimensional architecture herein may be made to include a much larger number of memory elements without introducing errors in reading and exceeding reasonable power supply capabilities.

[0013] In addition, the three-dimensional architecture herein allows variable resistance memory elements to be connected at preferably orthogonal crossings of bit and word line conductors without the need for diodes or other non-linear elements being connected in series with the variable resistive elements. In existing arrays of variable resistance memory elements, a diode is commonly connected in series with each memory element in order to reduce the leakage current through the element when it is unselected but nevertheless has a voltage difference placed across it, such as can occur when the unselected memory element is connected to a bit or word line carrying voltages to selected memory elements connected to those same lines. The absence of the need for diodes significantly reduces the complexity of the array and thus the number of processing steps required to manufacture it.

[0014] Indeed, the manufacture of the three-dimensional array of memory elements herein is much simpler than other three-dimensional arrays using the same type of memory elements. In particular, a fewer number of masks is required to form the elements of each plane of the array. The total number of processing steps needed

to form integrated circuits with the three-dimensional array is thus reduced, as is the cost of the resulting integrated circuit.

DOUBLE-GLOBAL-BIT-LINE ARCHITECTURE

[0015] According to one aspect of the invention, a 3D memory includes memory elements arranged in a three-dimensional pattern defined by rectangular coordinates having x, y and z-directions and with a plurality of parallel planes stacked in the z-direction. The memory elements in each plane are accessed by a plurality of word lines and local bit lines in tandem with a plurality of global bit lines. The plurality of local bit lines are in the z-direction through the plurality of planes and arranged in a two dimensional rectangular array of rows in the x-direction and columns in the y-directions. The plurality of word lines in each plane are elongated in the x-direction and spaced apart in the y-direction between and separated from the plurality of local bit lines in the individual planes. A non-volatile, reprogramming memory element is located near a crossing between a word line and local bit line and accessible by the word line and bit line and wherein a group of memory elements are accessible in parallel by a common word line and a row of local bit lines. The 3D memory further includes a double-global-bit line architecture with two global bit lines respectively serving even and odd local bit lines in a column thereof in the y-direction. This architecture allows one global bit line to be used by a sense amplifier to access a selected local bit line and the other global bit line to be used to access unselected local bit lines adjacent the selected local bit line in the y-direction. In this way the adjacent, unselected local lines can be set to exactly a reference voltage same as that of the selected local bit line in order to eliminate leakage currents between adjacent bit lines.

SINGLE-SIDED WORD LINE ARCHITECTURE

[0016] According to another embodiment of the invention, a 3D memory includes memory elements arranged in a three-dimensional pattern defined by rectangular coordinates having x, y and z-directions and with a plurality of parallel planes stacked in the z-direction. The memory elements in each plane are accessed by a plurality of word lines and local bit lines in tandem with a plurality of global bit

lines. The plurality of local bit lines are in the z-direction through the plurality of planes and arranged in a two dimensional rectangular array of rows in the x-direction and columns in the y-directions. The plurality of word lines in each plane are elongated in the x-direction and spaced apart in the y-direction between and separated from the plurality of local bit lines in the individual planes. A non-volatile, reprogramming memory element is located near a crossing between a word line and local bit line and accessible by the word line and bit line and wherein a group of memory elements are accessible in parallel by a common word line and a row of local bit lines. The 3D memory has a single-sided word line architecture with each word line exclusively connected to one row of memory elements. This is accomplished by providing one word line for each row of memory elements instead of sharing one word line between two rows of memory elements and linking the memory element across the array across the word lines. A single-sided word line architecture provides a word line exclusively for each row of memory elements instead of sharing one word line between two rows of memory elements thereby avoids linking the memory element across the array across the word lines. While the row of memory elements is also being accessed by a corresponding row of local bit lines, there is no extension of coupling between adjacent rows of local bit lines and therefore leakage currents beyond the word line.

[0017] The single-sided word line architecture has the advantage of decoupling local bit-line to local bit line coupling across the plurality of word lines in the y-direction. Thus, leakage currents between local bit lines are eliminated.

[0018] Various aspects, advantages, features and details of the innovative three-dimensional variable resistive element memory system are included in a description of exemplary examples thereof that follows, which description should be taken in conjunction with the accompanying drawings.

[0019] All patents, patent applications, articles, other publications, documents and things referenced herein are hereby incorporated herein by this reference in their entirety for all purposes. To the extent of any inconsistency or conflict in the definition or use of terms between any of the incorporated publications, documents or things and the present application, those of the present application shall prevail.

BRIEF DESCRIPTION OF THE DRAWINGS

- [0020] **FIG. 1** is an equivalent circuit of a portion of a three-dimensional array of variable resistance memory elements, wherein the array has vertical bit lines;
- [0021] **FIG. 2** is a schematic block diagram of a re-programmable non-volatile memory system which utilizes the memory cell array of **FIG. 1**, and which indicates connection of the memory system with a host system;
- [0022] **FIG. 3** provides plan views of the two planes and substrate of the three-dimensional array of **FIG. 1**, with some structure added;
- [0023] **FIG. 4** is an expanded view of a portion of one of the planes of **FIG. 3**, annotated to show effects of programming data therein;
- [0024] **FIG. 5** is an expanded view of a portion of one of the planes of **FIG. 3**, annotated to show effects of reading data therefrom;
- [0025] **FIG. 6** illustrates an example memory storage element;
- [0026] **FIG. 7** is an isometric view of a portion of the three-dimensional array shown in **FIG. 1** according to a first specific example of an implementation thereof;
- [0027] **FIG. 8** is cross-section of a portion of the three-dimensional array shown in **FIG. 1** according to a second specific example of an implementation thereof;
- [0028] **FIGS. 9-14** illustrate a process of forming the three-dimensional array example of **FIG. 8**; and
- [0029] **FIG. 15** is a cross-section of a portion of the three-dimensional array shown in **FIG. 1** according to a third specific example of an implementation thereof.
- [0030] **FIG. 16** illustrates the read bias voltages and current leakage across multiple planes of the 3D memory shown in **FIG. 1** and **FIG. 3**.
- [0031] **FIG. 17** illustrates a three-dimensional memory with a double-global-bit-line architecture for improved access to a set of local bit lines.
- [0032] **FIG. 18** illustrates the elimination of leakage currents in the double-global-line architecture 3D array of **FIG. 17**.
- [0033] **FIG. 19** illustrates schematically a single-sided word line architecture.

[0034] FIG. 20 illustrates one plane and substrate of the 3D array with the single-sided word line architecture.

[0035] FIG. 21 illustrates the elimination of leakage currents in the single-sided word-line architecture 3-D array of FIG. 19 and 20.

[0036] FIG. 22 is an isometric view of a portion of the 3D array with the single-sided word line architecture shown in FIG. 19.

DESCRIPTION OF EXEMPLARY EMBODIMENTS

[0037] Referring initially to FIG. 1, an architecture of a three-dimensional memory 10 is schematically and generally illustrated in the form of an equivalent circuit of a portion of such a memory. This is a specific example of the three-dimensional array summarized above. A standard three-dimensional rectangular coordinate system 11 is used for reference, the directions of each of vectors x, y and z being orthogonal with the other two.

[0038] A circuit for selectively connecting internal memory elements with external data circuits is preferably formed in a semiconductor substrate 13. In this specific example, a two-dimensional array of select or switching devices Q_{xy} are utilized, where x gives a relative position of the device in the x-direction and y its relative position in the y-direction. The individual devices Q_{xy} may be a select gate or select transistor, as examples. Global bit lines (GBL_x) are elongated in the y-direction and have relative positions in the x-direction that are indicated by the subscript. The global bit lines (GBL_x) are individually connectable with the source or drain of the select devices Q having the same position in the x-direction, although during reading and also typically programming only one select device connected with a specific global bit line is turned on at time. The other of the source or drain of the individual select devices Q is connected with one of the local bit lines (LBL_{xy}). The local bit lines are elongated vertically, in the z-direction, and form a regular two-dimensional array in the x (row) and y (column) directions.

[0039] In order to connect one set (in this example, designated as one row) of local bit lines with corresponding global bit lines, control gate lines SG_y are elongated

in the x-direction and connect with control terminals (gates) of a single row of select devices Q_{xy} having a common position in the y-direction. The select devices Q_{xy} therefore connect one row of local bit lines (LBL_{xy}) across the x-direction (having the same position in the y-direction) at a time to corresponding ones of the global bit-lines (GBL_x), depending upon which of the control gate lines SG_y receives a voltage that turns on the select devices to which it is connected. The remaining control gate lines receive voltages that keep their connected select devices off. It may be noted that since only one select device (Q_{xy}) is used with each of the local bit lines (LBL_{xy}), the pitch of the array across the semiconductor substrate in both x and y-directions may be made very small, and thus the density of the memory storage elements large.

[0040] Memory storage elements M_{zxy} are formed in a plurality of planes positioned at different distances in the z-direction above the substrate 13. Two planes 1 and 2 are illustrated in **FIG. 1** but there will typically be more, such as 4, 6 or even more. In each plane at distance z, word lines WL_{zy} are elongated in the x-direction and spaced apart in the y-direction between the local bit-lines (LBL_{xy}). The word lines WL_{zy} of each plane individually cross adjacent two of the local bit-lines LBL_{xy} on either side of the word lines. The individual memory storage elements M_{zxy} are connected between one local bit line LBL_{xy} and one word line WL_{zy} adjacent these individual crossings. An individual memory element M_{zxy} is therefore addressable by placing proper voltages on the local bit line LBL_{xy} and word line WL_{zy} between which the memory element is connected. The voltages are chosen to provide the electrical stimulus necessary to cause the state of the memory element to change from an existing state to the desired new state. The levels, duration and other characteristics of these voltages depend upon the material that is used for the memory elements.

[0041] Each “plane” of the three-dimensional memory cell structure is typically formed of at least two layers, one in which the conductive word lines WL_{zy} are positioned and another of a dielectric material that electrically isolates the planes from each other. Additional layers may also be present in each plane, depending for example on the structure of the memory elements M_{zxy} . The planes are stacked on

top of each other on a semiconductor substrate with the local bit lines LBL_{xy} being connected with storage elements M_{zxy} of each plane through which the local bit lines extend.

[0042] **FIG. 2** is a block diagram of an illustrative memory system that can use the three-dimensional memory 10 of **FIG. 1**. Data input-output circuits 21 are connected to provide (during programming) and receive (during reading) analog electrical quantities in parallel over the global bit-lines GBL_x of **FIG. 1** that are representative of data stored in addressed storage elements M_{zxy} . The circuits 21 typically contain sense amplifiers for converting these electrical quantities into digital data values during reading, which digital values are then conveyed over lines 23 to a memory system controller 25. Conversely, data to be programmed into the array 10 are sent by the controller 25 to the input-output circuits 21, which then programs that data into addressed memory element by placing proper voltages on the global bit lines GBL_x . For binary operation, one voltage level is typically placed on a global bit line to represent a binary "1" and another voltage level to represent a binary "0". The memory elements are addressed for reading or programming by voltages placed on the word lines WL_{zy} and select gate control lines SG_y by respective word line select circuits 27 and local bit line circuits 29. In the specific three-dimensional array of **FIG. 1**, the memory elements lying between a selected word line and any of the local bit lines LBL_{xy} connected at one instance through the select devices Q_{xy} to the global bit lines GBL_x may be addressed for programming or reading by appropriate voltages being applied through the select circuits 27 and 29.

[0043] The memory system controller 25 typically receives data from and sends data to a host system 31. The controller 25 usually contains an amount of random-access-memory (RAM) 34 for temporarily storing such data and operating information. Commands, status signals and addresses of data being read or programmed are also exchanged between the controller 25 and host 31. The memory system operates with a wide variety of host systems. They include personal computers (PCs), laptop and other portable computers, cellular telephones, personal digital assistants (PDAs), digital still cameras, digital movie cameras and portable audio players. The host typically includes a built-in receptacle 33 for one or more

types of memory cards or flash drives that accepts a mating memory system plug 35 of the memory system but some hosts require the use of adapters into which a memory card is plugged, and others require the use of cables therebetween. Alternatively, the memory system may be built into the host system as an integral part thereof.

[0044] The memory system controller 25 conveys to decoder/driver circuits 37 commands received from the host. Similarly, status signals generated by the memory system are communicated to the controller 25 from the circuits 37. The circuits 37 can be simple logic circuits in the case where the controller controls nearly all of the memory operations, or can include a state machine to control at least some of the repetitive memory operations necessary to carry out given commands. Control signals resulting from decoding commands are applied from the circuits 37 to the word line select circuits 27, local bit line select circuits 29 and data input-output circuits 21. Also connected to the circuits 27 and 29 are address lines 39 from the controller that carry physical addresses of memory elements to be accessed within the array 10 in order to carry out a command from the host. The physical addresses correspond to logical addresses received from the host system 31, the conversion being made by the controller 25 and/or the decoder/driver 37. As a result, the circuits 29 partially address the designated storage elements within the array 10 by placing proper voltages on the control elements of the select devices Q_{xy} to connect selected local bit lines (LBL_{xy}) with the global bit lines (GBL_x). The addressing is completed by the circuits 27 applying proper voltages to the word lines WL_{zy} of the array.

[0045] Although the memory system of **FIG. 2** utilizes the three-dimensional memory element array 10 of **FIG. 1**, the system is not limited to use of only that array architecture. A given memory system may alternatively combine this type of memory with other another type including flash memory, such as flash having a NAND memory cell array architecture, a magnetic disk drive or some other type of memory. The other type of memory may have its own controller or may in some cases share the controller 25 with the three-dimensional memory cell array 10, particularly if there is some compatibility between the two types of memory at an operational level.

[0046] Although each of the memory elements M_{zxy} in the array of **FIG. 1** may be individually addressed for changing its state according to incoming data or for

reading its existing storage state, it is certainly preferable to program and read the array in units of multiple memory elements in parallel. In the three-dimensional array of **FIG. 1**, one row of memory elements on one plane may be programmed and read in parallel. The number of memory elements operated in parallel depends on the number of memory elements connected to the selected word line. In some arrays, the word lines may be segmented (not shown in **FIG. 1**) so that only a portion of the total number of memory elements connected along their length may be addressed for parallel operation, namely the memory elements connected to a selected one of the segments.

[0047] Previously programmed memory elements whose data have become obsolete may be addressed and re-programmed from the states in which they were previously programmed. The states of the memory elements being re-programmed in parallel will therefore most often have different starting states among them. This is acceptable for many memory element materials but it is usually preferred to re-set a group of memory elements to a common state before they are re-programmed. For this purpose, the memory elements may be grouped into blocks, where the memory elements of each block are simultaneously reset to a common state, preferably one of the programmed states, in preparation for subsequently programming them. If the memory element material being used is characterized by changing from a first to a second state in significantly less time than it takes to be changed from the second state back to the first state, then the reset operation is preferably chosen to cause the transition taking the longer time to be made. The programming is then done faster than resetting. The longer reset time is usually not a problem since resetting blocks of memory elements containing nothing but obsolete data is typically accomplished in a high percentage of the cases in the background, therefore not adversely impacting the programming performance of the memory system.

[0048] With the use of block re-setting of memory elements, a three-dimensional array of variable resistive memory elements may be operated in a manner similar to current flash memory cell arrays. Resetting a block of memory elements to a common state corresponds to erasing a block of flash memory cells to an erased state. The individual blocks of memory elements herein may be further divided into a plurality of pages of storage elements, wherein the memory elements of a page are

programmed and read together. This is like the use of pages in flash memories. The memory elements of an individual page are programmed and read together. Of course, when programming, those memory elements that are to store data that are represented by the reset state are not changed from the reset state. Those of the memory elements of a page that need to be changed to another state in order to represent the data being stored in them have their states changed by the programming operation.

[0049] An example of use of such blocks and pages is illustrated in **FIG. 3**, which provides plan schematic views of planes 1 and 2 of the array of **FIG. 1**. The different word lines WL_{zy} that extend across each of the planes and the local bit lines LBL_{xy} that extend through the planes are shown in two-dimensions. Individual blocks are made up of memory elements connected to both sides of one word line, or one segment of a word line if the word lines are segmented, in a single one of the planes. There are therefore a very large number of such blocks in each plane of the array. In the block illustrated in **FIG. 3**, each of the memory elements M_{114} , M_{124} , M_{134} , M_{115} , M_{125} and M_{135} connected to both sides of one word line WL_{12} form the block. Of course, there will be many more memory elements connected along the length of a word line but only a few of them are illustrated, for simplicity. The memory elements of each block are connected between the single word line and different ones of the local bit lines, namely, for the block illustrated in **FIG. 3**, between the word line WL_{12} and respective local bit lines LBL_{12} , LBL_{22} , LBL_{32} , LBL_{13} , LBL_{23} and LBL_{33} .

[0050] A page is also illustrated in **FIG. 3**. In the specific embodiment being described, there are two pages per block. One page is formed by the memory elements along one side of the word line of the block and the other page by the memory elements along the opposite side of the word line. The example page marked in **FIG. 3** is formed by memory elements M_{114} , M_{124} and M_{134} . Of course, a page will typically have a very large number of memory elements in order to be able to program and read a large amount of data at one time. Only a few of the storage elements of the page of **FIG. 3** are included, for simplicity in explanation.

[0051] Example resetting, programming and reading operations of the memory array of **FIGs. 1** and **3**, when operated as array 10 in the memory system of

FIG. 2, will now be described. For these examples, each of the memory elements M_{zxy} is taken to include a non-volatile memory material that can be switched between two stable states of different resistance levels by impressing voltages (or currents) of different polarity across the memory element, or voltages of the same polarity but different magnitudes and/or duration. For example, one class of material may be placed into a high resistance state by passing current in one direction through the element, and into a low resistance state by passing current in the other direction through the element. Or, in the case of switching using the same voltage polarity, one element may need a higher voltage and a shorter time to switch to a high resistance state and a lower voltage and a longer time to switch to a lower resistance state. These are the two memory states of the individual memory elements that indicate storage of one bit of data, which is either a "0" or a "1", depending upon the memory element state.

[0052] To reset (erase) a block of memory elements, the memory elements in that block are placed into their high resistance state. This state will be designated as the logical data state "1", following the convention used in current flash memory arrays but it could alternatively be designated to be a "0". As shown by the example in **FIG. 3**, a block includes all the memory elements that are electrically connected to one word line WL or segment thereof. A block is the smallest unit of memory elements in the array that are reset together. It can include thousands of memory elements. If a row of memory elements on one side of a word line includes 1000 of them, for example, a block will have 2000 memory elements from the two rows on either side of the word line.

[0053] The following steps may be taken to reset all the memory elements of a block, using the block illustrated in **FIG. 3** as an example:

1. Set all of the global bit lines (GBL_1 , GBL_2 and GBL_3 in the array of **FIGs. 1** and **3**) to zero volts, by the circuits 21 of **FIG. 2**.
2. Set at least the two select gate lines on either side of the one word line of the block to H' volts, so that the local bit lines on each side of the word line in the y-direction are connected to their respective global bit lines through their select devices and therefore brought to zero volts. The voltage H' is made high enough to turn on the select devices Q_{xy} , like something in a range

of 1-3 volts, typically 2 volts. The block shown in **FIG. 3** includes the word line WL_{12} , so the select gate lines SG_2 and SG_3 (**FIG. 1**) on either side of that word line are set to H' volts, by the circuits 29 of **FIG. 2**, in order to turn on the select devices Q_{12} , Q_{22} , Q_{32} , Q_{13} , Q_{23} and Q_{33} . This causes each of the local bit lines LBL_{12} , LBL_{22} , LBL_{32} , LBL_{13} , LBL_{23} and LBL_{33} in two adjacent rows extending in the x-direction to be connected to respective ones of the global bit lines $GBL1$, $GBL2$ and $GBL3$. Two of the local bit lines adjacent to each other in the y-direction are connected to a single global bit line. Those local bit lines are then set to the zero volts of the global bit lines. The remaining local bit lines preferably remain unconnected and with their voltages floating.

3. Set the word line of the block being reset to H volts. This reset voltage value is dependent on the switching material in the memory element and can be between a fraction of a volt to a few volts. All other word lines of the array, including the other word lines of selected plane 1 and all the word lines on the other unselected planes, are set to zero volts. In the array of **FIGs. 1** and **3**, word line WL_{12} is placed at H volts, while all other word lines in the array are placed at zero volts, all by the circuits 27 of **FIG. 2**.

[0054] The result is that H volts are placed across each of the memory elements of the block. In the example block of **FIG. 3**, this includes the memory elements M_{114} , M_{124} , M_{134} , M_{115} , M_{125} and M_{135} . For the type of memory material being used as an example, the resulting currents through these memory elements places any of them not already in a high resistance state, into that re-set state.

[0055] It may be noted that no stray currents will flow because only one word line has a non-zero voltage. The voltage on the one word line of the block can cause current to flow to ground only through the memory elements of the block. There is also nothing that can drive any of the unselected and electrically floating local bit lines to H volts, so no voltage difference will exist across any other memory elements of the array outside of the block. Therefore no voltages are applied across unselected memory elements in other blocks that can cause them to be inadvertently disturbed or reset.

[0056] It may also be noted that multiple blocks may be concurrently reset by setting any combination of word lines and the adjacent select gates to H or H' respectively. In this case, the only penalty for doing so is an increase in the amount of current that is required to simultaneously reset an increased number of memory elements. This affects the size of the power supply that is required.

[0057] The memory elements of a page are preferably programmed concurrently, in order to increase the parallelism of the memory system operation. An expanded version of the page indicated in **FIG. 3** is provided in **FIG. 4**, with annotations added to illustrate a programming operation. The individual memory elements of the page are initially in their reset state because all the memory elements of its block have previously been reset. The reset state is taken herein to represent a logical data "1". For any of these memory elements to store a logical data "0" in accordance with incoming data being programmed into the page, those memory elements are switched into their low resistance state, their set state, while the remaining memory elements of the page remain in the reset state.

[0058] For programming a page, only one row of select devices is turned on, resulting in only one row of local bit lines being connected to the global bit lines. This connection alternatively allows the memory elements of both pages of the block to be programmed in two sequential programming cycles, which then makes the number of memory elements in the reset and programming units equal.

[0059] Referring to **FIGs. 3** and **4**, an example programming operation within the indicated one page of memory elements M_{114} , M_{124} and M_{134} is described, as follows:

1. The voltages placed on the global bit lines are in accordance with the pattern of data received by the memory system for programming. In the example of **FIG. 4**, GBL_1 carries logical data bit "1", GBL_2 the logical bit "0" and GBL_3 the logical bit "1." The bit lines are set respectively to corresponding voltages M, H and M, as shown, where the M level voltage is high but not sufficient to program a memory element and the H level is high enough to force a memory element into the programmed state. The M level voltage may be about one-half of the H level voltage, between zero volts and

H. For example, a M level can be 0.7 volt, and a H level can be 1.5 volt. The H level used for programming is not necessary the same as the H level used for resetting or reading. In this case, according to the received data, memory elements M_{114} and M_{134} are to remain in their reset state, while memory element M_{124} is being programmed. Therefore, the programming voltages are applied only to memory element M_{124} of this page by the following steps.

2. Set the word line of the page being programmed to 0 volts, in this case selected word line WL_{12} . This is the only word line to which the memory elements of the page are connected. Each of the other word lines on all planes is set to the M level. These word line voltages are applied by the circuits 27 of **FIG. 2**.

3. Set one of the select gate lines below and on either side of the selected word line to the H' voltage level, in order to select a page for programming. For the page indicated in **FIGs. 3 and 4**, the H' voltage is placed on select gate line SG_2 in order to turn on select devices Q_{12} , Q_{22} and Q_{32} (**FIG. 1**). All other select gate lines, namely lines SG_1 and SG_3 in this example, are set to 0 volts in order to keep their select devices off. The select gate line voltages are applied by the circuits 29 of **FIG. 2**. This connects one row of local bit lines to the global bit lines and leaves all other local bit lines floating. In this example, the row of local bit lines LBL_{12} , LBL_{22} and LBL_{32} are connected to the respective global bit lines GBL_1 , GBL_2 and GBL_3 through the select devices that are turned on, while all other local bit lines (LBLs) of the array are left floating.

[0060] The result of this operation, for the example memory element material mentioned above, is that a programming current I_{PROG} is sent through the memory element M_{124} , thereby causing that memory element to change from a reset to a set (programmed) state. The same will occur with other memory elements (not shown) that are connected between the selected word line WL_{12} and a local bit line (LBL) that has the programming voltage level H applied.

[0061] An example of the relative timing of applying the above-listed programming voltages is to initially set all the global bit lines (GBLs), the selected

select gate line (SG), the selected word line and two adjacent word lines on either side of the selected word line on the one page all to the voltage level M. After this, selected ones of the GBLs are raised to the voltage level H according to the data being programmed while simultaneously dropping the voltage of the selected word line to 0 volts for the duration of the programming cycle. The word lines in plane 1 other than the selected word line WL_{12} and all word lines in the unselected other planes can be weakly driven to M, some lower voltage or allowed to float in order to reduce power that must be delivered by word line drivers that are part of the circuits 27 of **FIG. 2**.

[0062] By floating all the local bit lines other than the selected row (in this example, all but LBL_{12} , LBL_{22} and LBL_{32}), voltages can be loosely coupled to outer word lines of the selected plane 1 and word lines of other planes that are allowed to float through memory elements in their low resistance state (programmed) that are connected between the floating local bit lines and adjacent word lines. These outer word lines of the selected plane and word lines in unselected planes, although allowed to float, may eventually be driven up to voltage level M through a combination of programmed memory elements.

[0063] There are typically parasitic currents present during the programming operation that can increase the currents that must be supplied through the selected word line and global bit lines. During programming there are two sources of parasitic currents, one to the adjacent page in a different block and another to the adjacent page in the same block. An example of the first is the parasitic current I_{p1} shown on **FIG. 4** from the local bit line LBL_{22} that has been raised to the voltage level H during programming. The memory element M_{123} is connected between that voltage and the voltage level M on its word line WL_{11} . This voltage difference can cause the parasitic current $-I_{p1}$ to flow. Since there is no such voltage difference between the local bit lines LBL_{12} or LBL_{32} and the word line WL_{11} , no such parasitic current flows through either of the memory elements M_{113} or M_{133} , a result of these memory elements remaining in the reset state according to the data being programmed.

[0064] Other parasitic currents can similarly flow from the same local bit line LBL_{22} to an adjacent word line in other planes. The presence of these currents may

limit the number of planes that can be included in the memory system since the total current may increase with the number of planes. The limitation for programming is in the current capacity of the memory power supply, so the maximum number of planes is a tradeoff between the size of the power supply and the number of planes. A number of 4-8 planes may generally be used in most cases.

[0065] The other source of parasitic currents during programming is to an adjacent page in the same block. The local bit lines that are left floating (all but those connected to the row of memory elements being programmed) will tend to be driven to the voltage level M of unselected word lines through any programmed memory element on any plane. This in turn can cause parasitic currents to flow in the selected plane from these local bit lines at the M voltage level to the selected word line that is at zero volts. An example of this is given by the currents I_{P2} , I_{P3} and I_{P4} shown in **FIG. 4**. In general, these currents will be much less than the other parasitic current I_{P1} discussed above, since these currents flow only through those memory elements in their conductive state that are adjacent to the selected word line in the selected plane.

[0066] The above-described programming techniques ensure that the selected page is programmed (local bit lines at H , selected word line at 0) and that adjacent unselected word lines are at M . As mentioned earlier, other unselected word lines can be weakly driven to M or initially driven to M and then left floating. Alternately, word lines in any plane distant from the selected word line (for example, more than 5 word lines away) can also be left uncharged (at ground) or floating because the parasitic currents flowing to them are so low as to be negligible compared to the identified parasitic currents since they must flow through a series combination of five or more ON devices (devices in their low resistance state). This can reduce the power dissipation caused by charging a large number of word lines.

[0067] While the above description assumes that each memory element of the page being programmed will reach its desired ON value with one application of a programming pulse, a program-verify technique commonly used in NOR or NAND flash memory technology may alternately be used. In this process, a complete programming operation for a given page includes of a series of individual programming operations in which a smaller change in ON resistance occurs within each program operation. Interspersed between each program operation is a verify

(read) operation that determines whether an individual memory element has reached its desired programmed level of resistance or conductance consistent with the data being programmed in the memory element. The sequence of program/verify is terminated for each memory element as it is verified to reach the desired value of resistance or conductance. After all of memory elements being programmed are verified to have reached their desired programmed value, programming of the page of memory elements is then completed. An example of this technique is described in United States patent no. 5,172,338.

[0068] With reference primarily to **FIG. 5**, the parallel reading of the states of a page of memory elements, such as the memory elements M_{114} , M_{124} and M_{134} , is described. The steps of an example reading process are as follows:

1. Set all the global bit lines GBLs and all the word lines WL to a voltage V_R . The voltage V_R is simply a convenient reference voltage and can be any number of values but will typically be between 0 and 1 volt. In general, for operating modes where repeated reads occur, it is convenient to set all word lines in the array to V_R in order to reduce parasitic read currents, even though this requires charging all the word lines. However, as an alternative, it is only necessary to raise the selected word line (WL_{12} in **FIG. 5**), the word line in each of the other planes that is in the same position as the selected word line and the immediately adjacent word lines in all planes to V_R .
2. Turn on one row of select devices by placing a voltage on the control line adjacent to the selected word line in order to define the page to be read. In the example of **FIGs. 1** and **5**, a voltage is applied to the control line SG_2 in order to turn on the select devices Q_{12} , Q_{22} and Q_{32} . This connects one row of local bit lines LBL_{12} , LBL_{22} and LBL_{32} to their respective global bit lines GBL_1 , GBL_2 and GBL_3 . These local bit lines are then connected to individual sense amplifiers (SA) that are present in the circuits 21 of **FIG. 2**, and assume the potential V_R of the global bit lines to which they are connected. All other local bit lines LBLs are allowed to float.

3. Set the selected word line (WL_{12}) to a voltage of $V_R \pm V_{sense}$. The sign of V_{sense} is chosen based on the sense amplifier and has a magnitude of about 0.5 volt. The voltages on all other word lines remain the same.
4. Sense current flowing into ($V_R + V_{sense}$) or out of ($V_R - V_{sense}$) each sense amplifier for time T . These are the currents I_{R1} , I_{R2} and I_{R3} shown to be flowing through the addressed memory elements of the example of **FIG. 5**, which are proportional to the programmed states of the respective memory elements M_{114} , M_{124} and M_{134} . The states of the memory elements M_{114} , M_{124} and M_{134} are then given by binary outputs of the sense amplifiers within the circuits 21 that are connected to the respective global bit lines GBL_1 , GBL_2 and GBL_3 . These sense amplifier outputs are then sent over the lines 23 (**FIG. 2**) to the controller 25, which then provides the read data to the host 31.
5. Turn off the select devices (Q_{12} , Q_{22} and Q_{32}) by removing the voltage from the select gate line (SG_2), in order to disconnect the local bit lines from the global bit lines, and return the selected word line (WL_{12}) to the voltage V_R .

[0069] Parasitic currents during such a read operation have two undesirable effects. As with programming, parasitic currents place increased demands on the memory system power supply. In addition, it is possible for parasitic currents to exist that are erroneously included in the currents through the addressed memory elements that are being read. This can therefore lead to erroneous read results if such parasitic currents are large enough.

[0070] As in the programming case, all of the local bit lines except the selected row (LBL_{12} , LBL_{22} and LBL_{32} in the example of **FIG. 5**) are floating. But the potential of the floating local bit lines may be driven to V_R by any memory element that is in its programmed (low resistance) state and connected between a floating local bit line and a word line at V_R , in any plane. A parasitic current comparable to I_{P1} in the programming case (**FIG. 4**) is not present during data read because both the selected local bit lines and the adjacent non-selected word lines are both at V_R . Parasitic currents may flow, however, through low resistance memory elements connected between floating local bit lines and the selected word line. These are comparable to the currents I_{P2} , I_{P3} , and I_{P4} during programming (**FIG. 4**), indicated

as I_{P5} , I_{P6} and I_{P7} in **FIG. 5**. Each of these currents can be equal in magnitude to the maximum read current through an addressed memory element. However, these parasitic currents are flowing from the word lines at the voltage V_R to the selected word line at a voltage $V_R \pm V_{sense}$ without flowing through the sense amplifiers. These parasitic currents will not flow through the selected local bit lines (LBL_{12} , LBL_{22} and LBL_{32} in **FIG. 5**) to which the sense amplifiers are connected. Although they contribute to power dissipation, these parasitic currents do not therefore introduce a sensing error.

[0071] Although the neighboring word lines should be at V_R to minimize parasitic currents, as in the programming case it may be desirable to weakly drive these word lines or even allow them to float. In one variation, the selected word line and the neighboring word lines can be pre-charged to V_R and then allowed to float. When the sense amplifier is energized, it may charge them to V_R so that the potential on these lines is accurately set by the reference voltage from the sense amplifier (as opposed to the reference voltage from the word line driver). This can occur before the selected word line is changed to $V_R \pm V_{sense}$ but the sense amplifier current is not measured until this charging transient is completed.

[0072] Reference cells may also be included within the memory array 10 to facilitate any or all of the common data operations (erase, program, or read). A reference cell is a cell that is structurally as nearly identical to a data cell as possible in which the resistance is set to a particular value. They are useful to cancel or track resistance drift of data cells associated with temperature, process non-uniformities, repeated programming, time or other cell properties that may vary during operation of the memory. Typically they are set to have a resistance above the highest acceptable low resistance value of a memory element in one data state (such as the ON resistance) and below the lowest acceptable high resistance value of a memory element in another data state (such as the OFF resistance). Reference cells may be "global" to a plane or the entire array, or may be contained within each block or page.

[0073] In one embodiment, multiple reference cells may be contained within each page. The number of such cells may be only a few (less than 10), or may be up to a several percent of the total number of cells within each page. In this case, the reference cells are typically reset and written in a separate operation independent of

the data within the page. For example, they may be set one time in the factory, or they may be set once or multiple times during operation of the memory array. During a reset operation described above, all of the global bit lines are set low, but this can be modified to only set the global bit lines associated with the memory elements being reset to a low value while the global bit lines associated with the reference cells are set to an intermediate value, thus inhibiting them from being reset. Alternately, to reset reference cells within a given block, the global bit lines associated with the reference cells are set to a low value while the global bit lines associated with the data cells are set to an intermediate value. During programming, this process is reversed and the global bit lines associated with the reference cells are raised to a high value to set the reference cells to a desired ON resistance while the memory elements remain in the reset state. Typically the programming voltages or times will be changed to program reference cells to a higher ON resistance than when programming memory elements.

[0074] If, for example, the number of reference cells in each page is chosen to be 1% of the number of data storage memory elements, then they may be physically arranged along each word line such that each reference cell is separated from its neighbor by 100 data cells, and the sense amplifier associated with reading the reference cell can share its reference information with the intervening sense amplifiers reading data. Reference cells can be used during programming to ensure the data is programmed with sufficient margin. Further information regarding the use of reference cells within a page can be found in United States patents nos. 6,222,762, 6,538,922, 6,678,192 and 7,237,074.

[0075] In a particular embodiment, reference cells may be used to approximately cancel parasitic currents in the array. In this case the value of the resistance of the reference cell(s) is set to that of the reset state rather than a value between the reset state and a data state as described earlier. The current in each reference cell can be measured by its associated sense amplifier and this current subtracted from neighboring data cells. In this case, the reference cell is approximating the parasitic currents flowing in a region of the memory array that tracks and is similar to the parasitic currents flowing in that region of the array during a data operation. This correction can be applied in a two step operation (measure the

parasitic current in the reference cells and subsequently subtract its value from that obtained during a data operation) or simultaneously with the data operation. One way in which simultaneous operation is possible is to use the reference cell to adjust the timing or reference levels of the adjacent data sense amplifiers. An example of this is shown in United States patent no. 7,324,393.

[0076] In conventional two-dimensional arrays of variable resistance memory elements, a diode is usually included in series with the memory element between the crossing bit and word lines. The primary purpose of the diodes is to reduce the number and magnitudes of parasitic currents during resetting (erasing), programming and reading the memory elements. A significant advantage of the three-dimensional array herein is that resulting parasitic currents are fewer and therefore have a reduced negative effect on operation of the array than in other types of arrays.

[0077] Diodes may also be connected in series with the individual memory elements of the three-dimensional array, as currently done in other arrays of variable resistive memory elements, in order to reduce further the number of parasitic currents but there are disadvantages in doing so. Primarily, the manufacturing process becomes more complicated. Added masks and added manufacturing steps are then necessary. Also, since formation of the silicon p-n diodes often requires at least one high temperature step, the word lines and local bit lines cannot then be made of metal having a low melting point, such as aluminum that is commonly used in integrated circuit manufacturing, because it may melt during the subsequent high temperature step. Use of a metal, or composite material including a metal, is preferred because of its higher conductivity than the conductively doped polysilicon material that is typically used for bit and word lines because of being exposed to such high temperatures. An example of an array of resistive switching memory elements having a diode formed as part of the individual memory elements is given in patent application publication no. US 2009/0001344 A1.

[0078] Because of the reduced number of parasitic currents in the three-dimensional array herein, the total magnitude of parasitic currents can be managed without the use of such diodes. In addition to the simpler manufacturing processes, the absence of the diodes allows bi-polar operation; that is, an operation in which the voltage polarity to switch the memory element from its first state to its second

memory state is opposite of the voltage polarity to switch the memory element from its second to its first memory state. The advantage of the bi-polar operation over a unipolar operation (same polarity voltage is used to switch the memory element from its first to second memory state as from its second to first memory state) is the reduction of power to switch the memory element and an improvement in the reliability of the memory element. These advantages of the bi-polar operation are seen in memory elements in which formation and destruction of a conductive filament is the physical mechanism for switching, as in the memory elements made from metal oxides and solid electrolyte materials.

[0079] The level of parasitic currents increases with the number of planes and with the number of memory elements connected along the individual word lines within each plane. But since the number of word lines on each plane does not significantly affect the amount of parasitic current, the planes may individually include a large number of word lines. The parasitic currents resulting from a large number of memory elements connected along the length of individual word lines can further be managed by segmenting the word lines into sections of fewer numbers of memory elements. Erasing, programming and reading operations are then performed on the memory elements connected along one segment of each word line instead of the total number of memory elements connected along the entire length of the word line.

[0080] The re-programmable non-volatile memory array being described herein has many advantages. The quantity of digital data that may be stored per unit of semiconductor substrate area is high. It may be manufactured with a lower cost per stored bit of data. Only a few masks are necessary for the entire stack of planes, rather than requiring a separate set of masks for each plane. The number of local bit line connections with the substrate is significantly reduced over other multi-plane structures that do not use the vertical local bit lines. The architecture eliminates the need for each memory cell to have a diode in series with the resistive memory element, thereby further simplifying the manufacturing process and enabling the use of metal conductive lines. Also, the voltages necessary to operate the array are much lower than those used in current commercial flash memories.

[0081] Since at least one-half of each current path is vertical, the voltage drops present in large cross-point arrays are significantly reduced. The reduced length of the current path due to the shorter vertical component means that there are approximately one-half the number memory cells on each current path and thus the leakage currents are reduced as is the number of unselected cells disturbed during a data programming or read operation. For example, if there are N cells associated with a word line and N cells associated with a bit line of equal length in a conventional array, there are 2N cells associated or "touched" with every data operation. In the vertical local bit line architecture described herein, there are n cells associated with the bit line (n is the number of planes and is typically a small number such as 4 to 8), or N+n cells are associated with a data operation. For a large N this means that the number of cells affected by a data operation is approximately one-half as many as in a conventional three-dimensional array.

Materials Useful for the Memory Storage Elements

[0082] The material used for the non-volatile memory storage elements M_{zxy} in the array of **FIG. 1** can be a chalcogenide, a metal oxide, or any one of a number of materials that exhibit a stable, reversible shift in resistance in response to an external voltage applied to or current passed through the material.

[0083] Metal oxides are characterized by being insulating when initially deposited. One suitable metal oxide is a titanium oxide (TiO_x). A previously reported memory element using this material is illustrated in **FIG. 6**. In this case, near-stoichiometric TiO_2 bulk material is altered in an annealing process to create an oxygen deficient layer (or a layer with oxygen vacancies) in proximity of the bottom electrode. The top platinum electrode, with its high work function, creates a high potential Pt/ TiO_2 barrier for electrons. As a result, at moderate voltages (below one volt), a very low current will flow through the structure. The bottom Pt/ TiO_{2-x} barrier is lowered by the presence of the oxygen vacancies (O^{+}_2) and behaves as a low resistance contact (ohmic contact). (The oxygen vacancies in TiO_2 are known to act as n-type dopant, transforming the insulating oxide in an electrically conductive

doped semiconductor.) The resulting composite structure is in a non-conductive (high resistance) state.

[0084] But when a large negative voltage (such as 1.5 volt) is applied across the structure, the oxygen vacancies drift toward the top electrode and, as a result, the potential barrier Pt/TiO₂ is reduced and a relatively high current can flow through the structure. The device is then in its low resistance (conductive) state. Experiments reported by others have shown that conduction is occurring in filament-like regions of the TiO₂, perhaps along grain boundaries.

[0085] The conductive path is broken by applying a large positive voltage across the structure of FIG. 6. Under this positive bias, the oxygen vacancies move away from the proximity of the top Pt/TiO₂ barrier, and “break” the filament. The device returns to its high resistance state. Both of the conductive and non-conductive states are non-volatile. Sensing the conduction of the memory storage element by applying a voltage around 0.5 volts can easily determine the state of the memory element.

[0086] While this specific conduction mechanism may not apply to all metal oxides, as a group, they have a similar behavior: transition from a low conductive state to a high conductive occurs state when appropriate voltages are applied, and the two states are non-volatile. Examples of other materials include HfO_x, ZrO_x, WO_x, NiO_x, CoO_x, CoalO_x, MnO_x, ZnMn₂O₄, ZnO_x, TaO_x, NbO_x, HfSiO_x, HfAlO_x. Suitable top electrodes include metals with a high work function (typically > 4.5 eV) capable to getter oxygen in contact with the metal oxide to create oxygen vacancies at the contact. Some examples are TaCN, TiCN, Ru, RuO, Pt, Ti rich TiO_x, TiAlN, TaAlN, TiSiN, TaSiN, IrO₂. Suitable materials for the bottom electrode are any conducting oxygen rich material such as Ti(O)N, Ta(O)N, TiN and TaN. The thicknesses of the electrodes are typically 1 nm or greater. Thicknesses of the metal oxide are generally in the range of 5 nm to 50 nm.

[0087] Another class of materials suitable for the memory storage elements is solid electrolytes but since they are electrically conductive when deposited, individual memory elements need to be formed and isolated from one another. Solid electrolytes are somewhat similar to the metal oxides, and the conduction mechanism is assumed

to be the formation of a metallic filament between the top and bottom electrode. In this structure the filament is formed by dissolving ions from one electrode (the oxidizable electrode) into the body of the cell (the solid electrolyte). In one example, the solid electrolyte contains silver ions or copper ions, and the oxidizable electrode is preferably a metal intercalated in a transition metal sulfide or selenide material such as $A_x(MB_2)_{1-x}$, where A is Ag or Cu, B is S or Se, and M is a transition metal such as Ta, V, or Ti, and x ranges from about 0.1 to about 0.7. Such a composition minimizes oxidizing unwanted material into the solid electrolyte. One example of such a composition is $Ag_x(TaS_2)_{1-x}$. Alternate composition materials include α -AgI. The other electrode (the indifferent or neutral electrode) should be a good electrical conductor while remaining insoluble in the solid electrolyte material. Examples include metals and compounds such as W, Ni, Mo, Pt, metal silicides, and the like.

[0088] Examples of solid electrolytes materials are: TaO, GeSe or GeS. Other systems suitable for use as solid electrolyte cells are: Cu/TaO/W, Ag/GeSe/W, Cu/GeSe/W, Cu/GeS/W, and Ag/GeS/W, where the first material is the oxidizable electrode, the middle material is the solid electrolyte, and the third material is the indifferent (neutral) electrode. Typical thicknesses of the solid electrolyte are between 30 nm and 100 nm.

[0089] In recent years, carbon has been extensively studied as a non-volatile memory material. As a non-volatile memory element, carbon is usually used in two forms, conductive (or grapheme like-carbon) and insulating (or amorphous carbon). The difference in the two types of carbon material is the content of the carbon chemical bonds, so called sp^2 and sp^3 hybridizations. In the sp^3 configuration, the carbon valence electrons are kept in strong covalent bonds and as a result the sp^3 hybridization is non-conductive. Carbon films in which the sp^3 configuration dominates, are commonly referred to as tetrahedral-amorphous carbon, or diamond like. In the sp^2 configuration, not all the carbon valence electrons are kept in covalent bonds. The weak tight electrons (π bonds) contribute to the electrical conduction making the mostly sp^2 configuration a conductive carbon material. The operation of the carbon resistive switching nonvolatile memories is based on the fact that it is possible to transform the sp^3 configuration to the sp^2 configuration by applying appropriate current (or voltage) pulses to the carbon structure. For example, when a

very short (1 - 5 ns) high amplitude voltage pulse is applied across the material, the conductance is greatly reduced as the material sp^2 changes into an sp^3 form (“reset” state). It has been theorized that the high local temperatures generated by this pulse causes disorder in the material and if the pulse is very short, the carbon “quenches” in an amorphous state (sp^3 hybridization). On the other hand, when in the reset state, applying a lower voltage for a longer time (~300 nsec) causes part of the material to change into the sp^2 form (“set” state). The carbon resistance switching non-volatile memory elements have a capacitor like configuration where the top and bottom electrodes are made of high temperature melting point metals like W, Pd, Pt and TaN.

[0090] There has been significant attention recently to the application of carbon nanotubes (CNTs) as a non-volatile memory material. A (single walled) carbon nanotube is a hollow cylinder of carbon, typically a rolled and self-closing sheet one carbon atom thick, with a typical diameter of about 1-2 nm and a length hundreds of times greater. Such nanotubes can demonstrate very high conductivity, and various proposals have been made regarding compatibility with integrated circuit fabrication. It has been proposed to encapsulate “short” CNT’s within an inert binder matrix to form a fabric of CNT’s. These can be deposited on a silicon wafer using a spin-on or spray coating, and as applied the CNT’s have a random orientation with respect to each other. When an electric field is applied across this fabric, the CNT’s tend to flex or align themselves such that the conductivity of the fabric is changed. The switching mechanism from low-to-high resistance and the opposite is not well understood. As in the other carbon based resistive switching non-volatile memories, the CNT based memories have capacitor-like configurations with top and bottom electrodes made of high melting point metals such as those mentioned above.

[0091] Yet another class of materials suitable for the memory storage elements is phase-change materials. A preferred group of phase-change materials includes chalcogenide glasses, often of a composition $Ge_xSb_yTe_z$, where preferably $x=2$, $y=2$ and $z=5$. GeSb has also been found to be useful. Other materials include AgInSbTe, GeTe, GaSb, BaSbTe, InSbTe and various other combinations of these basic elements. Thicknesses are generally in the range of 1 nm to 500 nm. The generally accepted explanation for the switching mechanism is that when a high energy pulse is applied for a very short time to cause a region of the material to melt,

the material “quenches” in an amorphous state, which is a low conductive state. When a lower energy pulse is applied for a longer time such that the temperature remains above the crystallization temperature but below the melting temperature, the material crystallizes to form poly-crystal phases of high conductivity. These devices are often fabricated using sub-lithographic pillars, integrated with heater electrodes. Often the localized region undergoing the phase change may be designed to correspond to a transition over a step edge, or a region where the material crosses over a slot etched in a low thermal conductivity material. The contacting electrodes may be any high melting metal such as TiN, W, WN and TaN in thicknesses from 1 nm to 500 nm.

[0092] It will be noted that the memory materials in most of the foregoing examples utilize electrodes on either side thereof whose compositions are specifically selected. In embodiments of the three-dimensional memory array herein where the word lines (WL) and/or local bit lines (LBL) also form these electrodes by direct contact with the memory material, those lines are preferably made of the conductive materials described above. In embodiments using additional conductive segments for at least one of the two memory element electrodes, those segments are therefore made of the materials described above for the memory element electrodes.

[0093] Steering elements are commonly incorporated into controllable resistance types of memory storage elements. Steering elements can be a transistor or a diode. Although an advantage of the three-dimensional architecture described herein is that such steering elements are not necessary, there may be specific configurations where it is desirable to include steering elements. The diode can be a p-n junction (not necessarily of silicon), a metal/insulator/insulator/metal (MIIM), or a Schottky type metal/semiconductor contact but can alternately be a solid electrolyte element. A characteristic of this type of diode is that for correct operation in a memory array, it is necessary to be switched “on” and “off” during each address operation. Until the memory element is addressed, the diode is in the high resistance state (“off” state) and “shields” the resistive memory element from disturb voltages. To access a resistive memory element, three different operations are needed: a) convert the diode from high resistance to low resistance, b) program, read, or reset (erase) the memory element by application of appropriate voltages across or currents

through the diode, and c) reset (erase) the diode. In some embodiments one or more of these operations can be combined into the same step. Resetting the diode may be accomplished by applying a reverse voltage to the memory element including a diode, which causes the diode filament to collapse and the diode to return to the high resistance state.

[0094] For simplicity the above description has consider the simplest case of storing one data value within each cell: each cell is either reset or set and holds one bit of data. However, the techniques of the present application are not limited to this simple case. By using various values of ON resistance and designing the sense amplifiers to be able to discriminate between several of such values, each memory element can hold multiple-bits of data in a multiple-level cell (MLC). The principles of such operation are described in United States patent no. 5,172,338 referenced earlier. Examples of MLC technology applied to three dimensional arrays of memory elements include an article entitled "Multi-bit Memory Using Programmable Metallization Cell Technology" by Kozicki et al., Proceedings of the International Conference on Electronic Devices and Memory, Grenoble, France, June 12-17, 2005, pp. 48-53 and "Time Discrete Voltage Sensing and Iterative Programming Control for a 4F2 Multilevel CBRAM" by Schrogmeier et al. (2007 Symposium on VLSI Circuits).

Specific Structural Examples of the Three-Dimensional Array

[0095] Three alternative semiconductor structures for implementing the three-dimensional memory element array of **FIG. 1** are now described.

[0096] A first example, illustrated in **FIG. 7**, is configured for use of memory element (NVM) material that is non-conductive when first deposited. A metal oxide of the type discussed above has this characteristic. As explained with respect to **FIG. 6**, conductive filaments are formed between electrodes on opposite sides of the material in response to appropriate voltages placed on those electrodes. These electrodes are a bit line and a word line in the array. Since the material is otherwise non-conductive, there is no necessity to isolate the memory elements at the cross-points of the word and bit lines from each other. Several memory elements may be implemented by a single continuous layer of material, which in the case of **FIG. 7** are

strips of NVM material oriented vertically along opposite sides of the vertical bit lines in the y-direction and extending upwards through all the planes. A significant advantage of the structure of **FIG. 7** is that all word lines and strips of insulation under them in a group of planes may be defined simultaneously by use of a single mask, thus greatly simplifying the manufacturing process.

[0097] Referring to **FIG. 7**, a small part of four planes 101, 103, 105 and 107 of the three-dimensional array are shown. Elements of the **FIG. 7** array that correspond to those of the equivalent circuit of **FIG. 1** are identified by the same reference numbers. It will be noted that **FIG. 7** shows the two planes 1 and 2 of **FIG. 1** plus two additional planes on top of them. All of the planes have the same horizontal pattern of gate, dielectric and memory storage element (NVM) material. In each plane, metal word lines (WL) are elongated in the x-direction and spaced apart in the y-direction. Each plane includes a layer of insulating dielectric that isolates its word lines from the word lines of the plane below it or, in the case of plane 101, of the substrate circuit components below it. Extending through each plane is a collection of metal local bit line (LBL) "pillars" elongated in the vertical z-direction and forming a regular array in the x-y direction.

[0098] Each bit line pillar is connected to one of a set of global bit lines (GBL) in the silicon substrate running in the y-direction at the same pitch as the pillar spacing through the select devices (Q_{xy}) formed in the substrate whose gates are driven by the select gate lines (SG) elongated in the x-direction, which are also formed in the substrate. The switching devices Q_{xy} may be conventional CMOS transistors (or vertical npn transistors) and fabricated using the same process as used to form the other conventional circuitry. In the case of using npn transistors instead of MOS transistors, the select gate (SG) lines are replaced with the base contact electrode lines elongated in the x-direction. Also fabricated in the substrate but not shown in **FIG. 7** are sense amplifiers, input-output (I/O) circuitry, control circuitry, and any other necessary peripheral circuitry. There is one select gate line (SG) for each row of local bit line pillars in the x-direction and one select device (Q) for each individual local bit line (LBL).

[0099] Each vertical strip of non-volatile memory element (NVM) material is sandwiched between the vertical local bit lines (LBL) and a plurality of word lines

(WL) vertically stacked in all the planes. Preferably the NVM material is present between the local bit lines (LBL) in the x-direction. A memory storage element (M) is located at each intersection of a word line (WL) and a local bit line (LBL). In the case of a metal oxide described above for the memory storage element material, a small region of the NVM material between an intersecting local bit line (LBL) and word line (WL) is controllably alternated between conductive (set) and non-conductive (reset) states by appropriate voltages applied to the intersecting lines.

[00100] There may also be a parasitic NVM element formed between the LBL and the dielectric between planes. By choosing the thickness of the dielectric strips to be large compared to the thickness of the NVM material layer (that is, the spacing between the local bit lines and the word lines), a field caused by differing voltages between word lines in the same vertical word line stack can be made small enough so that the parasitic element never conducts a significant amount of current. Similarly, in other embodiments, the non-conducting NVM material may be left in place between adjacent local bit lines if the operating voltages between the adjacent LBLs remain below the programming threshold.

[00101] An outline of a process for fabricating the structure of **FIG. 7** is as follows:

1. The support circuitry, including the select devices Q, global bit lines GBL, select gate lines SG and other circuits peripheral to the array, is formed in the silicon substrate in a conventional fashion and the top surface of this circuitry is planarized, such as by etching with use of a layer of etch stop material placed over the circuitry.
2. Alternating layers of dielectric (insulator) and metal are formed as sheets on top of each other and over at least the area of the substrate in which the select devices Q are formed. In the example of **FIG. 7**, four such sheets are formed.
3. These sheets are then etched (isolated) by using a mask formed over the top of them that has slits elongated in the x-direction and spaced apart in the y-direction. All of the material is removed down to the etch stop in order to form the trenches shown in **FIG. 7** in which the local bit line (LBL) pillars and NVM material is later formed. Contact holes are also etched through the

etch stop material layer at the bottom of the trenches to allow access to the drains of the select devices Q at the positions of the subsequently formed pillars. The formation of the trenches also defines the width in the y-direction of the word lines (WL).

4. Non-volatile memory (NVM) material is deposited in thin layers along the sidewalls of these trenches and across the structure above the trenches. This leaves the NVM material along the opposing sidewalls of each of the trenches and in contact with the word line (WL) surfaces that are exposed into the trenches.

5. Metal is then deposited in these trenches in order to make contact with the non-volatile memory (NVM) material. The metal is patterned using a mask with slits in the y-direction. Removal of the metal material by etching through this mask leaves the local bit line (LBL) pillars. The non-volatile memory (NVM) material in the x-direction may also be removed between pillars. The space between pillars in the x-direction is then filled with a dielectric material and planarized back to the top of the structure.

[00102] A significant advantage of the configuration of **FIG. 7** is that only one etching operation through a single mask is required to form the trenches through all the layers of material of the planes at one time. However, process limitations may limit the number of planes that can be etched together in this manner. If the total thickness of all the layers is too great, the trench may need to be formed in sequential steps. A first number of layers are etched and, after a second number of layers have been formed on top of the first number of trenched layers, the top layers are subjected to a second etching step to form trenches in them that are aligned with the trenches in the bottom layers. This sequence may be repeated even more times for an implementation having a very large number of layers.

[00103] A second example of implementing the three-dimensional memory cell array of **FIG. 1** is illustrated by **FIG. 8**, and a process of forming this structure is outlined with respect to **FIGs. 9-14**. This structure is configured to use any type of material for the non-volatile memory storage elements, electrically conductive or non-conductive when deposited on the structure, such as those described above. The NVM element is isolated from the LBL and is sandwiched between the bottom metal

electrode and the word line. The bottom electrode makes electrical contact with the LBL while the word line is electrically isolated from the LBL through an insulator. The NVM elements at the intersections of the local bit lines (LBL) and word lines (WL) are electrically isolated from one another in the x and z-directions.

[00104] FIG. 8 shows a portion of each of three planes 111, 113 and 115 of this second structural example on only one side of a local bit line (LBL). The word lines (WL) and memory storage elements (M_{xy}) are defined in each plane as the plane is formed, using two masking steps. The local bit lines crossing each plane of the group in the z-direction are defined globally after the last plane in the group is defined. A significant feature of the structure of FIG. 8 is that the storage elements M_{xy} are below their respective word lines, rather than serving as an insulator between the word lines (WL) and the vertical local bit lines (LBL) as done in the example of FIG. 7. Further, a bottom electrode contacts the lower surface of each storage element M_{xy} and extends laterally in the y-direction to the local bit line (LBL). Conduction through one of the memory cells is through the bit line, laterally along the bottom electrode, vertically in the z-direction through the switching material of the storage elements M_{xy} (and optional layer of barrier metal, if present) and to the selected word line (WL). This allows the use of conductive switching material for the storage elements M_{zxy} which in the example of FIG. 7 would electrically short word lines in different planes which are vertically above each other. As shown in FIG. 8, the word lines (WL) stop short in the y-direction of the local bit lines (LBL) and do not have the non-volatile memory (NVM) material sandwiched between the word and local bit lines at the same z-location as is the case in the example of FIG. 7. The storage elements M_{xy} are similarly spaced from the local bit lines (LBL), being electrically connected thereto by the bottom electrode.

[00105] An outline of a process for forming one plane of the three-dimensional structure of FIG. 8 with storage elements M_{zxy} in a regular array in the x-y direction is as follows:

- a. Form, on a continuous dielectric (insulator) layer, parallel sets of stacks containing strips of a bottom electrode, switching material and (optionally) a barrier metal, wherein the stacks are elongated in the y-direction and spaced apart in the x-direction. This intermediate structure is shown in

FIG. 9. The process of forming this structure includes sequentially depositing layers of the bottom insulator (to insulate the device from the substrate in layer 111 and from lower planes in layers 113 and 115), a bottom electrode of electrically conducting material (for example, titanium), the switching NVM material layer, a top electrode barrier metal (for example, platinum), followed by a first layer of photoresist material. Pattern the photoresist as a set of horizontal lines and spaces running in the y-direction. The width of the photoresist lines are reduced (the photoresist is “slimmed”) to reduce the width of the lines of mask material so that the spaces between stacks are larger than the width of the lines. This is to compensate for a possible subsequent misalignment of the rows of switching elements between different planes and to allow a common vertical local bit line to make contact to the bottom electrode simultaneously in all planes. This also reduces the size (and thus current) of the switching elements. Using the photoresist as a mask, the stack is etched, stopping on the bottom insulator layer. The photoresist is then removed, and the gaps between rows are filled with another insulator (not shown in **FIG. 9**) and the resulting structure is planarized.

b. With reference to **FIGs. 10-12**, the stacks are separated to form an x-y array of individual memory elements, each containing a bottom electrode joining two adjacent memory elements in the y-direction.

1. Deposit a layer of dielectric (insulator) over the structure.
2. Pattern parallel lines of photoresist running in the x-direction and etch the top insulator layer to form from this layer the parallel strips of insulation I1 shown in **FIG. 10**. This etching is stopped on the barrier metal (or memory material if the barrier metal is not present) and the insulator filling the gaps between the stacks (not shown).

3. Exposed areas of the array thus formed are filled with a second insulator (I2) with different etching properties than insulator I1, which is then planarized. The result is illustrated in **FIG. 11**.

4. Thereafter, all remaining insulator I1 is removed by selective etching that uses the exposed I2 as a mask. Spacers are then formed along the edges of I2 as illustrated in **FIG. 12**.

5. Using the spacers and the I2 strips as a mask, the parallel stacks are etched through, including the bottom electrode strips, thereby isolating the bottom electrode strips by trenches between them so that each strip contacts only two adjacent memory elements M_{zxy} . As an alternative to forming the spacers for use as part of the etch mask, a photoresist mask may be formed instead. However, there is a potential of misalignment of such a photoresist mask and its pitch may not be as small as can be obtained with the user of the spacers.

6. A third insulator layer is then deposited over the structure and into the trenches just etched, and the third insulator layer is etched back to slightly above the height of the exposed switching material, thereby leaving the third insulators I3. The result is shown in **FIG. 12**, a cross-section drawn in the y-direction along one bottom electrode line.

c. The word lines are then formed in the exposed region, making ohmic contact to two adjacent memory elements (this is a Damascene process).

1. The spacers are first removed. The result is shown as **FIG. 13**, a rectangular x-y array of memory stacks (like upward facing pillars), each two adjacent stacks in the y-direction being connected by a common bottom electrode. Not shown for clarity is the insulator I2 filling the area over the bottom electrode between pillars, and the insulator I3 filling the trench between the gaps separating the bottom electrodes and adjacent pillars.

2. Conductive word line material is then deposited, and is removed by CMP so that it fills the exposed trench, stopping on insulator I3 and barrier metal (if present) or memory material. Note that the insulator I2 forms a trench where the conductive word line material is defined (as a damascene process). The word lines (WL) sit over insulator I3 and two adjacent memory stacks (shown here with barrier metal). The resulting structure is shown in **FIG. 14**.

d. The foregoing processing steps are repeated for each plane in the group of planes. Note that the memory elements in one plane will not be exactly aligned with memory elements in another plane because of photolithography misalignment.

e. After the circuit elements of all the planes have been formed, the vertical local bit lines are then formed:

1. A top insulator is deposited above the word lines of the upper plane.

2. Using a photoresist mask, an x-y “contact” pattern is opened for the individual local bit lines, and etching is performed through the group of planes all the way to the substrate. Rows of these openings are aligned parallel to the word lines along the x-direction but are spaced midway in the gaps between word lines in the y-direction. The size of these openings is smaller than the spacing between word lines and aligned in the x-direction to cut through the bottom electrodes in each plane. As the etch moves through each layer of bottom electrodes of the several planes, it separates the bottom electrodes into two segments so that each segment contacts only one memory element. The etching continues to the substrate where it exposes contacts to the select devices Q_{xy} .

3. These holes are then filled with metal to form the local bit lines, and the top surface is planarized so that each local bit line is independent of (electrically separated from) any other local bit line. A barrier metal may be optionally deposited as a part of this process. The resulting structure is shown in the vertical cross-section of **FIG. 8**.

4. Alternatively, instead of etching an x-y “contact” pattern for the local bit lines, slits elongated in x-direction and spaced apart in the y-direction are etched in the I2 oxide regions. Etching is performed through the group of planes, all the way to the substrate forming trenches in which the local bit line pillars are later formed.

5. Metal is then deposited to fill these trenches. The deposited metal makes contact with the bottom electrode of the memory element in all the planes. The metal is then patterned using a mask with slits in the x-direction. Removal of the metal material by etching through this mask leaves the local bit line pillars. The space between pillars in the x-direction is filled with a dielectric material and planarized back to the top of the structure.

[00106] A third specific structural example is shown by **FIG. 15**, which shows a small portion of three planes 121, 123 and 125. The memory storage elements M_{zxy}

are also formed from a conductive switching material. This is a variation of the second example, wherein the memory elements of FIG. 15 individually takes the shape of the bottom electrode and contacts the vertical local bit line (LBL). The bottom electrodes of the example of FIG. 8 are missing from the layers shown in FIG. 15.

[00107] The structure shown in FIG. 15 is made by essentially the same process as that described above for the second example. The main difference is that in the second example, reference to the bottom electrode is replaced in this third example by the switching material, and reference to the switching material of the second embodiment is not used in this third embodiment.

[00108] The second example structure of FIG. 8 is particularly suited to any switching material that as deposited as an insulator or electrical conductor. The third example structure shown in FIG. 15 is suited primarily for switching materials that are deposited as an electrical conductor (phase change materials, carbon materials, carbon nanotubes and like materials). By isolating the switching material such that it does not span the region between two stacks, the possibility of a conductive short between switching elements is eliminated.

EMBODIMENTS WITH REDUCED LEAKAGE CURRENTS

[00109] Conventionally, diodes are commonly connected in series with the variable resistive elements of a memory array in order to reduce leakage currents that can flow through them. The highly compact 3D reprogrammable memory described in the present invention has an architecture that does not require a diode in series with each memory element while able to keep the leakage currents reduced. This is possible with short local vertical bit lines which are selectively coupled to a set of global bit lines. In this manner, the structures of the 3D memory are necessarily segmented and couplings between the individual paths in the mesh are reduced.

[00110] Even if the 3D reprogrammable memory has an architecture that allows reduced current leakage, it is desirable to further reduce them. As described earlier and in connection with FIG. 5, parasitic currents may exist during a read operation and these currents have two undesirable effects. First, they result in higher

power consumption. Secondly, and more seriously, they may occur in the sensing path of the memory element being sensed, cause erroneous reading of the sensed current.

[00111] FIG. 16 illustrates the read bias voltages and current leakage across multiple planes of the 3D memory shown in FIG. 1 and FIG. 3. FIG. 16 is a cross-sectional view across 4 planes along the x-direction of a portion of the perspective 3D view of the memory shown in FIG. 1. It should be clear that while FIG. 1 shows the substrate and 2 planes, FIG. 16 shows the substrate and 4 planes to better illustrate the effect of current leakage from one plane to another.

[00112] In accordance with the general principle described in connection with FIG. 5, when the resistive state of a memory element 200 in FIG. 16 is to be determined, a bias voltage is applied across the memory element and its element current I_{ELEMENT} sensed. The memory element 200 resides on Plane 4 and is accessible by selecting the word line 210 (Sel-WLi) and the local bit line 220 (Sel-LBLj). For example, to apply the bias voltage, the selected word line 210 (Sel-WLi) is set to 0V and the corresponding selected local bit line 220 (Sel-LBLj) is set to a reference such as 0.5V via a turned on select gate 222 by a sense amplifier 240. With all other unselected word line in all planes also set to the reference 0.5V and all unselected local bit lines also set to the reference 0.5V, then the current sensed by the sense amplifier 240 will just be the I_{ELEMENT} of the memory element 200.

[00113] The architecture shown in FIG. 1 and FIG. 16 has the unselected local bit lines (LBLj+1, LBLj+2, ...) and the selected local bit line (Sel-LBLj) all sharing the same global bit line 250 (GBLi) to the sense amplifier 240. During sensing of the memory element 200, the unselected local bit lines can only be isolated from the sense amplifier 240 by having their respective select gate such as gate 232 turned off. In this way, the unselected local bit lines are left floating and will couple to the reference 0.5V by virtue of adjacent nodes which are at 0.5V. However, the adjacent nodes are not exactly at the reference 0.5V. This is due to a finite resistance in each word line (perpendicular to the plane in FIG. 16) which results in a progressive voltage drop away from one end of the word line at which 0.5V is applied. This ultimately results in the floating, adjacent unselected local bit lines coupling to a voltage slightly different from the reference 0.5V. In this instance, there will be

leakage currents between the selected and unselected local bit lines as illustrated by broken flow lines in **FIG. 16**. Then sensed current is then $I_{\text{ELEMENT}} + \text{leakage currents}$ instead of just I_{ELEMENT} . This problem becomes worse will increasing word line's length and resistivity.

DOUBLE-GLOBAL-BIT-LINE ARCHITECTURE

[00114] According to one aspect of the invention, a 3D memory includes memory elements arranged in a three-dimensional pattern defined by rectangular coordinates having x, y and z-directions and with a plurality of parallel planes stacked in the z-direction. The memory elements in each plane are accessed by a plurality of word lines and local bit lines in tandem with a plurality of global bit lines. The plurality of local bit lines are in the z-direction through the plurality of planes and arranged in a two dimensional rectangular array of rows in the x-direction and columns in the y-directions. The plurality of word lines in each plane are elongated in the x-direction and spaced apart in the y-direction between and separated from the plurality of local bit lines in the individual planes. A non-volatile, reprogramming memory element is located near a crossing between a word line and local bit line and accessible by the word line and bit line and wherein a group of memory elements are accessible in parallel by a common word line and a row of local bit lines. The 3D memory further includes a double-global-bit line architecture with two global bit lines respectively serving even and odd local bit lines in a column thereof in the y-direction. This architecture allows one global bit line to be used by a sense amplifier to access a selected local bit line and the other global bit line to be used to access an unselected local bit lines adjacent the selected local bit line in the y-direction. In this way the adjacent, unselected local lines can be set to exactly a reference voltage same as that of the selected local bit line in order to eliminate leakage currents between adjacent bit lines.

[00115] **FIG. 17** illustrates a three-dimensional memory with a double-global-bit-line architecture for improved access to a set of local bit lines. An architecture of a three-dimensional memory 10' is schematically and generally illustrated in the form of an equivalent circuit of a portion of such a memory. This is a specific example of the three-dimensional array summarized above. A standard three-dimensional

rectangular coordinate system 11 is used for reference, the directions of each of vectors x , y and z being preferably orthogonal with the other two and having a plurality of parallel planes stacked in the z -direction. The local bit lines are elongated vertically, in the z -direction, and form a regular two-dimensional array in the x (row) and y (column) directions.

[00116] Memory storage elements M_{zxy} are formed in a plurality of planes positioned at different distances in the z -direction above the substrate 13. Two planes 1 and 2 are illustrated in **FIG. 17** but there will typically be more, such as 4, 6 or even more. In each plane at distance z , word lines WL_{zy} are elongated in the x -direction and spaced apart in the y -direction between the local bit-lines (LBL_{xy}). Each row of local bit lines LBL_{xy} of each plane is sandwiched by a pair of word lines WL_{zy} and WL_{zy+1} . Individually crossing between a local bit line a word line occurs at each plane where the local bit line intersects the plane. The individual memory storage elements M_{zxy} are connected between one local bit line LBL_{xy} and one word line WL_{zy} adjacent these individual crossings. An individual memory element M_{zxy} is therefore addressable by placing proper voltages on the local bit line LBL_{xy} and word line WL_{zy} between which the memory element is connected. The voltages are chosen to provide the electrical stimulus necessary to cause the state of the memory element to change from an existing state to the desired new state. The levels, duration and other characteristics of these voltages depend upon the material that is used for the memory elements.

[00117] Each “plane” of the three-dimensional memory cell structure is typically formed of at least two layers, one in which the conductive word lines WL_{zy} are positioned and another of a dielectric material that electrically isolates the planes from each other. Additional layers may also be present in each plane, depending for example on the structure of the memory elements M_{zxy} . The planes are stacked on top of each other on a semiconductor substrate with the local bit lines LBL_{xy} being connected with storage elements M_{zxy} of each plane through which the local bit lines extend.

[00118] Essentially the three-dimensional memory 10' shown in **FIG. 17** is similar to the 3D memory 10 shown in **FIG. 1** except for the structure of the global bit lines which has a doubling of the global bit lines.

[00119] A circuit for selectively connecting internal memory elements with external data circuits is preferably formed in a semiconductor substrate 13. In this specific example, a two-dimensional array of select or switching devices Q_{xy} are utilized, where x gives a relative position of the device in the x -direction and y its relative position in the y -direction. The individual devices Q_{xy} may be a select gate or select transistor, as examples.

[00120] A pair of global bit lines (GBL_{xA} , GBL_{xB}) is elongated in the y -direction and have relative positions in the x -direction that are indicated by the subscript. The individual devices Q_{xy} each couples a local bit line to one global bit line. Essentially, each local bit line in a row is coupleable to one of a corresponding pair of global bit lines. Along a column of local bit lines, even local bit lines are coupleable to a first one of a corresponding pair of global bit line while odd local bit lines are coupleable to a second one of the corresponding pair of global bit line.

[00121] Thus, a pair of global bit lines ($GBL_{x'A}$, $GBL_{x'B}$) at about the x' -position, are individually connectable with the source or drain of the select devices Q in such a manner that local bits ($LBL_{x'y}$) at the x' -position and along the y -direction are coupleable alternately to the pair of global bit lines ($GBL_{x'A}$, $GBL_{x'B}$). For example, the odd local bit lines along the column in the y -direction at the $x=1$ position (LBL_{11} , LBL_{13} , ...) are coupleable respectively via select devices (Q_{11} , Q_{13} , ...) to a first one GBL_{1A} of the pair of global bit line at $x=1$. Similarly, the even local bit lines along the same column at the $x=1$ position (LBL_{12} , LBL_{14} , ...) are coupleable respectively via select devices (Q_{12} , Q_{14} , ...) to a second one GBL_{1B} of the pair of global bit line at $x=1$.

[00122] During reading and also typically programming, each global bit line is typically coupled to one local bit line by accessing through a corresponding select device that has been turned on. In this way a sense amplifier can access the local bit line via the coupled global bit line.

[00123] In order to connect one set (in this example, designated as one row) of local bit lines with a corresponding set of global bit lines, control gate lines SG_y are elongated in the x-direction and connect with control terminals (gates) of a single row of select devices Q_{xy} having a common position in the y-direction. In this way, a set or page of memory elements can be accessed in parallel. The select devices Q_{xy} therefore connect one row of local bit lines (LBL_{xy}) across the x-direction (having the same position in the y-direction) at a time to corresponding ones of the global bit lines, depending upon which of the control gate lines SG_y receives a voltage that turns on the select devices to which it is connected. In the double-global-bit line architecture, there is a pair of global bit lines at about each x-position. If a row of local bit lines along the x-directions are coupleable to the first one of each pair of corresponding global bit lines, then along the y-direction, an adjacent row of local bit lines will be coupleable to the second one of each pair of corresponding global bit lines. For example, the row of local bit lines (LBL_{11} , LBL_{21} , LBL_{31} , ...) along the x-direction are coupled to the first of each pair of corresponding global bit lines (GBL_{1A} , GBL_{2A} , GBL_{3A} , ...) by turning on select devices (Q_{11} , Q_{21} , Q_{31} , ...) via the control gate line SG_1 . Along the y-direction, an adjacent row of local bit lines (LBL_{12} , LBL_{22} , LBL_{32} , ...) along the x-direction are coupled to the second of each pair of corresponding global bit lines (GBL_{1B} , GBL_{2B} , GBL_{3B} , ...) by turning on select devices (Q_{12} , Q_{22} , Q_{32} , ...) via the control gate line SG_2 . Similarly, a next adjacent row of local bit lines (LBL_{13} , LBL_{23} , LBL_{33} , ...) are coupled to the first of each pair of corresponding global bit lines (GBL_{1A} , GBL_{2A} , GBL_{3A} , ...) in an alternating manner between the first and second one of each pair.

[00124] By accessing a row of local bit lines and an adjacent row using different ones of each pair of corresponding global bit lines, the row and adjacent row of local bit lines can be accessed independently at the same time. This is in contrast to the case of the single-global-bit-line architecture shown in **FIG. 1**, where both a row and its adjacent row of local bit lines share the same corresponding global bit lines.

[00125] As discussed in connection with **FIG. 16**, the leakage currents due to adjacent rows are not well controlled when the adjacent bit lines can not be set independently to the reference voltage in order to eliminate current leakage.

[00126] FIG. 18 illustrates the elimination of leakage currents in the double-global-line architecture 3D array of FIG. 17. The analysis of leakage current is similar to that described with respect to FIG. 16. However, with the double-global-bit-line architecture, the selected local bit line 220 (Sel-LBL_j) allows the memory element 200 to be sensed by the sense amplifier 240 via the first one of the pair of global bit line GBL_{iA}, which is maintained at a reference voltage (e.g., 0.5V). At the same time, the adjacent local bit line 230 can be accessed independently by the second one of the pair of global bit line GBL_{iB}. This allows the adjacent local bit line 230 to be set to the same reference voltage. Since both the selected local bit line 220 and its adjacent local bit line (along the y-direction) are at the same reference voltage, there will be no leakage currents between the two local bit lines adjacent to each other.

[00127] The double-global-bit-line architecture doubles the number of global bit lines in the memory array compared to the architecture shown in FIG. 1. However, this disadvantage is offset by providing a memory array with less leakage currents among the memory elements.

SINGLE-SIDED WORD LINE ARCHITECTURE

[00128] According to another embodiment of the invention, a 3D memory includes memory elements arranged in a three-dimensional pattern defined by rectangular coordinates having x, y and z-directions and with a plurality of parallel planes stacked in the z-direction. The memory elements in each plane are accessed by a plurality of word lines and local bit lines in tandem with a plurality of global bit lines. The plurality of local bit lines are in the z-direction through the plurality of planes and arranged in a two dimensional rectangular array of rows in the x-direction and columns in the y-directions. The plurality of word lines in each plane are elongated in the x-direction and spaced apart in the y-direction between and separated from the plurality of local bit lines in the individual planes. A non-volatile, reprogramming memory element is located near a crossing between a word line and local bit line and accessible by the word line and bit line and wherein a group of memory elements are accessible in parallel by a common word line and a row of local bit lines. The 3D memory has a single-sided word line architecture with each word

line exclusively connected to one row of memory elements. This is accomplished by providing one word line for each row of memory elements instead of sharing one word line between two rows of memory elements and linking the memory element across the array across the word lines. While the row of memory elements is also being accessed by a corresponding row of local bit lines, there is no extension of coupling for the row of local bit lines beyond the word line.

[00129] A double-sided word line architecture has been described earlier in that each word line is connected to two adjacent rows of memory elements associated with two corresponding rows of local bit lines, one adjacent row along one side of the word line and another adjacent row along the other side. For example, as shown in **FIG. 1** and **FIG. 3**, the word line WL_{12} is connected on one side to a first row (or page) of memory elements ($M_{114}, M_{124}, M_{134}, \dots$) associated respectively with local bit lines ($LBL_{12}, LBL_{22}, LBL_{32}, \dots$) and also connected on another side to a second row (or page) of memory elements ($M_{115}, M_{125}, M_{135}, \dots$) associated respectively with local bit lines ($LBL_{13}, LBL_{23}, LBL_{33}, \dots$)

[00130] **FIG. 19** illustrates schematically a single-sided word line architecture. Each word line is connected to an adjacent row of memory elements associate with one row of local bit lines on only one side.

[00131] The 3D memory array with the double-sided word line architecture illustrated in **FIG. 1** can be modified to the single-sided word line architecture where each word line except ones at an edge of the array will be replaced by a pair of word lines. In this way, each word line is connecting exclusively to one row of memory elements. Thus, the word line WL_{12} shown in **FIG. 1** is now replaced in **FIG. 19** by the pair of word lines WL_{13} and WL_{14} . It will be seen that WL_{13} is connected to one row of memory elements ($M_{114}, M_{124}, M_{134}, \dots$) and WL_{14} is connected to one row of memory elements ($M_{115}, M_{125}, M_{135}, \dots$) As described before, a row of memory elements constitutes a page which is read or written to in parallel.

[00132] **FIG. 20** illustrates one plane and substrate of the 3D array with the single-sided word line architecture. Going from the double-sided word line architecture of **FIG. 3**, similarly, WL_{12} in **FIG. 3** would be replaced by the pair WL_{13}, WL_{14} in **FIG. 20**, etc. In **FIG. 3**, a typical double-sided word line (e.g., WL_{12}) is connected to two rows of memory elements (on both side of the word line). In **FIG.**

20, each single-sided word line (e.g., WL₁₃) is connected to only one row of memory elements.

[00133] **FIG. 20** also illustrates a minimum block of memory elements that is erasable as a unit to be defined by two row of memory elements (M₁₁₃, M₁₂₃, M₁₃₃, ...) and (M₁₁₄, M₁₂₄, M₁₃₄, ...) sharing the same row of local bit lines (e.g., LBL₁₂, LBL₂₂, LBL₃₂, ...)

[00134] **FIG. 21** illustrates the elimination of leakage currents in the single-sided word-line architecture 3-D array of **FIG. 19** and **20**. The analysis of leakage current is similar to that described with respect to **FIG. 16**. However, with the single-sided word-line architecture, the selected local bit line 220 (Sel-LBL_j) is not coupled to an adjacent bit line 230 across the separated word lines 210 and 212. Thus there is no leakage current between adjacent local bit lines and the sense current in the sense amplifier 240 via the global bit line 250 and the local bit line 220 will be just that from the current of the memory element I_{ELEMENT}.

[00135] The single-sided word-line architecture doubles the number of word lines in the memory array compared to the architecture shown in **FIG. 1**. However, this disadvantage is offset by providing a memory array with less leakage currents among the memory elements.

[00136] **FIG. 22** is an isometric view of a portion of the 3D array with the single-sided word line architecture shown in **FIG. 19**. Again, similar to the isometric view for the double-side word line architecture shown in **FIG. 7**, **FIG. 22** is one specific example of implementation for the single-sided word-line architecture. The main difference compared to **FIG. 7** is that each word line is connected to one side to a row of memory elements. As explained earlier, this architecture has the advantage of decoupling bit-line to bit line coupling across the plurality of word lines in the y-direction.

[00137] The 3D array is configured for use of memory element (NVM) material that is non-conductive when first deposited. A metal oxide of the type discussed earlier has this characteristic. As explained with respect to **FIG. 6**, conductive filaments are formed between electrodes on opposite sides of the material in response to appropriate voltages placed on those electrodes. These electrodes are a

bit line and a word line in the array. Since the material is otherwise non-conductive, there is no necessity to isolate the memory elements at the cross-points of the word and bit lines from each other. Several memory elements may be implemented by a single continuous layer of material, which in the case of **FIG. 22** are strips of NVM material oriented vertically along opposite sides of the vertical bit lines in the y-direction and extending upwards through all the planes. A significant advantage of the structure of **FIG. 22** is that all word lines and strips of insulation under them in a group of planes may be defined simultaneously by use of a single mask, thus greatly simplifying the manufacturing process.

[00138] Referring to **FIG. 22**, a small part of four planes 101, 103, 105 and 107 of the three-dimensional array are shown. Elements of the **FIG. 22** array that correspond to those of the equivalent circuit of **FIG. 19** are identified by the same reference numbers. It will be noted that **FIG. 22** shows the two planes 1 and 2 of **FIG. 19** plus two additional planes on top of them. All of the planes have the same horizontal pattern of word lines, dielectric and memory storage element (NVM) material. In each plane, metal word lines (WL) are elongated in the x-direction and spaced apart in the y-direction. Each plane includes a layer of insulating dielectric that isolates its word lines from the word lines of the plane below it or, in the case of plane 101, of the substrate circuit components below it. Extending through each plane is a collection of metal local bit line (LBL) “pillars” elongated in the vertical z-direction and forming a regular array in the x-y direction.

[00139] Each bit line pillar is connected to one of a set of global bit lines (GBL) in the silicon substrate running in the y-direction at the same pitch as the pillar spacing through the select devices (Q_{xy}) formed in the substrate whose gates are driven by the select gate lines (SG) elongated in the x-direction, which are also formed in the substrate. The switching devices Q_{xy} may be conventional CMOS transistors (or vertical npn transistors) and fabricated using the same process as used to form the other conventional circuitry. In the case of using npn transistors instead of MOS transistors, the select gate (SG) lines are replaced with the base contact electrode lines elongated in the x-direction. Also fabricated in the substrate but not shown in **FIG. 22** are sense amplifiers, input-output (I/O) circuitry, control circuitry, and any other necessary peripheral circuitry. There is one select gate line (SG) for

each row of local bit line pillars in the x-direction and one select device (Q) for each individual local bit line (LBL).

[00140] Each vertical strip of non-volatile memory element (NVM) material is sandwiched between the vertical local bit lines (LBL) and a plurality of word lines (WL) vertically stacked in all the planes. Preferably the NVM material is present between the local bit lines (LBL) in the x-direction. A memory storage element (M) is located at each intersection of a word line (WL) and a local bit line (LBL). In the case of a metal oxide described above for the memory storage element material, a small region of the NVM material between an intersecting local bit line (LBL) and word line (WL) is controllably alternated between conductive (set) and non-conductive (reset) states by appropriate voltages applied to the intersecting lines.

[00141] There may also be a parasitic NVM element formed between the LBL and the dielectric between planes. By choosing the thickness of the dielectric strips to be large compared to the thickness of the NVM material layer (that is, the spacing between the local bit lines and the word lines), a field caused by differing voltages between word lines in the same vertical word line stack can be made small enough so that the parasitic element never conducts a significant amount of current. Similarly, in other embodiments, the non-conducting NVM material may be left in place between adjacent local bit lines if the operating voltages between the adjacent LBLs remain below the programming threshold.

[00142] The single-sided word line architecture almost double the number of word line in the memory array compared to the double-sided one. This disadvantage is offset by providing a more partitioned memory array with less leakage currents among the memory elements.

[00143] While the exemplary embodiments have been described using a 3D co-ordinate system preferably with orthogonal axes, other embodiment in which the local bit lines LBL, word lines WL and global bit lines GBL cross at angles different than 90 degrees are also possible and contemplated.

Conclusion

[00144] Although the various aspects of the present invention have been described with respect to exemplary embodiments thereof, it will be understood that

the present invention is entitled to protection within the full scope of the appended claims.

IT IS CLAIMED:

1. A data memory including memory elements arranged in a three-dimensional pattern defined by rectangular coordinates having x, y and z-directions and with a plurality of parallel planes stacked in the z-direction, the memory further comprising:

a plurality of first conductive lines elongated in the z-direction through the plurality of planes and arranged in a two-dimensional rectangular array of rows in the x-direction and columns in the y-direction;

a plurality of second conductive lines elongated in the x-direction across individual planes and spaced apart in the y-direction between and separated from the first plurality of conductive lines in the individual planes, wherein the first and second conductive lines cross adjacent each other at a plurality of locations across the individual planes;

a plurality of non-volatile re-programmable memory elements individually connected between the first and second conductive lines adjacent the crossings thereof at the plurality of locations; and wherein:

a column of first conductive lines in the y-direction is switchably accessed by a corresponding third conductive line pair;

individual first conductive lines of even number in the column are switchably coupled to one line of the corresponding third conductive line pair; and

individual first conductive lines of odd number in the column are switchably coupled to another line of the corresponding third conductive line pair.

2. The memory of claim 1, wherein
the third conductive lines are elongated in the y-direction,
the select devices are arranged to make those of the first conductive lines aligned in the y-direction connectable with selected ones of the plurality of third conductive lines, and

a plurality of control lines extending in the x-direction and individually connected with a plurality of the select devices aligned in the x-direction to enable connection of a plurality of first conductive lines aligned in the x-direction with different ones of the third conductive lines.

3. The memory of either one of claims 1 or 2, wherein the plurality of select devices and the plurality of third conductive lines are formed in a semiconductor substrate and the plurality of planes are formed as a stack over the semiconductor substrate.

4. The memory of any one of claims 1 and 3, wherein the individual memory elements are characterized by including a material that reversibly changes its level of electrical conductance between at least first and second stable levels in response to an electrical stimulus being applied through the first and second conductive lines between which the memory element is connected.

5. The memory of claim 1, wherein memory elements include individual quantities of material adjacent individual ones of the crossings of the first and second conductive lines, the memory elements being separated from one another in all of the x, y and z-directions.

6. The memory of claim 1, wherein the memory elements are additionally positioned to contact the first conductive lines in the y-direction.

7. The memory of claim 1, wherein the individual memory elements are characterized by a level of electrical conductance that changes in response to an electrical stimulus applied thereto.

8. The memory of claim 1, wherein the memory elements are characterized by having at least first and second stable electrically detectable states that are selected by electrical stimuli applied thereto through the first and second conductive lines.

9. The memory of claim 1, additionally comprising a circuit connected to the first and second conductive lines to apply the electrical stimuli to selected ones of the memory elements, the electrical stimuli being applied to cause the selected memory elements to switch from their first to second stable states having substantially

the same magnitude but different polarities as the electrical stimuli applied to cause the memory elements to switch from their second to first stable states.

10. The memory of claim 1, additionally comprising data input-output circuits connected to the third plurality of conductive lines.

11. The memory of claim 10, wherein the data input-output circuits include a plurality of sense amplifiers that are connected with selected ones of the third conductive lines in a manner to provide a binary representation of data carried by the third conductive lines when data are being read from the memory.

12. The memory of claim 10, wherein the data input-output circuits additionally include data programming circuits that apply voltages to the selected ones of the third conductive lines for programming data into at least some of the memory elements connected thereto through the plurality of select devices.

13. A method of operating a re-programmable non-volatile memory system, comprising:

utilizing at least one integrated circuit that includes a three-dimensional pattern of memory elements defined by rectangular coordinates having x, y and z-directions and which comprises:

a plurality of parallel planes stacked in the z-direction on top of a semiconductor substrate;

a plurality of conductive local bit lines elongated in the z-direction through the plurality of planes and arranged in a two-dimensional rectangular array of rows in the x and columns in the y-directions;

a plurality of word lines elongated in the x-direction across individual planes and spaced apart in the y-direction between and separated from the plurality of local bit lines in the individual planes, wherein the local bit lines and word lines cross adjacent each other at a plurality of locations across the individual planes;

a plurality of re-programmable non-volatile memory elements individually connected between the local bit lines and the word lines adjacent the crossings thereof at the plurality of locations; and wherein:

a column of local bit lines in the y-direction is switchably accessed by a corresponding global bit line pair;

individual local bit lines of even number in the column are switchably coupled to one designated line of the corresponding global bit line pair; and

individual local bit lines of odd number in the column are switchably coupled to another designated line of the corresponding global bit line pair;

a first plurality of select devices arranged to individually couple a selected row of local bit lines to a first designated lines of corresponding global bit line pairs in response to a select control signal;

a second plurality of select devices arranged to individually couple an adjacent row of local bit lines to a second designated lines of corresponding global bit lines pairs in response to the select control signal;

applying the select control signal to the first plurality of select devices in order to connect the selected row of local bit lines to the first designated lines of corresponding global bit line pairs;

applying the select control signal to the second plurality of select devices in order to connect the adjacent row of local bit lines to the second designated lines of corresponding global bit line pairs; and

causing a selected one or more of the plurality of memory elements to simultaneously change between their at least first and second states by applying one of the first and second stimuli through the word lines and global bit lines between which the selected one or more of the plurality of memory elements are operably connected.

14. The method of claim 13, wherein applying select control signals includes applying the select control signals to the plurality of select devices in order to connect a row of the local bit lines extending in the x-direction to the global bit lines.

15. The method of claim 14, wherein causing a selected one or more of the plurality of memory elements to simultaneously change between their at least first and

second states includes simultaneously resetting to the first state two rows of memory elements connected to the selected row of local bit lines and along opposite sides thereof in the y-direction by applying the second electrical stimulus to a plurality of the global bit lines and to two of the word lines adjacent the selected row of local bit lines on said opposite sides thereof.

16. The method of claim 14, wherein causing a selected one or more of the plurality of memory elements to simultaneously change between their at least first and second states additionally includes subsequently programming data into one of the two rows of reset memory elements by applying the first electrical stimulus to a plurality of the global bit lines and one of the word lines adjacent the selected row of local bit lines on the side thereof of the one row of memory elements being programmed.

17. The method of claim 14, additionally comprising reading the states of a row of memory elements along one side in the y-direction of the selected row of local bit lines by applying reading electrical stimuli to the global bit lines and word lines such that the states of the memory elements are read from an electrical quantity appearing on the global bit lines.

18. The method of claim 14, wherein causing a selected one or more of the plurality of memory elements to simultaneously change between their at least first and second states additionally includes applying a plurality of pulses of the one of the first and second stimuli and, in between successive pulses, verifying the state of the one or more of the plurality of memory elements.

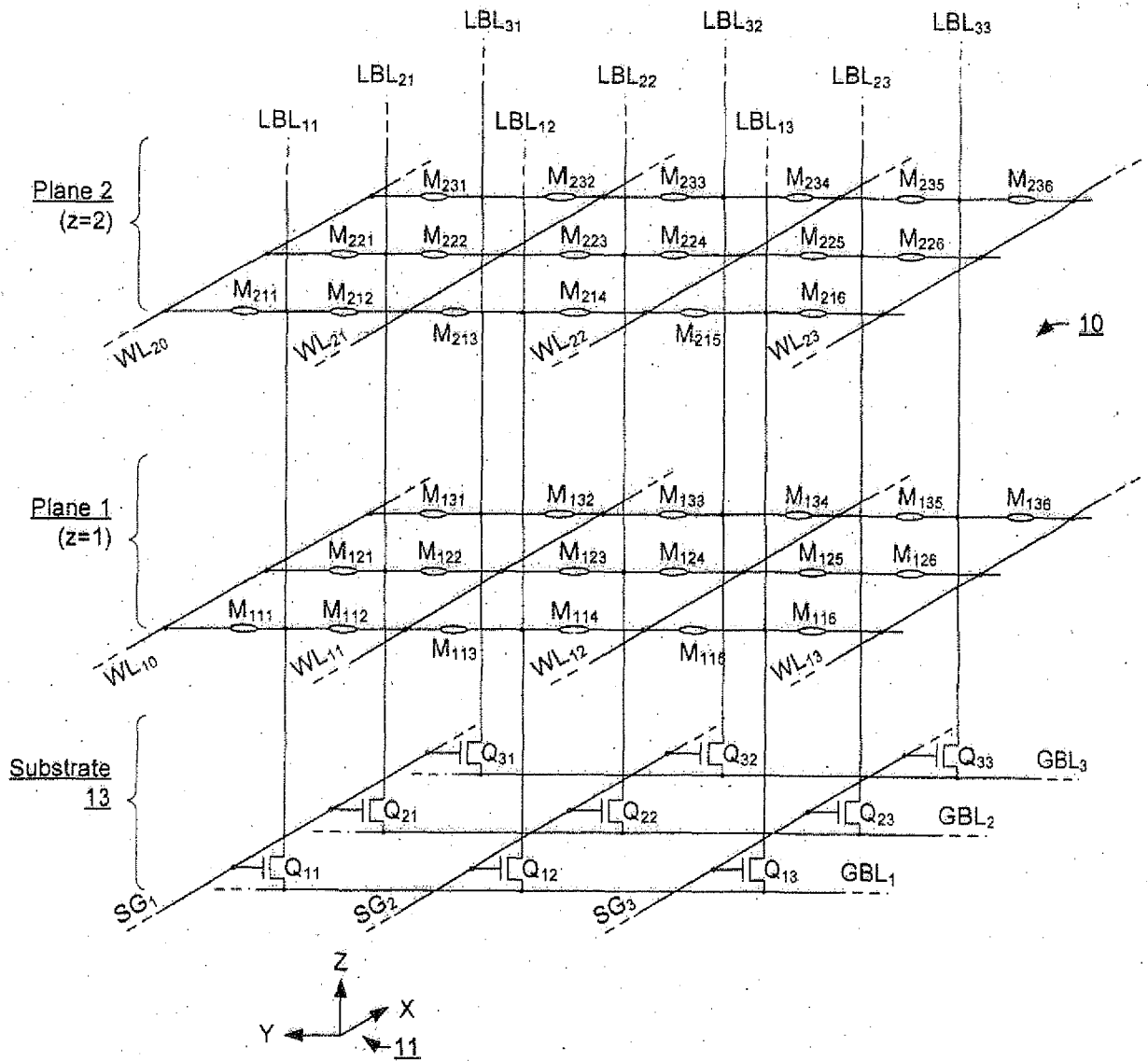

FIG. 1

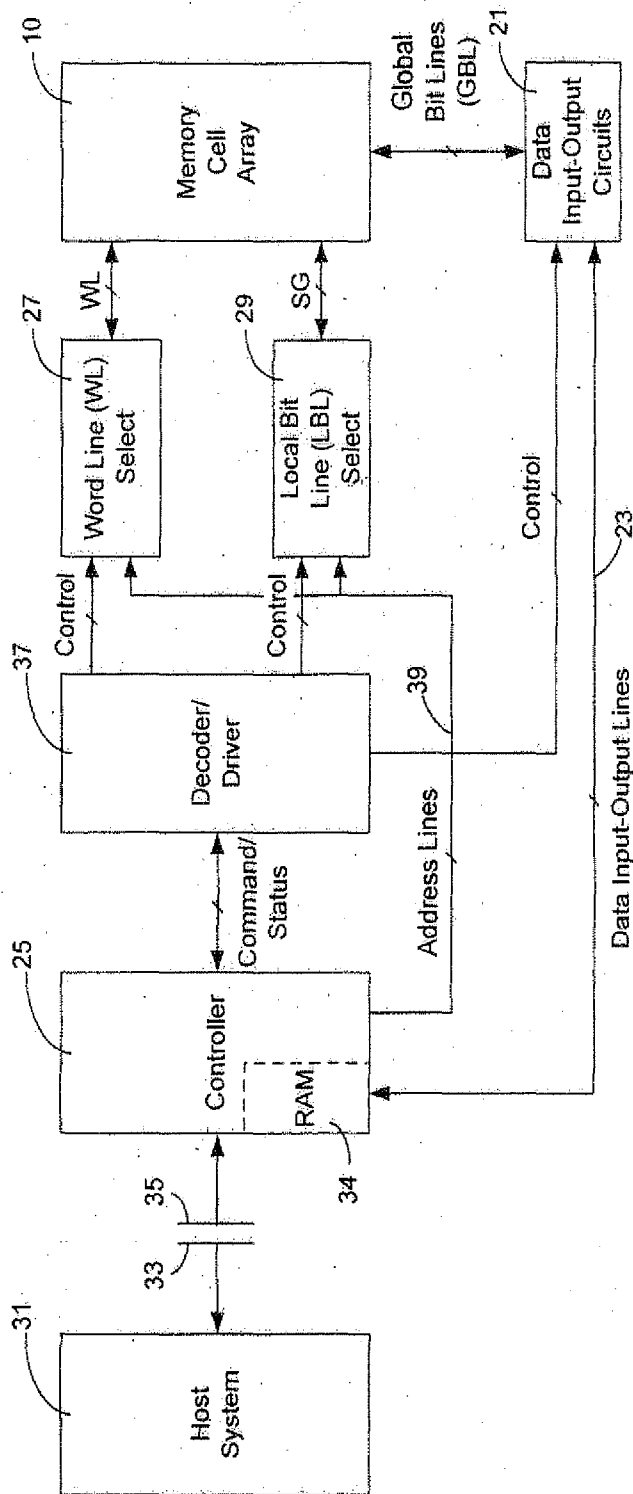
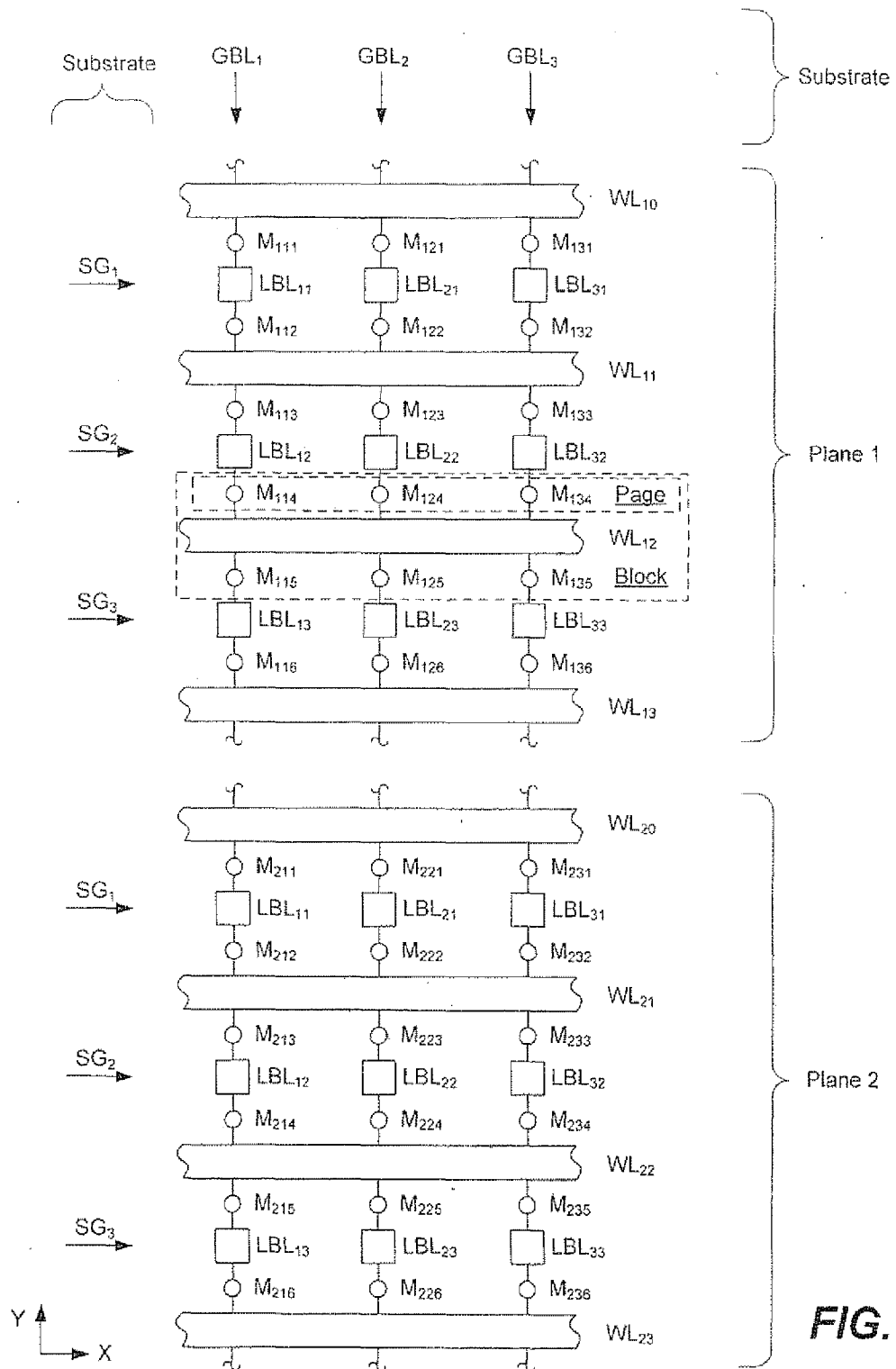
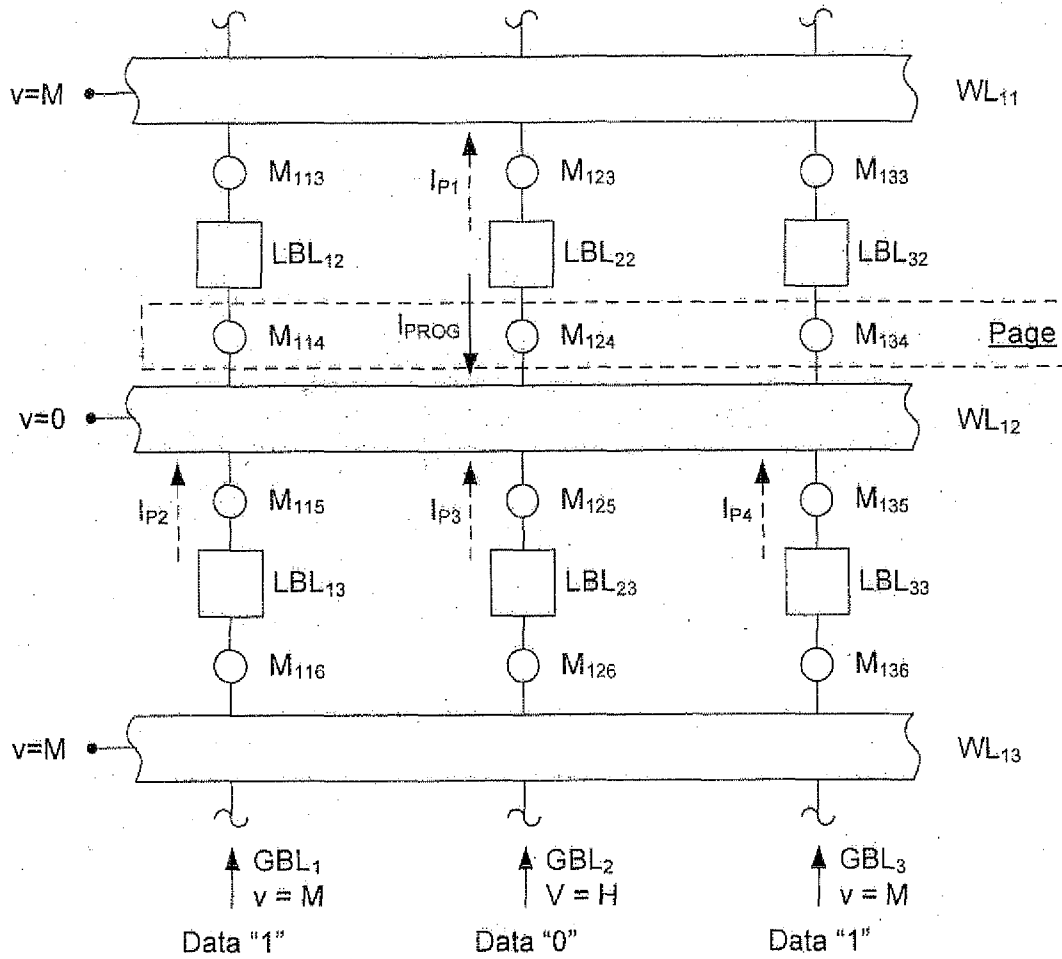

FIG. 2





Programming

FIG. 4

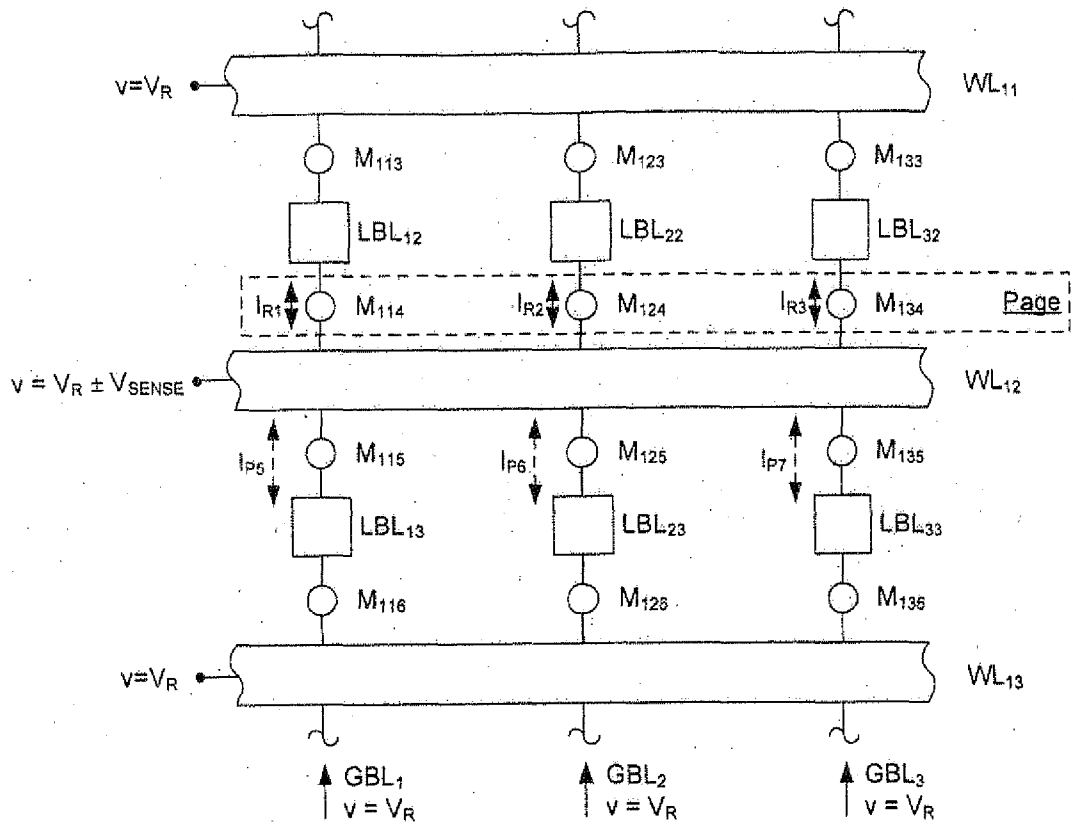

Reading

FIG. 5

6/17

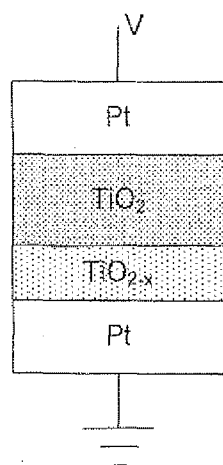

FIG. 6

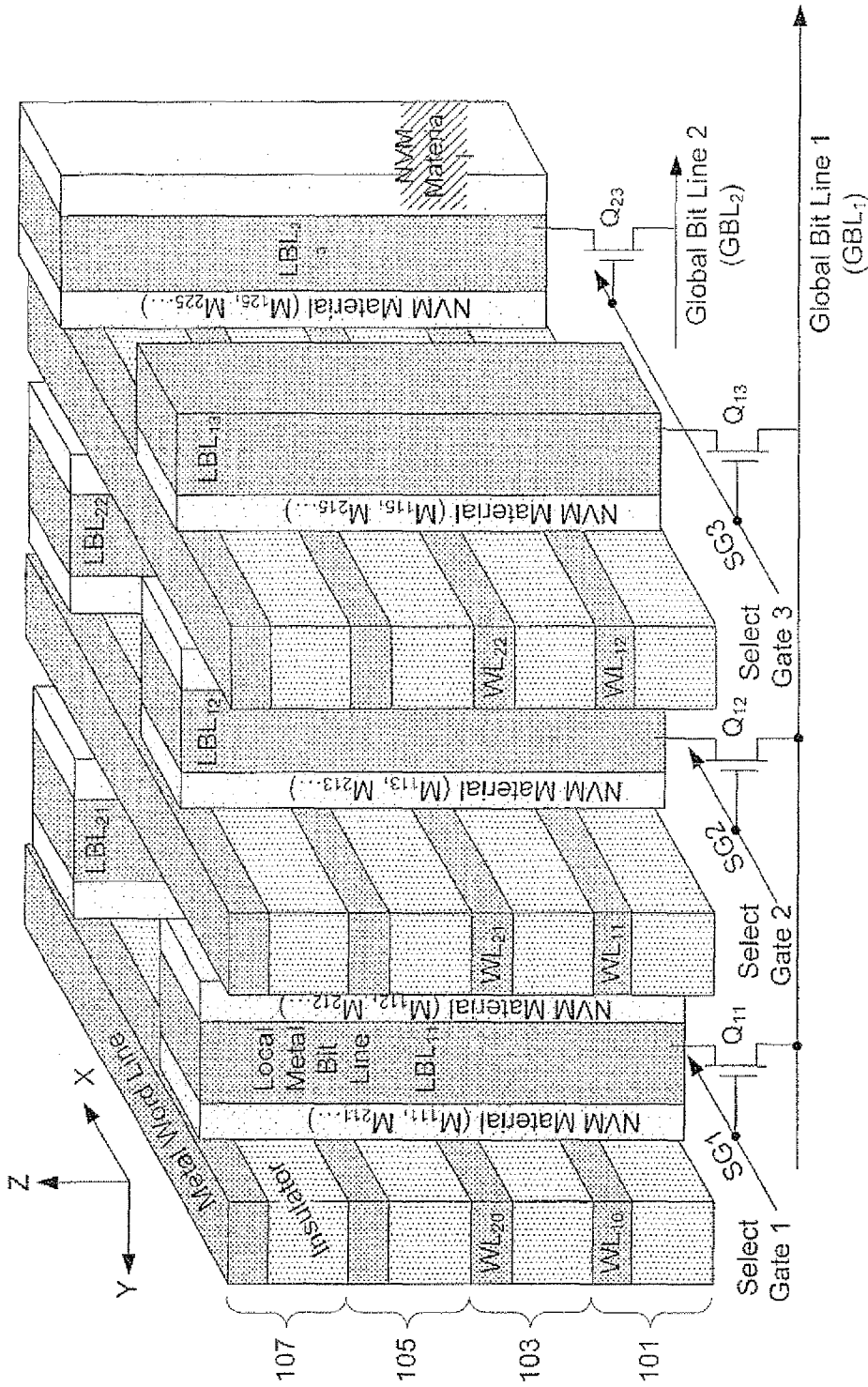

FIG. 7

8/17

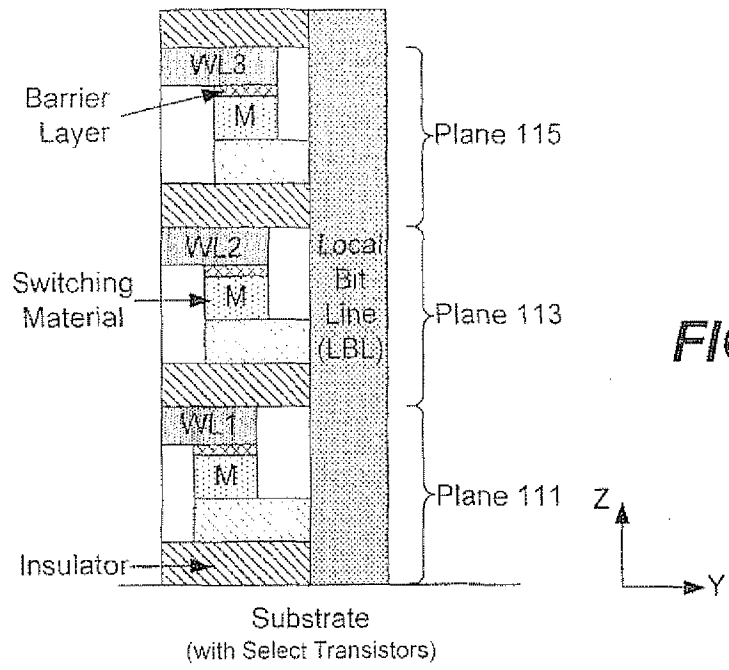

FIG. 8

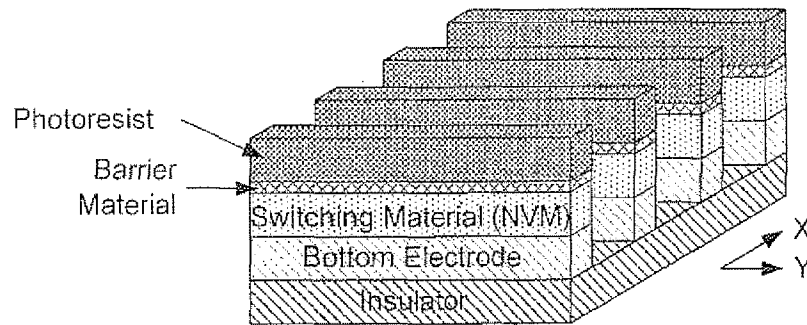

FIG. 9

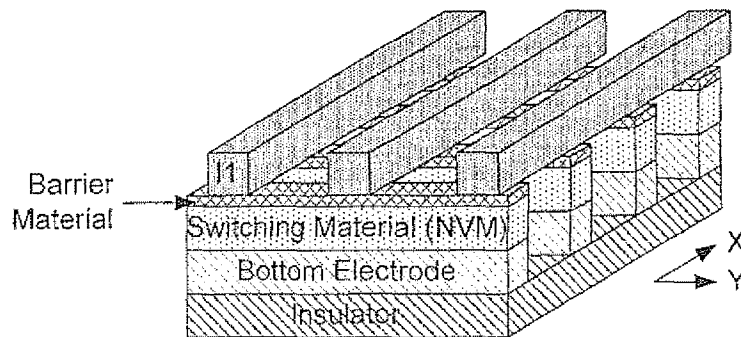

FIG. 10

9/17

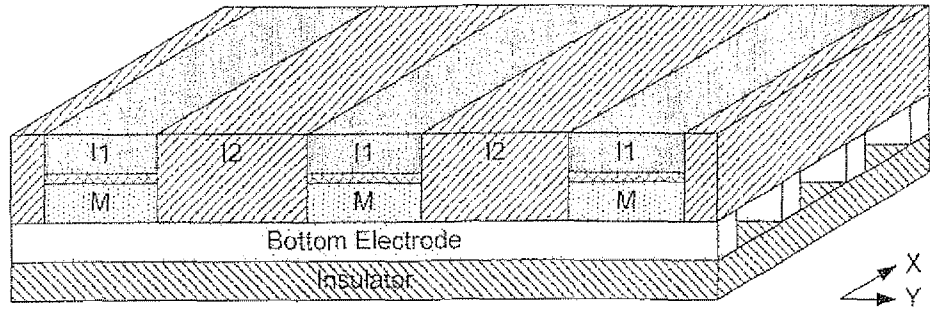

FIG. 11

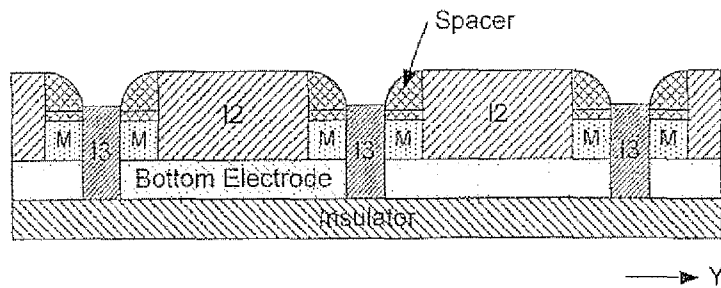

FIG. 12

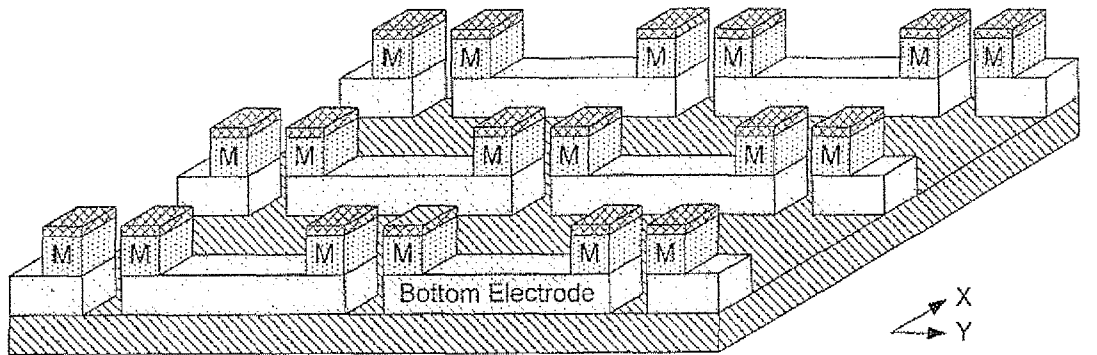

FIG. 13

10/17

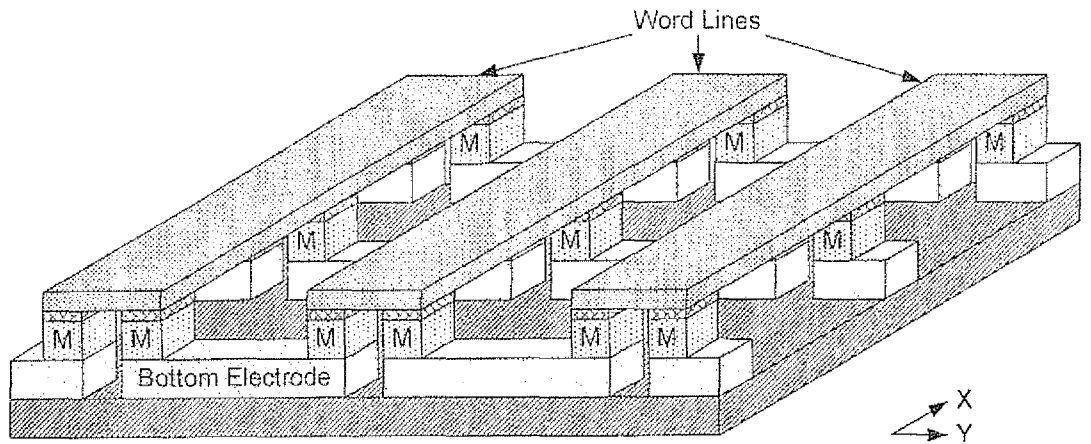

FIG. 14

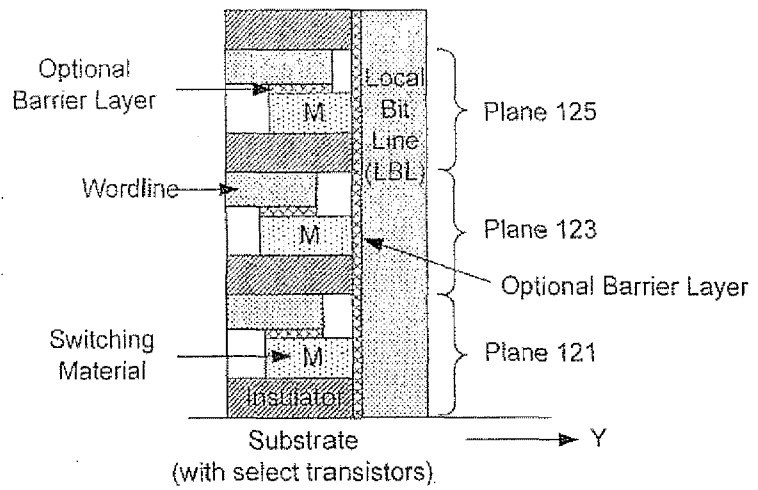
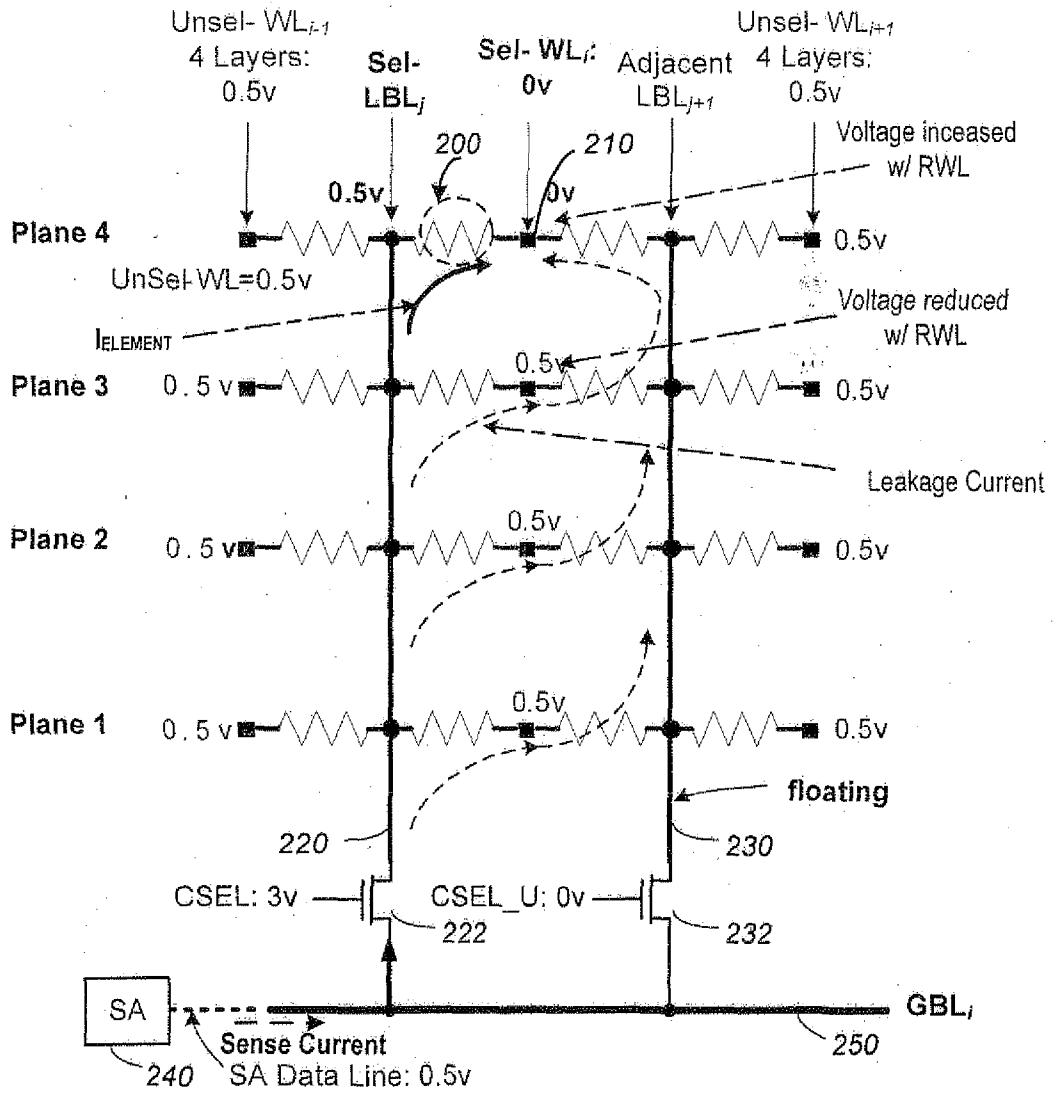
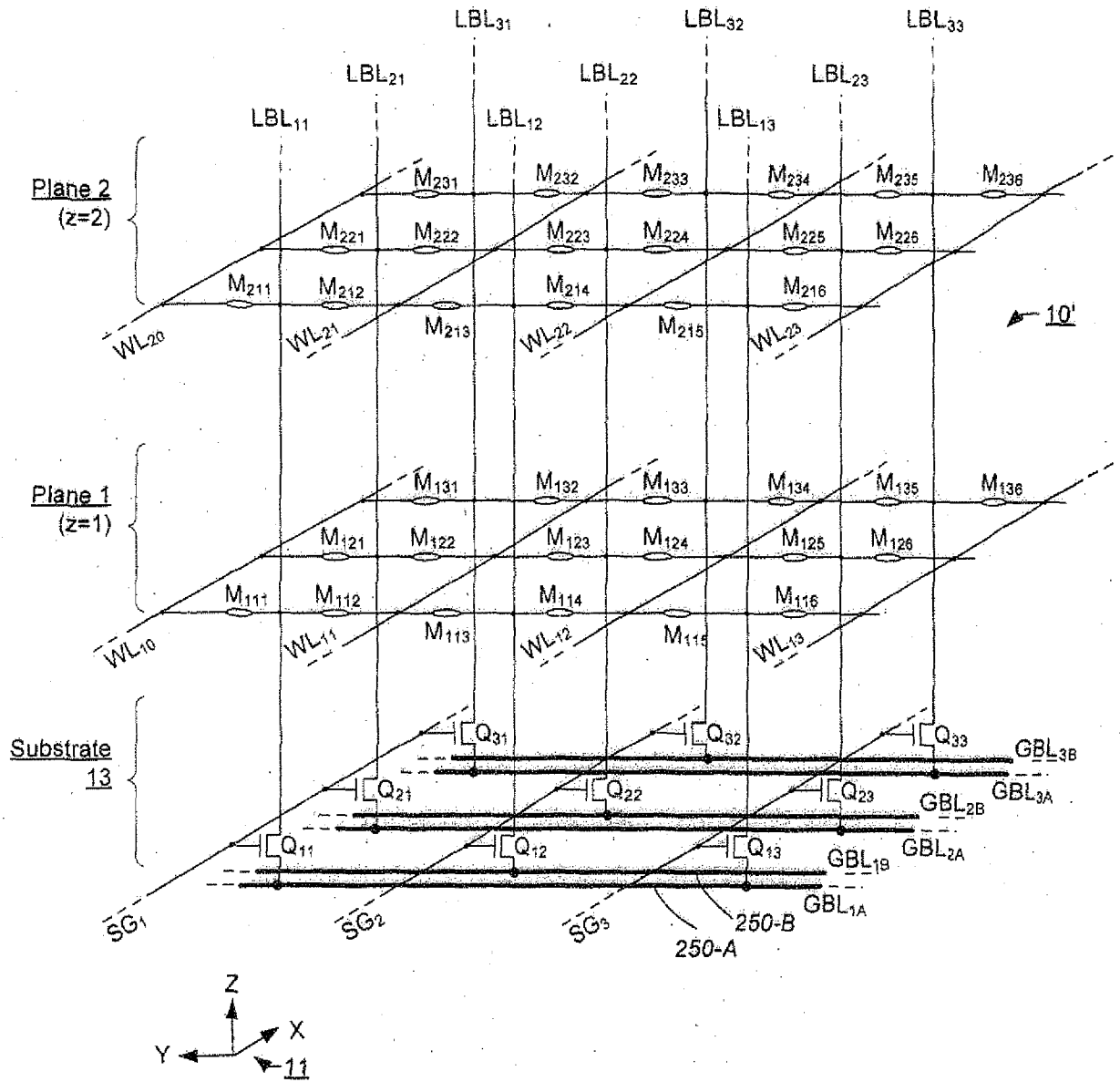

FIG. 15



READ Bias Voltage and Leakage Current Flow in a double-sided word line architecture

FIG. 16



Double-Global-Bit-line Structure

FIG. 17

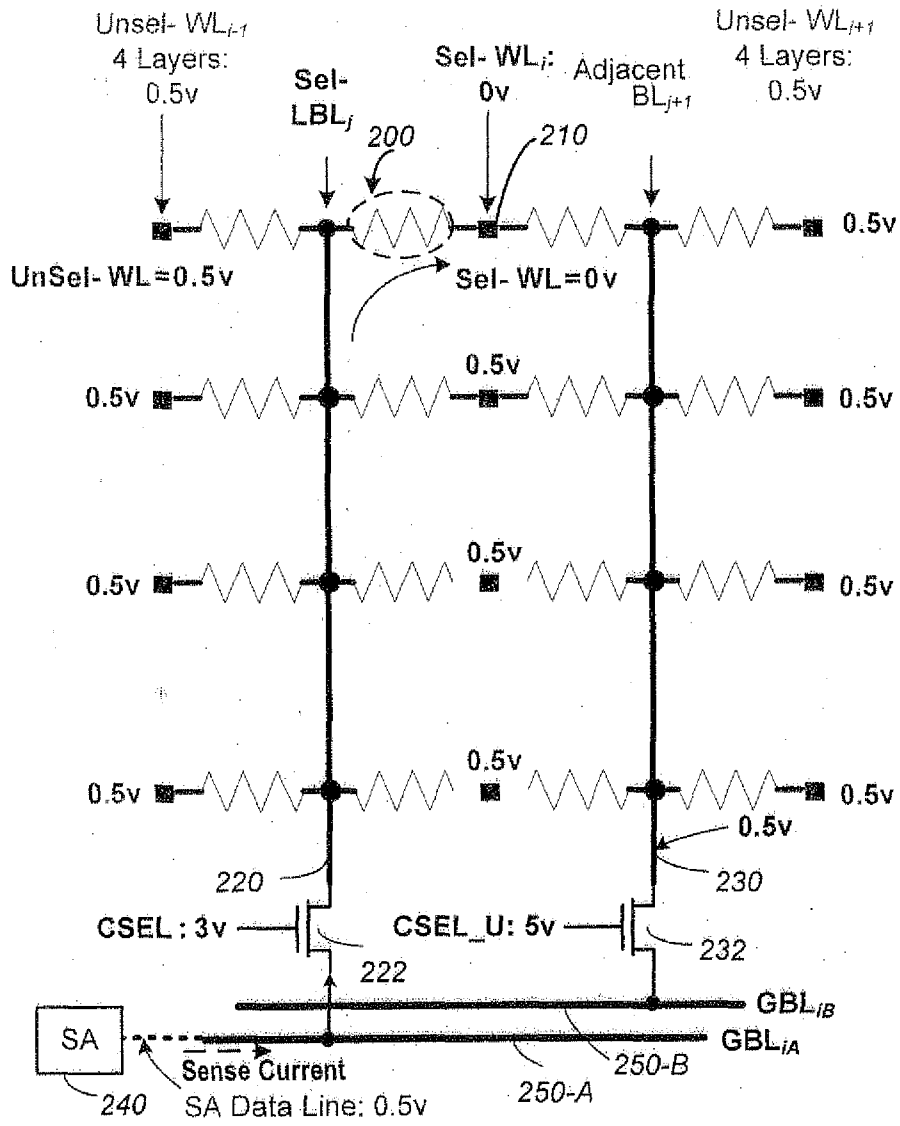

READ Bias Voltage and Leakage Current Flow
Double Global Bit line Structure

FIG. 18

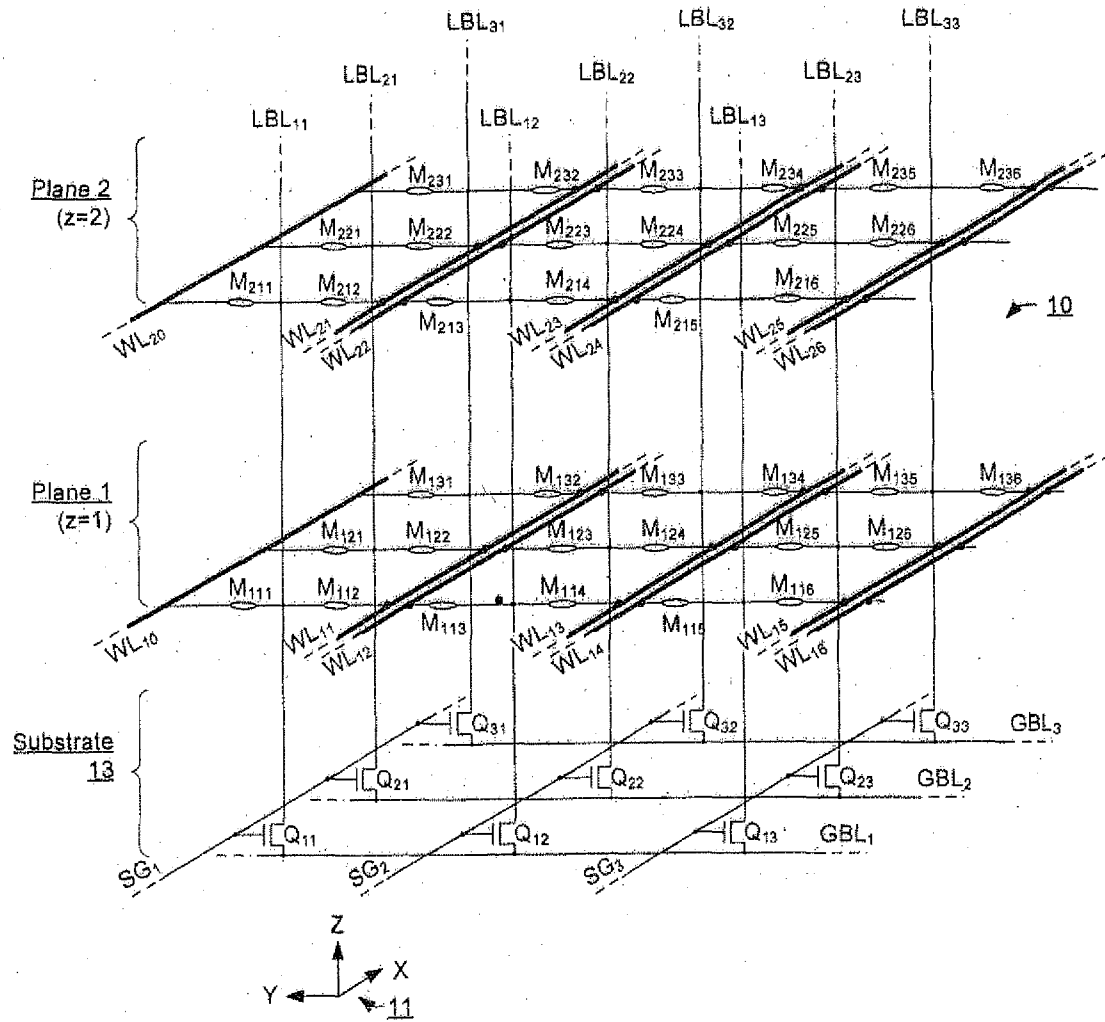

Single-Sided Word line Structure

FIG. 19

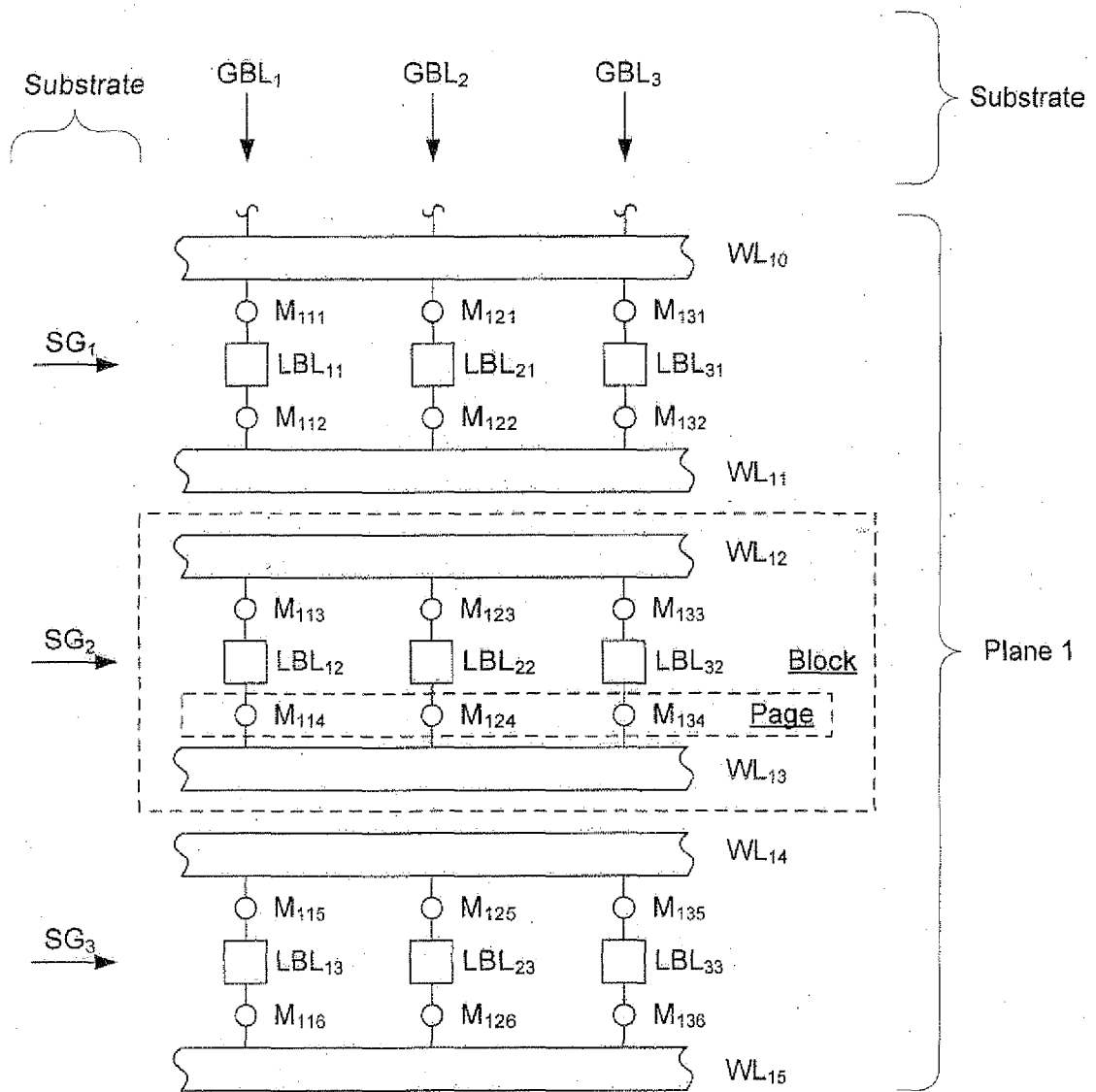

Single-Sided Word line Structure

FIG. 20

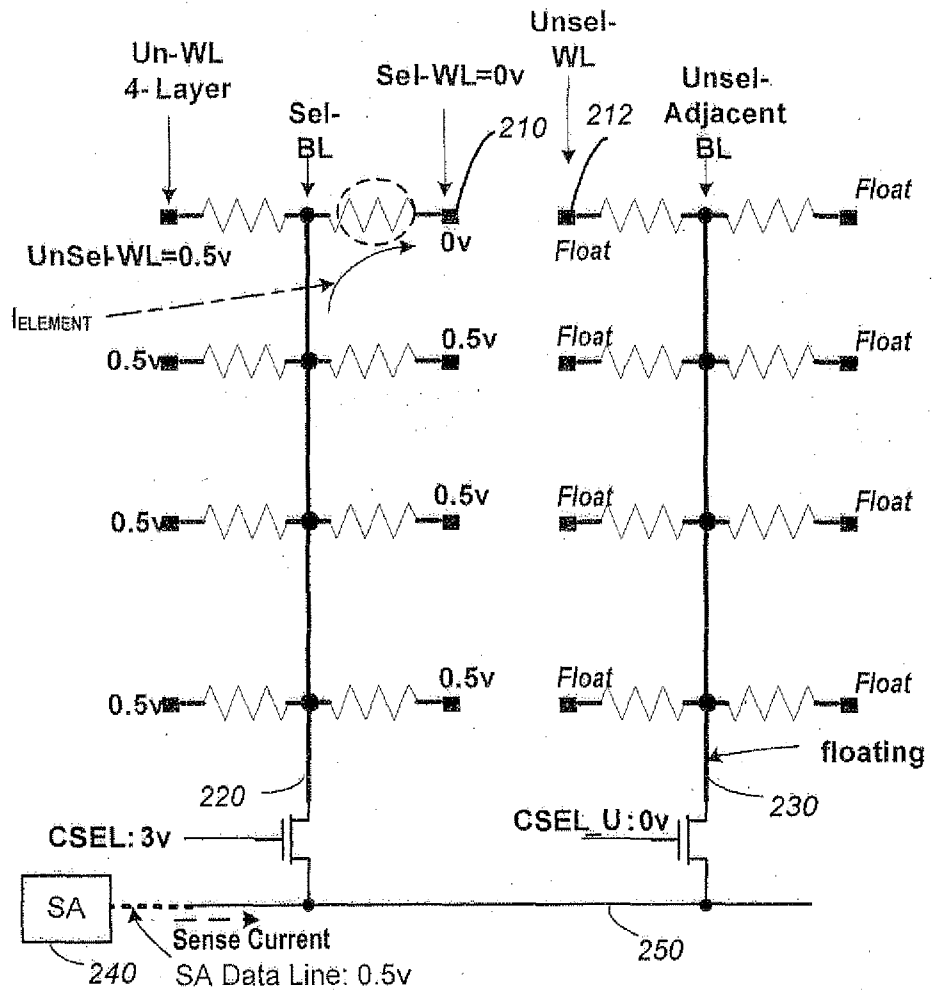

READ Bias Voltage and Leakage Current Flow

Single-Sided Word line Structure

FIG. 21

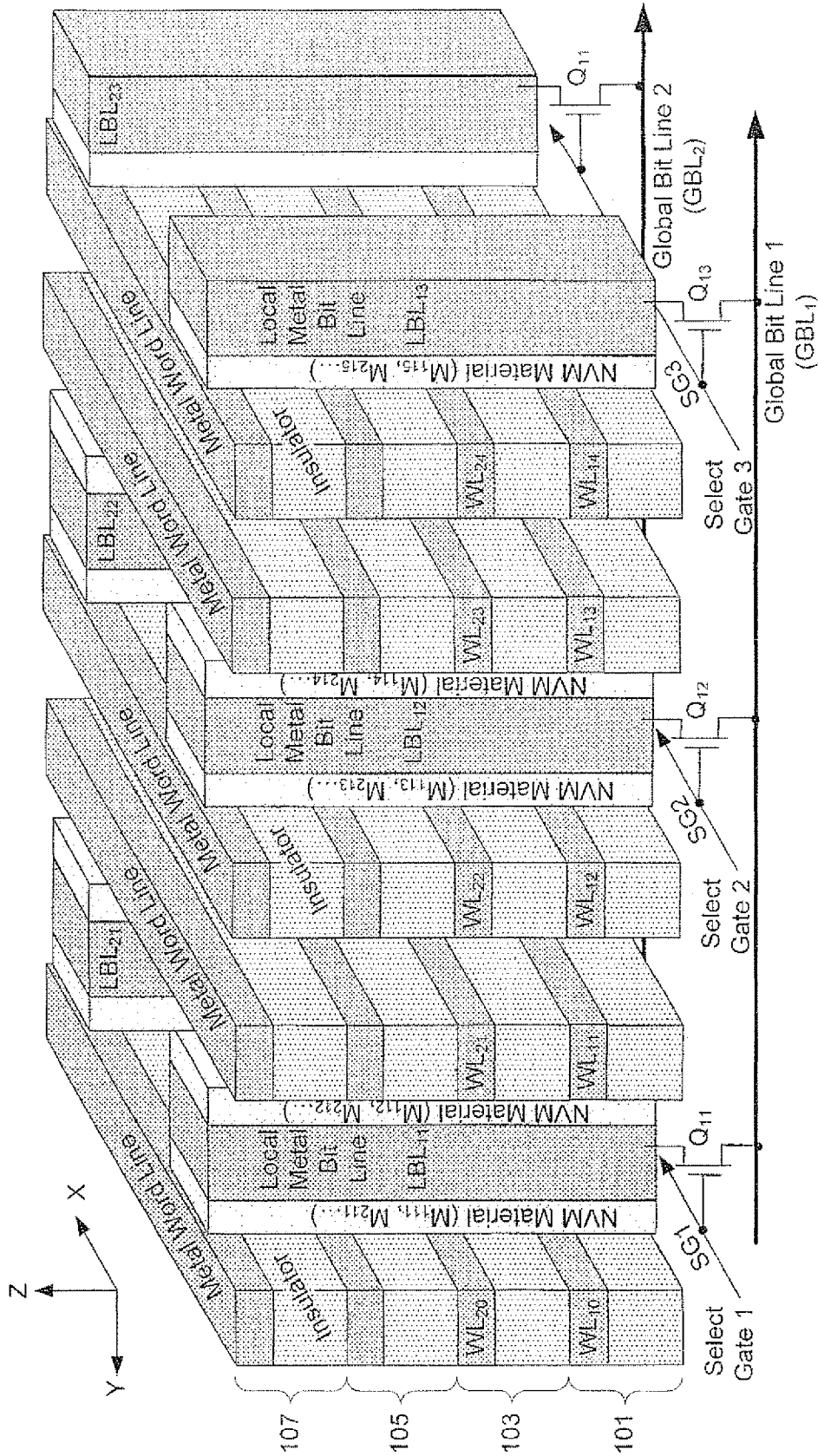

Single-Sided Word line Structure

FIG. 22

INTERNATIONAL SEARCH REPORT

International application No
PCT/US2010/029855

A. CLASSIFICATION OF SUBJECT MATTER

INV. G11C7/18 G11C13/00 H01L27/24
ADD.

According to International Patent Classification (IPC) or to both national classification and IPC

B. FIELDS SEARCHED

Minimum documentation searched (classification system followed by classification symbols)
G11C H01L

Documentation searched other than minimum documentation to the extent that such documents are included in the fields searched

Electronic data base consulted during the international search (name of data base and, where practical, search terms used)

EPO-Internal, COMPENDEX, INSPEC, IBM-TDB, WPI Data

C. DOCUMENTS CONSIDERED TO BE RELEVANT

Category*	Citation of document, with indication, where appropriate, of the relevant passages	Relevant to claim No.
Y	US 2008/175031 A1 (PARK JOON-MIN [KR] ET AL) 24 July 2008 (2008-07-24) paragraphs [0007] - [0009], [0130]; figures 4,6,9	1-18
Y	US 2005/045919 A1 (KAERIYAMA SHUNICHI [JP] ET AL) 3 March 2005 (2005-03-03) figure 17b	1-18
Y	US 7 339 812 B2 (MICRON TECHNOLOGIES INC [US] MICRON TECHNOLOGY INC [US]) 4 March 2008 (2008-03-04) figures 1-2	1-18
Y	US 5 894 437 A (PELLEGRINI GIANFRANCO [US]) 13 April 1999 (1999-04-13) * abstract; figure 1	1-18
	-/--	

Further documents are listed in the continuation of Box C.

See patent family annex.

* Special categories of cited documents :

- *A* document defining the general state of the art which is not considered to be of particular relevance
- *E* earlier document but published on or after the international filing date
- *L* document which may throw doubts on priority claim(s) or which is cited to establish the publication date of another citation or other special reason (as specified)
- *O* document referring to an oral disclosure, use, exhibition or other means
- *P* document published prior to the international filing date but later than the priority date claimed

- *T* later document published after the international filing date or priority date and not in conflict with the application but cited to understand the principle or theory underlying the invention
- *X* document of particular relevance; the claimed invention cannot be considered novel or cannot be considered to involve an inventive step when the document is taken alone
- *Y* document of particular relevance; the claimed invention cannot be considered to involve an inventive step when the document is combined with one or more other such documents, such combination being obvious to a person skilled in the art.
- *&* document member of the same patent family

Date of the actual completion of the international search

13 July 2010

Date of mailing of the international search report

21/07/2010

Name and mailing address of the ISA/

European Patent Office, P.B. 5818 Patentlaan 2
NL - 2280 HV Rijswijk
Tel. (+31-70) 340-2040,
Fax: (+31-70) 340-3016

Authorized officer

Havard, Corinne

INTERNATIONAL SEARCH REPORT

International application No
PCT/US2010/029855

C(Continuation). DOCUMENTS CONSIDERED TO BE RELEVANT

Category*	Citation of document, with indication, where appropriate, of the relevant passages	Relevant to claim No.
Y	US 2004/264244 A1 (SHARP KK [JP]) 30 December 2004 (2004-12-30) figures 18-19 -----	18

INTERNATIONAL SEARCH REPORT

Information on patent family members

International application No

PCT/US2010/029855

Patent document cited in search report	Publication date	Patent family member(s)	Publication date
US 2008175031 A1	24-07-2008	KR 20080069313 A	28-07-2008
US 2005045919 A1	03-03-2005	JP 4356542 B2 JP 2005101535 A US 2009001348 A1	04-11-2009 14-04-2005 01-01-2009
US 7339812 B2	04-03-2008	AU 2003243244 A1 TW 281165 B WO 03098636 A2 US 2005226041 A1	02-12-2003 11-05-2007 27-11-2003 13-10-2005
US 5894437 A	13-04-1999	NONE	
US 2004264244 A1	30-12-2004	CN 1574076 A DE 602004008833 T2 EP 1486985 A2 JP 4113493 B2 JP 2005025914 A KR 20040107435 A TW 237271 B	02-02-2005 12-06-2008 15-12-2004 09-07-2008 27-01-2005 20-12-2004 01-08-2005