



(12) **EUROPEAN PATENT APPLICATION**

(88) Date of publication A3:
23.10.2002 Bulletin 2002/43

(51) Int Cl.7: **B25B 27/06**

(43) Date of publication A2:
30.12.1998 Bulletin 1998/53

(21) Application number: **98305006.3**

(22) Date of filing: **25.06.1998**

(84) Designated Contracting States:
**AT BE CH CY DE DK ES FI FR GB GR IE IT LI LU
MC NL PT SE**
Designated Extension States:
AL LT LV MK RO SI

(72) Inventors:
• **Kury's, Mark Roberts**
Deeping St. James, Lincolnshire PE6 8SW (GB)
• **Cowling, Gary David**
Whittlesey, Peterborough PE7 2RH (GB)

(30) Priority: **26.06.1997 GB 9713372**

(74) Representative: **Waters, Jeffrey**
Marconi Intellectual Property
Marrable House
The Vineyards
Gt. Baddow
Chelmsford Essex CM2 7QS (GB)

(71) Applicant: **General Domestic Appliances Limited**
Peterborough PE2 9JB (GB)

(54) **A tool for, and a method of, removal of a bearing from a bearing housing**

(57) A bearing 2 is removed from a bearing housing 4 of a laundry appliance drum 1 by driving axially an annular thrust region e.g. sleeve 17, against an end face of the bearing. This is effected by rotation of an internally threaded member, such as member 18, relative to an externally threaded member e.g. bolt 16. One of the threaded members, in this case member 18, has anti-

rotation means 19 to prevent rotation of member 18 relative to the bearing housing so that the bearing can be removed by rotary force being applied only to the bolt 16 by means of say a T-bar 27. The invention permits bearings to be removed by applying rotary force only to one of the members. Previously, rotary force had to be applied to both members, in opposite directions.

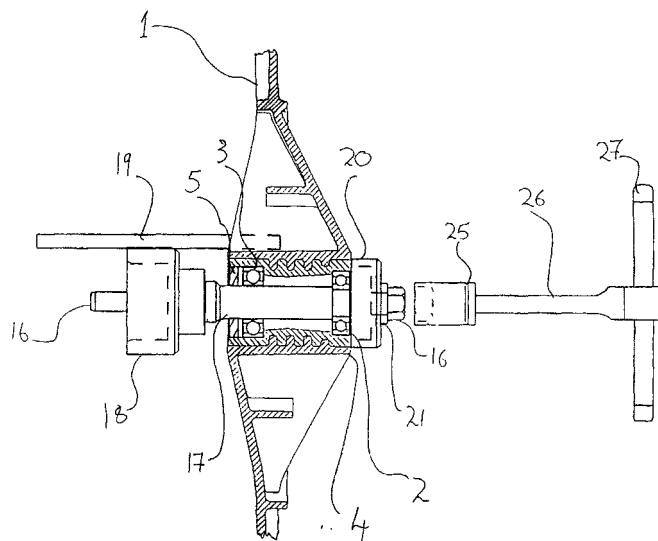

Fig. 5



European Patent
Office

EUROPEAN SEARCH REPORT

Application Number
EP 98 30 5006

DOCUMENTS CONSIDERED TO BE RELEVANT			
Category	Citation of document with indication, where appropriate, of relevant passages	Relevant to claim	CLASSIFICATION OF THE APPLICATION (Int.Cl.6)
X	US 2 036 782 A (ANDRE ULLMO) 7 April 1936 (1936-04-07)	1,3-11	B25B27/06
A	* the whole document *	2	
X	US 5 226 208 A (GRACEY THOMAS) 13 July 1993 (1993-07-13)	1-5,8-10	
A	* figure 1 *	6,7,11	
X	US 4 724 608 A (PARROTT RONALD J W) 16 February 1988 (1988-02-16)	1,3-5, 8-10	
A	* column 5, line 8-12; claim 1; figure 1 *	2,6,7,11	
A	DE 919 939 C (FRITZ MOENNICH) 8 November 1954 (1954-11-08)	1-11	
A	* the whole document *		
A	US 4 694 569 A (COLVELL WILLIAM F ET AL) 22 September 1987 (1987-09-22)	1-11	
A	* the whole document *		
The present search report has been drawn up for all claims			TECHNICAL FIELDS SEARCHED (Int.Cl.6)
			B25B
Place of search	Date of completion of the search	Examiner	
THE HAGUE	2 September 2002	Jaeger, H	
CATEGORY OF CITED DOCUMENTS			
X : particularly relevant if taken alone Y : particularly relevant if combined with another document of the same category A : technological background O : non-written disclosure P : intermediate document		T : theory or principle underlying the invention E : earlier patent document, but published on, or after the filing date D : document cited in the application L : document cited for other reasons & : member of the same patent family, corresponding document	

EPO FORM 1503 03/02 (P04C01)

**ANNEX TO THE EUROPEAN SEARCH REPORT
ON EUROPEAN PATENT APPLICATION NO.**

EP 98 30 5006

This annex lists the patent family members relating to the patent documents cited in the above-mentioned European search report. The members are as contained in the European Patent Office EDP file on
The European Patent Office is in no way liable for these particulars which are merely given for the purpose of information.

02-09-2002

Patent document cited in search report		Publication date	Patent family member(s)	Publication date
US 2036782	A	07-04-1936	NONE	
US 5226208	A	13-07-1993	NONE	
US 4724608	A	16-02-1988	NONE	
DE 919939	C	08-11-1954	NONE	
US 4694569	A	22-09-1987	NONE	

EPO FORM P0459

For more details about this annex : see Official Journal of the European Patent Office, No. 12/82