



INTERNATIONAL APPLICATION PUBLISHED UNDER THE PATENT COOPERATION TREATY (PCT)

<p>(51) International Patent Classification ⁶ : A61F 2/06</p>	<p>A1</p>	<p>(11) International Publication Number: WO 99/04728 (43) International Publication Date: 4 February 1999 (04.02.99)</p>
<p>(21) International Application Number: PCT/US98/09800 (22) International Filing Date: 23 July 1998 (23.07.98) (30) Priority Data: 08/898,997 24 July 1997 (24.07.97) US (71) Applicant: MEDTRONIC, INC. [US/US]; 7000 Central Avenue N.E., Minneapolis, MN 55432-3576 (US). (72) Inventors: OLSON, Steve, L.; 10388 Byrne Avenue, Cupertino, CA 95014 (US). DAVIS, Glenn, R.; 1330 Cordilleras Avenue, Sunnyvale, CA 94087 (US). (74) Agents: BARRISH, Mark, D. et al.; Townsend and Townsend and Crew LLP, 8th floor, Two Embarcadero Center, San Francisco, CA 94111-3834 (US).</p>		<p>(81) Designated States: JP, European patent (AT, BE, CH, CY, DE, DK, ES, FI, FR, GB, GR, IE, IT, LU, MC, NL, PT, SE). Published <i>With international search report.</i></p>

(54) Title: DISPOSABLE DELIVERY DEVICE FOR ENDOLUMINAL PROSTHESES

(57) Abstract

Improved systems, devices, and methods for deployment of endoluminal prostheses within the lumens of the body withdraw a sheath from over the tightly compressed prostheses using an actuation mechanism having a variable mechanical advantage. This allows movement of the sheath to be initiated with ease and accuracy. Once deployment is safely underway, and after static frictional forces have been overcome, the remainder of the deployment may proceed more rapidly without significantly degrading overall safety or ease of use of the delivery system. In another improvement, the handle for the actuation mechanism may rotate about an axis parallel to the axis of the sheath. An outer tube may be provided around the sheath and coupled to the prosthesis restraining member within the sheath. The outer tube may be inserted through an introducer valve, so that friction between the outer tube and introducer valve helps restrain the prosthesis as the sheath is withdrawn proximally relative to both the member and the outer tube.

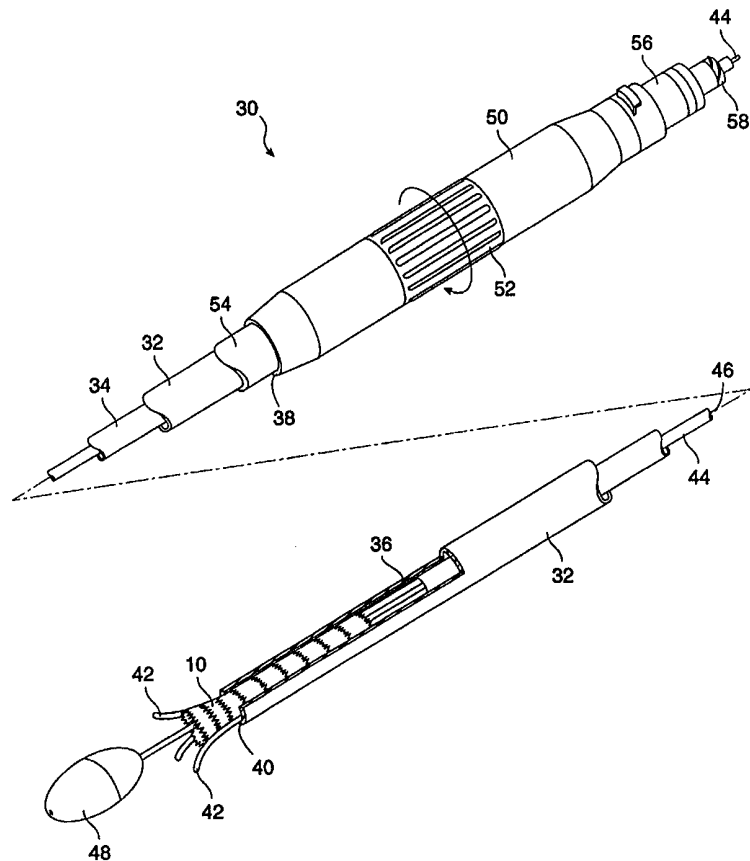

FOR THE PURPOSES OF INFORMATION ONLY

Codes used to identify States party to the PCT on the front pages of pamphlets publishing international applications under the PCT.

AL	Albania	ES	Spain	LS	Lesotho	SI	Slovenia
AM	Armenia	FI	Finland	LT	Lithuania	SK	Slovakia
AT	Austria	FR	France	LU	Luxembourg	SN	Senegal
AU	Australia	GA	Gabon	LV	Latvia	SZ	Swaziland
AZ	Azerbaijan	GB	United Kingdom	MC	Monaco	TD	Chad
BA	Bosnia and Herzegovina	GE	Georgia	MD	Republic of Moldova	TG	Togo
BB	Barbados	GH	Ghana	MG	Madagascar	TJ	Tajikistan
BE	Belgium	GN	Guinea	MK	The former Yugoslav Republic of Macedonia	TM	Turkmenistan
BF	Burkina Faso	GR	Greece	ML	Mali	TR	Turkey
BG	Bulgaria	HU	Hungary	MN	Mongolia	TT	Trinidad and Tobago
BJ	Benin	IE	Ireland	MR	Mauritania	UA	Ukraine
BR	Brazil	IL	Israel	MW	Malawi	UG	Uganda
BY	Belarus	IS	Iceland	MX	Mexico	US	United States of America
CA	Canada	IT	Italy	NE	Niger	UZ	Uzbekistan
CF	Central African Republic	JP	Japan	NL	Netherlands	VN	Viet Nam
CG	Congo	KE	Kenya	NO	Norway	YU	Yugoslavia
CH	Switzerland	KG	Kyrgyzstan	NZ	New Zealand	ZW	Zimbabwe
CI	Côte d'Ivoire	KP	Democratic People's Republic of Korea	PL	Poland		
CM	Cameroon	KR	Republic of Korea	PT	Portugal		
CN	China	KZ	Kazakstan	RO	Romania		
CU	Cuba	LC	Saint Lucia	RU	Russian Federation		
CZ	Czech Republic	LI	Liechtenstein	SD	Sudan		
DE	Germany	LK	Sri Lanka	SE	Sweden		
DK	Denmark	LR	Liberia	SG	Singapore		
EE	Estonia						

DISPOSABLE DELIVERY DEVICE FOR ENDOLUMINAL PROSTHESES

BACKGROUND OF THE INVENTION

1. Field of the Invention

The present invention generally relates to tubular endoluminal prostheses, such as stents, stent-grafts, and the like. More particularly, the present invention provides improved delivery systems and methods for their use to accurately and safely deploy endoluminal prostheses within the lumens of the body, particularly within the vascular system for treatment of aortic aneurysms, stenoses, and the like.

Vascular aneurysms are the result of abnormal dilation of a blood vessel, usually resulting from disease and/or genetic predisposition, which can weaken the arterial wall and allow it to expand. While aneurysms can occur in any blood vessel, most occur in the aorta and peripheral arteries, with the majority of aortic aneurysms occurring in the abdominal aorta, usually beginning below the renal arteries and often extending into one or both of the iliac arteries.

Aortic aneurysms are now commonly treated in open surgical procedures where the diseased vessel segment is bypassed and repaired with an artificial vascular graft. While considered to be an effective surgical technique, particularly considering the alternative of a usual fatal ruptured abdominal aortic aneurysm, conventional vascular graft surgery suffers from a number of disadvantages. The surgical procedure is complex and requires experienced surgeons and well-equipped surgical facilities. Even with the best surgeons and equipment, however, patients being treated frequently are elderly and weakened from cardiovascular and other diseases, reducing the number of eligible patients. Even for eligible patients prior to rupture, conventional

aneurysm repair has a relatively high mortality rate, usually from 2% to 10%. Morbidity related to the conventional surgery includes myocardial infarction, renal failure, impotence, paralysis, and other conditions. Additionally, even with
5 successful surgery, recovery takes several weeks, and often requires a lengthy hospital stay.

In order to overcome some or all of these drawbacks, endovascular prosthesis placement for the treatment of aneurysms has been proposed. Although very promising, many of
10 the proposed methods and apparatus suffer from undesirable limitations. In particular, accurate delivery and placement of the endovascular prosthesis within the vasculature can be problematic.

Stent-grafts are often resilient structures, biased
15 to expand against the surrounding luminal wall. Such resiliently-expanding stent-grafts are tightly compressed within the catheter, imposing significant forces against the surrounding catheter sheath. This can often lead to excess friction between the stent-graft and the sheath, particularly
20 when the resiliently-expanding structure invaginates into the catheter material. As these catheters are often required to maneuver within the tortuous vascular system, catheter sheaths are often formed as flexible, elongate bodies which are particularly susceptible to vagination of the tightly
25 compressed stent-graft in the flexible material of the catheter wall.

For these reasons, it would be desirable to provide improved devices, systems, and methods for endoluminal
30 deployment of prostheses such as stents, stent-grafts, and the like, for treatment of aneurysms and other diseases of the body lumens. It would be particularly desirable if such improved systems and methods enhanced the accuracy and safety of the deployment procedure, without significantly increasing deployment time, equipment costs, or complexity of the
35 deployment procedure.

2. Description of the Background Art

Devices for endoluminal placement of prostheses are described in U.S. Patent Nos. 4,512,338, 4,651,738, 4,665,918, 5,458,615, 5,480,423, 5,484,418, 5,489,295, 4,990,151, 5,035,706, 5,433,723, 5,443,477, 5,282,824, 5,275,622, 5,242,399, 5,201,757, 5,190,058, 5,104,399, 5,092,877, 4,990,151, and EP Patent Publication Nos. EP 0 539 237 A1, 0 518 839 A2, EP 0 505 686 A1, and EP 0 508 473 A2.

10 SUMMARY OF THE INVENTION

The present invention provides improved systems, devices, and methods for deployment of endoluminal prostheses within the lumens of the body, and particularly for deployment of stents and stent-grafts within the vascular system. In a first improvement over known delivery systems, a sheath is withdrawn from over a tightly compressed prostheses using an actuation mechanism having a variable mechanical advantage, which varies with the position of the sheath. This allows movement of the sheath to be initiated with ease and accuracy. Once deployment is safely underway, and after static frictional forces have been overcome, the remainder of the deployment may proceed more rapidly, without significantly degrading overall safety or ease of use. In another improvement, the handle for the actuation mechanism may rotate about an axis parallel to the axis of the sheath, thereby avoiding any inadvertent proximal and distal movement imparted by the handle to the prosthesis or delivery system. Accuracy and ease of use of the delivery system may also be improved by providing an outer tube around the sheath which is coupled to the prosthesis restraining member within the sheath. The outer tube may be inserted through an introducer valve, so that friction between the outer tube and introducer valve helps restrain the prosthesis at the target position as the sheath is withdrawn proximally.

In a first aspect, the present invention provides a delivery system for use with a tubular endoluminal prosthesis. The delivery system comprises a sheath having a proximal end,

and a distal end, and a lumen. The lumen is capable of receiving the prosthesis near the distal end. The member in the lumen of the sheath is adapted for expelling the prosthesis from the lumen as the sheath moves from a first position to a second position relative to the member. An actuation mechanism is attached to the member, and couples a handle to the sheath with a mechanical advantage that varies as the sheath moves between the first position and the second position.

Generally, a displacement of the handle effects a first displacement of the sheath relative to the member when the sheath is adjacent the first position. This same handle displacement effects a significantly greater displacement of the sheath relative to the member when the sheath is adjacent to the second position. Typically, the initial mechanical advantage is larger to overcome static frictional forces between the prosthesis and the sheath, allowing the sheath to be withdrawn slowly and precisely. Once the sheath has begun sliding over the prosthesis, and in some embodiments, once an end of the prosthesis has expanded to engage the surrounding luminal wall, the deployment may proceed at a more rapid rate by using a lower mechanical advantage.

In another aspect, the present invention provides a prosthetic delivery system for use with a radially expandable tubular endoluminal prosthesis. The delivery system comprises a sheath having a proximal end, a distal end, an axis therebetween, and a lumen capable of receiving the prosthesis near the distal end. A member is disposed in the lumen for expelling the prosthesis from the lumen as the sheath moves from a first position to a second position relative to the member. An actuation mechanism is attached to the member, and couples the sheath to a handle. The handle is rotatable about an axis substantially parallel to the axis of the sheath to effect movement of the sheath from the first position to the second position.

In another aspect, the invention provides a delivery system for inserting a tubular endoluminal prosthesis into a patient body. The delivery system comprises a sheath having a

proximal end, a distal end, and a lumen capable of receiving the prosthesis near the distal end. A member is disposed in the lumen, and is adapted for expelling the prosthesis from the lumen as the sheath moves from a first position to a second position relative to the member. An outer tube is disposed over the sheath. A housing is attached to the member near the proximal end of the sheath, and is coupled to the outer tube so that the outer tube remains substantially axially aligned with the member when the sheath moves from the first position to the second position. The outer tube will often be insertable into an introducer valve, so that friction between the outer tube and the introducer valve will help hold the prosthesis at the target location during deployment.

In a method according to the present invention, a radially expandable tubular endoluminal prosthesis is positioned at a target location in a body lumen within a lumen of a sheath. The prosthesis is released from the sheath by actuating a handle. This withdraws the sheath proximally from a first position to a second position. A displacement of the handle effects a first displacement of the sheath when the sheath is adjacent to the first position. The same handle displacement effects a second displacement of the sheath which is different than the first sheath displacement when the sheath is adjacent to the second position.

In another method provided by the present invention, a radially expandable tubular endoluminal prosthesis is deployed by positioning the prosthesis at a target location in a body lumen while the prosthesis is disposed within a lumen of a sheath. The prosthesis is released from the sheath by rotating a handle. The handle rotates about an axis which is parallel to an axis of the sheath, and moves the sheath axially from over the prosthesis.

In yet another method of the present invention, a radially expandable tubular endoluminal prosthesis is deployed by inserting the prosthesis into the body lumen through an introducer valve. The prosthesis is inserted while disposed within a lumen of a sheath. An outer tube is also inserted through an introducer valve, and the prosthesis is positioned

at a target location in the body lumen. The prosthesis is released from the sheath by withdrawing the sheath and restraining the prosthesis with a member disposed in the sheath. This member is axially restrained relative to the outer tube while releasing the prosthesis, so that friction between the introducer valve and the outer tube helps prevent movement of the prosthesis from the target location.

BRIEF DESCRIPTION OF THE DRAWINGS

Fig. 1 is a simplified side view of an exemplary cylindrical vascular stent-graft.

Fig. 2 is a perspective view of a delivery system according to the principles of the present invention.

Fig. 3 illustrates an exemplary modular endoluminal bifurcated prosthesis.

Fig. 4 illustrates a method for using the delivery system of Fig. 2 for deploying a bifurcated prosthetic module.

Fig. 5 illustrates an outer tube for use in the delivery system of Fig. 2 to provide a low-friction seal between an introducer valve and the delivery sheath.

Fig. 6 illustrates a method for using the outer tube between the delivery sheath and an introducer valve to prevent movement of the prosthesis during deployment.

Fig. 7 illustrates an alternative delivery system which prevents relative motion between the introducer valve and the prosthesis with an external support rod.

Fig. 8 is a cross-sectional view showing the actuation mechanism of the deployment system of Fig. 2.

Fig. 9 is an exploded view showing the components of the actuation mechanism of Fig. 8.

Figs. 10 and 11 are a cross-sectional view and a side view, respectively, of an alternative deployment system having an actuation mechanism including threads which vary in pitch.

Fig. 12 illustrates a mandrel for forming variable pitch threads for use in the deployment system of Fig. 10.

Fig. 13 is a cross-sectional view through the actuation handle of the deployment system of Fig. 10.

Figs. 14 through 17 illustrate components of the actuation system for use in the deployment systems of Figs. 2 and 10.

DESCRIPTION OF THE PREFERRED EMBODIMENT

The present invention provides delivery devices, systems, and methods for delivering radially expandable tubular prostheses, particularly stents, stent-grafts, and the like. The delivery structures and methods of the present invention are suitable for a wide variety of therapeutic uses, including stenting of the ureter, urethra, trachea, bronchi, esophagus, biliary tract, and the like. The structures and methods will also be useful for creating temporary or long-term lumens, such as for the formation of fistulas. The present invention will find its most immediate application for delivery of endovascular prostheses as a treatment for diseases of the vasculature, particularly for treating aneurysms, stenoses, and the like.

The structures and methods described hereinbelow will find use in deployment of axially uniform cylindrical prostheses, of pre-assembled bifurcated prostheses, and of prosthetic modules for selective assembly, either prior to deployment or *in situ*. Modular prosthetic structures and delivery methods are more fully described in co-pending U.S. Patent Application Nos. 08/704,960, filed August 29, 1996 (Attorney Docket No. 16380-003410); 08/538,706, filed October 3, 1995 (Attorney Docket No. 16380-003800); and 60/028,928, filed October 7, 1996 (Attorney Docket No. 16380-004110), the full disclosures of which are incorporated herein by reference.

Referring now to Fig. 1, an exemplary cylindrical prosthesis 10 comprises a preferred tubular frame 12 formed as a plurality of independent ring frames 14. Tubular frame 12 supports an inner liner 18. Optionally, an outer liner is

disposed over the ring frames, either inside of inner liner 18, or in combination therewith.

To secure ring frames 14 to liner 18, the liner is typically sutured to the frame. A wide variety of alternative
5 liner/frame attachment mechanisms are available, including adhesive bonding, heat welding, ultrasonic welding, and the like. Preferably, liner 18 is sutured along the extreme proximal and distal ends of frame 12 to enhance sealing between the liner and the surrounding body lumen.

10 Prosthesis 10 will typically have a length in the range from about 20 mm to 500 mm, preferably being 50 mm to 200 mm. A relaxed diameter of prosthesis 10 will generally be in the range from about 4 mm to 45 mm, preferably being in the range from about 5 mm to 38 mm.

15 Referring now to Fig. 2, an exemplary delivery system 30 comprises a tubular sheath 32 and a shaft 34. Sheath 32 has a lumen 36 extending from a proximal end 38 to a distal end 40. Shaft 34 is slidably received within lumen 36, and a plurality of runners 42 extend distally from the shaft.
20 Runners 42 line a portion of the inner surface of lumen 36, and slide within the lumen of the shaft. Shaft 34 also has a lumen, in which a core shaft 44 is affixed. Core shaft 44 has a guidewire lumen 46. Nosecone 48 is affixed to the distal end of core shaft 44, and can therefore be manipulated with
25 the runners. Alternatively, core shaft 44 may be slidably disposed within shaft 34 to allow independent manipulation of nosecone 48.

Prosthesis 10 is radially compressed and restrained within runners 42. In turn, sheath 32 prevents runners 42
30 from expanding outwardly. Runners 42 are preferably formed from a hard material, and distribute the expansive load from the frame of prosthesis 10 over the inner surface of lumen 36. Exemplary methods and devices for deploying prostheses using runners 42 are more fully described in co-pending U.S. Patent
35 Application Serial No. 08/475,200, filed June 7, 1995 (Attorney Docket No. 16380-001130), the full disclosure of which is incorporated herein by reference.

A housing 50 is disposed at proximal end 38 of sheath 32. Housing 50 contains an actuation mechanism for withdrawing sheath 32 proximally while prosthesis 10 is axially restrained by runners 42 and shaft 34. To withdraw sheath 32 proximally, a handle 52 is rotated about the axis of the sheath, as illustrated. This avoids inadvertently imparting any axial movement of the delivery system from rotation of the handle during deployment, preventing prosthesis 10 from being displaced axially from the target location, and also avoiding any injury of the surrounding body lumen by inadvertently advancing runners 42.

An outer tube 54 extends distally from housing 50 over sheath 32. Shaft 34 extends through housing 50 and is affixed to a connector 56, which is releasably attached to the proximal end of housing 50. Thus, shaft 34 and outer tube 54 are coupled together through the housing, so that sheath 32 retracts proximally between these two structures when handle 52 rotates. Once the prosthesis is deployed and runners 42 slide proximally from between the prosthesis and surrounding body lumen, connector 56 may be uncoupled from housing 50 to draw runners 42 and the proximal portion of nose-cone 48 back into the distal end of sheath 32.

A luer fitting 58 is affixed to the proximal end of connector 56 to facilitate introducing a guidewire into guidewire lumen 46 of core shaft 44, or to allow the guidewire lumen to be sealed when not in use.

Referring now to Fig. 3, an assembled branching endovascular prosthesis 60 comprises a relatively rigid lumen separation portion 62 between a trunk portion 64 and two branch portions 68. Lumen separation portion 62 may include a contiguous frame to provide relatively high column and hoop strength, while the branch end trunk portions may be formed with independent ring frames or a helical frame in which the loops are separated to enhance axial flexibility. Sealing cuffs 66 and 70 securely anchor the prosthesis against healthy tissue, and also seal the prosthetic lumen against the surrounding endolithium of the blood vessel.

As schematically illustrated in Fig. 4, a bifurcated prosthetic module of bifurcated prosthesis 60 may be deployed using delivery system 30 to isolate an abdominal aortic aneurysm AAA. This initial prosthetic module extends from the abdominal aorta AA to a first iliac I, and has an open port 72 for receiving a cylindrical prosthetic module to effectively seal the distended aneurysm from the blood flow. The prosthetic module is deployed by axially restraining the module within runners 42 and withdrawing sheath 32 proximally. The runners, which typically comprise thin strips of a high-strength metal such as stainless steel, slide along the inner lumen of sheath 32 and flex outwardly as the prosthesis expands resiliently. Once the prosthetic module is fully expanded, the runners can be withdrawn proximally from between the prosthesis and the surrounding luminal wall, while the expanded prosthesis engages the luminal wall between the runners.

The bifurcated prosthetic module illustrated in Fig. 4 includes a pattern of discreet radiopaque markers 74 to facilitate positioning and assembly of the prosthetic modules fluoroscopically. The use and structure such radio-opaque markers is more fully described in co-pending U.S. Patent Application Serial Nos. 08/628,797, filed April 5, 1996 (Attorney Docket No. 16380-005600) and _____, filed June 17, 1997 (Attorney Docket No. 16380-005710), the full disclosures of which are incorporated herein by reference.

Referring now to Fig. 5, outer tube 54 generally comprises a tubular body 76 and an endcap 78. An o-ring 80 is disposed within endcap 78, and provides a low friction hemostasis seal around the outer surface of sheath 32. As described above, the runners of the present invention facilitate smoothly retracting sheath 32 relative to the radially compressed prosthesis. However, a substantial amount of friction may be encountered between the outer surface of delivery system 30 and introducer sheath 82 at which the delivery system enters a patient's body 84.

Introducer sheaths generally provide hemostasis around catheters, guidewires, other invasive surgical

implements of various sizes and configurations. Such
introducer sheaths typically include a resilient sealing body
which radially engages the outermost layer of the delivery
system. As it is generally desirably to leave the internal
5 prosthesis at a fixed position while withdrawing sheath 32
proximally, such friction between introducer valve 82 and
sheath 32 is generally disadvantageous. However, by coupling
outer tube 54 to housing 50, as illustrated in Fig. 6, and by
providing an actuation mechanism which withdraws sheath 32
10 relative to shaft 34 and housing 50, friction between outer
tube 54 and introducer valve 82 may be used to help restrain
the prosthesis at the target location during deployment.

To facilitate insertion of outer tube 54 into
introducer valve 82, a distal end of tubular body 76 may be
15 tapered. In some embodiments, introducer valve 82 may be
actuated once outer tube 54 and the prosthesis are positioned,
compressing the sealing body against the outer tube to lock
the prosthesis in place. A particularly advantageous
actuatable introducer valve is described in co-pending U.S.
20 Patent Application No. 08/744,659, filed November 6, 1996
(Attorney Docket No. 16380-006300), the full disclosure of
which is incorporated herein by reference.

An alternative system and method for maintaining the
position of the prosthesis within patient body 84 is
25 illustrated in Fig. 7. In this embodiment, the actuation
mechanism for withdrawing sheath 32 relative to shaft 34 is
contained in a removable actuation housing 86. Housing 86 is
coupled to introducer valve 82 using a brace rod 88. Although
housing 86 and the actuation mechanism therein may be reused
30 for several deployment procedures, the cost of such a system
is generally higher than the delivery system illustrated in
Fig. 2, particularly when repeated sterilization of the
housing and actuation mechanism are considered. Additionally,
the use of an actuation handle which rotates perpendicularly
35 to the axis of sheath 32 may lead to inadvertent axial
movement of the prosthesis during deployment. This can be
particularly problematic when runners 42 are exposed about the
perimeter of the body lumen, as any distal advancement of the

runners may lead to injury or penetration through the luminal wall.

An actuation mechanism 90 which converts the axial rotation of handle 52 to axial translation of sheath 54 can be understood with reference to Figs. 8 and 9. Handle 52 comprises a tubular structure having internal threads 92. Housing 50 includes a distal housing portion 94 and a proximal housing portion 96. These housing portions are held together by a slotted tube 98 extending axially within the threaded handle.

A slider 100 is affixed to the proximal end of sheath 32. Slider 100 includes a threaded ring 102 encircling slotted tube 98, and an inner body 104 which rides within the slotted tube. Threaded ring 102 is affixed to inner body 104 by set screws, tabs protruding radially from the inner body, tabs protruding radially inwardly from the thread ring, or the like. Regardless, some structure of slider 100 extends radially through the slots of slotted tube 98, so that the slotted tube rotationally restrains slider 100.

A reinforcing rod 106 extends distally from proximal portion 96 of housing 50. Reinforcing tube 106 extends through slider 100 to near the distal end of housing 50, and is slidably received in the lumen of sheath 32. Connector 56 is couplable to a proximal fitting 108. Connector 56 is affixed to shaft 34, so that housing 50 maintains axial alignment between outer tube 54 and shaft 34 when the connector 56 is attached to proximal fitting 108. Reinforcing tube 106 prevents buckling of shaft 34 as slider 100 moves proximally.

Sheath 32 is withdrawn proximally by rotating handle 52 relative to housing 50. As threaded ring 102 of slider 100 engages internal threads 92 of handle 52, and as slotted tube 98 rotationally restrains slider 100 within housing 50, rotation of the handle pulls the slider and attached graft cover axially as shown. In this embodiment, internal threads 92 are constant along the length of handle 52, so that a particular displacement of the handle relative to the housing will effect a consistent axial displacement of the slider

regardless of the slider's position. Such constant internal threads will generally have a pitch of between about 0.125 and 0.250, providing a total mechanical advantage in a range from about 4:1 to 3:1 between handle 52 and sheath 32. As will be described hereinbelow, the threads will often have two or more leads, so that the distance between adjacent threads may be 1/2 (or less) the thread pitch.

A variable displacement delivery system 110 is illustrated in Figs. 10 and 11. Variable pitch delivery system 110 includes many of the same components described above, but makes use of a handle 112 having variable pitch internal threads 114. Variable threads 114 have a relatively small pitch adjacent the distal end of handle 112 so that each rotation of the handle moves sheath 32 proximally a relatively small axial distance during the initial phases of deployment. This provides an increased mechanical advantage between the handle and the sheath, helping the physician to overcome the large static frictional forces between the prosthesis and the surrounding sheath. This enhanced mechanical advantage also helps overcome any invagination of the prosthetic frame into the surrounding sheath material. As a result, the distal end of the prosthesis (which is deployed first) will be very gradually released, allowing the physician to verify the accuracy of the deployment position as the prosthesis initially engages the surrounding body lumen. These distal threads will generally have a pitch of between about 0.125 and 0.375, providing a mechanical advantage in the range from about 4:1 to about 2.5:1.

While it is possible to use a constant thread delivery system having a relatively small pitch, this requires repeated rotation of the handle for a considerable amount of time. Additionally, frictional forces between the prosthesis and surrounding sheath decrease once the static frictional forces have been overcome and the sheath begins to move, as dynamic frictional forces are typically lower than static frictional forces. Additionally, as more and more of the prosthesis is released from the surrounding sheath, the total normal force between the prosthesis and the sheath decreases.

This acts to further reduce the friction of deployment. The expanded portion of the prosthesis may even help pull the remaining compressed portion axially as the prosthesis expands within the surrounding runners. Finally, once an end of the prosthesis has firmly engaged the surrounding body lumen, the relationship between the prosthesis and the surrounding body lumen is largely set, so that deployment can proceed safely at a more rapid rate. As a result of all these interactions, it is generally desirable to decrease the mechanical advantage between handle 112 and sheath 32 as the sheath moves from a distal position 118 over the prosthesis to a proximal position 120, at which the prosthesis is fully deployed.

The use of variable threads 114 and the interaction between handle 112, slider 100, and the slotted tube 98 can be understand with reference to Figs. 12-17. Fig. 12 illustrates a mandril 122 over which handle 114 is molded to impose variable threads 114. The handle will often be molded in two halves over mandrel 122, with the two halves bonded axially. Mandrel 122 includes external threads 124 which vary in pitch along the axial length of the mandrel. Preferably, threads 124 comprise multi-lead threads having two or more helical thread elements. As a result, a distance 126 between adjacent thread elements is only one half of the pitch 128 at the distal end of mandrel 122. The use of multi-lead threads allows multiple elements to extend axially from the slider to engage the surrounding threads, and thereby enhances the stability of the slider.

As described above, distal pitch 128 is significantly less than a proximal pitch 130, so that rotation of the handle at a constant speed results in increased axial speed of the sheath relative to the prosthesis. Each rotation of handle 112 preferably moves sheath 32 an axial distance of about 0.25 inches when sheath 32 is adjacent covered position 118, while this same rotation of the handle preferably moves the sheath an axial distance of about 0.75 inches when the sheath is adjacent the deployed position 120. In other words, in the exemplary embodiment distal pitch 128 is about 0.25 inches, while proximal pitch 130 is about 0.75 inches. The

threads may vary linearly between the proximal and distal ends (as illustrated in Fig. 12), or may vary substantially step-wise as illustrated in Fig. 10. Still further alternatives are possible, such as a quadratic variation in pitch along the axial length of the threads.

As can be seen in Figs. 13 through 15, slider 100 may be formed by bonding a finned inner body 132 to an outer ring 134. Outer ring 134 includes opposed pins 136 which extend into the two helical elements of internal variable threads 114 in handle 112. The use of pins rather than external threads on outer ring 134 prevents binding between slider 100 and the handle when the pitch of the threads changes. Also illustrated in Fig. 13 is the interaction of slotted tube 98 and slider 100, whereby the slotted tube rotationally restrains the slider when handle 112 rotates. In some embodiments, slider 100 may include only an inner or outer body. For example, an inner body may have pins which extend through the slotted tube and into variable threads 114, or an outer body may have fins extending into the slotted tube. The use of inner and outer bodies may enhance the stability of the slider to prevent binding.

Generally, delivery system 30 (including housing 50 and actuation mechanism 90) will be formed from inexpensive polymeric materials, and will be undetachably secured together so that the delivery system is disposable after use. In the exemplary embodiment, core shaft 44 comprises a polyester ethylketone (PEEK), while shaft 34 may comprise a high-strength polymer such as PEBAX™. Slider 100 will typically be formed from molded polymers such as polycarbonate, while reinforcing tube 106 and slotted tube 98 may be formed from stainless steel or thermoplastic. Handle 112 and housing 50 will also typically comprise molded polymer structures.

Connector 56 (and the associated fitting at the proximal end of housing 50) is commercially available from Colder Products Company of St. Paul, Minnesota, under model number MPC 170-04T. Those skilled in the art should recognize that delivery system 30 will typically be substantially sealed to maintain hemostasis, typically using o-rings to seal

between reinforcing tube 106 and sheath 32, as well as between reinforcing rod 106 and shaft 34. The reinforcing rod will typically extend substantially through housing 50, but will not extend distally significantly beyond the housing to allow the delivery system to flex within the body lumen. As illustrated in Fig. 11, such flexibility may be enhanced by decreasing the diameter of sheath 32 proximally of the prosthesis.

While the exemplary embodiment of the present invention has been described in substantial detail by way of example and for clarity of understanding, a number of adaptations, modifications, and changes will be obvious to those skilled in the art. Hence, the scope of the present invention is limited solely by the appended claims.

WHAT IS CLAIMED IS:

1 1. A delivery system for use with a tubular
2 endoluminal prosthesis, the delivery system comprising:
3 a sheath having a proximal end, a distal end, and a
4 lumen capable of receiving the prosthesis near the distal end;
5 a member in the lumen of the sheath, the member
6 adapted for expelling the prosthesis from the lumen as the
7 sheath moves from a first position to a second position
8 relative to the member; and
9 an actuation mechanism attached to the member and
10 coupling a handle to the sheath with a mechanical advantage
11 which varies as the sheath moves between the first position
12 and the second position.

1 2. A delivery system as claimed in claim 1,
2 wherein a displacement of the handle relative to the member
3 effects a first displacement of the sheath relative to the
4 member when the sheath is adjacent the first position, and
5 wherein the handle displacement effects a second displacement
6 of the sheath which is different than the first sheath
7 displacement when the sheath is adjacent the second position.

1 3. A delivery system as claimed in claim 1,
2 wherein the first sheath displacement is smaller than the
3 second sheath displacement.

1 4. A delivery system as claimed in claim 1,
2 wherein the mechanical advantage when the sheath is adjacent
3 the first position is adapted to overcome static frictional
4 forces between the prosthesis and the sheath, and wherein the
5 mechanical advantage when the sheath is adjacent the second
6 position is adapted to overcome dynamic frictional forces
7 which are smaller than the static frictional forces, and to
8 enhance the speed of expelling the prosthesis from the sheath.

1 5. A delivery system as claimed in claim 1,
2 wherein the actuation mechanism comprises threads defining an

3 axis, and wherein a pitch of the threads varies along an axis
4 of the threads.

1 6. A delivery system as claimed in claim 5,
2 wherein the threads comprise multiple-lead threads, and
3 wherein the actuation mechanism further comprises a slider
4 having pins which engage the threads so rotation of one member
5 of the group consisting of the slider and the threads rotates
6 relative to the other.

1 7. A delivery system as claimed in claim 5,
2 wherein the handle comprises a tubular structure substantially
3 aligned with the sheath, the handle coupled to the threads so
4 that rotation of the handle about the axis of the sheath
5 effects movement of the member.

1 8. A delivery system as claimed in claim 1,
2 wherein the actuation mechanism, the sheath, and the member
3 comprise undetachably coupled disposable polymer structures.

1 9. A prosthetic delivery system for use with a
2 radially expandable tubular endoluminal prosthesis, the
3 delivery system comprising:

4 a sheath having a proximal end, a distal end, an
5 axis therebetween, and a lumen capable of receiving the
6 prosthesis near the distal end;

7 a member in the lumen for expelling the prosthesis
8 from the lumen as the sheath moves from a first position to a
9 second position relative to the member; and

10 an actuation mechanism attached to the member, the
11 actuation mechanism coupling the sheath to a handle, the
12 handle rotatable about an axis substantially parallel to the
13 axis of the sheath to effect movement of the sheath from the
14 first position to the second position.

1 10. A delivery system as claimed in claim 9,
2 wherein the actuation mechanism, the sheath, and the member
3 comprise undetachably coupled disposable polymer structures.

1 11. A delivery system as claimed in claim 9,
2 wherein the actuation mechanism further comprises a slider
3 and threads coupling the handle portion to the slider, the
4 slider being rotationally restrained relative to a housing so
5 that the slider moves axially when the handle rotates.

1 12. A delivery system as claimed in claim 11,
2 wherein the handle comprises a tubular structure disposed
3 substantially coaxially with the sheath.

1 13. A delivery system as claimed in claim 12,
2 wherein the rotatable handle portion has an inner surface
3 which defines the threads, the slider being coupled to the
4 member and engaging the threads to draw the member proximally
5 when the threads rotate.

1 14. A delivery system as claimed in claim 11,
2 wherein a pitch of the threads varies along an axial length of
3 the rotatable handle portion.

1 15. A delivery system as claimed in claim 9,
2 wherein the actuation mechanism can move the sheath axially a
3 distance of between about 7.0 inches and 10.0 inches relative
4 to the member.

1 16. A delivery system as claimed in claim 9,
2 further comprising an outer tube disposed over the sheath and
3 coupled to the housing so that the outer tube remains axially
4 aligned with the member when the sheath moves from the first
5 position to the second position.

1 17. A delivery system as claimed in claim 16,
2 further comprising an introducer valve capable of maintaining
3 hemostasis around the sheath and around the outer tube, and
4 sliding seals between the member and the sheath and between
5 the outer tube and the sheath.

1 18. A delivery system for inserting a tubular
2 endoluminal prosthesis into a patient body, the delivery
3 system comprising:

4 a sheath having a proximal end, a distal end, and a
5 lumen capable of receiving the prosthesis near the distal end;

6 a member disposed in the lumen and adapted for
7 expelling the prosthesis from the lumen as the sheath moves
8 from a first position to a second position relative to the
9 member;

10 an outer tube disposed over the sheath; and

11 a housing attached to the member near the proximal
12 end of the sheath, the housing coupled to the outer tube so
13 that the outer tube remains substantially axially aligned with
14 the member when the sheath moves from the first position to
15 the second position.

1 19. A method for deploying a radially expandable
2 tubular endoluminal prosthesis, the method comprising:

3 positioning the prosthesis at a target location in a
4 body lumen while the prosthesis is disposed within a lumen of
5 a sheath;

6 releasing the prosthesis from the sheath by
7 actuating a handle to withdraw the sheath proximally from a
8 first position to a second position, a displacement of the
9 handle effecting a first displacement of the sheath when the
10 sheath is adjacent the first position, the handle displacement
11 effecting a second displacement of the sheath which is
12 different than the first sheath displacement when the sheath
13 is adjacent the second position.

1 20. A method for deploying a radially expandable
2 tubular endoluminal prosthesis, the method comprising:

3 positioning the prosthesis at a target location in a
4 body lumen while the prosthesis is disposed within a lumen of
5 a sheath;

6 releasing the prosthesis from the sheath by rotating
7 a handle about an axis which is parallel to an axis of the
8 sheath to move the sheath axially from over the prosthesis.

1 21. A method for deploying a radially expandable
2 tubular endoluminal prosthesis, the method comprising:
3 inserting the prosthesis into the body lumen through
4 an introducer valve while the prosthesis is disposed within a
5 lumen of a sheath;
6 inserting an outer tube through the introducer
7 valve;
8 positioning the prosthesis at a target location in
9 the body lumen;
10 releasing the prosthesis from the sheath by
11 withdrawing the sheath and restraining the prosthesis with a
12 member disposed within the sheath; and
13 restraining the member axially relative to the outer
14 tube while releasing the prosthesis so that friction between
15 the introducer valve and the outer tube helps prevent movement
16 of the prosthesis from the target location.

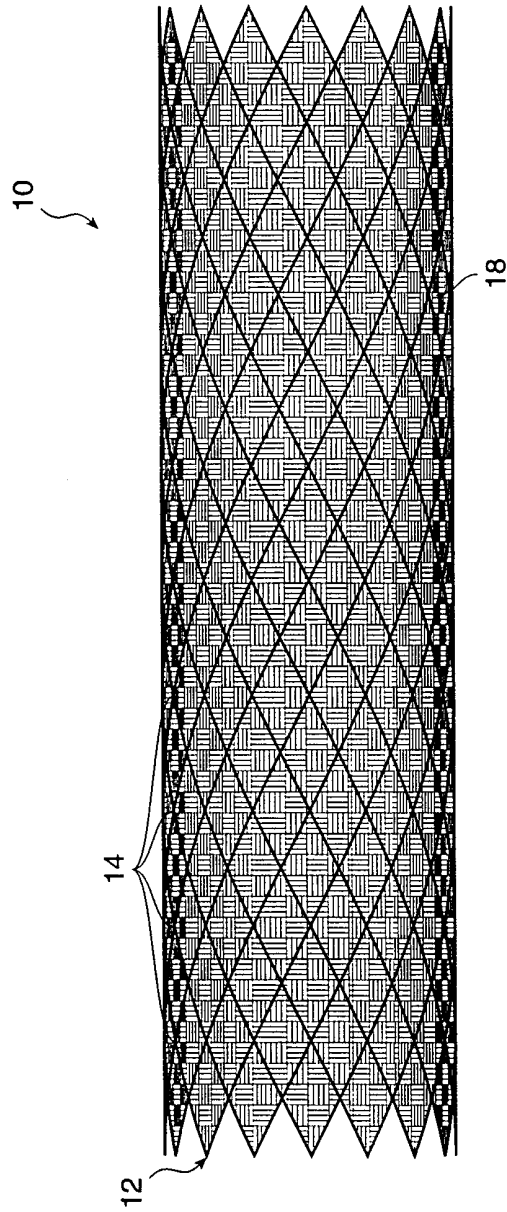

FIG. 1

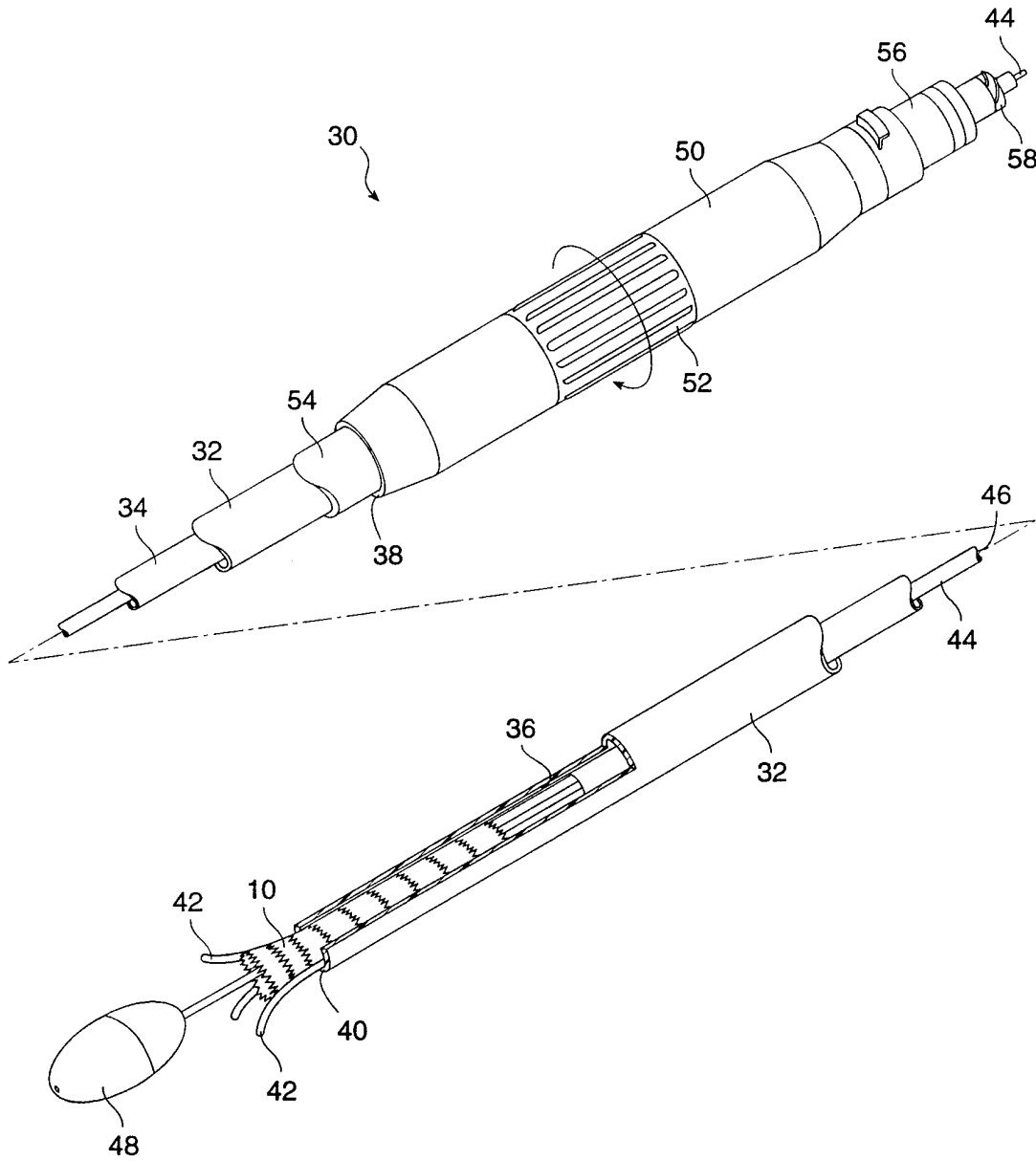

FIG. 2

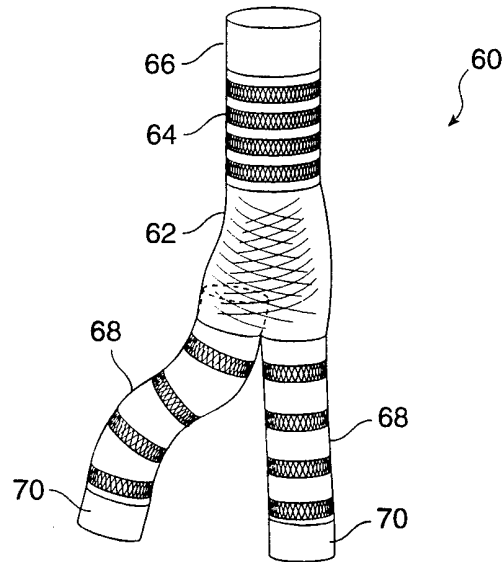

FIG. 3

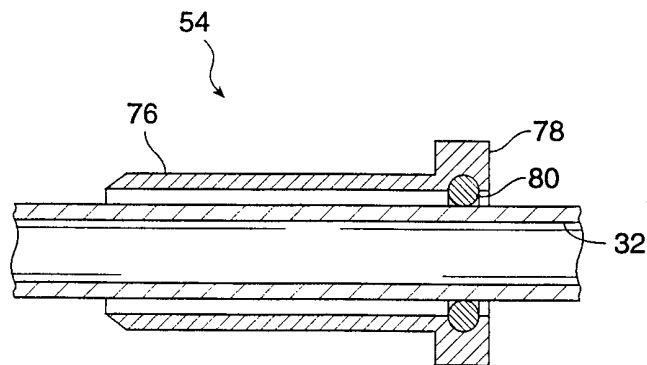

FIG. 5

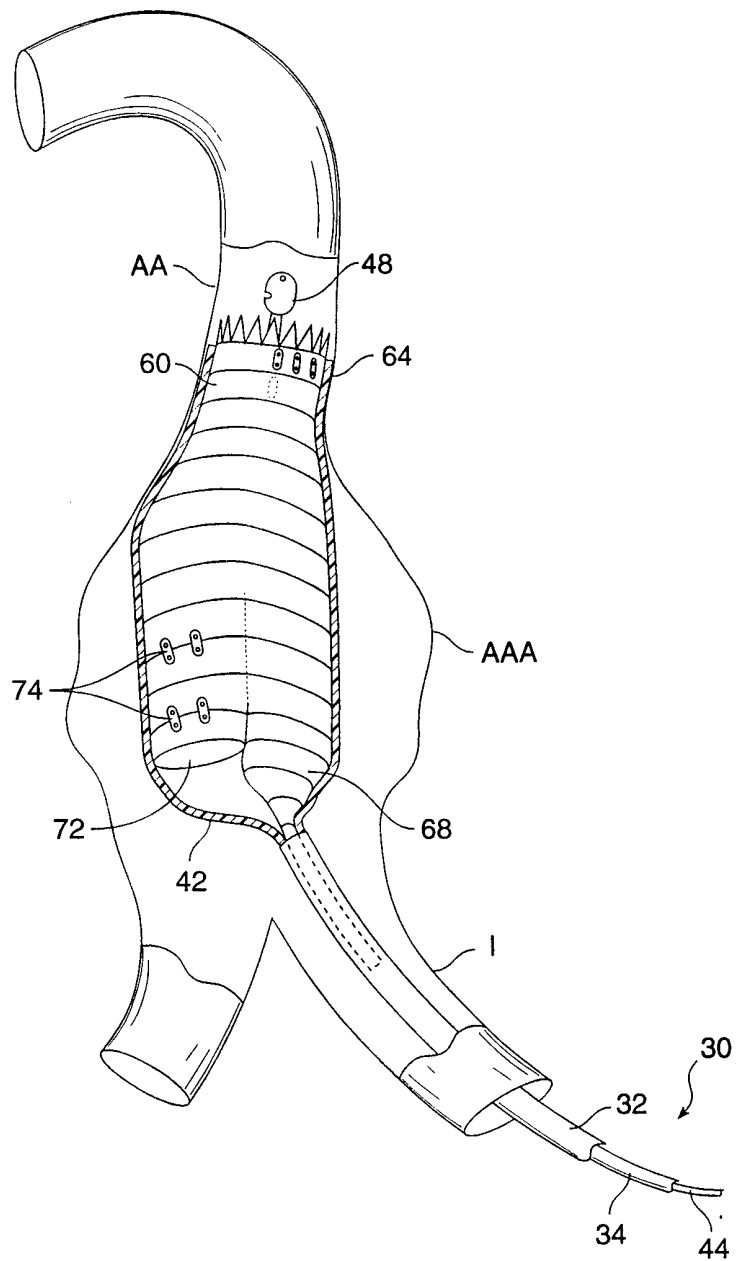

FIG. 4

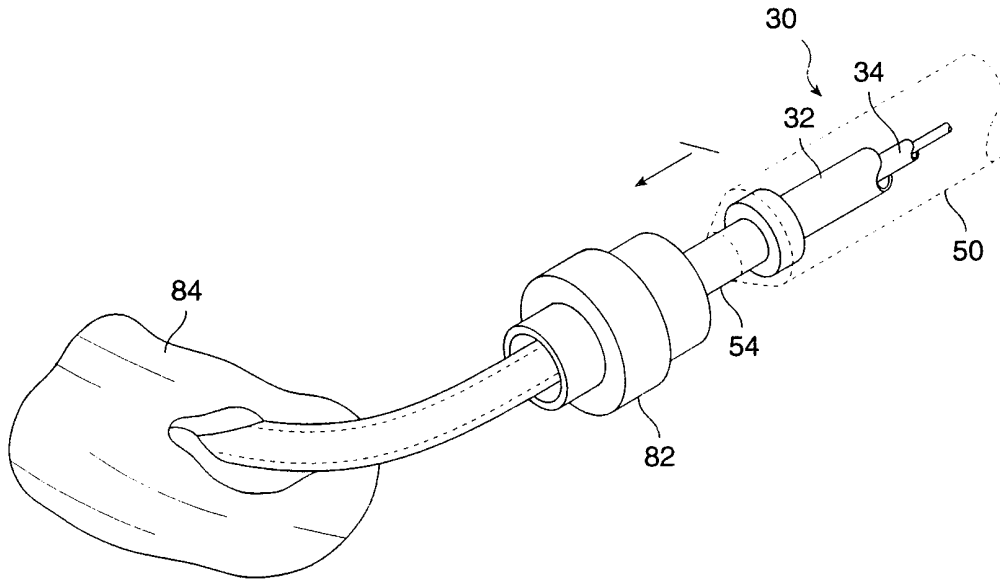

FIG. 6

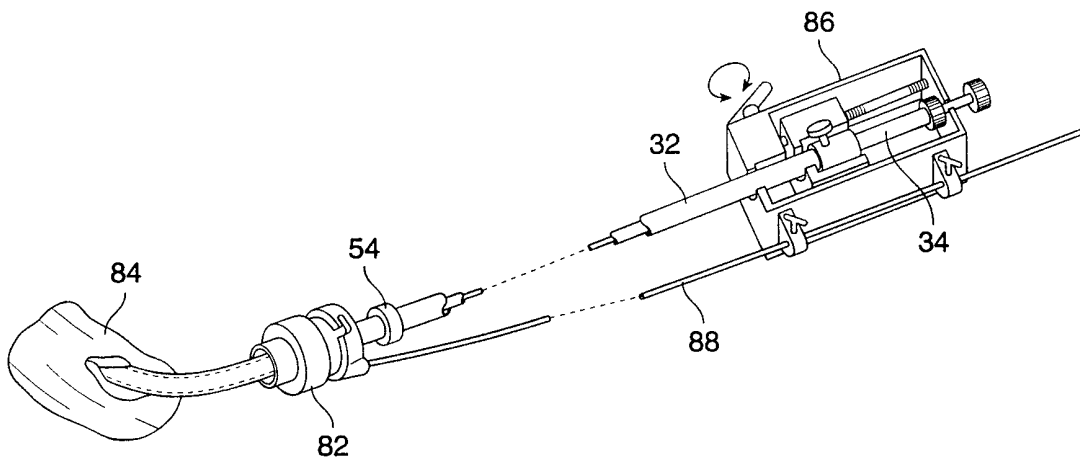

FIG. 7

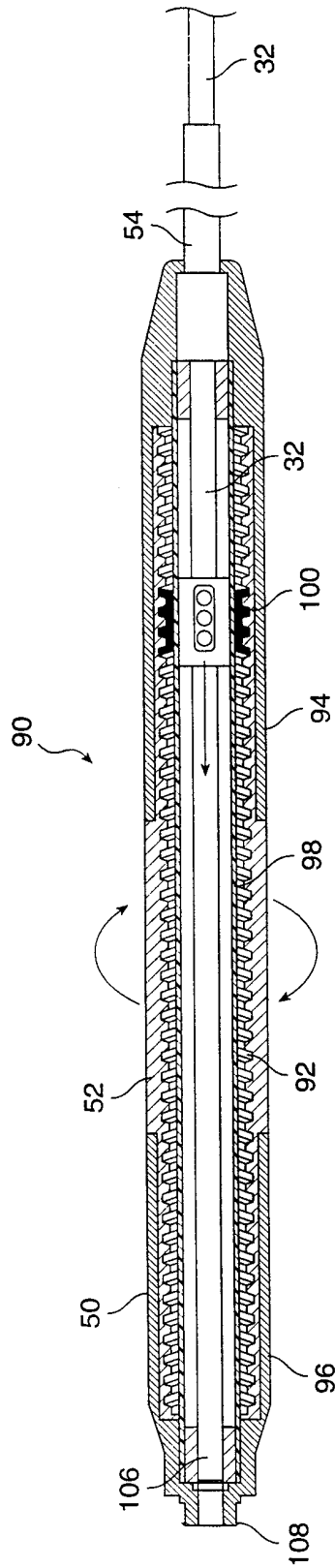

FIG. 8

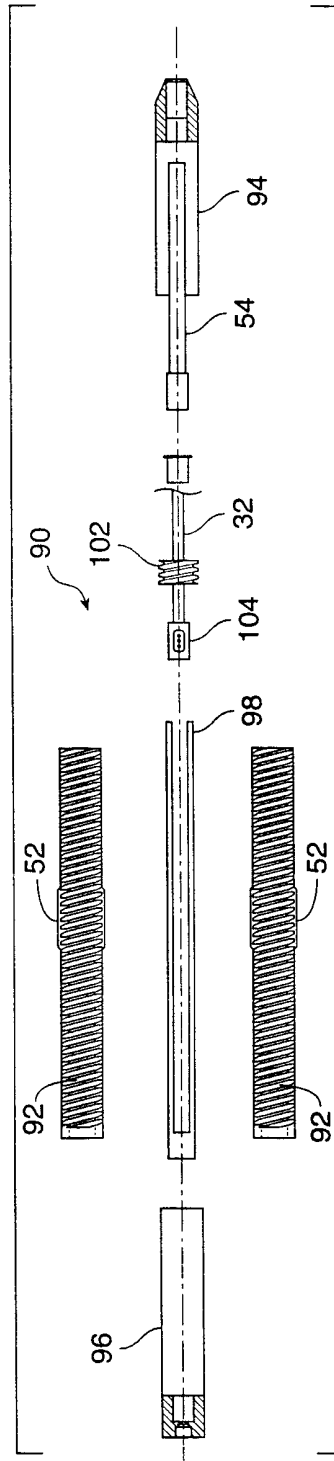

FIG. 9

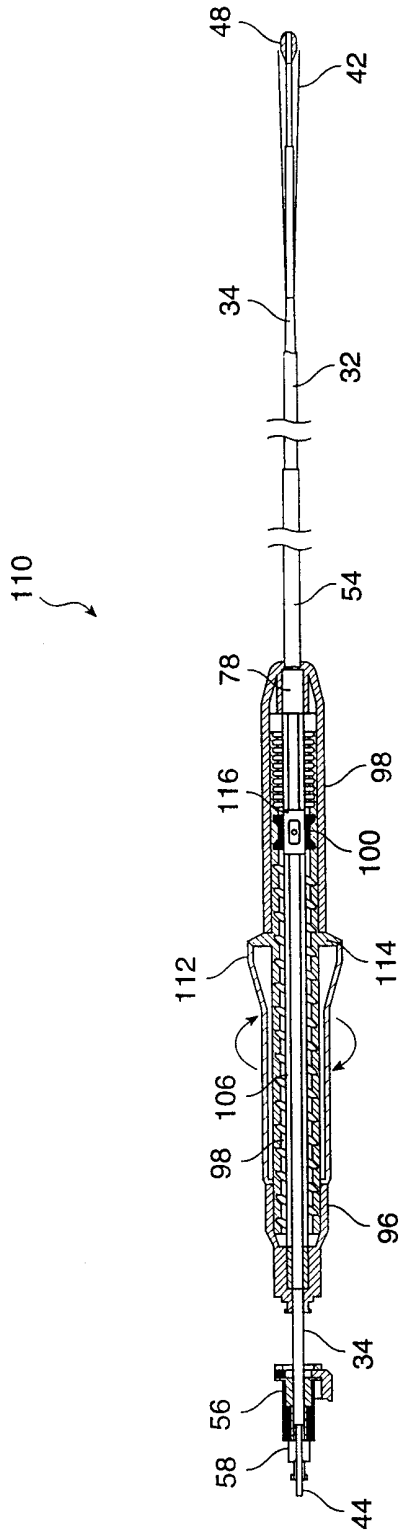

FIG. 10

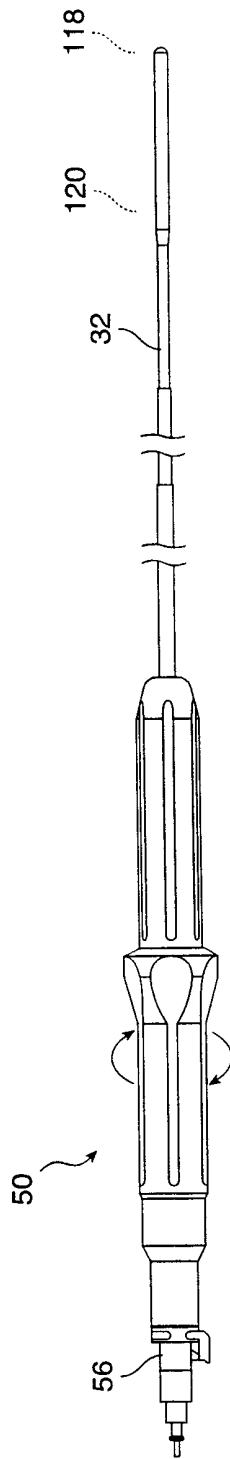

FIG. 11

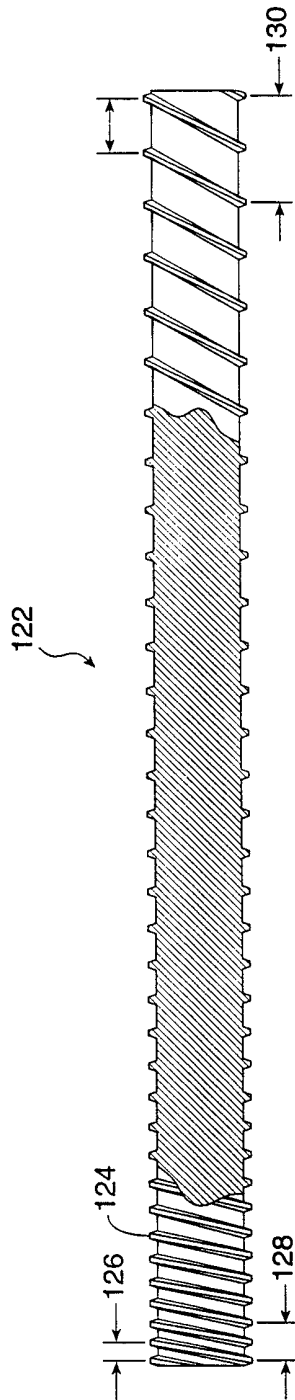

FIG. 12

11/12

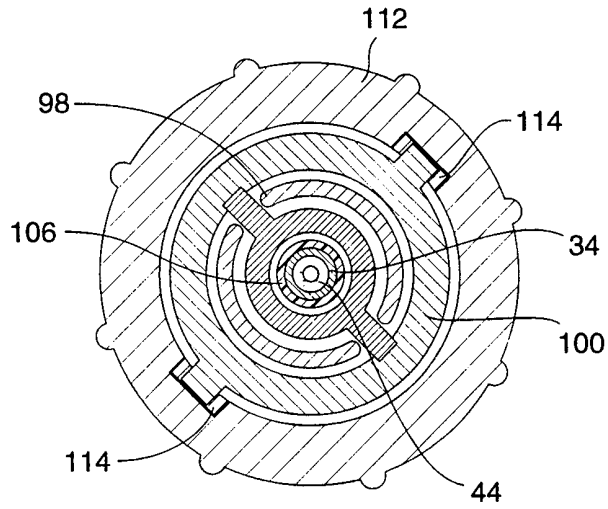

FIG. 13

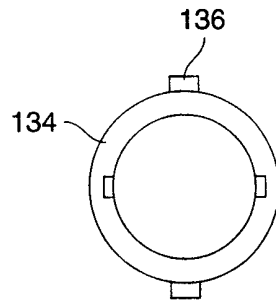

FIG. 14

12/12

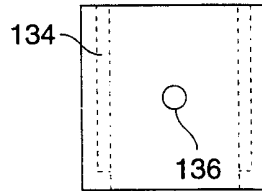

FIG. 15

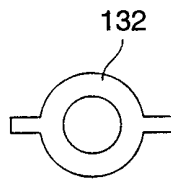

FIG. 16

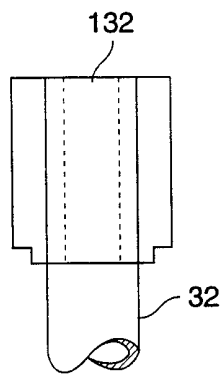

FIG. 17

INTERNATIONAL SEARCH REPORT

International Application No
PCT/US 98/09800

A. CLASSIFICATION OF SUBJECT MATTER IPC 6 A61F2/06		
According to International Patent Classification (IPC) or to both national classification and IPC		
B. FIELDS SEARCHED		
Minimum documentation searched (classification system followed by classification symbols) IPC 6 A61F A61M		
Documentation searched other than minimum documentation to the extent that such documents are included in the fields searched		
Electronic data base consulted during the international search (name of data base and, where practical, search terms used)		
C. DOCUMENTS CONSIDERED TO BE RELEVANT		
Category	Citation of document, with indication, where appropriate, of the relevant passages	Relevant to claim No.
A	EP 0 274 846 A (ADVANCED SURGICAL INTERVENTION) 20 July 1988 see abstract; figures 1-5,9-14 ---	1-18
A	EP 0 361 314 A (ADVANCED CARDIOVASCULAR SYSTEMS, INC.) 4 April 1990 see abstract; figures 1-5 ---	1-18
A	WO 93 15790 A (AVITALL BOAZ) 19 August 1993 see abstract; figures 1-4 ---	1-18
A	EP 0 732 087 A (ADVANCED CARDIOVASCULAR SYSTEMS, INC.) 18 September 1996 ---	
A	US 5 484 418 A (WILLIAMS ET AL.) 16 January 1996 cited in the application -----	
<input type="checkbox"/> Further documents are listed in the continuation of box C. <input checked="" type="checkbox"/> Patent family members are listed in annex.		
* Special categories of cited documents :		
"A" document defining the general state of the art which is not considered to be of particular relevance "E" earlier document but published on or after the international filing date "L" document which may throw doubts on priority claim(s) or which is cited to establish the publication date of another citation or other special reason (as specified) "O" document referring to an oral disclosure, use, exhibition or other means "P" document published prior to the international filing date but later than the priority date claimed	"T" later document published after the international filing date or priority date and not in conflict with the application but cited to understand the principle or theory underlying the invention "X" document of particular relevance; the claimed invention cannot be considered novel or cannot be considered to involve an inventive step when the document is taken alone "Y" document of particular relevance; the claimed invention cannot be considered to involve an inventive step when the document is combined with one or more other such documents, such combination being obvious to a person skilled in the art. "&" document member of the same patent family	
Date of the actual completion of the international search <div style="text-align: center; font-weight: bold;">9 November 1998</div>	Date of mailing of the international search report <div style="text-align: center; font-weight: bold;">17/11/1998</div>	
Name and mailing address of the ISA European Patent Office, P.B. 5818 Patentlaan 2 NL - 2280 HV Rijswijk Tel. (+31-70) 340-2040, Tx. 31 651 epo nl, Fax: (+31-70) 340-3016	Authorized officer <div style="text-align: center; font-weight: bold;">Michels, N</div>	

INTERNATIONAL SEARCH REPORT

International application No.

PCT/US 98/09800

Box I Observations where certain claims were found unsearchable (Continuation of item 1 of first sheet)

This International Search Report has not been established in respect of certain claims under Article 17(2)(a) for the following reasons:

1. Claims Nos.: 19-21
because they relate to subject matter not required to be searched by this Authority, namely:
Rule 39.1(iv) PCT - Method for treatment of the human or animal body by surgery.
2. Claims Nos.:
because they relate to parts of the International Application that do not comply with the prescribed requirements to such an extent that no meaningful International Search can be carried out, specifically:
3. Claims Nos.:
because they are dependent claims and are not drafted in accordance with the second and third sentences of Rule 6.4(a).

Box II Observations where unity of invention is lacking (Continuation of item 2 of first sheet)

This International Searching Authority found multiple inventions in this international application, as follows:

1. As all required additional search fees were timely paid by the applicant, this International Search Report covers all searchable claims.
2. As all searchable claims could be searched without effort justifying an additional fee, this Authority did not invite payment of any additional fee.
3. As only some of the required additional search fees were timely paid by the applicant, this International Search Report covers only those claims for which fees were paid, specifically claims Nos.:
4. No required additional search fees were timely paid by the applicant. Consequently, this International Search Report is restricted to the invention first mentioned in the claims: it is covered by claims Nos.:

Remark on Protest

- The additional search fees were accompanied by the applicant's protest.
- No protest accompanied the payment of additional search fees.

INTERNATIONAL SEARCH REPORT

Information on patent family members

International Application No

PCT/US 98/09800

Patent document cited in search report	A	Publication date	Patent family member(s)	Publication date
EP 0274846	A	20-07-1988	US 4893623	16-01-1990
			US 4762128	09-08-1988
			AU 649650	02-06-1994
			AU 7120091	02-05-1991
			AU 7120191	02-05-1991
			AU 609431	02-05-1991
			AU 8210087	09-06-1988
			DE 3789053	24-03-1994
			DE 3789053	11-08-1994
			ES 2049219	16-04-1994
			JP 2558482	27-11-1996
			JP 63214264	06-09-1988
			US 5527336	18-06-1996
			US 5752971	19-05-1998
US 5312430	17-05-1994			
ZA 8709207	06-06-1988			
EP 0361314	A	04-04-1990	US 4898577	06-02-1990
			CA 1309633	03-11-1992
			DE 68926599	11-07-1996
			DE 68926599	02-01-1997
			JP 2193681	31-07-1990
			US 5030204	09-07-1991
WO 9315790	A	19-08-1993	US 5354297	11-10-1994
			US 5327905	12-07-1994
			CA 2117487	19-08-1993
			EP 0625919	30-11-1994
			JP 7504834	01-06-1995
			US 5642736	01-07-1997
			CN 1082382	23-02-1994
EP 0732087	A	18-09-1996	US 5647857	15-07-1997
			CA 2171787	17-09-1996
			JP 8322943	10-12-1996
US 5484418	A	16-01-1996	US 5395349	07-03-1995
			US 5256150	26-10-1993
			US 5653697	05-08-1997
			AU 693472	02-07-1998

INTERNATIONAL SEARCH REPORT

information on patent family members

International Application No

PCT/US 98/09800

Patent document cited in search report	Publication date	Patent family member(s)	Publication date
US 5484418 A		AU 7634594 A	14-03-1995
		CA 2168369 A	23-02-1995
		EP 0746352 A	11-12-1996
		JP 9501594 T	18-02-1997
		WO 9505207 A	23-02-1995
		AU 661064 B	13-07-1995
		AU 2830992 A	17-06-1993
		CA 2083000 A,C	14-06-1993
		EP 0546712 A	16-06-1993
		JP 6197981 A	19-07-1994