



US010545861B2

(12) **United States Patent**
Dreier et al.

(10) **Patent No.:** **US 10,545,861 B2**

(45) **Date of Patent:** **Jan. 28, 2020**

(54) **DISTRIBUTED INTEGRATED HIGH-SPEED
SOLID-STATE NON-VOLATILE
RANDOM-ACCESS MEMORY**

(56) **References Cited**

U.S. PATENT DOCUMENTS

(71) Applicant: **PURE STORAGE, INC.**, Mountain View, CA (US)

5,208,813 A 5/1993 Stailmo
5,403,639 A 4/1995 Belsan
(Continued)

(72) Inventors: **Roland Dreier**, Mountain View, CA (US); **Ronald Karr**, Palo Alto, CA (US); **Peter E. Kirkpatrick**, Mountain View, CA (US)

FOREIGN PATENT DOCUMENTS

CN 103370685 A 10/2013
CN 103370686 A 10/2013
(Continued)

(73) Assignee: **PURE STORAGE, INC.**, Mountain View, CA (US)

OTHER PUBLICATIONS

(*) Notice: Subject to any disclaimer, the term of this patent is extended or adjusted under 35 U.S.C. 154(b) by 61 days.

Microsoft Corporation, "GCSeitings.IsServerGC Property", Retrieved Oct. 27, 2013 via the WayBack Machine, 3 pages.

(Continued)

(21) Appl. No.: **15/582,395**

Primary Examiner — Yong J Choe

(22) Filed: **Apr. 28, 2017**

(74) *Attorney, Agent, or Firm* — Womble Bond Dickinson (US) LLP; Daniel E. Ovanezian

(65) **Prior Publication Data**

US 2018/0095872 A1 Apr. 5, 2018

Related U.S. Application Data

(60) Provisional application No. 62/403,899, filed on Oct. 4, 2016.

(51) **Int. Cl.**
G06F 12/02 (2006.01)
G06F 3/06 (2006.01)
(Continued)

(57) **ABSTRACT**

A system may include embedded storage devices, each including: a first solid state drive (SSD) storage portion and a second non-volatile random-access memory (NVRAM) portion. The NVRAM portion includes a random access memory (RAM) device, a processing device, and an energy source, where the first SSD portion and the second NVRAM portion are separately addressable. The system further includes a storage system controller, operatively coupled to the embedded storage devices via a network. The storage system controller may be to: determine that data is to be stored in the first SSD storage portion of a first embedded storage device of the plurality of embedded storage devices; and buffer the data in the second NVRAM portion of a second embedded storage device of the plurality of embedded storage devices.

(52) **U.S. Cl.**
CPC **G06F 12/0246** (2013.01); **G06F 3/067** (2013.01); **G06F 3/0689** (2013.01);
(Continued)

(58) **Field of Classification Search**
CPC combination set(s) only.
See application file for complete search history.

22 Claims, 15 Drawing Sheets

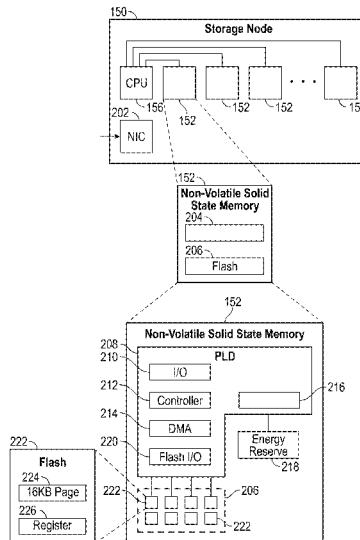

- (51) **Int. Cl.**
H04L 29/08 (2006.01)
G06F 1/30 (2006.01)
- (52) **U.S. Cl.**
 CPC **H04L 67/104** (2013.01); **H04L 67/1095**
 (2013.01); **H04L 67/1097** (2013.01); **G06F**
1/30 (2013.01); **G06F 3/0659** (2013.01)

(56) **References Cited**

U.S. PATENT DOCUMENTS

5,535,312 A * 7/1996 Hammer G06K 15/00
 358/1.16

5,940,838 A 8/1999 Schmuck et al.
 6,263,350 B1 7/2001 Wollrath et al.
 6,412,045 B1 6/2002 DeKoning et al.
 6,718,448 B1 4/2004 Ofer
 6,757,769 B1 6/2004 Ofer
 6,799,283 B1 9/2004 Tamai et al.
 6,834,298 B1 12/2004 Singer et al.
 6,850,938 B1 2/2005 Sadjadi
 6,915,434 B1 7/2005 Kuroda
 6,973,549 B1 12/2005 Testardi
 7,028,216 B2 4/2006 Aizawa et al.
 7,028,218 B2 4/2006 Schwarm et al.
 7,039,827 B2 5/2006 Meyer et al.
 7,216,164 B1 5/2007 Whitmore et al.
 7,783,682 B1 8/2010 Patterson
 7,873,619 B1 1/2011 Faibish et al.
 7,913,300 B1 3/2011 Flank et al.
 7,933,936 B2 4/2011 Aggarwal et al.
 7,979,613 B2 7/2011 Zohar et al.
 8,086,652 B1 12/2011 Bisson et al.
 8,117,464 B1 2/2012 Kogelnik
 8,200,887 B2 6/2012 Bennett
 8,205,065 B2 6/2012 Matze
 8,352,540 B2 1/2013 Anglin et al.
 8,527,544 B1 9/2013 Colgrove et al.
 8,560,747 B1 10/2013 Tan et al.
 8,621,241 B1 12/2013 Stephenson
 8,700,875 B1 4/2014 Barron et al.
 8,751,463 B1 6/2014 Chamness
 8,806,160 B2 8/2014 Colgrove et al.
 8,874,850 B1 10/2014 Goodson et al.
 8,959,305 B1 2/2015 Lecrone et al.
 9,081,713 B1 7/2015 Bennett
 9,189,334 B2 11/2015 Bennett
 9,311,182 B2 4/2016 Bennett
 9,423,967 B2 8/2016 Colgrove et al.
 9,436,396 B2 9/2016 Colgrove et al.
 9,436,720 B2 9/2016 Colgrove et al.
 9,454,476 B2 9/2016 Colgrove et al.
 9,454,477 B2 9/2016 Colgrove et al.
 9,513,820 B1 12/2016 Shalev
 9,516,016 B2 12/2016 Colgrove et al.
 9,552,248 B2 1/2017 Miller et al.
 9,632,870 B2 4/2017 Bennett

2002/0038436 A1 3/2002 Suzuki
 2002/0087544 A1 7/2002 Selkirk et al.
 2002/0178335 A1 11/2002 Selkirk et al.
 2003/0140209 A1 7/2003 Testardi
 2004/0049572 A1 3/2004 Yamamoto et al.
 2005/0066095 A1 3/2005 Mullick et al.
 2005/0216535 A1 9/2005 Saika et al.
 2005/0223154 A1 10/2005 Uemura
 2006/0074940 A1 4/2006 Craft et al.
 2006/0136365 A1 6/2006 Kedem et al.
 2006/0155946 A1 7/2006 Ji
 2007/0067585 A1 3/2007 Ueda et al.
 2007/0109856 A1 5/2007 Pellicone et al.
 2007/0162954 A1 7/2007 Pela
 2007/0171562 A1 7/2007 Maejima et al.
 2007/0174673 A1 7/2007 Kawaguchi et al.
 2007/0220313 A1 9/2007 Katsuragi et al.
 2007/0245090 A1 10/2007 King et al.
 2007/0266179 A1 11/2007 Chavan et al.
 2008/0059699 A1 3/2008 Kubo et al.

2008/0065852 A1 3/2008 Moore et al.
 2008/0134174 A1 6/2008 Sheu et al.
 2008/0155191 A1 6/2008 Anderson et al.
 2008/0178040 A1 7/2008 Kobayashi
 2008/0209096 A1 8/2008 Lin et al.
 2008/0244205 A1 10/2008 Amano et al.
 2008/0275928 A1 11/2008 Shuster
 2008/0282045 A1 11/2008 Biswas et al.
 2008/0285083 A1 11/2008 Aonuma
 2008/0307270 A1 12/2008 Li
 2009/0006587 A1 1/2009 Richter
 2009/0037662 A1 2/2009 La Frese et al.
 2009/0204858 A1 8/2009 Kawaba
 2009/0228648 A1 9/2009 Wack
 2009/0300084 A1 12/2009 Whitehouse
 2010/0057673 A1 3/2010 Savov
 2010/0058026 A1 3/2010 Heil et al.
 2010/0067706 A1 3/2010 Anan et al.
 2010/0077205 A1 3/2010 Ekstrom et al.
 2010/0082879 A1 4/2010 McKean et al.
 2010/0106905 A1 4/2010 Kurashige et al.
 2010/0153620 A1 6/2010 McKean et al.
 2010/0153641 A1 6/2010 Jagadish et al.
 2010/0191897 A1 7/2010 Zhang et al.
 2010/0250802 A1 9/2010 Waugh et al.
 2010/0250882 A1 9/2010 Hutchison et al.
 2010/0281225 A1 11/2010 Chen et al.
 2010/0287327 A1 11/2010 Li et al.
 2011/0072300 A1 3/2011 Rousseau
 2011/0121231 A1 6/2011 Haas et al.
 2011/0145598 A1 6/2011 Smith et al.
 2011/0161559 A1 6/2011 Yurzola et al.
 2011/0167221 A1 7/2011 Pangal et al.
 2011/0238634 A1 9/2011 Kobara
 2012/0023375 A1 1/2012 Dutta et al.
 2012/0036309 A1 2/2012 Dillow et al.
 2012/0117029 A1 5/2012 Gold
 2012/0198175 A1 8/2012 Atkisson
 2012/0330954 A1 12/2012 Sivasubramanian et al.
 2013/0042052 A1 2/2013 Colgrove et al.
 2013/0046995 A1 2/2013 Movshovitz
 2013/0047029 A1 2/2013 Ikeuchi et al.
 2013/0091102 A1 4/2013 Nayak
 2013/0205110 A1 8/2013 Kettner
 2013/0227236 A1 8/2013 Flynn et al.
 2013/0275391 A1 10/2013 Batwara et al.
 2013/0275656 A1 10/2013 Talagala et al.
 2013/0283058 A1 10/2013 Fiske et al.
 2013/0290648 A1 10/2013 Shao et al.
 2013/0318314 A1 11/2013 Markus et al.
 2013/0339303 A1 12/2013 Potter et al.
 2014/0052946 A1 2/2014 Kimmel
 2014/0068791 A1 3/2014 Resch
 2014/0089730 A1 3/2014 Watanabe et al.
 2014/0101361 A1 4/2014 Gschwind
 2014/0143517 A1 5/2014 Jin et al.
 2014/0172929 A1 6/2014 Sedayao et al.
 2014/0189203 A1* 7/2014 Suzuki G06F 12/0246
 711/103

2014/0201150 A1 7/2014 Kumarasamy et al.
 2014/0215129 A1 7/2014 Kuzmin et al.
 2014/0229131 A1 8/2014 Cohen et al.
 2014/0229452 A1 8/2014 Serita et al.
 2014/0281308 A1 9/2014 Lango et al.
 2014/0325115 A1 10/2014 Ramsundar et al.
 2015/0019797 A1* 1/2015 Huang G06F 12/0246
 711/103

2015/0234709 A1 8/2015 Koarashi
 2015/0244775 A1 8/2015 Vibhor et al.
 2015/0278534 A1 10/2015 Thiyagarajan et al.
 2016/0019114 A1 1/2016 Han et al.
 2016/0098191 A1 4/2016 Golden et al.
 2016/0098199 A1 4/2016 Golden et al.
 2018/0089044 A1* 3/2018 Guim Bernat G06F 11/2069

FOREIGN PATENT DOCUMENTS

CN 104025010 B 11/2016
 EP 3066610 A1 9/2016

(56)

References Cited

FOREIGN PATENT DOCUMENTS

EP	3082047	A1	10/2016
EP	3120235	A	1/2017
JP	2007-087036	A	4/2007
JP	2007-094472	A	4/2007
JP	2008-250667	A	10/2008
JP	2010-211681	A	9/2010
WO	WO-1995/002349	A1	1/1995
WO	WO-1999/013403	A1	3/1999
WO	WO-2008/102347	A1	8/2008
WO	WO-2010/071655	A1	6/2010

OTHER PUBLICATIONS

Microsoft Corporation, "Fundamentals of Garbage Collection",
Retrieved Aug. 30, 2013 via the WayBack Machine, 11 pages.

* cited by examiner

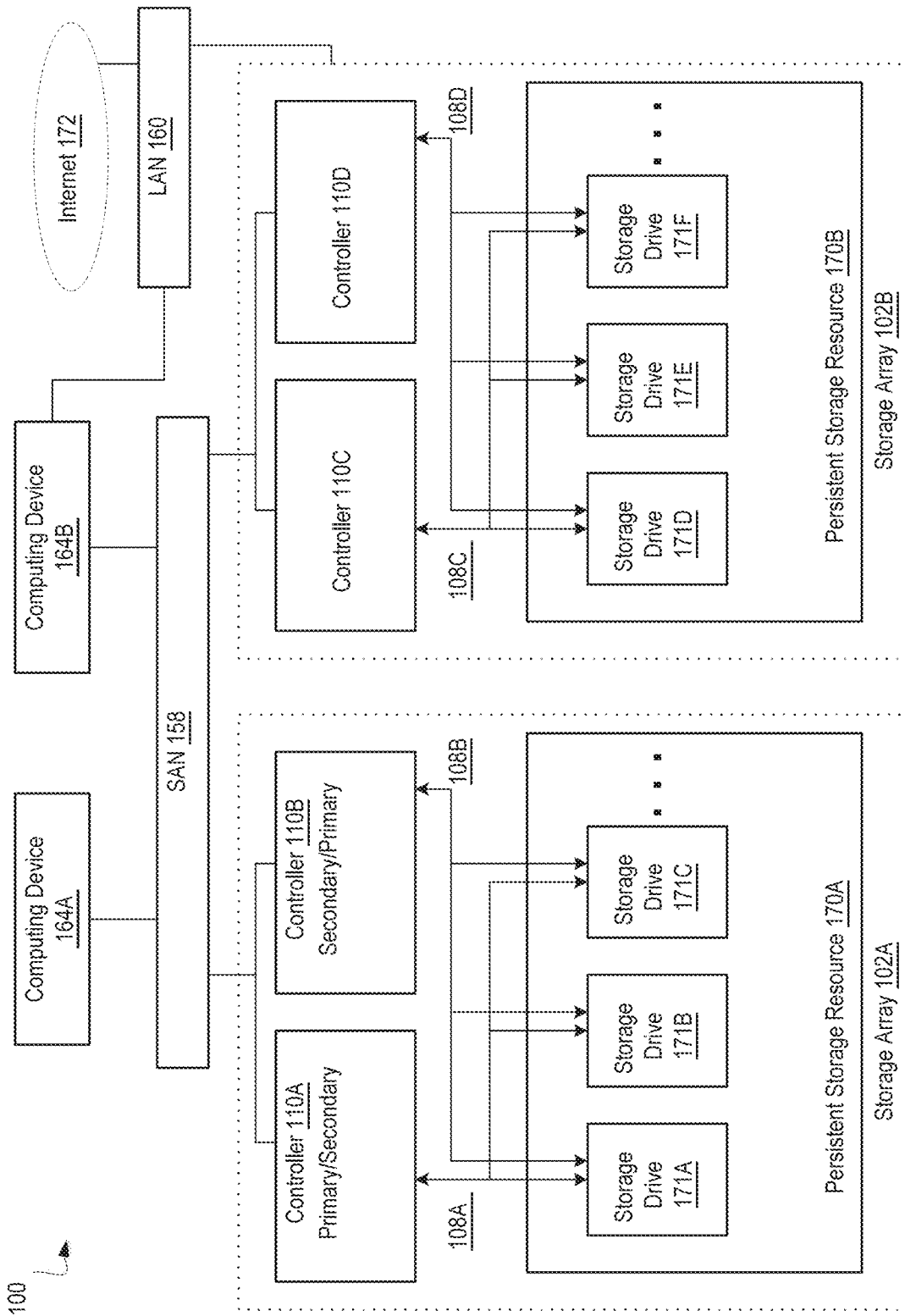

FIG. 1A

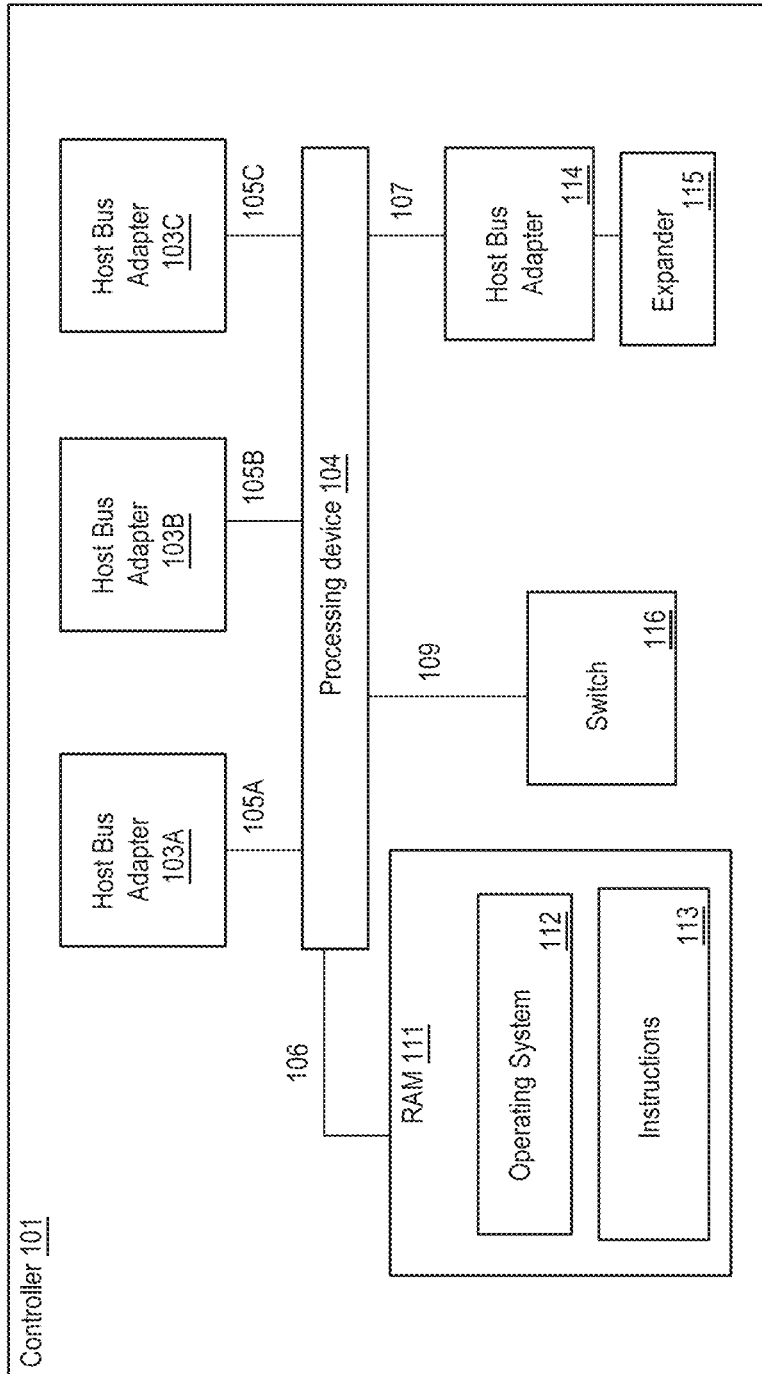

FIG. 1B

117

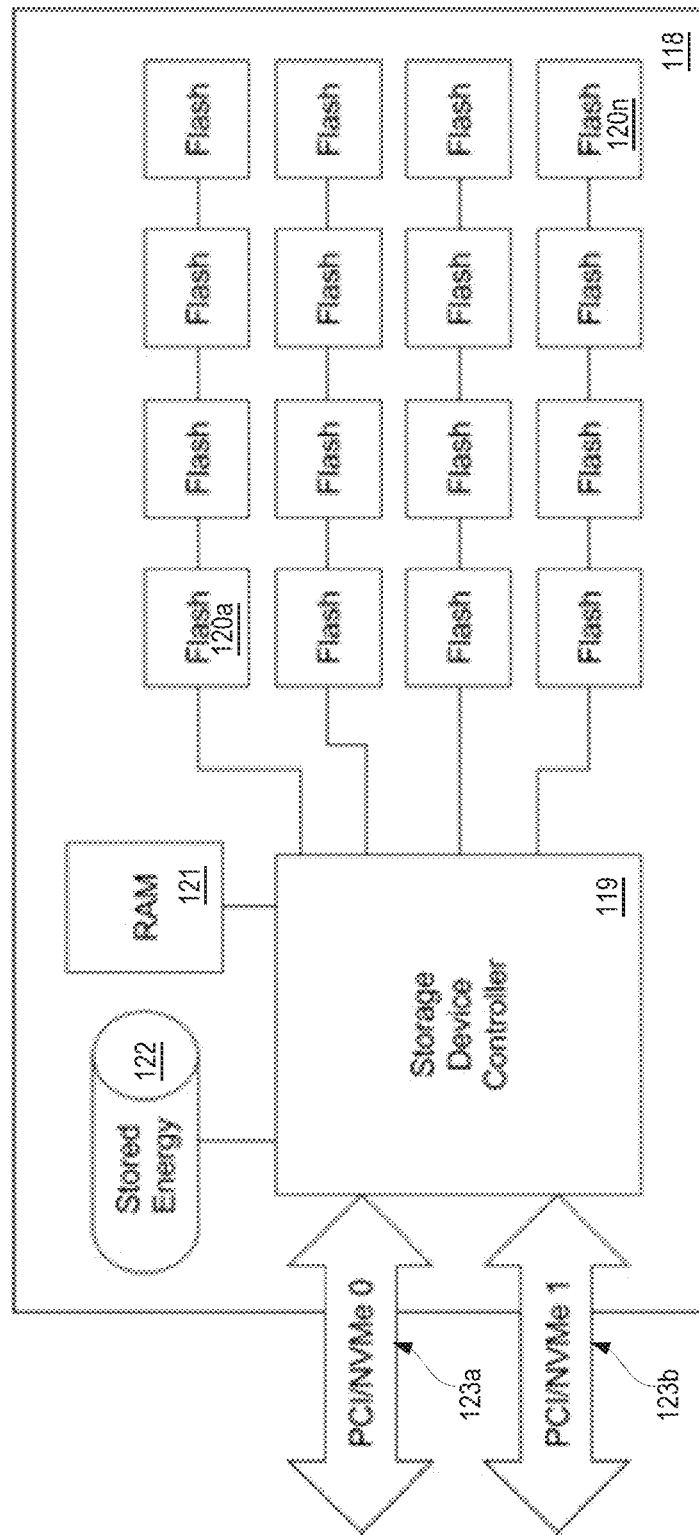

FIG. 1C

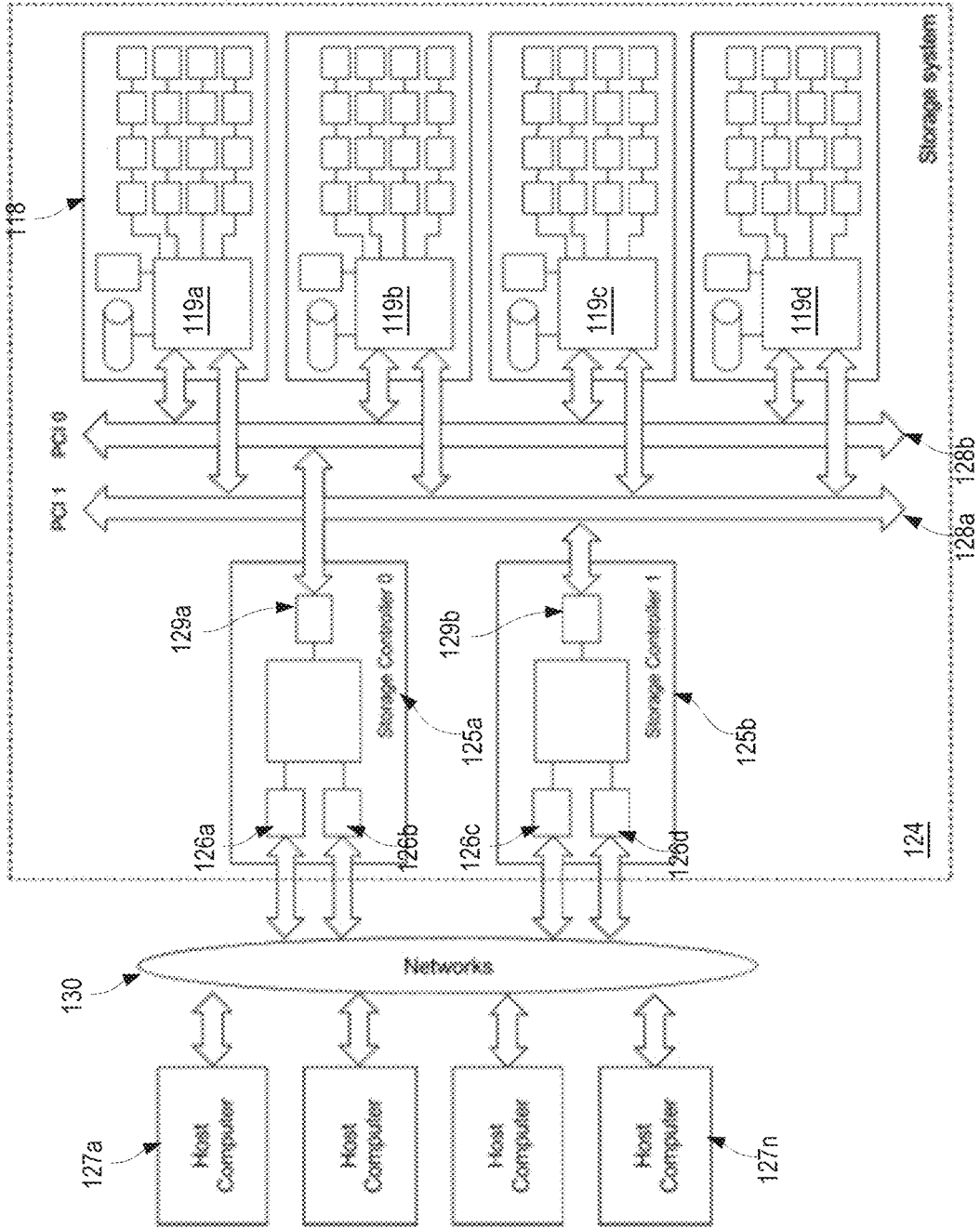

FIG. 1D

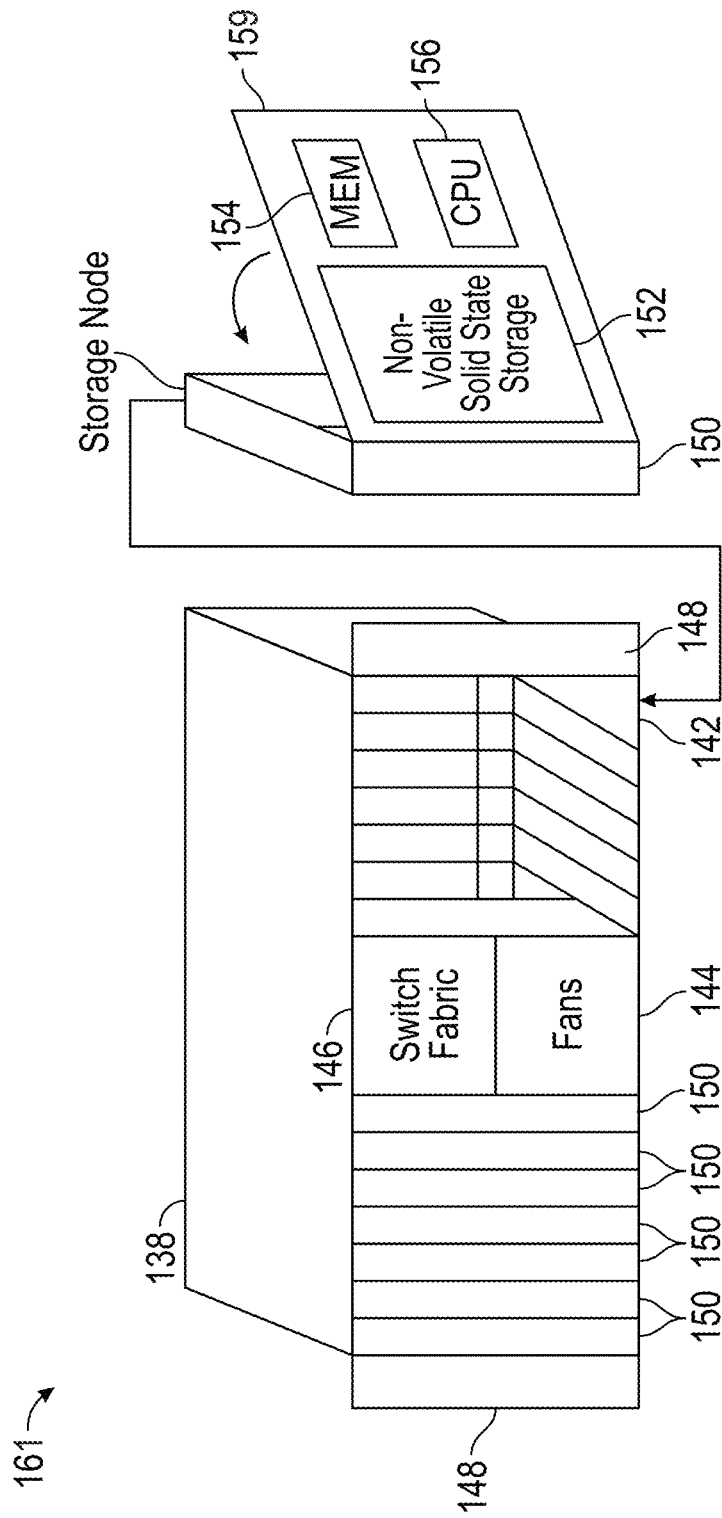

FIG. 2A

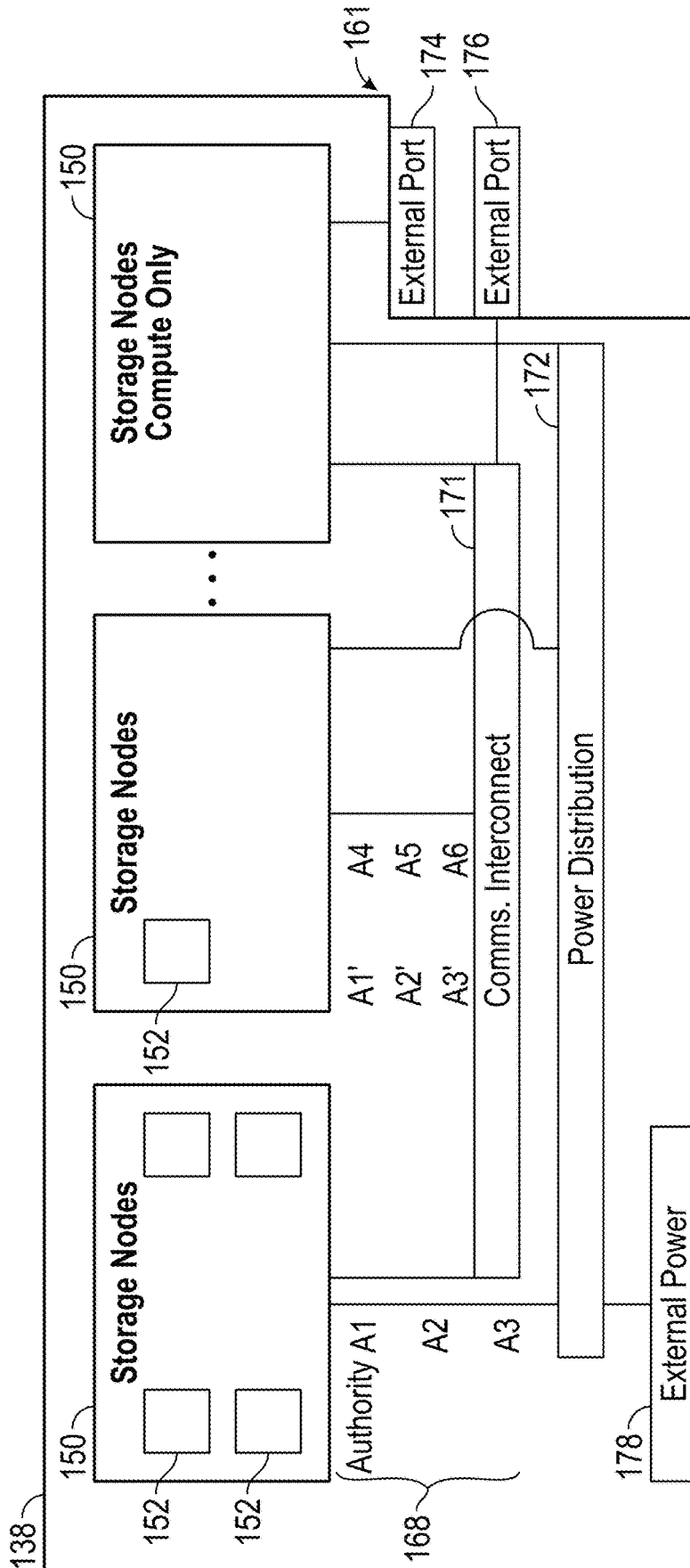

FIG. 2B

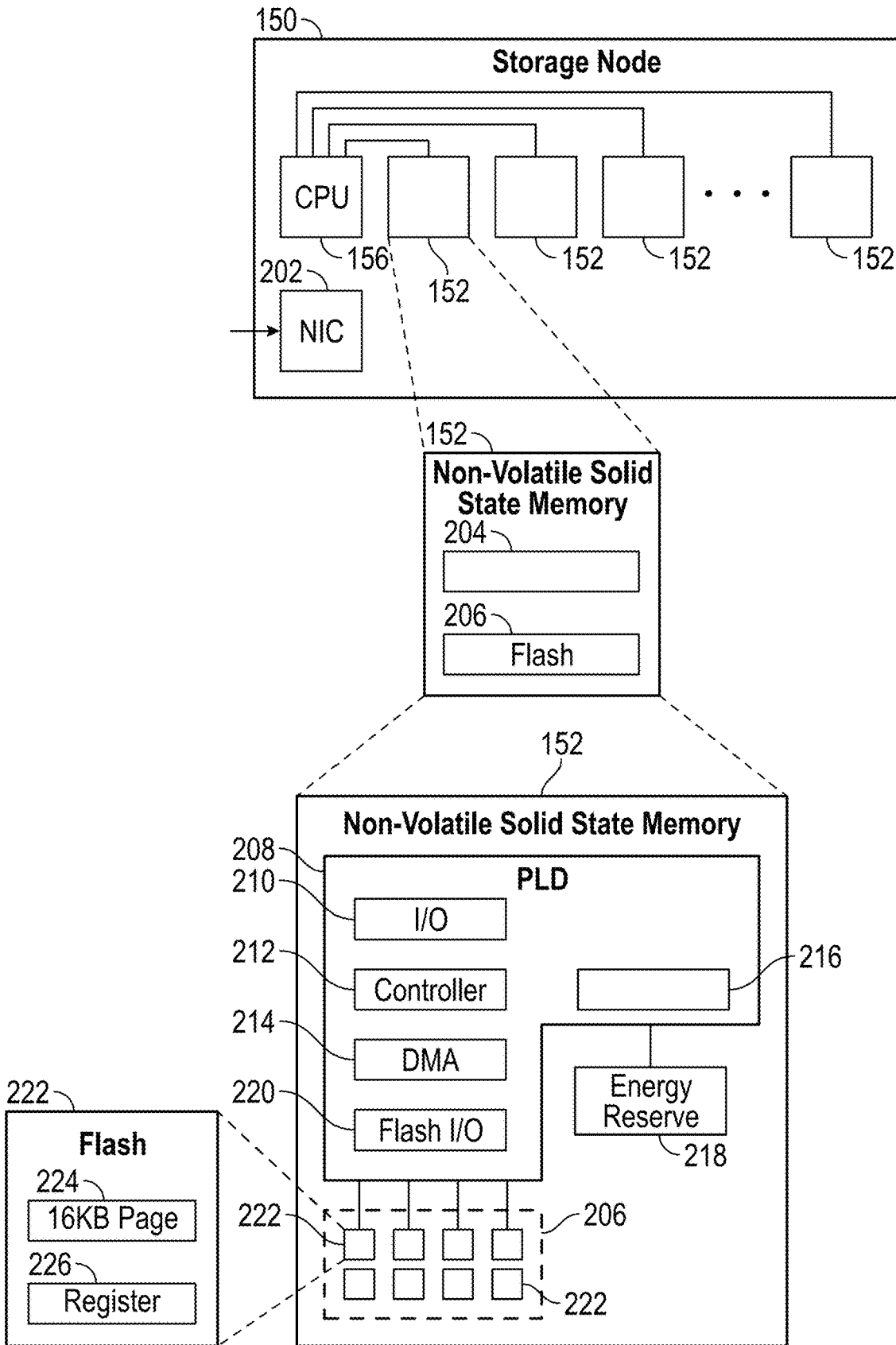

FIG. 2C

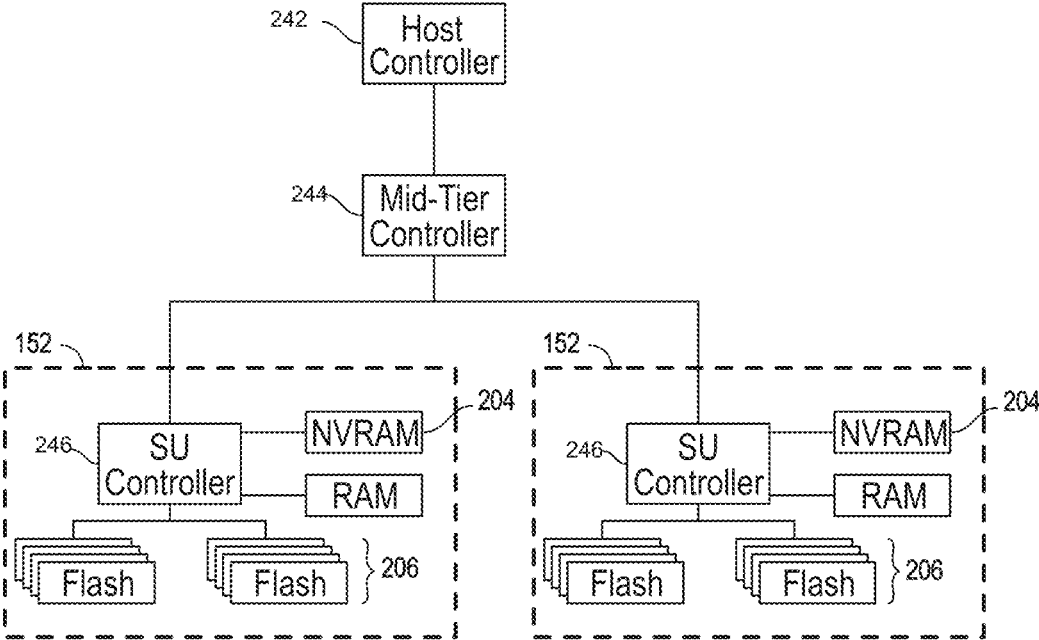

FIG. 2D

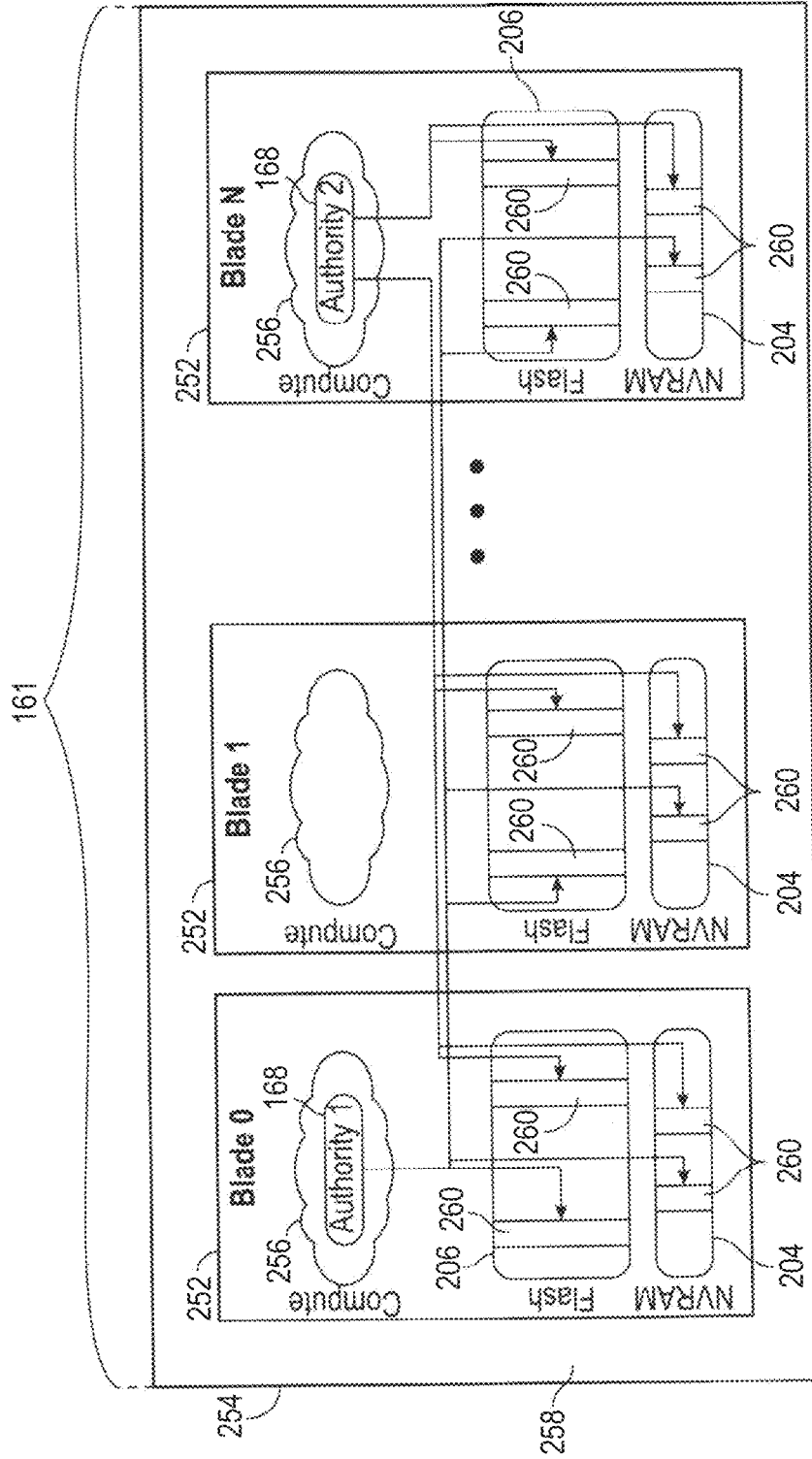

FIG. 2E

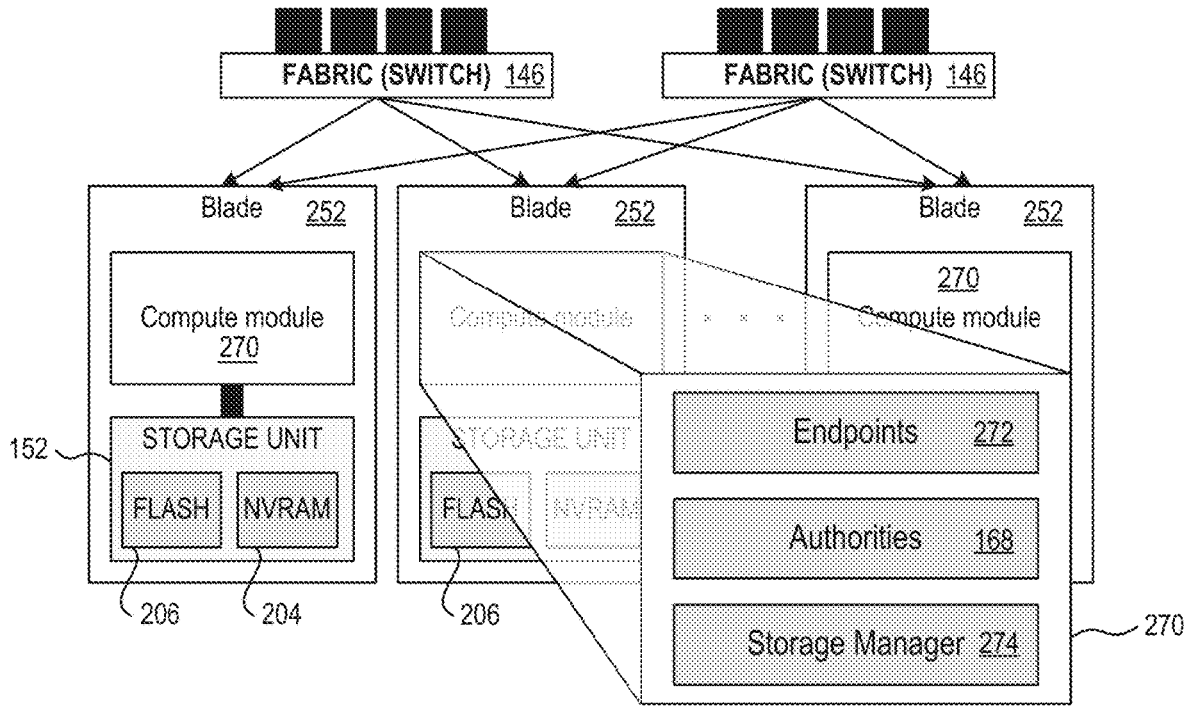

FIG. 2F

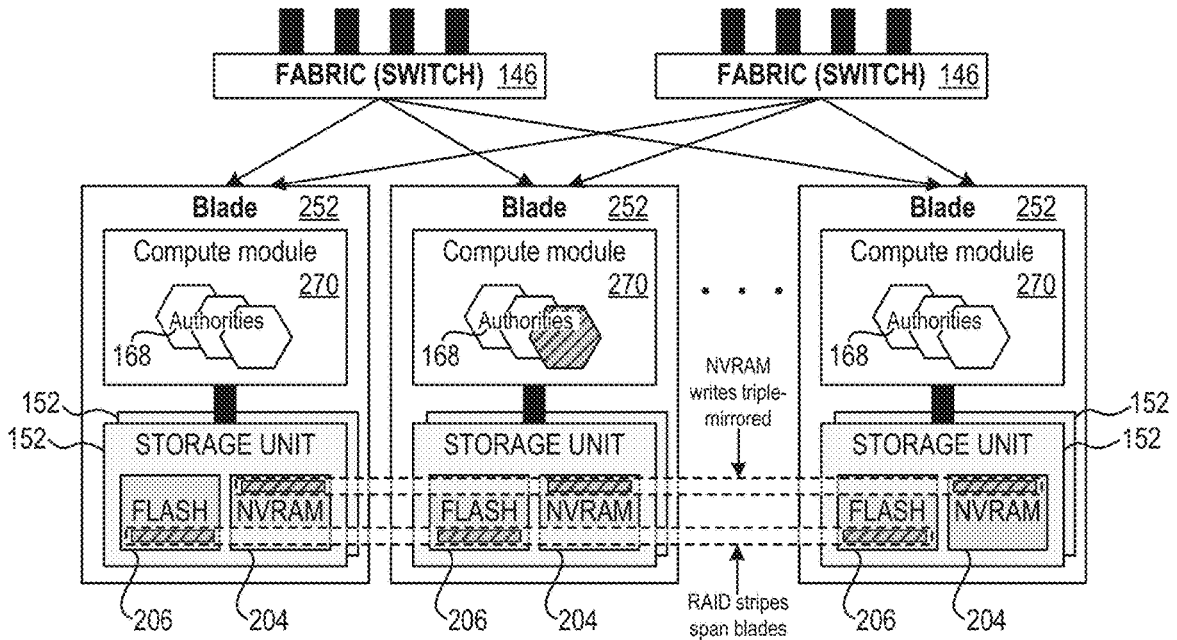

FIG. 2G

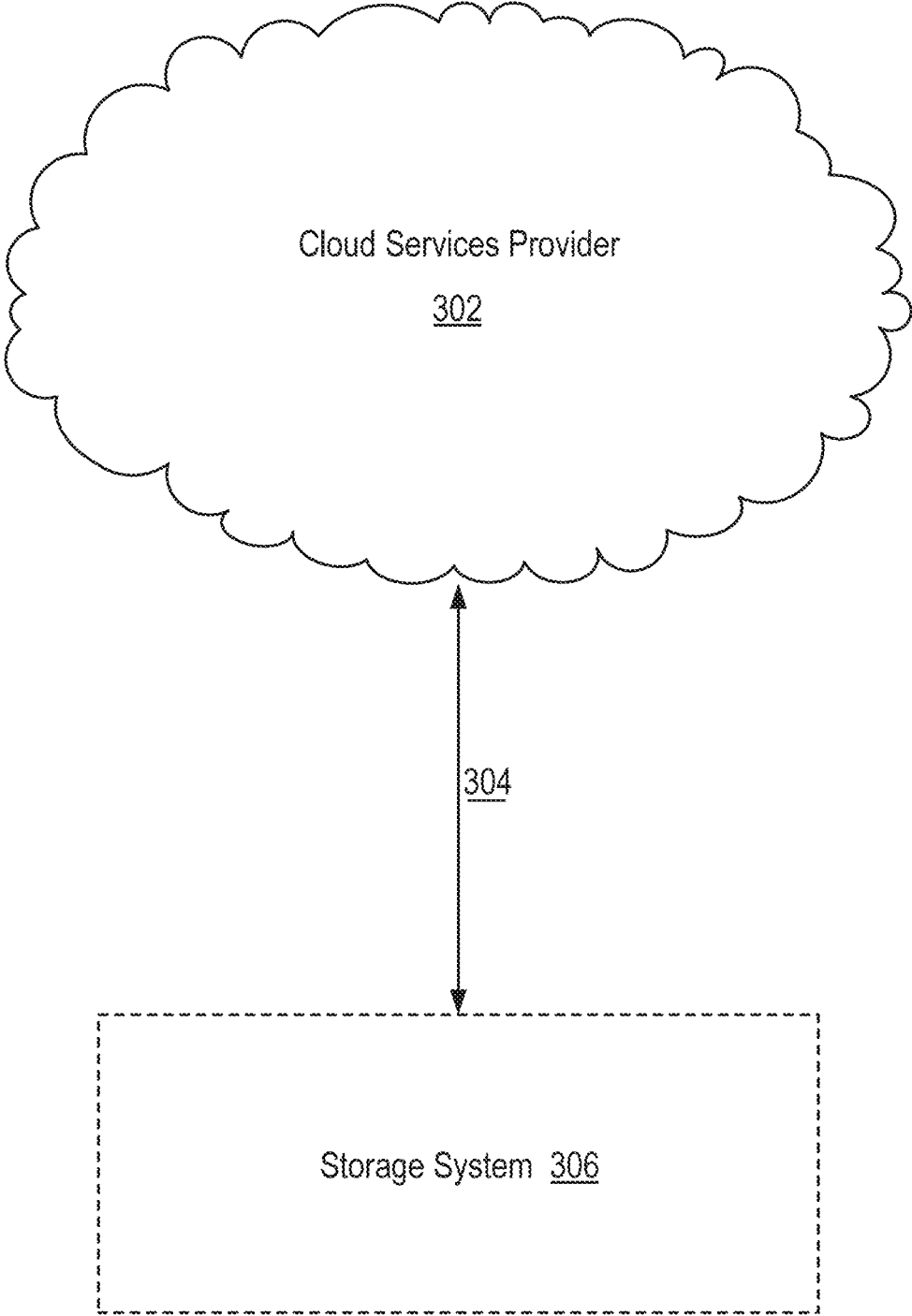

FIG. 3A

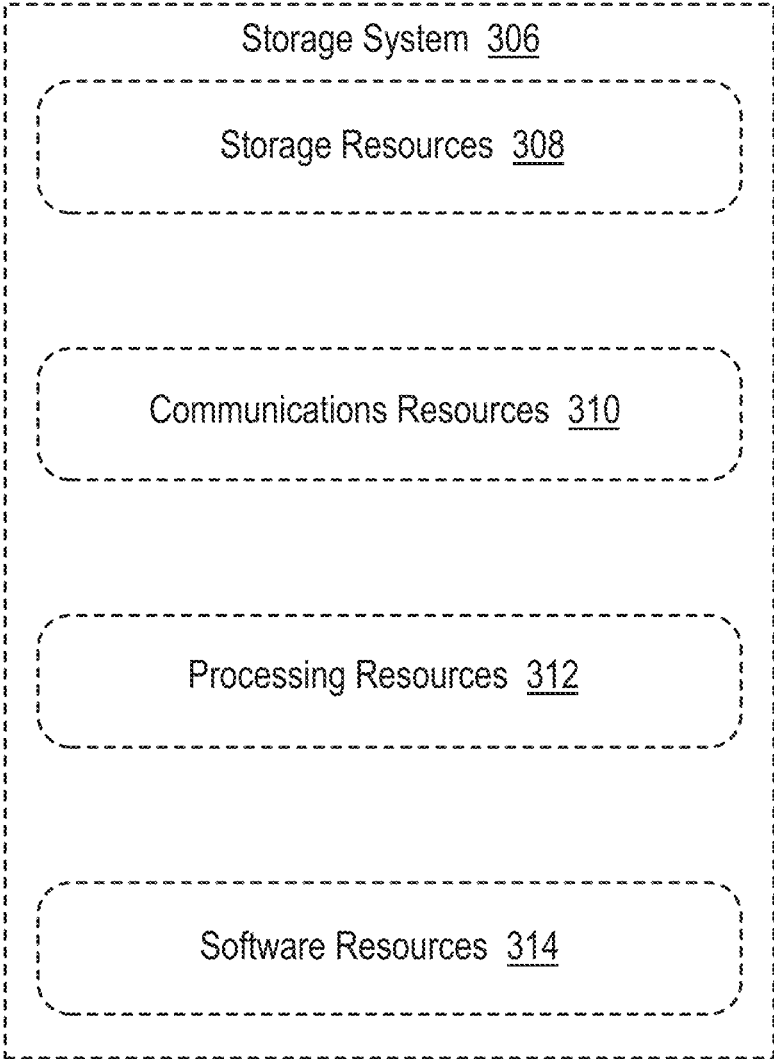

FIG. 3B

400

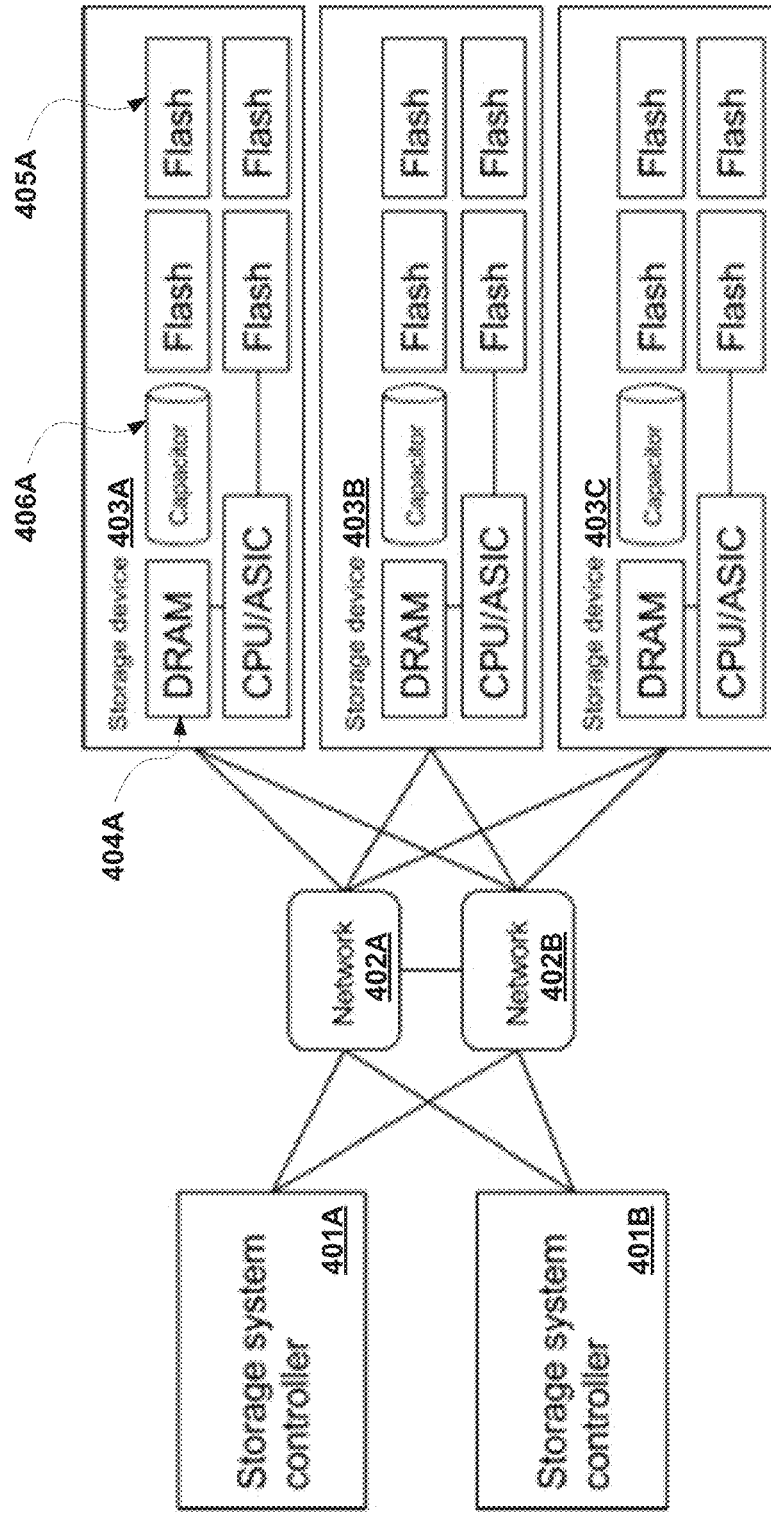

FIG. 4

500

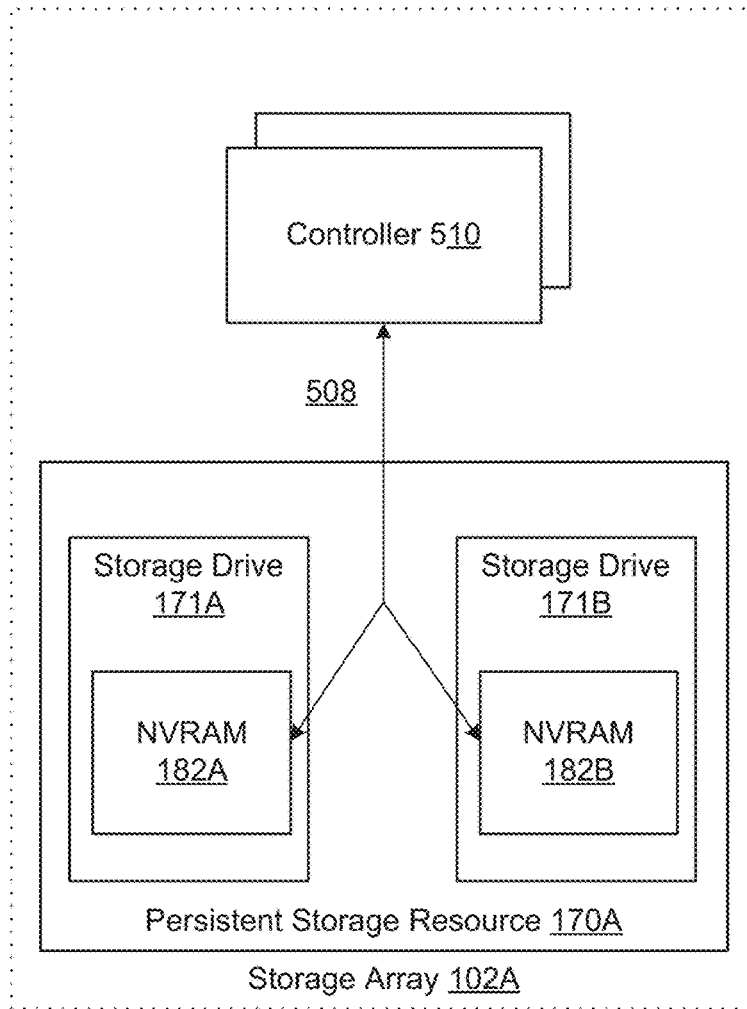

FIG. 5

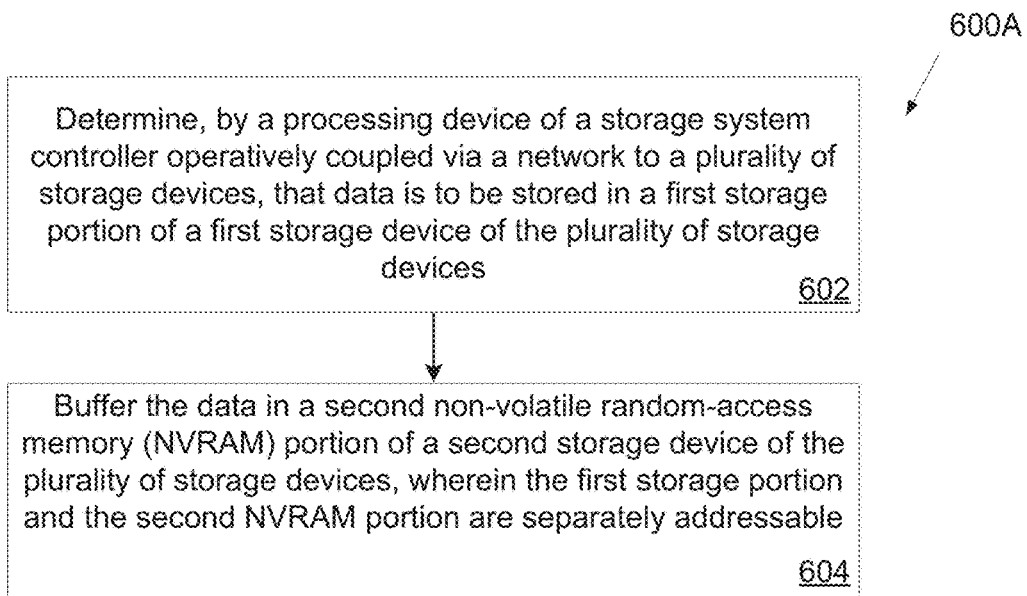

FIG. 6A

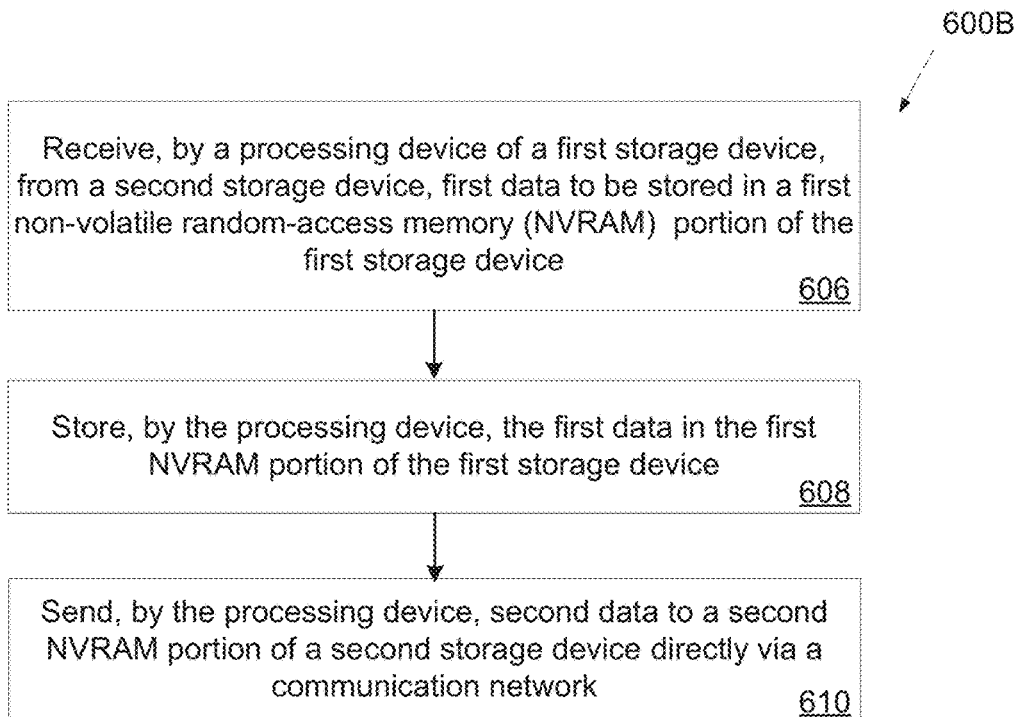

FIG. 6B

**DISTRIBUTED INTEGRATED HIGH-SPEED
SOLID-STATE NON-VOLATILE
RANDOM-ACCESS MEMORY**

RELATED APPLICATIONS

This application claims priority to U.S. Provisional Patent Application No. 62/403,899 filed Oct. 4, 2016, the entire contents of which are hereby incorporated by reference herein. This application is related to U.S. application Ser. No. 15/582,381 filed Apr. 28, 2017.

BACKGROUND

Storage systems that include flash storage drives may also include non-volatile random-access memory (NVRAM). NVRAM retains information when power is turned off, thus making it non-volatile. Solid-state drives (SSDs) in flash storage systems make use of flash memory and NVRAM to store information. Due to bandwidth limitations, however, a limited quantity of data may be written to an SSD in any given time period. NVRAM in these storage systems may be used as a buffer to temporality store information while the SSD is busy writing other data.

BRIEF DESCRIPTION OF THE DRAWINGS

The present disclosure is illustrated by way of example, and not by way of limitation, and can be more fully understood with reference to the following detailed description when considered in connection with the figures as described below.

FIG. 1A illustrates a first example system for data storage in accordance with some implementations.

FIG. 1B illustrates a second example system for data storage in accordance with some implementations.

FIG. 1C illustrates a third example system for data storage in accordance with some implementations.

FIG. 1D illustrates a fourth example system for data storage in accordance with some implementations.

FIG. 2A is a perspective view of a storage cluster with multiple storage nodes and internal storage coupled to each storage node to provide network attached storage, in accordance with some embodiments.

FIG. 2B is a block diagram showing an interconnect switch coupling multiple storage nodes in accordance with some embodiments.

FIG. 2C is a multiple level block diagram, showing contents of a storage node and contents of one of the non-volatile solid state storage units in accordance with some embodiments.

FIG. 2D shows a storage server environment, which uses embodiments of the storage nodes and storage units of FIGS. 1-3 in accordance with some embodiments.

FIG. 2E is a blade hardware block diagram, showing a control plane, compute and storage planes, and authorities interacting with underlying physical resources, in accordance with some embodiments.

FIG. 2F depicts elasticity software layers in blades of a storage cluster, in accordance with some embodiments.

FIG. 2G depicts authorities and storage resources in blades of a storage cluster, in accordance with some embodiments.

FIG. 3A sets forth a diagram of a storage system that is coupled for data communications with a cloud services provider in accordance with some embodiments of the present disclosure.

FIG. 3B sets forth a diagram of a storage system in accordance with some embodiments of the present disclosure.

FIG. 4 illustrates an example system for data storage, in accordance with some implementations.

FIG. 5 is a block diagram illustrating multiple NVRAM buffers connected via a switch, in accordance with some implementations.

FIG. 6A is a flow diagram illustrating distributed integrated high-speed solid state NVRAM operations, in accordance with some implementations.

FIG. 6B is a flow diagram illustrating direct NVRAM communication operations, in accordance with some implementations.

DETAILED DESCRIPTION

Flash memory is a solid-state, non-volatile computer storage medium that can be electrically erased and reprogrammed. Two main types of flash memory are named after NAND and NOR logic gates (e.g., NAND flash memory and NOR flash memory). Individual flash memory cells of flash memory may exhibit internal characteristics similar to those of the corresponding gates. In one implementation, memory cells may be floating gate transistors. To program the flash memory gates are filled with electrons. Erasing memory may include removing electrons from the floating gate. The amount of electrons in the gate can be measured and used to determine the value represented by the cell.

In one implementation, read and write operations to cells of an SSD containing flash memory are performed via the same data channel (e.g., SATA), and may be carried-out in cycles (e.g., read/write cycles). Data to be written that is received while flash memory is busy performing a read operation or other write operations may be queued to be written in one or more future write operations. In one implementation, a separate NVRAM buffer may be used to store data to be written in future write operations. A storage drive host may acknowledge data to be written, store it in the NVRAM, and receive an acknowledgement that the data was successfully written to the NVRAM. Advantageously, this may improve write latency for write operations. The data may later be written from the NVRAM buffer to the flash memory. In one implementation, the NVRAM buffers are external to associated SSDs and several SSD may share the same NVRAM buffer. In this implementation, NVRAM buffers may utilize a relatively large amount of physical space in a storage system. When new storage drives are added to the storage system additional NVRAM buffers also need to be added. As a result, storage systems may not efficiently scale and may have a wider array stripe leading to an increase in parity overhead.

Implementations of the present disclosure solve the above problems by including an NVRAM buffer inside individual storage drives in a storage system and allowing NVRAM buffers to communicate directly with each other via a switched network. Advantageously, by including an NVRAM buffer inside the storage drives of a storage system, less physical space in the storage system may be dedicated to NVRAM buffers, the scalability of the system may be improved, and the parity overhead decreases. Furthermore, by allowing NVRAM buffers to communicate directly with each other, network bandwidth may be reduced.

FIG. 1A illustrates an example system for data storage, in accordance with some implementations. System 100 (also referred to as "storage system" herein) includes numerous elements for purposes of illustration rather than limitation. It

may be noted that system **100** may include the same, more, or fewer elements configured in the same or different manner in other implementations.

System **100** includes a number of computing devices **164**. Computing devices (also referred to as “client devices” herein) may be for example, a server in a data center, a workstation, a personal computer, a notebook, or the like. Computing devices **164** are coupled for data communications to one or more storage arrays **102** through a storage area network (SAN) **158** or a local area network (LAN) **160**.

The SAN **158** may be implemented with a variety of data communications fabrics, devices, and protocols. For example, the fabrics for SAN **158** may include Fibre Channel, Ethernet, Infiniband, Serial Attached Small Computer System Interface (SAS), or the like. Data communications protocols for use with SAN **158** may include Advanced Technology Attachment (ATA), Fibre Channel Protocol, Small Computer System Interface (SCSI), Internet Small Computer System Interface (iSCSI), HyperSCSI, Non-Volatile Memory Express (NVMe) over Fabrics, or the like. It may be noted that SAN **158** is provided for illustration, rather than limitation. Other data communication couplings may be implemented between computing devices **164** and storage arrays **102**.

The LAN **160** may also be implemented with a variety of fabrics, devices, and protocols. For example, the fabrics for LAN **160** may include Ethernet (802.3), wireless (802.11), or the like. Data communication protocols for use in LAN **160** may include Transmission Control Protocol (TCP), User Datagram Protocol (UDP), Internet Protocol (IP), Hyper-Text Transfer Protocol (HTTP), Wireless Access Protocol (WAP), Handheld Device Transport Protocol (HDTP), Session Initiation Protocol (SIP), Real Time Protocol (RTP), or the like.

Storage arrays **102** may provide persistent data storage for the computing devices **164**. Storage array **102A** may be contained in a chassis (not shown), and storage array **102B** may be contained in another chassis (not shown), in implementations. Storage array **102A** and **102B** may include one or more storage array controllers **110** (also referred to as “controller” and “system controller” herein). A storage array controller **110** may be embodied as a module of automated computing machinery comprising computer hardware, computer software, or a combination of computer hardware and software. In some implementations, the storage array controllers **110** may be configured to carry out various storage tasks. Storage tasks may include writing data received from the computing devices **164** to storage array **102**, erasing data from storage array **102**, retrieving data from storage array **102** and providing data to computing devices **164**, monitoring and reporting of disk utilization and performance, performing redundancy operations, such as Redundant Array of Independent Drives (RAID) or RAID-like data redundancy operations, compressing data, encrypting data, and so forth.

Storage array controller **110** may be implemented in a variety of ways, including as a Field Programmable Gate Array (FPGA), a Programmable Logic Chip (PLC), an Application Specific Integrated Circuit (ASIC), System-on-Chip (SOC), or any computing device that includes discrete components such as a processing device, central processing unit, computer memory, or various adapters. Storage array controller **110** may include, for example, a data communications adapter configured to support communications via the SAN **158** or LAN **160**. In some implementations, storage array controller **110** may be independently coupled to the LAN **160**. In implementations, storage array controller **110** may include an I/O controller or the like that couples the

storage array controller **110** for data communications, through a midplane (not shown), to a persistent storage resource **170** (also referred to as a “storage resource” herein). The persistent storage resource **170** main include any number of storage drives **171** (also referred to as “storage devices” herein) and any number of non-volatile Random Access Memory (NVRAM) devices (not shown).

In some implementations, the NVRAM devices of a persistent storage resource **170** may be configured to receive, from the storage array controller **110**, data to be stored in the storage drives **171**. In some examples, the data may originate from computing devices **164**. In some examples, writing data to the NVRAM device may be carried out more quickly than directly writing data to the storage drive **171**. In implementations, the storage array controller **110** may be configured to utilize the NVRAM devices as a quickly accessible buffer for data destined to be written to the storage drives **171**. Latency for write requests using NVRAM devices as a buffer may be improved relative to a system in which a storage array controller **110** writes data directly to the storage drives **171**. In some implementations, the NVRAM devices may be implemented with computer memory in the form of high bandwidth, low latency RAM. The NVRAM device is referred to as “non-volatile” because the NVRAM device may receive or include a unique power source that maintains the state of the RAM after main power loss to the NVRAM device. Such a power source may be a battery, one or more capacitors, or the like. In response to a power loss, the NVRAM device may be configured to write the contents of the RAM to a persistent storage, such as the storage drives **171**.

In implementations, storage drive **171** may refer to any device configured to record data persistently, where “persistently” or “persistent” refers as to a device’s ability to maintain recorded data after loss of power. In some implementations, storage drive **171** may correspond to non-disk storage media. For example, the storage drive **171** may be one or more solid-state drives (SSDs), flash memory based storage, any type of solid-state non-volatile memory, or any other type of non-mechanical storage device. In other implementations, storage drive **171** may include may include mechanical or spinning hard disk, such as hard-disk drives (HDD).

In some implementations, the storage array controllers **110** may be configured for offloading device management responsibilities from storage drive **171** in storage array **102**. For example, storage array controllers **110** may manage control information that may describe the state of one or more memory blocks in the storage drives **171**. The control information may indicate, for example, that a particular memory block has failed and should no longer be written to, that a particular memory block contains boot code for a storage array controller **110**, the number of program-erase (P/E) cycles that have been performed on a particular memory block, the age of data stored in a particular memory block, and so forth. In some implementations, the control information may be stored with an associated memory block as metadata. In other implementations, the control information for the storage drives **171** may be stored in one or more particular memory blocks of the storage drives **171** that are selected by the storage array controller **110**. The selected memory blocks may be tagged with an identifier indicating that the selected memory block contains control information. The identifier may be utilized by the storage array controllers **110** in conjunction with storage drives **171** to quickly identify the memory blocks that contain control

information. For example, the storage controllers **110** may issue a command to locate memory blocks that contain control information. It may be noted that control information may be so large that parts of the control information may be stored in multiple locations, that the control information may be stored in multiple locations for purposes of redundancy, for example, or that the control information may otherwise be distributed across multiple memory blocks in the storage drive **171**.

In implementations, storage array controllers **110** may offload device management responsibilities from storage drives **171** of storage array **102** by retrieving, from the storage drives **171**, control information describing the state of one or more memory blocks in the storage drives **171**. Retrieving the control information from the storage drives **171** may be carried out, for example, by the storage array controller **110** querying the storage drives **171** for the location of control information for a particular storage drive **171**. The storage drives **171** may be configured to execute instructions that enable the storage drive **171** to identify the location of the control information. The instructions may be executed by a controller (not shown) associated with or otherwise located on the storage drive **171** and may cause the storage drive **171** to scan a portion of each memory block to identify the memory blocks that store control information for the storage drives **171**. The storage drives **171** may respond by sending a response message to the storage array controller **110** that includes the location of control information for the storage drive **171**. Responsive to receiving the response message, storage array controllers **110** may issue a request to read data stored at the address associated with the location of control information for the storage drives **171**.

In other implementations, the storage array controllers **110** may further offload device management responsibilities from storage drives **171** by performing, in response to receiving the control information, a storage drive management operation. A storage drive management operation may include, for example, an operation that is typically performed by the storage drive **171** (e.g., the controller (not shown) associated with a particular storage drive **171**). A storage drive management operation may include, for example, ensuring that data is not written to failed memory blocks within the storage drive **171**, ensuring that data is written to memory blocks within the storage drive **171** in such a way that adequate wear leveling is achieved, and so forth.

In implementations, storage array **102** may implement two or more storage array controllers **110**. For example, storage array **102A** may include storage array controllers **110A** and storage array controllers **110B**. At a given instance, a single storage array controller **110** (e.g., storage array controller **110A**) of a storage system **100** may be designated with primary status (also referred to as “primary controller” herein), and other storage array controllers **110** (e.g., storage array controller **110A**) may be designated with secondary status (also referred to as “secondary controller” herein). The primary controller may have particular rights, such as permission to alter data in persistent storage resource **170** (e.g., writing data to persistent storage resource **170**). At least some of the rights of the primary controller may supersede the rights of the secondary controller. For instance, the secondary controller may not have permission to alter data in persistent storage resource **170** when the primary controller has the right. The status of storage array controllers **110** may change. For example, storage array

controller **110A** may be designated with secondary status, and storage array controller **110B** may be designated with primary status.

In some implementations, a primary controller, such as storage array controller **110A**, may serve as the primary controller for one or more storage arrays **102**, and a second controller, such as storage array controller **110B**, may serve as the secondary controller for the one or more storage arrays **102**. For example, storage array controller **110A** may be the primary controller for storage array **102A** and storage array **102B**, and storage array controller **110B** may be the secondary controller for storage array **102A** and **102B**. In some implementations, storage array controllers **110C** and **110D** (also referred to as “storage processing modules”) may neither have primary or secondary status. Storage array controllers **110C** and **110D**, implemented as storage processing modules, may act as a communication interface between the primary and secondary controllers (e.g., storage array controllers **110A** and **110B**, respectively) and storage array **102B**. For example, storage array controller **110A** of storage array **102A** may send a write request, via SAN **158**, to storage array **102B**. The write request may be received by both storage array controllers **110C** and **110D** of storage array **102B**. Storage array controllers **110C** and **110D** facilitate the communication, e.g., send the write request to the appropriate storage drive **171**. It may be noted that in some implementations storage processing modules may be used to increase the number of storage drives controlled by the primary and secondary controllers.

In implementations, storage array controllers **110** are communicatively coupled, via a midplane (not shown), to one or more storage drives **171** and to one or more NVRAM devices (not shown) that are included as part of a storage array **102**. The storage array controllers **110** may be coupled to the midplane via one or more data communication links and the midplane may be coupled to the storage drives **171** and the NVRAM devices via one or more data communications links. The data communications links described herein are collectively illustrated by data communications links **108** and may include a Peripheral Component Interconnect Express (PCIe) bus, for example.

FIG. **1B** illustrates an example system for data storage, in accordance with some implementations. Storage array controller **101** illustrated in FIG. **1B** may be similar to the storage array controllers **110** described with respect to FIG. **1A**. In one example, storage array controller **101** may be similar to storage array controller **110A** or storage array controller **110B**. Storage array controller **101** includes numerous elements for purposes of illustration rather than limitation. It may be noted that storage array controller **101** may include the same, more, or fewer elements configured in the same or different manner in other implementations. It may be noted that elements of FIG. **1A** may be included below to help illustrate features of storage array controller **101**.

Storage array controller **101** may include one or more processing devices **104** and random access memory (RAM) **111**. Processing device **104** (or controller **101**) represents one or more general-purpose processing devices such as a microprocessor, central processing unit, or the like. More particularly, the processing device **104** (or controller **101**) may be a complex instruction set computing (CISC) microprocessor, reduced instruction set computing (RISC) microprocessor, very long instruction word (VLIW) microprocessor, or a processor implementing other instruction sets or processors implementing a combination of instruction sets. The processing device **104** (or controller **101**) may also be one or more special-purpose processing devices such as an

application specific integrated circuit (ASIC), a field programmable gate array (FPGA), a digital signal processor (DSP), network processor, or the like.

The processing device **104** may be connected to the RAM **111** via a data communications link **106**, which may be embodied as a high speed memory bus such as a Double-Data Rate 4 (DDR4) bus. Stored in RAM **111** is an operating system **112**. In some implementations, instructions **113** are stored in RAM **111**. Instructions **113** may include computer program instructions for performing operations in a direct-mapped flash storage system. In one embodiment, a direct-mapped flash storage system is one that addresses data blocks within flash drives directly and without an address translation performed by the storage controllers of the flash drives.

In implementations, storage array controller **101** includes one or more host bus adapters **103** that are coupled to the processing device **104** via a data communications link **105**. In implementations, host bus adapters **103** may be computer hardware that connects a host system (e.g., the storage array controller) to other network and storage arrays. In some examples, host bus adapters **103** may be a Fibre Channel adapter that enables the storage array controller **101** to connect to a SAN, an Ethernet adapter that enables the storage array controller **101** to connect to a LAN, or the like. Host bus adapters **103** may be coupled to the processing device **104** via a data communications link **105** such as, for example, a PCIe bus.

In implementations, storage array controller **101** may include a host bus adapter **114** that is coupled to an expander **115**. The expander **115** may be used to attach a host system to a larger number of storage drives. The expander **115** may, for example, be a SAS expander utilized to enable the host bus adapter **114** to attach to storage drives in an implementation where the host bus adapter **114** is embodied as a SAS controller.

In implementations, storage array controller **101** may include a switch **116** coupled to the processing device **104** via a data communications link **109**. The switch **116** may be a computer hardware device that can create multiple endpoints out of a single endpoint, thereby enabling multiple devices to share a single endpoint. The switch **116** may, for example, be a PCIe switch that is coupled to a PCIe bus (e.g., data communications link **109**) and presents multiple PCIe connection points to the midplane.

In implementations, storage array controller **101** includes a data communications link **107** for coupling the storage array controller **101** to other storage array controllers. In some examples, data communications link **107** may be a QuickPath Interconnect (QPI) interconnect.

A traditional storage system that uses traditional flash drives may implement a process across the flash drives that are part of the traditional storage system. For example, a higher level process of the storage system may initiate and control a process across the flash drives. However, a flash drive of the traditional storage system may include its own storage controller that also performs the process. Thus, for the traditional storage system, a higher level process (e.g., initiated by the storage system) and a lower level process (e.g., initiated by a storage controller of the storage system) may both be performed.

To resolve various deficiencies of a traditional storage system, operations may be performed by higher level processes and not by the lower level processes. For example, the flash storage system may include flash drives that do not include storage controllers that provide the process. Thus, the operating system of the flash storage system itself may

initiate and control the process. This may be accomplished by a direct-mapped flash storage system that addresses data blocks within the flash drives directly and without an address translation performed by the storage controllers of the flash drives.

The operating system of the flash storage system may identify and maintain a list of allocation units across multiple flash drives of the flash storage system. The allocation units may be entire erase blocks or multiple erase blocks. The operating system may maintain a map or address range that directly maps addresses to erase blocks of the flash drives of the flash storage system.

Direct mapping to the erase blocks of the flash drives may be used to rewrite data and erase data. For example, the operations may be performed on one or more allocation units that include a first data and a second data where the first data is to be retained and the second data is no longer being used by the flash storage system. The operating system may initiate the process to write the first data to new locations within other allocation units and erasing the second data and marking the allocation units as being available for use for subsequent data. Thus, the process may only be performed by the higher level operating system of the flash storage system without an additional lower level process being performed by controllers of the flash drives.

Advantages of the process being performed only by the operating system of the flash storage system include increased reliability of the flash drives of the flash storage system as unnecessary or redundant write operations are not being performed during the process. One possible point of novelty here is the concept of initiating and controlling the process at the operating system of the flash storage system. In addition, the process can be controlled by the operating system across multiple flash drives. This is contrast to the process being performed by a storage controller of a flash drive.

A storage system can consist of two storage array controllers that share a set of drives for failover purposes, or it could consist of a single storage array controller that provides a storage service that utilizes multiple drives, or it could consist of a distributed network of storage array controllers each with some number of drives or some amount of Flash storage where the storage array controllers in the network collaborate to provide a complete storage service and collaborate on various aspects of a storage service including storage allocation and garbage collection.

FIG. 1C illustrates a third example system **117** for data storage in accordance with some implementations. System **117** (also referred to as "storage system" herein) includes numerous elements for purposes of illustration rather than limitation. It may be noted that system **117** may include the same, more, or fewer elements configured in the same or different manner in other implementations.

In one embodiment, system **117** includes a dual Peripheral Component Interconnect (PCI) flash storage device **118** with separately addressable fast write storage. System **117** may include a storage controller **119**. In one embodiment, storage controller **119** may be a CPU, ASIC, FPGA, or any other circuitry that may implement control structures necessary according to the present disclosure. In one embodiment, system **117** includes flash memory devices (e.g., including flash memory devices **120a-n**), operatively coupled to various channels of the storage device controller **119**. Flash memory devices **120a-n**, may be presented to the controller **119** as an addressable collection of Flash pages, erase blocks, and/or control elements sufficient to allow the storage device controller **119** to program and retrieve various

aspects of the Flash. In one embodiment, storage device controller **119** may perform operations on flash memory devices **120A-N** including storing and retrieving data content of pages, arranging and erasing any blocks, tracking statistics related to the use and reuse of Flash memory pages, erase blocks, and cells, tracking and predicting error codes and faults within the Flash memory, controlling voltage levels associated with programming and retrieving contents of Flash cells, etc.

In one embodiment, system **117** may include random access memory (RAM) **121** to store separately addressable fast-write data. In one embodiment, RAM **121** may be one or more separate discrete devices. In another embodiment, RAM **121** may be integrated into storage device controller **119** or multiple storage device controllers. The RAM **121** may be utilized for other purposes as well, such as temporary program memory for a processing device (E.g., a central processing unit (CPU)) in the storage device controller **119**.

In one embodiment, system **119** may include a stored energy device **122**, such as a rechargeable battery or a capacitor. Stored energy device **122** may store energy sufficient to power the storage device controller **119**, some amount of the RAM (e.g., RAM **121**), and some amount of Flash memory (e.g., Flash memory **120a-120n**) for sufficient time to write the contents of RAM to Flash memory. In one embodiment, storage device controller **119** may write the contents of RAM to Flash Memory if the storage device controller detects loss of external power.

In one embodiment, system **117** includes two data communications links **123a**, **123b**. In one embodiment, data communications links **123a**, **123b** may be PCI interfaces. In another embodiment, data communications links **123a**, **123b** may be based on other communications standards (e.g., HyperTransport, InfiBand, etc.). Data communications links **123a**, **123b** may be based on non-volatile memory express (NVMe) or NCMe over fabrics (NVMf) specifications that allow external connection to the storage device controller **119** from other components in the storage system **117**. It should be noted that data communications links may be interchangeably referred to herein as PCI buses for convenience.

System **117** may also include an external power source (not shown), which may be provided over one or both data communications links **123a**, **123b**, or which may be provided separately. An alternative embodiment includes a separate Flash memory (not shown) dedicated for use in storing the content of RAM **121**. The storage device controller **119** may present a logical device over a PCI bus which may include an addressable fast-write logical device, or a distinct part of the logical address space of the storage device **118**, which may be presented as PCI memory or as persistent storage. In one embodiment, operations to store into the device are directed into the RAM **121**. On power failure, the storage device controller **119** may write stored content associated with the addressable fast-write logical storage to Flash memory (e.g., Flash memory **120a-n**) for long-term persistent storage.

In one embodiment, the logical device may include some presentation of some or all of the content of the Flash memory devices **120a-n**, where that presentation allows a storage system including a storage device **118** (e.g., storage system **117**) to directly address Flash memory pages and directly reprogram erase blocks from storage system components that are external to the storage device through the PCI bus. The presentation may also allow one or more of the external components to control and retrieve other aspects of the Flash memory including some or all of: tracking statis-

tics related to use and reuse of Flash memory pages, erase blocks, and cells across all the Flash memory devices; tracking and predicting error codes and faults within and across the Flash memory devices; controlling voltage levels associated with programming and retrieving contents of Flash cells; etc.

In one embodiment, the stored energy device **122** may be sufficient to ensure completion of in-progress operations to the Flash memory devices **107a-120n** stored energy device **122** may power storage device controller **119** and associated Flash memory devices (e.g., **120a-n**) for those operations, as well as for the storing of fast-write RAM to Flash memory. Stored energy device **122** may be used to store accumulated statistics and other parameters kept and tracked by the Flash memory devices **120a-n** and/or the storage device controller **119**. Separate capacitors or stored energy devices (such as smaller capacitors near or embedded within the Flash memory devices themselves) may be used for some or all of the operations described herein.

Various schemes may be used to track and optimize the life span of the stored energy component, such as adjusting voltage levels over time, partially discharging the storage energy device **122** to measure corresponding discharge characteristics, etc. If the available energy decreases over time, the effective available capacity of the addressable fast-write storage may be decreased to ensure that it can be written safely based on the currently available stored energy.

FIG. 1D illustrates a third example system **124** for data storage in accordance with some implementations. In one embodiment, system **124** includes storage controllers **125a**, **125b**. In one embodiment, storage controllers **125a**, **125b** are operatively coupled to Dual PCI storage devices **119a**, **119b** and **119c**, **119d**, respectively. Storage controllers **125a**, **125b** may be operatively coupled (e.g., via a storage network **130**) to some number of host computers **127a-n**.

In one embodiment, two storage controllers (e.g., **125a** and **125b**) provide storage services, such as a small computer system interface (SCSI) block storage array, a file server, an object server, a database or data analytics service, etc. The storage controllers **125a**, **125b** may provide services through some number of network interfaces (e.g., **126a-d**) to host computers **127a-n** outside of the storage system **124**. Storage controllers **125a**, **125b** may provide integrated services or an application entirely within the storage system **124**, forming a converged storage and compute system. The storage controllers **125a**, **125b** may utilize the fast write memory within or across storage devices **119a-d** to journal in progress operations to ensure the operations are not lost on a power failure, storage controller removal, storage controller or storage system shutdown, or some fault of one or more software or hardware components within the storage system **124**.

In one embodiment, controllers **125a**, **125b** operate as PCI masters to one or the other PCI buses **128a**, **128b**. In another embodiment, **128a** and **128b** may be based on other communications standards (e.g., HyperTransport, InfiBand, etc.). Other storage system embodiments may operate storage controllers **125a**, **125b** as multi-masters for both PCI buses **128a**, **128b**. Alternately, a PCI/NVMe/NVMf switching infrastructure or fabric may connect multiple storage controllers. Some storage system embodiments may allow storage devices to communicate with each other directly rather than communicating only with storage controllers. In one embodiment, a storage device controller **119a** may be operable under direction from a storage controller **125a** to synthesize and transfer data to be stored into Flash memory devices from data that has been stored in RAM (e.g., RAM

121 of FIG. 1C). For example, a recalculated version of RAM content may be transferred after a storage controller has determined that an operation has fully committed across the storage system, or when fast-write memory on the device has reached a certain used capacity, or after a certain amount of time, to ensure improve safety of the data or to release addressable fast-write capacity for reuse. This mechanism may be used, for example, to avoid a second transfer over a bus (e.g., 128a, 128b) from the storage controllers 125a, 125b. In one embodiment, a recalculation may include compressing data, attaching indexing or other metadata, combining multiple data segments together, performing erasure code calculations, etc.

In one embodiment, under direction from a storage controller 125a, 125b, a storage device controller 119a, 119b may be operable to calculate and transfer data to other storage devices from data stored in RAM (e.g., RAM 121 of FIG. 1C) without involvement of the storage controllers 125a, 125b. This operation may be used to mirror data stored in one controller 125a to another controller 125b, or it could be used to offload compression, data aggregation, and/or erasure coding calculations and transfers to storage devices to reduce load on storage controllers or the storage controller interface 129a, 129b to the PCI bus 128a, 128b.

A storage device controller 119 may include mechanisms for implementing high availability primitives for use by other parts of a storage system external to the Dual PCI storage device 118. For example, reservation or exclusion primitives may be provided so that, in a storage system with two storage controllers providing a highly available storage service, one storage controller may prevent the other storage controller from accessing or continuing to access the storage device. This could be used, for example, in cases where one controller detects that the other controller is not functioning properly or where the interconnect between the two storage controllers may itself not be functioning properly.

In one embodiment, a storage system for use with Dual PCI direct mapped storage devices with separately addressable fast write storage includes systems that manage erase blocks or groups of erase blocks as allocation units for storing data on behalf of the storage service, or for storing metadata (e.g., indexes, logs, etc.) associated with the storage service, or for proper management of the storage system itself. Flash pages, which may be a few kilobytes in size, may be written as data arrives or as the storage system is to persist data for long intervals of time (e.g., above a defined threshold of time). To commit data more quickly, or to reduce the number of writes to the Flash memory devices, the storage controllers may first write data into the separately addressable fast write storage on one more storage devices.

In one embodiment, the storage controllers 125a, 125b may initiate the use of erase blocks within and across storage devices (e.g., 118) in accordance with an age and expected remaining lifespan of the storage devices, or based on other statistics. The storage controllers 125a, 125b may initiate garbage collection and data migration data between storage devices in accordance with pages that are no longer needed as well as to manage Flash page and erase block lifespans and to manage overall system performance.

In one embodiment, the storage system 124 may utilize mirroring and/or erasure coding schemes as part of storing data into addressable fast write storage and/or as part of writing data into allocation units associated with erase blocks. Erasure codes may be used across storage devices, as well as within erase blocks or allocation units, or within and across Flash memory devices on a single storage device, to

provide redundancy against single or multiple storage device failures or to protect against internal corruptions of Flash memory pages resulting from Flash memory operations or from degradation of Flash memory cells. Mirroring and erasure coding at various levels may be used to recover from multiple types of failures that occur separately or in combination.

The embodiments depicted with reference to FIGS. 2A-G illustrate a storage cluster that stores user data, such as user data originating from one or more user or client systems or other sources external to the storage cluster. The storage cluster distributes user data across storage nodes housed within a chassis, or across multiple chassis, using erasure coding and redundant copies of metadata. Erasure coding refers to a method of data protection or reconstruction in which data is stored across a set of different locations, such as disks, storage nodes or geographic locations. Flash memory is one type of solid-state memory that may be integrated with the embodiments, although the embodiments may be extended to other types of solid-state memory or other storage medium, including non-solid state memory. Control of storage locations and workloads are distributed across the storage locations in a clustered peer-to-peer system. Tasks such as mediating communications between the various storage nodes, detecting when a storage node has become unavailable, and balancing I/Os (inputs and outputs) across the various storage nodes, are all handled on a distributed basis. Data is laid out or distributed across multiple storage nodes in data fragments or stripes that support data recovery in some embodiments. Ownership of data can be reassigned within a cluster, independent of input and output patterns. This architecture described in more detail below allows a storage node in the cluster to fail, with the system remaining operational, since the data can be reconstructed from other storage nodes and thus remain available for input and output operations. In various embodiments, a storage node may be referred to as a cluster node, a blade, or a server.

The storage cluster may be contained within a chassis, i.e., an enclosure housing one or more storage nodes. A mechanism to provide power to each storage node, such as a power distribution bus, and a communication mechanism, such as a communication bus that enables communication between the storage nodes are included within the chassis. The storage cluster can run as an independent system in one location according to some embodiments. In one embodiment, a chassis contains at least two instances of both the power distribution and the communication bus which may be enabled or disabled independently. The internal communication bus may be an Ethernet bus, however, other technologies such as Peripheral Component Interconnect (PCI) Express, InfiniBand, and others, are equally suitable. The chassis provides a port for an external communication bus for enabling communication between multiple chassis, directly or through a switch, and with client systems. The external communication may use a technology such as Ethernet, InfiniBand, Fibre Channel, etc. In some embodiments, the external communication bus uses different communication bus technologies for inter-chassis and client communication. If a switch is deployed within or between chassis, the switch may act as a translation between multiple protocols or technologies. When multiple chassis are connected to define a storage cluster, the storage cluster may be accessed by a client using either proprietary interfaces or standard interfaces such as network file system (NFS), common internet file system (CIFS), small computer system interface (SCSI) or hypertext transfer protocol (HTTP).

13

Translation from the client protocol may occur at the switch, chassis external communication bus or within each storage node. In some embodiments, multiple chassis may be coupled or connected to each other through an aggregator switch. A portion and/or all of the coupled or connected chassis may be designated as a storage cluster. As discussed above, each chassis can have multiple blades, each blade has a MAC (media access control) address, but the storage cluster is presented to an external network as having a single cluster IP (Internet Protocol) address and a single MAC address in some embodiments.

Each storage node may be one or more storage servers and each storage server is connected to one or more non-volatile solid state memory units, which may be referred to as storage units or storage devices. One embodiment includes a single storage server in each storage node and between one to eight non-volatile solid state memory units, however this one example is not meant to be limiting. The storage server may include a processor, dynamic random access memory (DRAM) and interfaces for the internal communication bus and power distribution for each of the power buses. Inside the storage node, the interfaces and storage unit share a communication bus, e.g., PCI Express, in some embodiments. The non-volatile solid state memory units may directly access the internal communication bus interface through a storage node communication bus, or request the storage node to access the bus interface. The non-volatile solid state memory unit contains an embedded central processing unit (CPU), solid state storage controller, and a quantity of solid state mass storage, e.g., between 2-32 terabytes (TB) in some embodiments. An embedded volatile storage medium, such as DRAM, and an energy reserve apparatus are included in the non-volatile solid state memory unit. In some embodiments, the energy reserve apparatus is a capacitor, super-capacitor, or battery that enables transferring a subset of DRAM contents to a stable storage medium in the case of power loss. In some embodiments, the non-volatile solid state memory unit is constructed with a storage class memory, such as phase change or magnetoresistive random access memory (MRAM) that substitutes for DRAM and enables a reduced power hold-up apparatus.

One of many features of the storage nodes and non-volatile solid state storage is the ability to proactively rebuild data in a storage cluster. The storage nodes and non-volatile solid state storage can determine when a storage node or non-volatile solid state storage in the storage cluster is unreachable, independent of whether there is an attempt to read data involving that storage node or non-volatile solid state storage. The storage nodes and non-volatile solid state storage then cooperate to recover and rebuild the data in at least partially new locations. This constitutes a proactive rebuild, in that the system rebuilds data without waiting until the data is needed for a read access initiated from a client system employing the storage cluster. These and further details of the storage memory and operation thereof are discussed below.

FIG. 2A is a perspective view of a storage cluster 161, with multiple storage nodes 150 and internal solid-state memory coupled to each storage node to provide network attached storage or storage area network, in accordance with some embodiments. A network attached storage, storage area network, or a storage cluster, or other storage memory, could include one or more storage clusters 161, each having one or more storage nodes 150, in a flexible and reconfigurable arrangement of both the physical components and the amount of storage memory provided thereby. The storage

14

cluster 161 is designed to fit in a rack, and one or more racks can be set up and populated as desired for the storage memory. The storage cluster 161 has a chassis 138 having multiple slots 142. It should be appreciated that chassis 138 may be referred to as a housing, enclosure, or rack unit. In one embodiment, the chassis 138 has fourteen slots 142, although other numbers of slots are readily devised. For example, some embodiments have four slots, eight slots, sixteen slots, thirty-two slots, or other suitable number of slots. Each slot 142 can accommodate one storage node 150 in some embodiments. Chassis 138 includes flaps 148 that can be utilized to mount the chassis 138 on a rack. Fans 144 provide air circulation for cooling of the storage nodes 150 and components thereof, although other cooling components could be used, or an embodiment could be devised without cooling components. A switch fabric 146 couples storage nodes 150 within chassis 138 together and to a network for communication to the memory. In an embodiment depicted in FIG. 1, the slots 142 to the left of the switch fabric 146 and fans 144 are shown occupied by storage nodes 150, while the slots 142 to the right of the switch fabric 146 and fans 144 are empty and available for insertion of storage node 150 for illustrative purposes. This configuration is one example, and one or more storage nodes 150 could occupy the slots 142 in various further arrangements. The storage node arrangements need not be sequential or adjacent in some embodiments. Storage nodes 150 are hot pluggable, meaning that a storage node 150 can be inserted into a slot 142 in the chassis 138, or removed from a slot 142, without stopping or powering down the system. Upon insertion or removal of storage node 150 from slot 142, the system automatically reconfigures in order to recognize and adapt to the change. Reconfiguration, in some embodiments, includes restoring redundancy and/or rebalancing data or load.

Each storage node 150 can have multiple components. In the embodiment shown here, the storage node 150 includes a printed circuit board 159 populated by a CPU 156, i.e., processor, a memory 154 coupled to the CPU 156, and a non-volatile solid state storage 152 coupled to the CPU 156, although other mountings and/or components could be used in further embodiments. The memory 154 has instructions which are executed by the CPU 156 and/or data operated on by the CPU 156. As further explained below, the non-volatile solid state storage 152 includes flash or, in further embodiments, other types of solid-state memory.

Referring to FIG. 2A, storage cluster 161 is scalable, meaning that storage capacity with non-uniform storage sizes is readily added, as described above. One or more storage nodes 150 can be plugged into or removed from each chassis and the storage cluster self-configures in some embodiments. Plug-in storage nodes 150, whether installed in a chassis as delivered or later added, can have different sizes. For example, in one embodiment a storage node 150 can have any multiple of 4 TB, e.g., 8 TB, 12 TB, 16 TB, 32 TB, etc. In further embodiments, a storage node 150 could have any multiple of other storage amounts or capacities. Storage capacity of each storage node 150 is broadcast, and influences decisions of how to stripe the data. For maximum storage efficiency, an embodiment can self-configure as wide as possible in the stripe, subject to a predetermined requirement of continued operation with loss of up to one, or up to two, non-volatile solid state storage units 152 or storage nodes 150 within the chassis.

FIG. 2B is a block diagram showing a communications interconnect 171 and power distribution bus 172 coupling multiple storage nodes 150. Referring back to FIG. 2A, the

communications interconnect **171** can be included in or implemented with the switch fabric **146** in some embodiments. Where multiple storage clusters **161** occupy a rack, the communications interconnect **171** can be included in or implemented with a top of rack switch, in some embodiments. As illustrated in FIG. 2B, storage cluster **161** is enclosed within a single chassis **138**. External port **176** is coupled to storage nodes **150** through communications interconnect **171**, while external port **174** is coupled directly to a storage node. External power port **178** is coupled to power distribution bus **172**. Storage nodes **150** may include varying amounts and differing capacities of non-volatile solid state storage **152** as described with reference to FIG. 2A. In addition, one or more storage nodes **150** may be a compute only storage node as illustrated in FIG. 2B. Authorities **168** are implemented on the non-volatile solid state storages **152**, for example as lists or other data structures stored in memory. In some embodiments the authorities are stored within the non-volatile solid state storage **152** and supported by software executing on a controller or other processor of the non-volatile solid state storage **152**. In a further embodiment, authorities **168** are implemented on the storage nodes **150**, for example as lists or other data structures stored in the memory **154** and supported by software executing on the CPU **156** of the storage node **150**. Authorities **168** control how and where data is stored in the non-volatile solid state storages **152** in some embodiments. This control assists in determining which type of erasure coding scheme is applied to the data, and which storage nodes **150** have which portions of the data. Each authority **168** may be assigned to a non-volatile solid state storage **152**. Each authority may control a range of inode numbers, segment numbers, or other data identifiers which are assigned to data by a file system, by the storage nodes **150**, or by the non-volatile solid state storage **152**, in various embodiments.

Every piece of data, and every piece of metadata, has redundancy in the system in some embodiments. In addition, every piece of data and every piece of metadata has an owner, which may be referred to as an authority. If that authority is unreachable, for example through failure of a storage node, there is a plan of succession for how to find that data or that metadata. In various embodiments, there are redundant copies of authorities **168**. Authorities **168** have a relationship to storage nodes **150** and non-volatile solid state storage **152** in some embodiments. Each authority **168**, covering a range of data segment numbers or other identifiers of the data, may be assigned to a specific non-volatile solid state storage **152**. In some embodiments the authorities **168** for all of such ranges are distributed over the non-volatile solid state storages **152** of a storage cluster. Each storage node **150** has a network port that provides access to the non-volatile solid state storage(s) **152** of that storage node **150**. Data can be stored in a segment, which is associated with a segment number and that segment number is an indirection for a configuration of a RAID (redundant array of independent disks) stripe in some embodiments. The assignment and use of the authorities **168** thus establishes an indirection to data. Indirection may be referred to as the ability to reference data indirectly, in this case via an authority **168**, in accordance with some embodiments. A segment identifies a set of non-volatile solid state storage **152** and a local identifier into the set of non-volatile solid state storage **152** that may contain data. In some embodiments, the local identifier is an offset into the device and may be reused sequentially by multiple segments. In other embodiments the local identifier is unique for a specific segment and never reused. The offsets in the non-volatile

solid state storage **152** are applied to locating data for writing to or reading from the non-volatile solid state storage **152** (in the form of a RAID stripe). Data is striped across multiple units of non-volatile solid state storage **152**, which may include or be different from the non-volatile solid state storage **152** having the authority **168** for a particular data segment.

If there is a change in where a particular segment of data is located, e.g., during a data move or a data reconstruction, the authority **168** for that data segment should be consulted, at that non-volatile solid state storage **152** or storage node **150** having that authority **168**. In order to locate a particular piece of data, embodiments calculate a hash value for a data segment or apply an inode number or a data segment number. The output of this operation points to a non-volatile solid state storage **152** having the authority **168** for that particular piece of data. In some embodiments there are two stages to this operation. The first stage maps an entity identifier (ID), e.g., a segment number, inode number, or directory number to an authority identifier. This mapping may include a calculation such as a hash or a bit mask. The second stage is mapping the authority identifier to a particular non-volatile solid state storage **152**, which may be done through an explicit mapping. The operation is repeatable, so that when the calculation is performed, the result of the calculation repeatably and reliably points to a particular non-volatile solid state storage **152** having that authority **168**. The operation may include the set of reachable storage nodes as input. If the set of reachable non-volatile solid state storage units changes the optimal set changes. In some embodiments, the persisted value is the current assignment (which is always true) and the calculated value is the target assignment the cluster will attempt to reconfigure towards. This calculation may be used to determine the optimal non-volatile solid state storage **152** for an authority in the presence of a set of non-volatile solid state storage **152** that are reachable and constitute the same cluster. The calculation also determines an ordered set of peer non-volatile solid state storage **152** that will also record the authority to non-volatile solid state storage mapping so that the authority may be determined even if the assigned non-volatile solid state storage is unreachable. A duplicate or substitute authority **168** may be consulted if a specific authority **168** is unavailable in some embodiments.

With reference to FIGS. 2A and 2B, two of the many tasks of the CPU **156** on a storage node **150** are to break up write data, and reassemble read data. When the system has determined that data is to be written, the authority **168** for that data is located as above. When the segment ID for data is already determined the request to write is forwarded to the non-volatile solid state storage **152** currently determined to be the host of the authority **168** determined from the segment. The host CPU **156** of the storage node **150**, on which the non-volatile solid state storage **152** and corresponding authority **168** reside, then breaks up or shards the data and transmits the data out to various non-volatile solid state storage **152**. The transmitted data is written as a data stripe in accordance with an erasure coding scheme. In some embodiments, data is requested to be pulled, and in other embodiments, data is pushed. In reverse, when data is read, the authority **168** for the segment ID containing the data is located as described above. The host CPU **156** of the storage node **150** on which the non-volatile solid state storage **152** and corresponding authority **168** reside requests the data from the non-volatile solid state storage and corresponding storage nodes pointed to by the authority. In some embodiments the data is read from flash storage as a data stripe. The

host CPU **156** of storage node **150** then reassembles the read data, correcting any errors (if present) according to the appropriate erasure coding scheme, and forwards the reassembled data to the network. In further embodiments, some or all of these tasks can be handled in the non-volatile solid state storage **152**. In some embodiments, the segment host requests the data be sent to storage node **150** by requesting pages from storage and then sending the data to the storage node making the original request.

In some systems, for example in UNIX-style file systems, data is handled with an index node or inode, which specifies a data structure that represents an object in a file system. The object could be a file or a directory, for example. Metadata may accompany the object, as attributes such as permission data and a creation timestamp, among other attributes. A segment number could be assigned to all or a portion of such an object in a file system. In other systems, data segments are handled with a segment number assigned elsewhere. For purposes of discussion, the unit of distribution is an entity, and an entity can be a file, a directory or a segment. That is, entities are units of data or metadata stored by a storage system. Entities are grouped into sets called authorities. Each authority has an authority owner, which is a storage node that has the exclusive right to update the entities in the authority. In other words, a storage node contains the authority, and that the authority, in turn, contains entities.

A segment is a logical container of data in accordance with some embodiments. A segment is an address space between medium address space and physical flash locations, i.e., the data segment number, are in this address space. Segments may also contain meta-data, which enable data redundancy to be restored (rewritten to different flash locations or devices) without the involvement of higher level software. In one embodiment, an internal format of a segment contains client data and medium mappings to determine the position of that data. Each data segment is protected, e.g., from memory and other failures, by breaking the segment into a number of data and parity shards, where applicable. The data and parity shards are distributed, i.e., striped, across non-volatile solid state storage **152** coupled to the host CPUs **156** (See FIGS. **2E** and **2G**) in accordance with an erasure coding scheme. Usage of the term segments refers to the container and its place in the address space of segments in some embodiments. Usage of the term stripe refers to the same set of shards as a segment and includes how the shards are distributed along with redundancy or parity information in accordance with some embodiments.

A series of address-space transformations takes place across an entire storage system. At the top are the directory entries (file names) which link to an inode. Inodes point into medium address space, where data is logically stored. Medium addresses may be mapped through a series of indirect mediums to spread the load of large files, or implement data services like deduplication or snapshots. Medium addresses may be mapped through a series of indirect mediums to spread the load of large files, or implement data services like deduplication or snapshots. Segment addresses are then translated into physical flash locations. Physical flash locations have an address range bounded by the amount of flash in the system in accordance with some embodiments. Medium addresses and segment addresses are logical containers, and in some embodiments use a 128 bit or larger identifier so as to be practically infinite, with a likelihood of reuse calculated as longer than the expected life of the system. Addresses from logical containers are allocated in a hierarchical fashion in some embodiments. Initially, each non-volatile solid state storage

unit **152** may be assigned a range of address space. Within this assigned range, the non-volatile solid state storage **152** is able to allocate addresses without synchronization with other non-volatile solid state storage **152**.

Data and metadata is stored by a set of underlying storage layouts that are optimized for varying workload patterns and storage devices. These layouts incorporate multiple redundancy schemes, compression formats and index algorithms. Some of these layouts store information about authorities and authority masters, while others store file metadata and file data. The redundancy schemes include error correction codes that tolerate corrupted bits within a single storage device (such as a NAND flash chip), erasure codes that tolerate the failure of multiple storage nodes, and replication schemes that tolerate data center or regional failures. In some embodiments, low density parity check (LDPC) code is used within a single storage unit. Reed-Solomon encoding is used within a storage cluster, and mirroring is used within a storage grid in some embodiments. Metadata may be stored using an ordered log structured index (such as a Log Structured Merge Tree), and large data may not be stored in a log structured layout.

In order to maintain consistency across multiple copies of an entity, the storage nodes agree implicitly on two things through calculations: (1) the authority that contains the entity, and (2) the storage node that contains the authority. The assignment of entities to authorities can be done by pseudo randomly assigning entities to authorities, by splitting entities into ranges based upon an externally produced key, or by placing a single entity into each authority. Examples of pseudorandom schemes are linear hashing and the Replication Under Scalable Hashing (RUSH) family of hashes, including Controlled Replication Under Scalable Hashing (CRUSH). In some embodiments, pseudo-random assignment is utilized only for assigning authorities to nodes because the set of nodes can change. The set of authorities cannot change so any subjective function may be applied in these embodiments. Some placement schemes automatically place authorities on storage nodes, while other placement schemes rely on an explicit mapping of authorities to storage nodes. In some embodiments, a pseudorandom scheme is utilized to map from each authority to a set of candidate authority owners. A pseudorandom data distribution function related to CRUSH may assign authorities to storage nodes and create a list of where the authorities are assigned. Each storage node has a copy of the pseudorandom data distribution function, and can arrive at the same calculation for distributing, and later finding or locating an authority. Each of the pseudorandom schemes requires the reachable set of storage nodes as input in some embodiments in order to conclude the same target nodes. Once an entity has been placed in an authority, the entity may be stored on physical devices so that no expected failure will lead to unexpected data loss. In some embodiments, rebalancing algorithms attempt to store the copies of all entities within an authority in the same layout and on the same set of machines.

Examples of expected failures include device failures, stolen machines, datacenter fires, and regional disasters, such as nuclear or geological events. Different failures lead to different levels of acceptable data loss. In some embodiments, a stolen storage node impacts neither the security nor the reliability of the system, while depending on system configuration, a regional event could lead to no loss of data, a few seconds or minutes of lost updates, or even complete data loss.

In the embodiments, the placement of data for storage redundancy is independent of the placement of authorities

for data consistency. In some embodiments, storage nodes that contain authorities do not contain any persistent storage. Instead, the storage nodes are connected to non-volatile solid state storage units that do not contain authorities. The communications interconnect between storage nodes and non-volatile solid state storage units consists of multiple communication technologies and has non-uniform performance and fault tolerance characteristics. In some embodiments, as mentioned above, non-volatile solid state storage units are connected to storage nodes via PCI express, storage nodes are connected together within a single chassis using Ethernet backplane, and chassis are connected together to form a storage cluster. Storage clusters are connected to clients using Ethernet or fiber channel in some embodiments. If multiple storage clusters are configured into a storage grid, the multiple storage clusters are connected using the Internet or other long-distance networking links, such as a “metro scale” link or private link that does not traverse the internet.

Authority owners have the exclusive right to modify entities, to migrate entities from one non-volatile solid state storage unit to another non-volatile solid state storage unit, and to add and remove copies of entities. This allows for maintaining the redundancy of the underlying data. When an authority owner fails, is going to be decommissioned, or is overloaded, the authority is transferred to a new storage node. Transient failures make it non-trivial to ensure that all non-faulty machines agree upon the new authority location. The ambiguity that arises due to transient failures can be achieved automatically by a consensus protocol such as Paxos, hot-warm failover schemes, via manual intervention by a remote system administrator, or by a local hardware administrator (such as by physically removing the failed machine from the cluster, or pressing a button on the failed machine). In some embodiments, a consensus protocol is used, and failover is automatic. If too many failures or replication events occur in too short a time period, the system goes into a self-preservation mode and halts replication and data movement activities until an administrator intervenes in accordance with some embodiments.

As authorities are transferred between storage nodes and authority owners update entities in their authorities, the system transfers messages between the storage nodes and non-volatile solid state storage units. With regard to persistent messages, messages that have different purposes are of different types. Depending on the type of the message, the system maintains different ordering and durability guarantees. As the persistent messages are being processed, the messages are temporarily stored in multiple durable and non-durable storage hardware technologies. In some embodiments, messages are stored in RAM, NVRAM and on NAND flash devices, and a variety of protocols are used in order to make efficient use of each storage medium. Latency-sensitive client requests may be persisted in replicated NVRAM, and then later NAND, while background rebalancing operations are persisted directly to NAND.

Persistent messages are persistently stored prior to being transmitted. This allows the system to continue to serve client requests despite failures and component replacement. Although many hardware components contain unique identifiers that are visible to system administrators, manufacturer, hardware supply chain and ongoing monitoring quality control infrastructure, applications running on top of the infrastructure address virtualize addresses. These virtualized addresses do not change over the lifetime of the storage system, regardless of component failures and replacements. This allows each component of the storage system to be

replaced over time without reconfiguration or disruptions of client request processing, i.e., the system supports non-disruptive upgrades.

In some embodiments, the virtualized addresses are stored with sufficient redundancy. A continuous monitoring system correlates hardware and software status and the hardware identifiers. This allows detection and prediction of failures due to faulty components and manufacturing details. The monitoring system also enables the proactive transfer of authorities and entities away from impacted devices before failure occurs by removing the component from the critical path in some embodiments.

FIG. 2C is a multiple level block diagram, showing contents of a storage node **150** and contents of a non-volatile solid state storage **152** of the storage node **150**. Data is communicated to and from the storage node **150** by a network interface controller (NIC) **202** in some embodiments. Each storage node **150** has a CPU **156**, and one or more non-volatile solid state storage **152**, as discussed above. Moving down one level in FIG. 2C, each non-volatile solid state storage **152** has a relatively fast non-volatile solid state memory, such as nonvolatile random access memory (NVRAM) **204**, and flash memory **206**. In some embodiments, NVRAM **204** may be a component that does not require program/erase cycles (DRAM, MRAM, PCM), and can be a memory that can support being written vastly more often than the memory is read from. Moving down another level in FIG. 2C, the NVRAM **204** is implemented in one embodiment as high speed volatile memory, such as dynamic random access memory (DRAM) **216**, backed up by energy reserve **218**. Energy reserve **218** provides sufficient electrical power to keep the DRAM **216** powered long enough for contents to be transferred to the flash memory **206** in the event of power failure. In some embodiments, energy reserve **218** is a capacitor, super-capacitor, battery, or other device, that supplies a suitable supply of energy sufficient to enable the transfer of the contents of DRAM **216** to a stable storage medium in the case of power loss. The flash memory **206** is implemented as multiple flash dies **222**, which may be referred to as packages of flash dies **222** or an array of flash dies **222**. It should be appreciated that the flash dies **222** could be packaged in any number of ways, with a single die per package, multiple dies per package (i.e. multichip packages), in hybrid packages, as bare dies on a printed circuit board or other substrate, as encapsulated dies, etc. In the embodiment shown, the non-volatile solid state storage **152** has a controller **212** or other processor, and an input output (I/O) port **210** coupled to the controller **212**. I/O port **210** is coupled to the CPU **156** and/or the network interface controller **202** of the flash storage node **150**. Flash input output (I/O) port **220** is coupled to the flash dies **222**, and a direct memory access unit (DMA) **214** is coupled to the controller **212**, the DRAM **216** and the flash dies **222**. In the embodiment shown, the I/O port **210**, controller **212**, DMA unit **214** and flash I/O port **220** are implemented on a programmable logic device (PLD) **208**, e.g., a field programmable gate array (FPGA). In this embodiment, each flash die **222** has pages, organized as sixteen kB (kilobyte) pages **224**, and a register **226** through which data can be written to or read from the flash die **222**. In further embodiments, other types of solid-state memory are used in place of, or in addition to flash memory illustrated within flash die **222**.

Storage clusters **161**, in various embodiments as disclosed herein, can be contrasted with storage arrays in general. The storage nodes **150** are part of a collection that creates the storage cluster **161**. Each storage node **150** owns a slice of

data and computing required to provide the data. Multiple storage nodes **150** cooperate to store and retrieve the data. Storage memory or storage devices, as used in storage arrays in general, are less involved with processing and manipulating the data. Storage memory or storage devices in a storage array receive commands to read, write, or erase data. The storage memory or storage devices in a storage array are not aware of a larger system in which they are embedded, or what the data means. Storage memory or storage devices in storage arrays can include various types of storage memory, such as RAM, solid state drives, hard disk drives, etc. The storage units **152** described herein have multiple interfaces active simultaneously and serving multiple purposes. In some embodiments, some of the functionality of a storage node **150** is shifted into a storage unit **152**, transforming the storage unit **152** into a combination of storage unit **152** and storage node **150**. Placing computing (relative to storage data) into the storage unit **152** places this computing closer to the data itself. The various system embodiments have a hierarchy of storage node layers with different capabilities. By contrast, in a storage array, a controller owns and knows everything about all of the data that the controller manages in a shelf or storage devices. In a storage cluster **161**, as described herein, multiple controllers in multiple storage units **152** and/or storage nodes **150** cooperate in various ways (e.g., for erasure coding, data sharding, metadata communication and redundancy, storage capacity expansion or contraction, data recovery, and so on).

FIG. 2D shows a storage server environment, which uses embodiments of the storage nodes **150** and storage units **152** of FIGS. 2A-C. In this version, each storage unit **152** has a processor such as controller **212** (see FIG. 2C), an FPGA (field programmable gate array), flash memory **206**, and NVRAM **204** (which is super-capacitor backed DRAM **216**, see FIGS. 2B and 2C) on a PCIe (peripheral component interconnect express) board in a chassis **138** (see FIG. 2A). The storage unit **152** may be implemented as a single board containing storage, and may be the largest tolerable failure domain inside the chassis. In some embodiments, up to two storage units **152** may fail and the device will continue with no data loss.

The physical storage is divided into named regions based on application usage in some embodiments. The NVRAM **204** is a contiguous block of reserved memory in the storage unit **152** DRAM **216**, and is backed by NAND flash. NVRAM **204** is logically divided into multiple memory regions written for two as spool (e.g., spool_region). Space within the NVRAM **204** spools is managed by each authority **168** independently. Each device provides an amount of storage space to each authority **168**. That authority **168** further manages lifetimes and allocations within that space. Examples of a spool include distributed transactions or notions. When the primary power to a storage unit **152** fails, onboard super-capacitors provide a short duration of power hold up. During this holdup interval, the contents of the NVRAM **204** are flushed to flash memory **206**. On the next power-on, the contents of the NVRAM **204** are recovered from the flash memory **206**.

As for the storage unit controller, the responsibility of the logical “controller” is distributed across each of the blades containing authorities **168**. This distribution of logical control is shown in FIG. 2D as a host controller **242**, mid-tier controller **244** and storage unit controller(s) **246**. Management of the control plane and the storage plane are treated independently, although parts may be physically co-located on the same blade. Each authority **168** effectively serves as an independent controller. Each authority **168** provides its

own data and metadata structures, its own background workers, and maintains its own lifecycle.

FIG. 2E is a blade **252** hardware block diagram, showing a control plane **254**, compute and storage planes **256**, **258**, and authorities **168** interacting with underlying physical resources, using embodiments of the storage nodes **150** and storage units **152** of FIGS. 2A-C in the storage server environment of FIG. 2D. The control plane **254** is partitioned into a number of authorities **168** which can use the compute resources in the compute plane **256** to run on any of the blades **252**. The storage plane **258** is partitioned into a set of devices, each of which provides access to flash **206** and NVRAM **204** resources.

In the compute and storage planes **256**, **258** of FIG. 2E, the authorities **168** interact with the underlying physical resources (i.e., devices). From the point of view of an authority **168**, its resources are striped over all of the physical devices. From the point of view of a device, it provides resources to all authorities **168**, irrespective of where the authorities happen to run. Each authority **168** has allocated or has been allocated one or more partitions **260** of storage memory in the storage units **152**, e.g. partitions **260** in flash memory **206** and NVRAM **204**. Each authority **168** uses those allocated partitions **260** that belong to it, for writing or reading user data. Authorities can be associated with differing amounts of physical storage of the system. For example, one authority **168** could have a larger number of partitions **260** or larger sized partitions **260** in one or more storage units **152** than one or more other authorities **168**.

FIG. 2F depicts elasticity software layers in blades **252** of a storage cluster **161**, in accordance with some embodiments. In the elasticity structure, elasticity software is symmetric, i.e., each blade’s compute module **270** runs the three identical layers of processes depicted in FIG. 2F. Storage managers **274** execute read and write requests from other blades **252** for data and metadata stored in local storage unit **152** NVRAM **204** and flash **206**. Authorities **168** fulfill client requests by issuing the necessary reads and writes to the blades **252** on whose storage units **152** the corresponding data or metadata resides. Endpoints **272** parse client connection requests received from switch fabric **146** supervisory software, relay the client connection requests to the authorities **168** responsible for fulfillment, and relay the authorities’ **168** responses to clients. The symmetric three-layer structure enables the storage system’s high degree of concurrency. Elasticity scales out efficiently and reliably in these embodiments. In addition, elasticity implements a unique scale-out technique that balances work evenly across all resources regardless of client access pattern, and maximizes concurrency by eliminating much of the need for inter-blade coordination that typically occurs with conventional distributed locking.

Still referring to FIG. 2F, authorities **168** running in the compute modules **270** of a blade **252** perform the internal operations required to fulfill client requests. One feature of elasticity is that authorities **168** are stateless, i.e., they cache active data and metadata in their own blades’ **168** DRAMs for fast access, but the authorities store every update in their NVRAM **204** partitions on three separate blades **252** until the update has been written to flash **206**. All the storage system writes to NVRAM **204** are in triplicate to partitions on three separate blades **252** in some embodiments. With triple-mirrored NVRAM **204** and persistent storage protected by parity and Reed-Solomon RAID checksums, the storage system can survive concurrent failure of two blades **252** with no loss of data, metadata, or access to either.

Because authorities **168** are stateless, they can migrate between blades **252**. Each authority **168** has a unique identifier. NVRAM **204** and flash **206** partitions are associated with authorities' **168** identifiers, not with the blades **252** on which they are running in some. Thus, when an authority **168** migrates, the authority **168** continues to manage the same storage partitions from its new location. When a new blade **252** is installed in an embodiment of the storage cluster **161**, the system automatically rebalances load by:

Partitioning the new blade's **252** storage for use by the system's authorities **168**,

Migrating selected authorities **168** to the new blade **252**,
Starting endpoints **272** on the new blade **252** and including them in the switch fabric's **146** client connection distribution algorithm.

From their new locations, migrated authorities **168** persist the contents of their NVRAM **204** partitions on flash **206**, process read and write requests from other authorities **168**, and fulfill the client requests that endpoints **272** direct to them. Similarly, if a blade **252** fails or is removed, the system redistributes its authorities **168** among the system's remaining blades **252**. The redistributed authorities **168** continue to perform their original functions from their new locations.

FIG. 2G depicts authorities **168** and storage resources in blades **252** of a storage cluster, in accordance with some embodiments. Each authority **168** is exclusively responsible for a partition of the flash **206** and NVRAM **204** on each blade **252**. The authority **168** manages the content and integrity of its partitions independently of other authorities **168**. Authorities **168** compress incoming data and preserve it temporarily in their NVRAM **204** partitions, and then consolidate, RAID-protect, and persist the data in segments of the storage in their flash **206** partitions. As the authorities **168** write data to flash **206**, storage managers **274** perform the necessary flash translation to optimize write performance and maximize media longevity. In the background, authorities **168** "garbage collect," or reclaim space occupied by data that clients have made obsolete by overwriting the data. It should be appreciated that since authorities' **168** partitions are disjoint, there is no need for distributed locking to execute client and writes or to perform background functions.

The embodiments described herein may utilize various software, communication and/or networking protocols. In addition, the configuration of the hardware and/or software may be adjusted to accommodate various protocols. For example, the embodiments may utilize Active Directory, which is a database based system that provides authentication, directory, policy, and other services in a WINDOWS™ environment. In these embodiments, LDAP (Lightweight Directory Access Protocol) is one example application protocol for querying and modifying items in directory service providers such as Active Directory. In some embodiments, a network lock manager (NLM) is utilized as a facility that works in cooperation with the Network File System (NFS) to provide a System V style of advisory file and record locking over a network. The Server Message Block (SMB) protocol, one version of which is also known as Common Internet File System (CIFS), may be integrated with the storage systems discussed herein. SMP operates as an application-layer network protocol typically used for providing shared access to files, printers, and serial ports and miscellaneous communications between nodes on a network. SMB also provides an authenticated inter-process communication mechanism. AMAZON™ S3 (Simple Storage Service) is a web service offered by Amazon Web Services, and the

systems described herein may interface with Amazon S3 through web services interfaces (REST (representational state transfer), SOAP (simple object access protocol), and BitTorrent). A RESTful API (application programming interface) breaks down a transaction to create a series of small modules. Each module addresses a particular underlying part of the transaction. The control or permissions provided with these embodiments, especially for object data, may include utilization of an access control list (ACL). The ACL is a list of permissions attached to an object and the ACL specifies which users or system processes are granted access to objects, as well as what operations are allowed on given objects. The systems may utilize Internet Protocol version 6 (IPv6), as well as IPv4, for the communications protocol that provides an identification and location system for computers on networks and routes traffic across the Internet. The routing of packets between networked systems may include Equal-cost multi-path routing (ECMP), which is a routing strategy where next-hop packet forwarding to a single destination can occur over multiple "best paths" which tie for top place in routing metric calculations. Multi-path routing can be used in conjunction with most routing protocols, because it is a per-hop decision limited to a single router. The software may support Multi-tenancy, which is an architecture in which a single instance of a software application serves multiple customers. Each customer may be referred to as a tenant. Tenants may be given the ability to customize some parts of the application, but may not customize the application's code, in some embodiments. The embodiments may maintain audit logs. An audit log is a document that records an event in a computing system. In addition to documenting what resources were accessed, audit log entries typically include destination and source addresses, a timestamp, and user login information for compliance with various regulations. The embodiments may support various key management policies, such as encryption key rotation. In addition, the system may support dynamic root passwords or some variation dynamically changing passwords.

FIG. 3A sets forth a diagram of a storage system **306** that is coupled for data communications with a cloud services provider **302** in accordance with some embodiments of the present disclosure. Although depicted in less detail, the storage system **306** depicted in FIG. 3A may be similar to the storage systems described above with reference to FIGS. 1A-1D and FIGS. 2A-2G. In some embodiments, the storage system **306** depicted in FIG. 3A may be embodied as a storage system that includes imbalanced active/active controllers, as a storage system that includes balanced active/active controllers, as a storage system that includes active/active controllers where less than all of each controller's resources are utilized such that each controller has reserve resources that may be used to support failover, as a storage system that includes fully active/active controllers, as a storage system that includes dataset-segregated controllers, as a storage system that includes dual-layer architectures with front-end controllers and back-end integrated storage controllers, as a storage system that includes scale-out clusters of dual-controller arrays, as well as combinations of such embodiments.

In the example depicted in FIG. 3A, the storage system **306** is coupled to the cloud services provider **302** via a data communications link **304**. The data communications link **304** may be embodied as a dedicated data communications link, as a data communications pathway that is provided through the use of one or data communications networks such as a wide area network ("WAN") or local area network

25

(‘LAN’), or as some other mechanism capable of transporting digital information between the storage system 306 and the cloud services provider 302. Such a data communications link 304 may be fully wired, fully wireless, or some aggregation of wired and wireless data communications pathways. In such an example, digital information may be exchanged between the storage system 306 and the cloud services provider 302 via the data communications link 304 using one or more data communications protocols. For example, digital information may be exchanged between the storage system 306 and the cloud services provider 302 via the data communications link 304 using the handheld device transfer protocol (‘HDTP’), hypertext transfer protocol (‘HTTP’), internet protocol (‘IP’), real-time transfer protocol (‘RTP’), transmission control protocol (‘TCP’), user datagram protocol (‘UDP’), wireless application protocol (‘WAP’), or other protocol.

The cloud services provider 302 depicted in FIG. 3A may be embodied, for example, as a system and computing environment that provides services to users of the cloud services provider 302 through the sharing of computing resources via the data communications link 304. The cloud services provider 302 may provide on-demand access to a shared pool of configurable computing resources such as computer networks, servers, storage, applications and services, and so on. The shared pool of configurable resources may be rapidly provisioned and released to a user of the cloud services provider 302 with minimal management effort. Generally, the user of the cloud services provider 302 is unaware of the exact computing resources utilized by the cloud services provider 302 to provide the services. Although in many cases such a cloud services provider 302 may be accessible via the Internet, readers of skill in the art will recognize that any system that abstracts the use of shared resources to provide services to a user through any data communications link may be considered a cloud services provider 302.

In the example depicted in FIG. 3A, the cloud services provider 302 may be configured to provide a variety of services to the storage system 306 and users of the storage system 306 through the implementation of various service models. For example, the cloud services provider 302 may be configured to provide services to the storage system 306 and users of the storage system 306 through the implementation of an infrastructure as a service (‘IaaS’) service model where the cloud services provider 302 offers computing infrastructure such as virtual machines and other resources as a service to subscribers. In addition, the cloud services provider 302 may be configured to provide services to the storage system 306 and users of the storage system 306 through the implementation of a platform as a service (‘PaaS’) service model where the cloud services provider 302 offers a development environment to application developers. Such a development environment may include, for example, an operating system, programming-language execution environment, database, web server, or other components that may be utilized by application developers to develop and run software solutions on a cloud platform. Furthermore, the cloud services provider 302 may be configured to provide services to the storage system 306 and users of the storage system 306 through the implementation of a software as a service (‘SaaS’) service model where the cloud services provider 302 offers application software, databases, as well as the platforms that are used to run the applications to the storage system 306 and users of the storage system 306, providing the storage system 306 and users of the storage system 306 with on-demand software

26

and eliminating the need to install and run the application on local computers, which may simplify maintenance and support of the application. The cloud services provider 302 may be further configured to provide services to the storage system 306 and users of the storage system 306 through the implementation of an authentication as a service (‘AaaS’) service model where the cloud services provider 302 offers authentication services that can be used to secure access to applications, data sources, or other resources. The cloud services provider 302 may also be configured to provide services to the storage system 306 and users of the storage system 306 through the implementation of a storage as a service model where the cloud services provider 302 offers access to its storage infrastructure for use by the storage system 306 and users of the storage system 306. Readers will appreciate that the cloud services provider 302 may be configured to provide additional services to the storage system 306 and users of the storage system 306 through the implementation of additional service models, as the service models described above are included only for explanatory purposes and in no way represent a limitation of the services that may be offered by the cloud services provider 302 or a limitation as to the service models that may be implemented by the cloud services provider 302.

In the example depicted in FIG. 3A, the cloud services provider 302 may be embodied, for example, as a private cloud, as a public cloud, or as a combination of a private cloud and public cloud. In an embodiment in which the cloud services provider 302 is embodied as a private cloud, the cloud services provider 302 may be dedicated to providing services to a single organization rather than providing services to multiple organizations. In an embodiment where the cloud services provider 302 is embodied as a public cloud, the cloud services provider 302 may provide services to multiple organizations. Public cloud and private cloud deployment models may differ and may come with various advantages and disadvantages. For example, because a public cloud deployment involves the sharing of a computing infrastructure across different organization, such a deployment may not be ideal for organizations with security concerns, mission-critical workloads, uptime requirements demands, and so on. While a private cloud deployment can address some of these issues, a private cloud deployment may require on-premises staff to manage the private cloud. In still alternative embodiments, the cloud services provider 302 may be embodied as a mix of a private and public cloud services with a hybrid cloud deployment.

Although not explicitly depicted in FIG. 3A, readers will appreciate that additional hardware components and additional software components may be necessary to facilitate the delivery of cloud services to the storage system 306 and users of the storage system 306. For example, the storage system 306 may be coupled to (or even include) a cloud storage gateway. Such a cloud storage gateway may be embodied, for example, as hardware-based or software-based appliance that is located on premise with the storage system 306. Such a cloud storage gateway may operate as a bridge between local applications that are executing on the storage array 306 and remote, cloud-based storage that is utilized by the storage array 306. Through the use of a cloud storage gateway, organizations may move primary iSCSI or NAS to the cloud services provider 302, thereby enabling the organization to save space on their on-premises storage systems. Such a cloud storage gateway may be configured to emulate a disk array, a block-based device, a file server, or other storage system that can translate the SCSI commands, file server commands, or other appropriate command into

REST-space protocols that facilitate communications with the cloud services provider 302.

In order to enable the storage system 306 and users of the storage system 306 to make use of the services provided by the cloud services provider 302, a cloud migration process may take place during which data, applications, or other elements from an organization's local systems (or even from another cloud environment) are moved to the cloud services provider 302. In order to successfully migrate data, applications, or other elements to the cloud services provider's 302 environment, middleware such as a cloud migration tool may be utilized to bridge gaps between the cloud services provider's 302 environment and an organization's environment. Such cloud migration tools may also be configured to address potentially high network costs and long transfer times associated with migrating large volumes of data to the cloud services provider 302, as well as addressing security concerns associated with sensitive data to the cloud services provider 302 over data communications networks. In order to further enable the storage system 306 and users of the storage system 306 to make use of the services provided by the cloud services provider 302, a cloud orchestrator may also be used to arrange and coordinate automated tasks in pursuit of creating a consolidated process or workflow. Such a cloud orchestrator may perform tasks such as configuring various components, whether those components are cloud components or on-premises components, as well as managing the interconnections between such components. The cloud orchestrator can simplify the inter-component communication and connections to ensure that links are correctly configured and maintained.

In the example depicted in FIG. 3A, and as described briefly above, the cloud services provider 302 may be configured to provide services to the storage system 306 and users of the storage system 306 through the usage of a SaaS service model where the cloud services provider 302 offers application software, databases, as well as the platforms that are used to run the applications to the storage system 306 and users of the storage system 306, providing the storage system 306 and users of the storage system 306 with on-demand software and eliminating the need to install and run the application on local computers, which may simplify maintenance and support of the application. Such applications may take many forms in accordance with various embodiments of the present disclosure. For example, the cloud services provider 302 may be configured to provide access to data analytics applications to the storage system 306 and users of the storage system 306. Such data analytics applications may be configured, for example, to receive telemetry data phoned home by the storage system 306. Such telemetry data may describe various operating characteristics of the storage system 306 and may be analyzed, for example, to determine the health of the storage system 306, to identify workloads that are executing on the storage system 306, to predict when the storage system 306 will run out of various resources, to recommend configuration changes, hardware or software upgrades, workflow migrations, or other actions that may improve the operation of the storage system 306.

The cloud services provider 302 may also be configured to provide access to virtualized computing environments to the storage system 306 and users of the storage system 306. Such virtualized computing environments may be embodied, for example, as a virtual machine or other virtualized computer hardware platforms, virtual storage devices, virtualized computer network resources, and so on. Examples of such virtualized environments can include virtual

machines that are created to emulate an actual computer, virtualized desktop environments that separate a logical desktop from a physical machine, virtualized file systems that allow uniform access to different types of concrete file systems, and many others.

For further explanation, FIG. 3B sets forth a diagram of a storage system 306 in accordance with some embodiments of the present disclosure. Although depicted in less detail, the storage system 306 depicted in FIG. 3B may be similar to the storage systems described above with reference to FIGS. 1A-1D and FIGS. 2A-2G as the storage system may include many of the components described above.

The storage system 306 depicted in FIG. 3B may include storage resources 308, which may be embodied in many forms. For example, in some embodiments the storage resources 308 can include nano-RAM or another form of nonvolatile random access memory that utilizes carbon nanotubes deposited on a substrate. In some embodiments, the storage resources 308 may include 3D crosspoint non-volatile memory in which bit storage is based on a change of bulk resistance, in conjunction with a stackable cross-gridded data access array. In some embodiments, the storage resources 308 may include flash memory, including single-level cell ('SLC') NAND flash, multi-level cell ('MLC') NAND flash, triple-level cell ('TLC') NAND flash, quad-level cell ('QLC') NAND flash, and others. In some embodiments, the storage resources 308 may include non-volatile magnetoresistive random-access memory ('MRAM'), including spin transfer torque ('STT') MRAM, in which data is stored through the use of magnetic storage elements. In some embodiments, the example storage resources 308 may include non-volatile phase-change memory ('PCM') that may have the ability to hold multiple bits in a single cell as cells can achieve a number of distinct intermediary states. In some embodiments, the storage resources 308 may include quantum memory that allows for the storage and retrieval of photonic quantum information. In some embodiments, the example storage resources 308 may include resistive random-access memory ('ReRAM') in which data is stored by changing the resistance across a dielectric solid-state material. In some embodiments, the storage resources 308 may include storage class memory ('SCM') in which solid-state nonvolatile memory may be manufactured at a high density using some combination of sub-lithographic patterning techniques, multiple bits per cell, multiple layers of devices, and so on. Readers will appreciate that other forms of computer memories and storage devices may be utilized by the storage systems described above, including DRAM, SRAM, EEPROM, universal memory, and many others. The storage resources 308 depicted in FIG. 3A may be embodied in a variety of form factors, including but not limited to, dual in-line memory modules ('DIMMs'), non-volatile dual in-line memory modules ('NVDIMMs'), M.2, U.2, and others.

The example storage system 306 depicted in FIG. 3B may implement a variety of storage architectures. For example, storage systems in accordance with some embodiments of the present disclosure may utilize block storage where data is stored in blocks, and each block essentially acts as an individual hard drive. Storage systems in accordance with some embodiments of the present disclosure may utilize object storage, where data is managed as objects. Each object may include the data itself, a variable amount of metadata, and a globally unique identifier, where object storage can be implemented at multiple levels (e.g., device level, system level, interface level). Storage systems in accordance with some embodiments of the present disclo-

sure utilize file storage in which data is stored in a hierarchical structure. Such data may be saved in files and folders, and presented to both the system storing it and the system retrieving it in the same format.

The example storage system 306 depicted in FIG. 3B may be embodied as a storage system in which additional storage resources can be added through the use of a scale-up model, additional storage resources can be added through the use of a scale-out model, or through some combination thereof. In a scale-up model, additional storage may be added by adding additional storage devices. In a scale-out model, however, additional storage nodes may be added to a cluster of storage nodes, where such storage nodes can include additional processing resources, additional networking resources, and so on.

The storage system 306 depicted in FIG. 3B also includes communications resources 310 that may be useful in facilitating data communications between components within the storage system 306, as well as data communications between the storage system 306 and computing devices that are outside of the storage system 306. The communications resources 310 may be configured to utilize a variety of different protocols and data communication fabrics to facilitate data communications between components within the storage systems as well as computing devices that are outside of the storage system. For example, the communications resources 310 can include fibre channel ('FC') technologies such as FC fabrics and FC protocols that can transport SCSI commands over FC networks. The communications resources 310 can also include FC over ethernet ('FCoE') technologies through which FC frames are encapsulated and transmitted over Ethernet networks. The communications resources 310 can also include InfiniBand ('IB') technologies in which a switched fabric topology is utilized to facilitate transmissions between channel adapters. The communications resources 310 can also include NVM Express ('NVMe') technologies and NVMe over fabrics ('NVMeoF') technologies through which non-volatile storage media attached via a PCI express ('PCIe') bus may be accessed. The communications resources 310 can also include mechanisms for accessing storage resources 308 within the storage system 306 utilizing serial attached SCSI ('SAS'), serial ATA ('SATA') bus interfaces for connecting storage resources 308 within the storage system 306 to host bus adapters within the storage system 306, internet small computer systems interface ('iSCSI') technologies to provide block-level access to storage resources 308 within the storage system 306, and other communications resources that that may be useful in facilitating data communications between components within the storage system 306, as well as data communications between the storage system 306 and computing devices that are outside of the storage system 306.

The storage system 306 depicted in FIG. 3B also includes processing resources 312 that may be useful in useful in executing computer program instructions and performing other computational tasks within the storage system 306. The processing resources 312 may include one or more application-specific integrated circuits ('ASICs') that are customized for some particular purpose as well as one or more central processing units ('CPUs'). The processing resources 312 may also include one or more digital signal processors ('DSPs'), one or more field-programmable gate arrays ('FPGAs'), one or more systems on a chip ('SoCs'), or other form of processing resources 312. The storage system 306 may utilize the storage resources 312 to perform

a variety of tasks including, but not limited to, supporting the execution of software resources 314 that will be described in greater detail below.

The storage system 306 depicted in FIG. 3B also includes software resources 314 that, when executed by processing resources 312 within the storage system 306, may perform various tasks. The software resources 314 may include, for example, one or more modules of computer program instructions that when executed by processing resources 312 within the storage system 306 are useful in carrying out various data protection techniques to preserve the integrity of data that is stored within the storage systems. Readers will appreciate that such data protection techniques may be carried out, for example, by system software executing on computer hardware within the storage system, by a cloud services provider, or in other ways. Such data protection techniques can include, for example, data archiving techniques that cause data that is no longer actively used to be moved to a separate storage device or separate storage system for long-term retention, data backup techniques through which data stored in the storage system may be copied and stored in a distinct location to avoid data loss in the event of equipment failure or some other form of catastrophe with the storage system, data replication techniques through which data stored in the storage system is replicated to another storage system such that the data may be accessible via multiple storage systems, data snapshotting techniques through which the state of data within the storage system is captured at various points in time, data and database cloning techniques through which duplicate copies of data and databases may be created, and other data protection techniques. Through the use of such data protection techniques, business continuity and disaster recovery objectives may be met as a failure of the storage system may not result in the loss of data stored in the storage system.

The software resources 314 may also include software that is useful in implementing software-defined storage ('SDS'). In such an example, the software resources 314 may include one or more modules of computer program instructions that, when executed, are useful in policy-based provisioning and management of data storage that is independent of the underlying hardware. Such software resources 314 may be useful in implementing storage virtualization to separate the storage hardware from the software that manages the storage hardware.

The software resources 314 may also include software that is useful in facilitating and optimizing I/O operations that are directed to the storage resources 308 in the storage system 306. For example, the software resources 314 may include software modules that perform carry out various data reduction techniques such as, for example, data compression, data deduplication, and others. The software resources 314 may include software modules that intelligently group together I/O operations to facilitate better usage of the underlying storage resource 308, software modules that perform data migration operations to migrate from within a storage system, as well as software modules that perform other functions. Such software resources 314 may be embodied as one or more software containers or in many other ways.

Readers will appreciate that the various components depicted in FIG. 3B may be grouped into one or more optimized computing packages as converged infrastructures. Such converged infrastructures may include pools of computers, storage and networking resources that can be shared by multiple applications and managed in a collective manner using policy-driven processes. Such converged infrastruc-

tures may minimize compatibility issues between various components within the storage system **306** while also reducing various costs associated with the establishment and operation of the storage system **306**. Such converged infrastructures may be implemented with a converged infrastructure reference architecture, with standalone appliances, with a software driven hyper-converged approach, or in other ways.

Readers will appreciate that the storage system **306** depicted in FIG. 3B may be useful for supporting various types of software applications. For example, the storage system **306** may be useful in supporting artificial intelligence applications, database applications, DevOps projects, electronic design automation tools, event-driven software applications, high performance computing applications, simulation applications, high-speed data capture and analysis applications, machine learning applications, media production applications, media serving applications, picture archiving and communication systems ('PACS') applications, software development applications, and many other types of applications by providing storage resources to such applications.

FIG. 4 illustrates an example system **400** for data storage, in accordance with some implementations. In one embodiment, system **400** includes storage controllers **401A**, **401B** (also referred to herein as "storage system controllers"). In one embodiment, storage controllers **401A**, **401B** are operatively coupled to storage devices **403A-C** via one or more networks **402A**, **402B**. In one embodiment, storage controllers **401A**, **401B** provide storage services, such as a small computer system interface (SCSI) block storage array, a file server, an object server, a database or data analytics service, etc. The storage controllers **401A**, **401B** may provide services through some number of network interfaces to host computers outside of the storage system **400**. Storage controllers **401A**, **401B** may provide integrated services or an application entirely within the storage system **400**, forming a converged storage and compute system. The storage controllers **401A**, **401B** may utilize the fast write memory within or across storage devices **403A-C** to journal in progress operations to ensure the operations are not lost on a power failure, storage controller removal, storage controller or storage system shutdown, or some fault of one or more software or hardware components within the storage system **400**.

Storage devices **403A-C** may include solid-state drive (SSD) storage portions (e.g., **405A**), NVRAM portions (e.g., **404A**), an energy source (e.g., **406A**), and a processing device of a device controller. In one embodiment, the SSD portion includes a direct-mapped SSD, as described herein. In one embodiment, an NVRAM portion is an addressable memory range, in which data is persistent across power cycles. NVRAM portions may be volatile (e.g., operatively coupled to an energy source) or nonvolatile. In one embodiment, an NVRAM portion may include a dynamic random-access memory (DRAM) device and an energy source, a magnetoresistive random-access memory (MRAM) device, or a three-dimensional cross-point (3D XPoint) memory device. The NVRAM portions distributed across storage devices may form a redundant array of independent disks (RAID). In one embodiment, energy source **406A** may be utilized to provide power to volatile NVRAM modules (e.g., DRAM). For nonvolatile NVRAM portions, energy source **406A** may not be utilized to maintain NVRAM operations. In one embodiment the NVRAM portion may be any

volatile storage may include any of the non-volatile NVRAM configurations described herein. In one embodiment, such fast-write configurations do not utilize a stored energy source.

In one embodiment, storage controllers **401A**, **401B** operate as PCI masters to PCI buses. In another embodiment, network interfaces may be based on other communications standards (e.g., HyperTransport, InfiBand, etc.). Other storage system embodiments may operate storage controllers **401A**, **401B** as multi-masters for multiple PCI buses. Alternatively, a PCI/NVMe/NVMf switching infrastructure or fabric may connect multiple storage controllers. Some storage system embodiments may allow storage devices to communicate with each other directly rather than communicating only with storage controllers. In one embodiment, a storage device controller may be operable under direction from a storage controller to synthesize and transfer data to be stored into Flash memory devices from data that has been stored in RAM. For example, a recalculated version of RAM content may be transferred after a storage controller has determined that an operation has fully committed across the storage system, or when fast-write memory on the device has reached a certain used capacity, or after a certain amount of time, to ensure improve safety of the data or to release addressable fast-write capacity for reuse. This mechanism may be used, for example, to avoid a second transfer over a bus from the storage controllers **401A**, **401B**. In one embodiment, a recalculation may include compressing data, attaching indexing or other metadata, combining multiple data segments together, performing erasure code calculations, etc.

In one embodiment, under direction from a storage controller **401A**, **401B**, a storage device controller may be operable to calculate and transfer data to other storage devices from data stored in RAM without involvement of the storage controllers **401A**, **401B**. This operation may be used to mirror data stored in one controller to another controller, or it could be used to offload compression, data aggregation, and/or erasure coding calculations and transfers to storage devices to reduce load on storage controllers or the storage controller interface to the PCI bus.

A storage device controller may include mechanisms for implementing high availability primitives for use by other parts of a storage system external to the storage devices **403A-C**. For example, reservation or exclusion primitives may be provided so that, in a storage system with two storage controllers providing a highly available storage service, one storage controller may prevent the other storage controller from accessing or continuing to access the storage device. This could be used, for example, in cases where one controller detects that the other controller is not functioning properly or where the interconnect between the two storage controllers may itself not be functioning properly.

In one embodiment, a storage system for use with Dual PCI direct mapped storage devices with separately addressable fast write storage includes systems that manage erase blocks or groups of erase blocks as allocation units for storing data on behalf of the storage service running on the storage controllers, or for storing metadata (e.g., indexes, logs, etc.) associated with the storage service, or for proper management of the storage system itself. As used herein, "separately addressable" may include "separately or predictively addressable." Flash pages, which may be a few kilobytes in size, may be written as data arrives or as the storage system is to persist data for long intervals of time (e.g., above a defined threshold of time). To commit data more quickly, or to reduce the number of writes to the Flash

memory devices, the storage controllers may first write data into the separately addressable fast write storage on one more storage devices.

In one embodiment, the storage controllers **401A**, **401B** may initiate the use of erase blocks within and across storage devices in accordance with an age and expected remaining lifespan of the storage devices, or based on other statistics. The storage controllers **401A**, **401B** may initiate garbage collection and data migration data between storage devices in accordance with pages that are no longer needed as well as to manage Flash page and erase block lifespans and to manage overall system performance.

In one embodiment, the storage system **400** may utilize mirroring and/or erasure coding schemes as part of storing data into addressable fast write storage and/or as part of writing data into allocation units associated with erase blocks. Erasure codes may be used across storage devices, as well as within erase blocks or allocation units, or within and across Flash memory devices on a single storage device, to provide redundancy against single or multiple storage device failures or to protect against internal corruptions of Flash memory pages resulting from Flash memory operations or from degradation of Flash memory cells. Mirroring and erasure coding at various levels may be used to recover from multiple types of failures that occur separately or in combination.

In one embodiment, storage controllers **401A**, **401B** are to determine that data is to be stored in the first direct-mapped SSD storage portion of a first embedded storage device of the plurality of embedded storage devices and buffer the data in the second NVRAM portion of a second embedded storage device of the plurality of embedded storage devices. The first embedded storage device and the second embedded storage device may be the same embedded storage device. In one embodiment, to buffer the data in the second NVRAM portion of the second embedded storage device, the storage system controllers may store the data to the second NVRAM portion according to a remote direct memory access (RDMA) protocol. The storage system controllers may further be configured to map memory addresses of the second NVRAM portion of the embedded storage device to logic on the plurality of storage system controllers. In one example, the storage devices are connected through PCI or some another memory “mappable” bus type. In this example, the storage devices may be memory mapped to virtual memory on one or more of the storage controllers so that load and store instructions can be utilized instead of via a driver and a command set to program the transfer of data from storage controller memory to the storage device RAM.

In one embodiment, storage controllers **401A**, **401B** are to determine that an operation is to be performed on data and journal the data in the second fast-write portion of a first embedded storage device of the plurality of embedded storage devices. The storage controllers may journal all or a portion of the data. After the journal, storage controllers **401A**, **401B** are to determine that the data is to be stored in the first SSD storage portion of a second embedded storage device of the plurality of embedded storage devices and store the data in the first SSD storage portion of a second embedded storage device.

In one embodiment, storage system controllers **401A**, **401B** may detect a power failure to the plurality of embedded storage devices. If the power failure is detected, the storage system controllers **401A**, **401B** may copy the data from the second NVRAM portion of the second embedded storage device to a third direct-mapped (SSD) storage portion of a third embedded storage device. After resumption

from the power failure, or upon a system restart for any other reason, storage system controllers may read the data from the second NVRAM portion of the second embedded storage device, determine a recovery action based on the data, and perform the recovery action. In one embodiment, the third direct-mapped SSD storage portion is a subset of the second direct-mapped SSD storage portion. In another embodiment, the third direct-mapped SSD storage portion is separate from the first direct-mapped SSD storage portion.

FIG. 5 is a block diagram illustrating multiple NVRAM buffers connected via a switch, in accordance with some implementations. In one implementation, system **500** includes a storage array controller **510**. It may be noted that storage system controller **510** may include the same, more, or fewer elements configured in the same or different manner in other implementations. In another embodiment, more than one storage controller **510** may be included in system **500**. It may be noted that elements of other figures may be included below to help illustrate features of storage system controller **510**.

In implementations, storage system controller **510** is communicatively coupled, such as via a midplane (not shown), to one or more storage drives **171** and to one or more NVRAM devices **182** of the storage drives **171** that are included as part of a storage array **102**. The storage system controller **510** may be coupled to the midplane via one or more data communications links and the midplane may be coupled to the storage drives **171** and the NVRAM devices **182** via one or more data communications links. The data communications links described above are collectively illustrated by data communications links **508** and may include a Peripheral Component Interconnect Express (PCIe) bus, for example.

In implementations, storage system controller **510** may include an internal and/or an external switch coupled to the NVRAM **182A**, **182B** of storage drives **171A**, **171B**. The switch may be a computer hardware device that can create multiple endpoints out of a single endpoint, thereby enabling multiple devices to share a single endpoint. The switch may, for example, be a PCIe switch that is coupled to a PCIe bus (e.g., data communications link **508**) and presents multiple PCIe connection points to the midplane.

In one implementation, data communications links **508** enable NVRAM **182A** and NVRAM **182B** to communicate (e.g., transfer data) to each other without directly communicating with controller **510**. For example, Controller **510** may send data to NVRAM **182A** to be written. NVRAM **182A** may in turn send the data to NVRAM **182B** to be written. NVRAM **182B** may send an acknowledgement (an indication) back to NVRAM **182A** that the data was successfully written. NVRAM **182A** may then send an acknowledgement back to controller **510** that the data was written to both NVRAM **182A** and **182B**.

Controller **510** may initiate the receiving, by a processing device of first storage device (storage drive **171A**), from a second storage device (e.g., storage drive **171B**), first data to be stored in a first non-volatile random-access memory (NVRAM) portion of the first storage device. Controller **510** may further initiate the storing, by the processing device, the first data (e.g., a portion or all of the first data) in the first NVRAM portion of the first storage device and the sending, by the processing device, second data to a second NVRAM portion of a second storage device directly via a communication network. In another embodiment, instructions to store the first data may be received, where the instructions may include the first data (or a pointer to the first data) and/or a transformation that is to be applied to the first data before

storage. For example, the instructions may indicate that erasure codes are to be generated and stored based on the first data. In one embodiment, the communication network is a full-duplex switched network, a mesh network, a cross-connect, or direct point-to-point interconnection. In one embodiment, the instructions may identify multiple storage devices and the first storage device sends the first data (e.g., including a portion or transformation of the first data) to the multiple storage devices (e.g., following an erasure coding scheme defined by the system controller).

In one embodiment, the second data is a copy of the first data. In another embodiment, the first data is a first portion of an erasure code corresponding to third data and the second data is a second portion of the erasure code corresponding to the third data.

Controller 510 may further be configured to send, in response to storing the first data in the first NVRAM portion of the first storage device, an indication that the first data was stored in the first NVRAM portion of the first storage device directly to a storage controller associated with the second storage device. Controller 510 may further be configured to receive third data to be stored in the first NVRAM portion of the embedded storage device, calculate an erasure code corresponding to the third data, store a first portion of the erasure code in the first NVRAM portion of the first embedded storage device, and send a second portion of the erasure code to the second NVRAM portion of a second embedded storage device of the plurality of embedded storage devices directly via the full-duplex switched network. In one embodiment, plurality of NVRAM portions of the plurality of embedded storage devices form an erasure coded set. Advantageously, by enabling NVRAM 182A and NVRAM 182B to directly communicate with each other, and thus utilize bandwidth between the two, available bandwidth to and from the controller may be increased for other tasks.

FIG. 6A is a flow diagram illustrating distributed integrated high-speed solid-state NVRAM operations, in accordance with some implementations. In one implementation, method 600A may be performed by processing logic that includes hardware (e.g., circuitry, dedicated logic, programmable logic, microcode), software (e.g., instructions run on a processing device to perform hardware simulation), or a combination thereof. In one implementation, some or all the operations of method 600A may be performed by instructions 113 as described herein.

At block 602, processing logic determines, by a processing device of a storage system controller operatively coupled via a network to a plurality of storage devices, that data is to be stored in a first storage portion of a first storage device of the plurality of storage devices. At block 604, processing logic buffers the data in a second non-volatile random-access memory (NVRAM) portion of a second storage device of the plurality of storage devices. In one embodiment, the first storage portion and the second NVRAM portion are separately addressable.

FIG. 6B is a flow diagram illustrating direct NVRAM communication operations, in accordance with some implementations. In one implementation, method 600B may be performed by processing logic that includes hardware (e.g., circuitry, dedicated logic, programmable logic, microcode), software (e.g., instructions run on a processing device to perform hardware simulation), or a combination thereof. In one implementation, some or all the operations of method 600B may be performed by instructions 113 as described herein.

At block 606, processing logic receives, by a processing device of a first storage device, from a second storage

device, first data to be stored in a first non-volatile random-access memory (NVRAM) portion of the first storage device. At block 608, processing logic stores, by the processing device, the first data in the first NVRAM portion of the first storage device. At block 610, processing logic sends, by the processing device, second data to a second NVRAM portion of a second storage device directly via a communication network.

What is claimed is:

1. A storage system comprising:

a plurality of embedded storage devices, wherein each embedded storage device of the plurality of embedded storage devices comprises;

a first direct-mapped solid state drive (SSD) storage portion, wherein the first direct-mapped SSD storage portion has erase blocks mapped as directly addressable storage of the SSD; and

a second non-volatile random-access memory (NVRAM) portion comprising a random access memory (RAM) device and a processing device, wherein the first direct-mapped SSD portion and the second NVRAM portion are separately addressable, and wherein the second NVRAM portion is smaller capacity than the first direct-mapped SSD portion; and

a plurality of storage system controllers, operatively coupled to the plurality embedded storage devices via a bus, the plurality of storage system controllers to:

determine that data is to be stored in the first direct-mapped SSD storage portion of a first embedded storage device of the plurality of embedded storage devices; and

buffer the data in the second NVRAM portion of a second embedded storage device of the plurality of embedded storage devices.

2. The storage system of claim 1, wherein a plurality of second NVRAM portions of the plurality of embedded storage devices form a redundant array of independent disks (RAID).

3. The storage system of claim 1, wherein after resumption from a power failure the plurality of storage system controllers are further to:

read the data from the second NVRAM portion of the second embedded storage device;

determine a recovery action based on the data; and perform the recovery action.

4. The storage system of claim 3, wherein to perform the recovery action, the plurality of storage system controllers are to copy the data from the second NVRAM portion of the second embedded storage device to a third direct-mapped SSD storage portion of the second embedded storage device, wherein the third direct-mapped SSD storage portion is a subset of the first direct-mapped SSD storage portion.

5. The storage system of claim 3, wherein to perform the recovery action, the plurality of storage system controllers are to copy the data from the second NVRAM portion of the second embedded storage device to a third direct-mapped SSD storage portion of the second embedded storage device, wherein the third direct-mapped SSD storage portion is separate from the first direct-mapped SSD storage portion.

6. The storage system of claim 1, wherein the RAM device is a dynamic random-access memory (DRAM) device.

7. The storage system of claim 1, wherein the first embedded storage device and the second embedded storage device are a same embedded storage device.

37

8. The storage system of claim 1, wherein to buffer the data in the second NVRAM portion of the second embedded storage device, the plurality of storage system controllers are further to store the data to the second NVRAM portion according to a remote direct memory access (RDMA) protocol.

9. The storage system of claim 1, wherein the plurality of storage system controllers are further to map memory addresses of the second NVRAM portion of the embedded storage device to logic on the plurality of storage system controllers.

10. A storage system comprising:

a plurality of embedded storage devices, wherein each embedded storage device of the plurality of embedded storage devices comprises:

a first solid state drive (SSD) storage portion, wherein the first SSD storage portion has erase blocks mapped as directly addressable storage of the SSD; and

a second non-volatile fast-write portion, wherein the first SSD portion and the second fast-write portion are separately addressable; and

a storage system controller, operatively coupled to the plurality of embedded storage devices, the storage system controller to:

determine that an operation is to be performed on data; journal the data in the second fast-write portion of a first embedded storage device of the plurality of embedded storage devices;

after the journal, determine that the data is to be stored in the first SSD storage portion of a second embedded storage device of the plurality of embedded storage devices; and

store the data in the first SSD storage portion of a second embedded storage device.

11. The storage system of claim 10, wherein after resumption from a failure the storage system controller is to:

read the data from the second fast-write portion of the first embedded storage device;

determine a recovery action based on the data; and perform the recovery action.

12. The storage system of claim 11, wherein to perform the recovery action, the storage system controller is to copy the data from the second fast-write portion of the first embedded storage device to a third direct-mapped SSD storage portion of the second embedded storage device, wherein the third direct-mapped SSD storage portion is a subset of the first direct-mapped SSD storage portion.

13. The storage system of claim 11, wherein to perform the recovery action, the storage system controller is to copy the data from the second fast-write portion of the second embedded storage device to a third direct-mapped SSD storage portion of the second embedded storage device, wherein the third direct-mapped SSD storage portion is separate from the first direct-mapped SSD storage portion.

38

14. The storage system of claim 10, wherein the first embedded storage device and the second embedded storage device are a same embedded storage device.

15. The storage system of claim 10, wherein the fast-write portion comprises a processing device and at least one of: magnetoresistive random-access memory (MRAM), three-dimensional crosspoint memory (Xpoint), low-capacity, high duration single-level-cell (SLC) flash memory, or random-access memory (RAM) operatively coupled to an energy storage device.

16. The storage system of claim 10, wherein to store the data in the second fast-write portion of the first embedded storage device, the storage system controller is further to store the data to the first fast-write portion according to a remote direct memory access (RDMA) protocol.

17. The storage system of claim 10, wherein the storage system controller is further to snap memory addresses of the second fast-write portion of the first embedded storage device to logic on the storage system controller.

18. A method, comprising:

determining, by a processing device of a storage system controller operatively coupled via a network to a plurality of storage devices, that data is to be stored its a first storage portion of a first storage device of the plurality of storage devices, wherein at least one of the plurality of storage devices has erase blocks mapped as directly addressable storage; and

storing the data in a second non-volatile fast-write portion of a second storage device of the plurality of storage devices, wherein the first storage portion and the second non-volatile fast-write portion are separately addressable.

19. The method of claim 18, further comprising mapping memory addresses of the second non-volatile fast-write portion of the second storage device to logic on the storage system controller.

20. The method of claim 18, further comprising: detecting a failure to the plurality of storage devices; and after resumption from the failure:

reading the data from the second non-volatile fast-write portion of the second storage device;

determining a recovery action based on the data; and performing the recovery action.

21. The method of claim 18, wherein performing the recovery action comprises copying the data from the second non-volatile fast-write portion of the second storage device to a third direct-mapped solid state drive (SSD) storage portion of the second storage device.

22. The method of claim 18, wherein the first storage device and the second storage device are a same storage device.

* * * * *