

June 7, 1932.

W. H. JAYNE

1,862,404

BRUSH HOLDER

Filed March 19, 1931

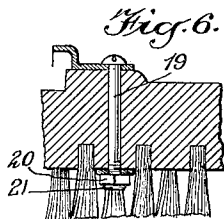
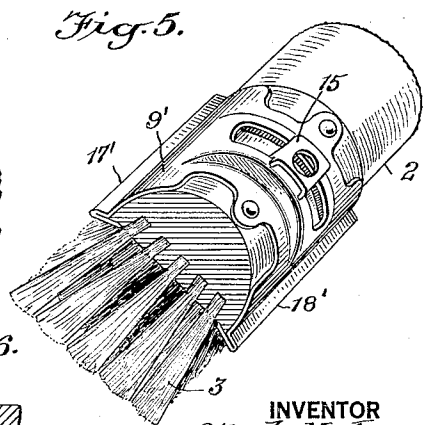
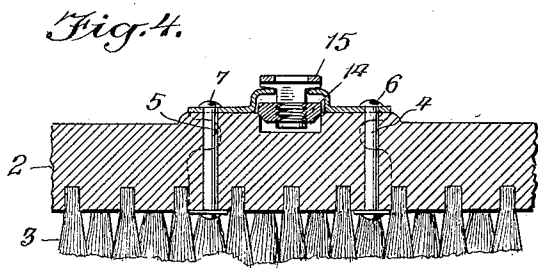
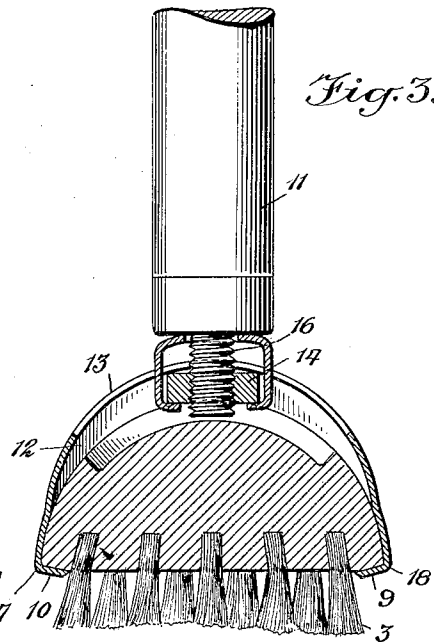
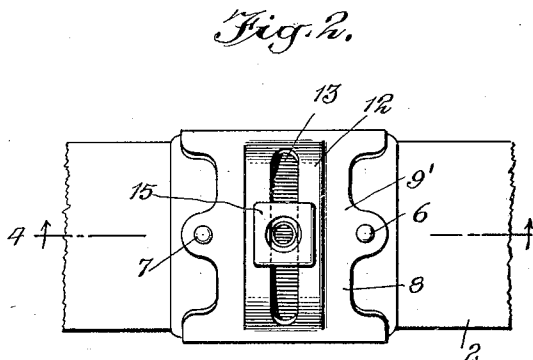
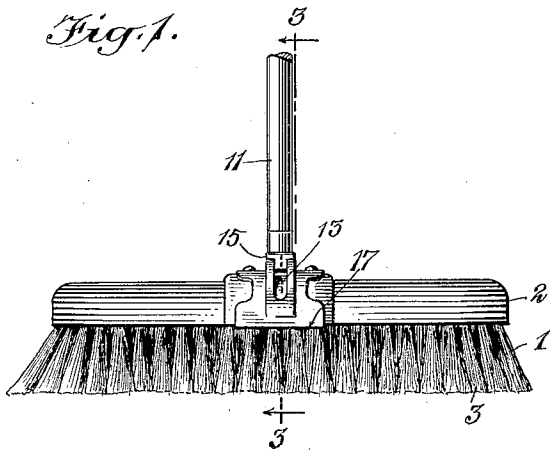

WITNESSES
Geo. W. Taylor
A. L. Ritchie

INVENTOR
Wade H. Jayne
BY
Mumford
ATTORNEYS

UNITED STATES PATENT OFFICE

WADE H. JAYNE, OF NEW YORK, N. Y.

BRUSH HOLDER

Application filed March 19, 1931. Serial No. 523,861.

This invention relates to brush holders and particularly to a holder which is an improvement over my prior Patent No. 1,775,558. The object of the invention is to provide an improved holder which will be strong and which can be readily attached to a brush having a wooden back without weakening the back.

Another object of the invention is to provide a brush holder which will strengthen the block or back of the brush but permitting a proper actuation thereof at all times.

An additional object is to provide a brush holder which acts to strengthen the block or back of the brush and also presents means which may be used as scrapers.

In the accompanying drawing—

Figure 1 is a front view of a brush with a holder embodying the invention applied thereto.

Figure 2 is a top plan view of the center part of the structure shown in Figure 1, the same being on an enlarged scale and the handle being removed.

Figure 3 is a sectional view through Figure 1 on line 3—3, the same being on an enlarged scale.

Figure 4 is a sectional view through Figure 2 on line 4—4.

Figure 5 is a perspective view of part of the brush and a modified form of holder to that shown in Figure 1.

Figure 6 is a fragmentary sectional view similar to Figure 4, but showing a modified form of holder retaining member.

Referring to the accompanying drawing by numeral, 1 indicates a brush of a well-known kind provided with a back or block 2 and bristles 3. Heretofore, in many instances, the block 2 which is made of wood was bored centrally for receiving a handle. This weakened the block, and quite often caused the same to break, and also it has been found difficult to maintain the handle connected with the block in this manner. In the present instance, the block 2 is left untouched as far as the holder is concerned, except two small holes 4 and 5 as shown in Figure 4, said holes accommodating the rivets 6 and 7 which extend through the center part of the

block as illustrated in Figure 2, and are upset or riveted at each end for firmly clamping the holder 8 in place. The holder 8 is provided with a body 9' fitting flatwise over the outer surface of block 2 and provided with inturned flanges 9 and 10 (Figure 3) which are positioned to press against the lower surface of the block, for strengthening the block, and for retaining the holder in place. The rivets 4 and 5 are comparatively small and while they act to assist in holding the holder in position on the block 2, they are intended primarily to prevent longitudinal slipping of the holder while the flanges 9 and 10 take up the strain between the block 2 and the handle 11. The body 9' is provided with a pressed-out portion 12 having a slot 13 which accommodates the nut 14, which nut is carried by the clamping frame 15. This construction is old and well-known as far as this application is concerned as it is fully shown and claimed in my prior patent above referred to.

The handle 11 is provided with a threaded member 16 which is adapted to be screwed into nut 14 and when properly tightened will cause the nut to press against the under surface of the pressed out portion 12 and thereby hold the handle 11 in any desired position as, for instance, that shown in Figure 3. If it is desired to move the handle to a different angle as for instance to a position opposite one end of the slot 13, handle 11 is unscrewed slightly, or until the nut 14 has become loosened and is then swung over to a desired position, after which it is again tightened. In this way, the handle 11 may be removably connected with the brush 1 without injuring the block 2 but on the other hand present means for strengthening this block centrally.

It will be understood that the body 9' is made from metal and is pressed to snugly fit the outer surface of the block 2. When the brush is in use, ordinarily the handle 11 extends from one end of the slot 13 so as to be at a proper angle for sweeping. At this angle or some other angle, the brush may function in the usual manner. In case a sticky or hard object is encountered during

- the brushing operation the brush may be turned over and either of the edges 17 or 18 used as a scraper for scraping the objectionable matter. After the objectionable matter has been loosened, the brush is turned back into its usual position and then the bristles 3 may function in the usual manner. The edges 17 and 18 normally will be satisfactory for the ordinary scraping action necessary in some circumstances, it may be desirable to have a slightly better scraping action and when this is the case, the modified form shown in Figure 5 is used. As shown in Figure 5, the body 9' is provided with extensions 17' and 18' instead of the comparatively sharp edges 17 and 18 as shown in Figure 3. This presents a greater scraping structure and may be preferable in factories and elsewhere where lumps and objectionable matter is found on the floor. It will be noted that in all forms of the invention, there are no screw or large holes which have been used heretofore in providing means for connecting a handle to the brush.
- In Figure 6 a slightly modified form of the invention is shown to that shown in Figure 4, wherein bolts 19 are used instead of the rivets as shown in Figure 4. These bolts naturally carry suitable nuts 20 which may be screwed down tight to clamp the parts rigidly in place. Preferably the end 21 is also upset so that the nuts 20 cannot come off accidentally.
- I claim:
1. A brush holder for a brush having a wood back comprising a single piece metallic body adapted to fit over said back, said body being formed with inturned flanges at the front and rear edges positioned to extend beneath said back, each of said flanges having an outwardly extending portion acting as a scraper and means for connecting a handle to said body.
 2. A brush and a holder comprising a brush structure having a back and a metallic body partly enclosing the center of the back, said body having an extension at the front and rear for the full length of the holder, said extensions being bent back on themselves for forming gripping flanges underlapping the body and scrapers projecting beyond the body.
 3. A brush holder comprising a body adapted to encircle the back of a brush, said body being provided with an extension bent back upon itself for forming a retaining flange engaging the brush back, and a projection presenting a scraper, and means coacting with the body for securing the handle thereto.
 4. In a brush, a brush back, a metallic body fitted against the back centrally thereof and a handle connected with said body, said body substantially at the bottom surface of the brush back being formed with edge extensions projecting beyond said brush back on the front and rear edges, each of said extensions being bent back upon itself with the bent-back portions acting as flanges engaging said brush back while the extensions at their respective points of bending act as scrapers.
 5. A holder for the wooden back of a brush comprising a body substantially fitting the top surface of said back and extending to the lower surface; said body at said lower surface being formed with inwardly extending flanges on each edge positioned to press against the under surface of the back for clamping the body to the back, said body at the juncture thereof with the flanges extending outwardly and forming scrapers.

WADE H. JAYNE.