

(19)



(11)

EP 1 905 917 A1

(12)

EUROPEAN PATENT APPLICATION

(43) Date of publication:
02.04.2008 Bulletin 2008/14

(51) Int Cl.:
E04D 1/34 (2006.01)

(21) Application number: **07116070.9**

(22) Date of filing: **11.09.2007**

(84) Designated Contracting States:
**AT BE BG CH CY CZ DE DK EE ES FI FR GB GR
 HU IE IS IT LI LT LU LV MC MT NL PL PT RO SE
 SI SK TR**
 Designated Extension States:
AL BA HR MK YU

(71) Applicant: **Bove Holding B.V.
5371 EV Ravenstein (NL)**

(72) Inventor: **Bogaerts, Albert Felix Joseph
5371 PJ, Ravenstein (NL)**

(30) Priority: **12.09.2006 NL 2000230**

(74) Representative: **Ketelaars, Maarten F.J.M.
Nederlandsch Octrooibureau
Postbus 29720
2502 LS Den Haag (NL)**

(54) **Tile hook, pitched roof and method for covering a pitched roof**

(57) A tile hook for the fastening of a number of roof tiles, attached to a pitched roof, to a tile lath comprises a hook part which is provided at one end with fastening means which can be fastened to a tile lath. The tile hook also has a clamping part which is attached to the end of the hook part that opposes the fastening means. The

clamping part is provided with a plate-like top which can engage with the upper surface of two roof tiles positioned diagonally opposing each other. The plate-like top and the hook part form two separately manufactured components which may or may not be detachably fastened to each other. The hook part is resilient and the plate-like top is more rigid than the hook part.

Fig 2

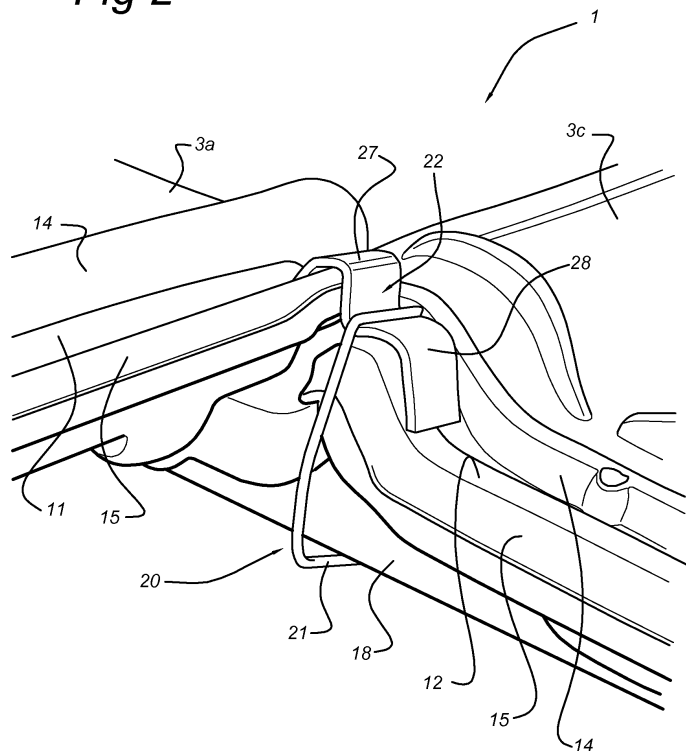

EP 1 905 917 A1

Description

[0001] The invention relates to a tile hook for the fastening of a number of roof tiles, attached to a pitched roof, to a tile lath, comprising a hook part which is provided at one end with fastening means which can be fastened to a tile lath, for example by engagement with the tile lath, and also a clamping part which is attached to the end of the hook part that opposes the fastening means, the clamping part being provided with a plate-like top which can engage with the upper surface of two roof tiles positioned, preferably diagonally, opposing each other, and the plate-like top and the hook part forming two separately manufactured components which may or may not be detachably fastened to each other, and the hook part being resilient and the plate-like top being more rigid than the hook part.

[0002] Roof tiles for a pitched roof are generally known. These roof tiles are attached in overlapping rows, located one above the other, to tile laths of the roof by means of tile hooks. The tile hooks are made, for example, by bending a strip of steel. In roof tiles, a distinction can be drawn between what are known as VH tile locking and OVH tile locking.

[0003] The roof tiles with VH locking are laid in a row from left to right, whereas the side edges of the tiles overlap one another. Subsequently, a row of roof tiles which is located thereabove is attached and the lower edges of these tiles overlap the upper edges of the underlying row of roof tiles. A tile hook then clamps a roof tile from the upper row to a tile lath. This secures the roof tile located therebelow and the roof tile adjoining said underlying roof tile on the left-hand side. After all, these roof tiles overlap one another. In view of the fact that the tile hook for roof tiles with VH locking has to secure merely one roof tile, what is known as a "single" tile hook is usually used. This tile hook has merely one protruding lip which can engage with a roof tile.

[0004] In contrast to the VH tiles, roof tiles with OVH locking have recesses at corners positioned diagonally opposing each other, generally in the top-right corner and the bottom-left corner. These roof tiles with OVH locking are usually also laid from left to right, although the right tiles are positioned, laterally overlapping one another, below the left tiles. A roof tile from an upper row also overlaps the roof tile positioned immediately therebelow. However, as a result of the recesses, said tile from an upper row does not overlap or hardly overlaps the roof tile located to the left of said roof tile positioned immediately therebelow. Therefore, for roof tiles with OVH locking, use is made of a "double" tile hook which secures both the roof tile positioned in the top right and that positioned in the bottom left. This "double" tile hook ensures that the roof tiles do not blow off under the influence of suction during a storm.

[0005] There are many different types of roof tiles, in particular roof tiles with OVH locking. For example, the thickness of the tile and the height of the undulation vary,

as a result of which the distance from the upper surface of the tile to the tile lath may be different for each type of roof tile. In addition, the locking grooves in the tile, which also form water-retaining structures, may be located closer together or further apart from one another in one roof tile than in another roof tile. An accompanying tile hook is thus required for each type of roof tile.

[0006] However, the dimensions of some roof tiles are such that a sufficiently strong tile hook cannot be designed. The locking grooves in the tile are, for example, too wide. Were the protruding lips of the tile hook to extend over the entire width of the locking groove, said lips would be so long that they would buckle during a storm. Nor is it possible to shorten the protruding lips, because this would allow the roof tiles to become detached during a storm.

[0007] The object of the invention is to provide an improved tile hook, in particular for roof tiles with OVH locking, that is preferably suitable for almost any type of roof tile, is simple to install and/or provides sufficient protection against blowing-off.

[0008] According to the invention, this object is achieved by a tile hook according to Claim 1.

[0009] The clamping part of the tile hook according to the invention is formed by a plate-like top which is made independently of the hook part. The clamping part according to the invention can be designed independently of the hook part. This allows the hook part and the clamping part to be optimised - each component can be designed specifically for the independent purpose thereof. As the plate-like top has a curved profile shape which is adapted to the shape of the engaged upper surface of the roof tiles, the plate-like top fits the roof tiles precisely. In addition, the profile shape increases the rigidity of the plate-like top, thus allowing the roof tiles to be clamped securely.

[0010] The plate-like top has, for example, two protruding lips which protrude laterally on opposing sides of the hook part. The shape and dimensions of said lips can be adapted to each roof tile. In addition, it is possible to make said lips sufficiently strong, for example by forming the plate-like top with a relatively thick profile, while the hook part remains somewhat resilient - the hook part is, for example, filamentary. The tile hook according to the invention can therefore be made suitable for almost any type of roof tile without adversely affecting the ease of use and/or protection against blowing-off.

[0011] It should be noted that a tile hook for slates is known from FR2566446. However, the plate-like top of this tile hook does not have a curved profile shape. This tile hook is therefore unsuitable for use in roof tiles, especially if the roof tiles are provided with locking grooves.

[0012] Preferably, the hook part and the clamping part according to the invention are secured to each other, for example by welding. However, it is possible for the hook part and the clamping part to be clamped to the roof as loose components. The plate-like top and the hook part may or may not be detachably fastened to each other.

[0013] The invention also relates to a pitched roof provided with a covering of roof tiles which rest on tile laths and overlap one another in a roof slope direction and a lateral direction extending transversely to the roof slope, which roof tiles are fastened to the tile laths by means of tile hooks, which tile hooks are each provided with a hook part provided at one end with fastening means, which can be fastened to the tile lath, and a clamping part attached to the end of the hook part that opposes the fastening means. According to the invention, the clamping part is provided with a plate-like top which engages with the upper surface of two roof tiles positioned, preferably diagonally, opposing each other, and the plate-like top has a curved profile shape which is adapted to the shape of said roof tiles, and the plate-like top and the hook part form two separately manufactured components which may or may not be detachably fastened to each other, and the hook part is resilient and the plate-like top is more rigid than the hook part.

[0014] The hook part and the plate-like top can be made of differing materials. For example, the hook part is made of steel, for example spring steel wire, and the plate-like top is made of aluminium. The manufacturing costs of a profiled plate-like top made of aluminium are relatively low, whereas the spring steel wire of the hook part provides sufficient resilience in combination with high tensile strength. However, the hook part and the plate-like top can also be made of the same material, for example both of steel.

[0015] The tile hook according to the invention is especially suitable for OVH tiles. The roof tiles of the roof according to the invention then each have, at two corners diagonally opposing each other, a recess, wherein a lower edge of a first roof tile overlaps an upper edge of a second roof tile located below the first roof tile in the roof slope direction, and wherein a side edge of a third roof tile, which is located adjacently to the second roof tile in the lateral direction, overlaps the adjoining side edge of the second roof tile, and wherein the plate-like top engages with the side edge of the first roof tile and with the side edge of the third roof tile.

[0016] According to the invention, it is also possible that the roof tiles each have, on the upper surface thereof, a lateral locking groove and a crosscut or head locking groove, the locking grooves each being delimited by an inner and outer upright rib, and wherein the plate-like top has a profile shape substantially corresponding to the outer upright rib of a first roof tile and to the outer upright rib of a roof tile positioned diagonally therebelow. The lateral and crosscut or head locking grooves in the upper surface can cooperate with the side edge and the crosscut or head edge, respectively, of the lower surface of an adjacent, upper roof tile. The use of a head and side lock simplifies the laying of the roof tiles.

[0017] In a preferred embodiment, the first roof tile is displaceable in the roof slope direction below the profile shape of the plate-like top. This is beneficial to compensate for differences in the dimensions of roof tiles. An

amount of roof tiles intended for a roof, i.e. of tiles of a single type, can differ from one another as a result of the production process of the tiles. The dimensions of roof tiles for a single roof are not precisely identical. In order to make the roof tiles fit when tiling a roof, it is therefore beneficial for the profile shape of the clamping part to be designed in such a way that the roof tile "clamped" therebelow can move somewhat. A clearance is, for example, provided for this purpose between the clamping part and this roof tile.

[0018] In addition, according to the invention, it is preferable for a clearance to be provided between the profile shape of the plate-like top and the third roof tile such that the third roof tile is to some extent movable in the lateral direction in relation to the second roof tile. A roofer can pull the second and third roof tile from the same row apart from one another or push them together when laying the roof tiles. This is especially advantageous.

[0019] In one embodiment of the invention, the tile hook can be attached to the tile lath by a snap connection, the two roof tiles positioned diagonally in relation to each other being secured. A roofer inserts the tile hook from the upper surface between the roof tiles. Tilting the tile hook causes the hook part then to grip behind the tile lath.

[0020] In order to provide the snap connection, the hook part of the tile hook has, for example, a first shank part running substantially in the roof slope direction below the tile lath and a second shank part extending substantially perpendicularly to the roof surface between the first shank part and the top. The first shank part and/or the second shank part can have a kink which makes the tile hook resilient. The fastening means are, in this case, provided, for example, with a hook member for engaging with a tile lath, in particular with the front surface, extending in the lateral direction and remote from the ridge, of the tile lath. Tilting the tile hook causes said hook member to snap behind the tile lath.

[0021] The invention also relates to a method for the covering of a pitched roof with roof tiles, the tile hook and/or the pitched roof being configured as described hereinbefore.

[0022] The invention will now be described in greater detail with reference to an illustrative embodiment shown in the figures, in which:

Figure 1 is a plan view of a pitched roof according to the invention, just three roof tiles being shown for the sake of clarity;

Figure 1a shows a detail from Figure 1;

Figure 2 is a perspective side view of the roof tiles shown in Figure 1;

Figure 3 is a perspective view from below of the roof tiles shown in Figure 1; and

Figure 4 is a cross section along the line IV-IV in

Figure 2.

[0023] The pitched roof according to the invention is denoted in its entirety in the figures by reference numeral 1. The pitched roof 1 comprises roof tiles which are attached in rows, which are positioned one above another and overlap in two directions, of the roof. In Figure 1, just three roof tiles 3a, 3b, 3c are shown for the sake of clarity of the drawing. Each roof tile 3a, 3b, 3c has a lower edge 7, an upper edge 8 and two opposing side edges 9.

[0024] Along the upper edge 8, each roof tile 3a, 3b, 3c has, on the upper surface thereof, a crosscut or head locking groove 12 (see Figure 1 a). On the left side edge 9, the roof tiles 3a, 3b, 3c each have a lateral locking groove 11 in the upper surface. The roof tiles 3a, 3b, 3c are each provided in the top right-hand corner and the bottom left-hand corner with a recess 5 and 6 respectively. The locking grooves 11, 12 are formed by upright ribs 14, 15 extending parallel to each other and set apart from each other.

[0025] As is shown most clearly in Figure 3, each roof tile 3a, 3b, 3c has, on the lower surface thereof, one or more support ridges 17. The support ridges 17 rest on tile laths 18 extending in the lateral direction on the pitched roof 1.

[0026] The lower edge 7 of the roof tile 3a, shown in the top right in Figure 1, overlaps the upper edge 8 of the roof tile 3b positioned directly therebelow. The lower surface of the lower edge 7 of the roof tile 3a cooperates in a substantially interlocking manner with the crosscut groove 12 in the roof tile 3b. In addition, the right side edge 9 of the roof tile 3c, adjoining the roof tile 3b of the same row, overlaps the left side edge 9 of said roof tile 3b. In this case, the lower surface of the right side edge 9 of the roof tile 3c and the lateral locking groove 11 in the roof tile 3b are connected in a substantially interlocking manner. The corner recesses 5, 6 in the roof tiles 3a and 3c respectively then fit together. Play allows the roof tiles 3a, 3b, 3c to move in the head and side lock relative to one another.

[0027] A tile hook 20 is provided for securing the roof tiles 3a, 3b, 3c to the tile lath 18. In this illustrative embodiment, the tile hook 20 has a filamentary hook part 21 and a clamping part 22. The hook part 21 comprises a first shank part 24 running below the tile lath 18 the first shank part 24 extends in the roof slope direction. At the end of the first shank part 24 there is located a hook member for engaging with the front surface, remote from the ridge, of the tile lath 18. The first shank part 24 is integrated with a second shank part 25 extending substantially perpendicularly to the roof surface. As shown in Figures 2 and 3, the second shank part runs over the head of the roof tile 3c. On the upper side, the second shank part 25 is bent transversely.

[0028] The hook part 21 is resilient. The hook part 21 is, for example, made by bending spring steel wire or a steel wire or rod. To increase the resilience, a kink is in each case formed in the first shank part 24 and the sec-

ond shank part 25. Because the hook part 21 is resilient, the tile hook is able to clamp the roof tiles 3a, 3b, 3c if suction is exerted on said roof tiles 3a, 3b, 3c during a storm. In addition, fitting the tile hook 20 is simple owing to the resilient configuration of the hook part 21. For this purpose, the tile hook 20 is brought over the head of the roof tile 3c, the hook member engaging or snapping behind the front surface of the tile lath 18.

[0029] The tile hook 20 comprises a clamping part 22 fastened to the second shank part 25 of the hook part 21, for example by welding. The clamping part 22 forms a plate-like top which can engage with the roof tiles 3a, 3c. For this purpose, the plate-like top 22 has two gripping lips 27, 28 which protrude laterally on opposing sides of the hook part 21. The shape of the first gripping lip 27 is adjusted in a substantially well-fitted manner to the outer upright rib 15 on the left side edge 9 of the roof tile 3a (see Figure 4).

[0030] Nevertheless, there is still some space between the first gripping lip 27 and the roof tile 3a. The roof tile 3a can move through the first gripping lip 27 to allow play of the roof tiles in the roof slope direction.

[0031] The second gripping lip 28 can clamp the roof tile 3c - after all, the roof tile 3c cannot be pulled perpendicularly from the surface of the roof, for example during a storm. The second gripping lip 28 has a shape substantially corresponding to the right-hand portion of the upper edge 8 of the roof tile 3c. However, a clearance 30 is left therebetween (see Figure 4). As a result, the roof tile 3c is able to move somewhat in the lateral direction in relation to the roof tiles 3a, 3b. In Figure 4, this is indicated schematically by a dot-dash line.

[0032] In this illustrative embodiment, the plate-like top 22 is formed by a strip of aluminium bent into the desired shape. In fact, the plate-like top 22 can be formed in various ways, for example by a profile member such as an extrusion profile member. The thickness and the material of the plate-like top 22 are a design parameter which is independent of the shape, the dimensions and the material of the hook part 21. According to the invention, the plate-like top 22 and the hook part 21 can be optimised for any type of roof tile.

[0033] The plate-like top 22 also has stiffening ribs (not shown) running in the lateral direction. The stiffening ribs impart to the plate-like top 22 sufficient strength and rigidity, while the weight thereof can remain relatively low.

[0034] Once a roofer has placed the roof tiles 3a, 3b, 3c one overlapping another, he inserts the tile hook 20 over the upper edge 8 between the roof tiles. In this case, he lays the plate-like top 22 on the outer upright rib 15 of the roof tile 3a and the right-hand portion of the top upright rib 15 on the upper edge 8 of the roof tile 3c, after which he engages the hook part 21 of the tile hook 20 with the hook member behind the tile lath 18. The spring force in the hook part 21 causes the hook member to spring behind the tile lath 18. The roofer can hear this, so he knows that the tile hook 20 has been positioned correctly.

[0035] Obviously, the invention is not limited to the illustrative embodiment shown in the figures. A person skilled in the art may carry out various adaptations which are within the scope of the invention. For example, the measure according to which the plate-like top has a curved profile shape, which is adapted to the shape of the roof tiles to be engaged, can be omitted in Claims 1 and 6.

Claims

1. Tile hook for the fastening of a number of roof tiles (3a, 3b, 3c), attached to a pitched roof, to a tile lath (18), comprising a hook part (21) which is provided at one end with fastening means which can be fastened to a tile lath (18) and also a clamping part (22) which is attached to the end of the hook part (21) that opposes the fastening means, the clamping part (22) being provided with a plate-like top which can engage with the upper surface of two roof tiles (3a, 3c) positioned diagonally opposing each other, and the plate-like top and the hook part (21) forming two separately manufactured components, and the hook part (21) being resilient and the plate-like top (22) being more rigid than the hook part (21), **characterised in that** the plate-like top (22) has a curved profile shape which is adapted to the shape of the roof tiles (3a, 3b, 3c) to be engaged.
2. Tile hook according to Claim 1, wherein the plate-like top (22) extends laterally on opposing sides of the hook part (21).
3. Tile hook according to either Claim 1 or Claim 2, wherein the hook part (21) is filamentary.
4. Tile hook according to any one of the preceding claims, wherein the hook part (21) and the plate-like top (22) are made of differing materials.
5. Tile hook according to Claim 4, wherein the hook part (21) is made of steel, for example spring steel wire, and wherein the plate-like top (22) is made of aluminium.
6. Pitched roof provided with a covering of roof tiles (3a, 3b, 3c) which rest on tile laths and overlap one another in a roof slope direction and a lateral direction extending transversely to the roof slope, which roof tiles (3a, 3b, 3c) are fastened to the tile laths (18) by means of tile hooks (20), which tile hooks (20) are each provided with a hook part (21) provided at one end with fastening means, which can be fastened to the tile lath (18), and a clamping part (22) attached to the end of the hook part (21) that opposes the fastening means, **characterised in that** the clamping part (22) is provided with a plate-like top

which engages with the upper surface of two roof tiles (3a, 3c) positioned diagonally opposing each other, and the plate-like top (22) has a curved profile shape which is adapted to the shape of said roof tiles (3a, 3b), and the plate-like top (22) and the hook part (21) form two separately manufactured components, and the hook part (21) is resilient and the plate-like top (22) is more rigid than the hook part (21).

7. Pitched roof according to Claim 6, wherein the roof tiles (3a, 3b, 3c) each have, at two corners diagonally opposing each other, a recess (5, 6), and wherein a lower edge (7) of a first roof tile (3a) overlaps an upper edge (8) of a second roof tile (3b) located below the first roof tile (3a) in the roof slope direction, and wherein a side edge (9) of a third roof tile (3c), which is located adjacently to the second roof tile (3b) in the lateral direction, overlaps the adjoining side edge (9) of the second roof tile (3b), and wherein the plate-like top (22) engages with the side edge (9) of the first roof tile (3a) and with the upper edge (8) and/or the side edge (9) of the third roof tile (3c).
8. Pitched roof according to Claim 6 or Claim 7, wherein the roof tiles (3a, 3b, 3c) each have, on the upper surface thereof, a lateral locking groove (11) and a crosscut or head locking groove (12), the locking grooves (11, 12) each being delimited by an inner and outer upright rib (14, 15), and wherein the profile shape of the plate-like top (22) substantially corresponds to an outer upright rib (15) of a first roof tile (3a) and to an outer upright rib (15) of a roof tile (3c) positioned diagonally therebelow.
9. Pitched roof according to Claim 8, wherein the first roof tile (3a) is displaceable in the roof slope direction below the profile shape of the plate-like top (22).
10. Pitched roof according to Claim 7 or Claim 8, wherein a clearance (30) is provided between the profile shape of the plate-like top (22) and the third roof tile (3c) such that the third roof tile (3c) is to some extent movable in the lateral direction in relation to the second roof tile (3b).
11. Pitched roof according to any one of Claims 6 to 10, wherein the tile hook (20) can be attached to the tile lath (18) by a snap connection, the two roof tiles (3a, 3c) positioned diagonally in relation to each other being located between the plate-like top (22) and the tile lath (18).
12. Pitched roof according to any one of Claims 6 to 11, wherein the hook part (21) of the tile hook (20) is provided with a first shank part (24) running substantially in the roof slope direction below the tile lath (18) and a second shank part (25) extending substantially perpendicularly to the roof surface between the first

shank part (24) and the top (22).

- 13.** Pitched roof according to Claim 12, wherein the first shank part (24) and/or the second shank part (25) has a kink which makes the tile hook (20) resilient. 5
- 14.** Pitched roof according to any one of Claims 6 to 13, wherein the fastening means are provided with a hook member for engaging with a tile lath (18), in particular with the front surface, extending in the lateral direction, of the tile lath (18). 10
- 15.** Method for the covering of a pitched roof (1) according to any one of Claims 6 to 14. 15

20

25

30

35

40

45

50

55

Fig 1

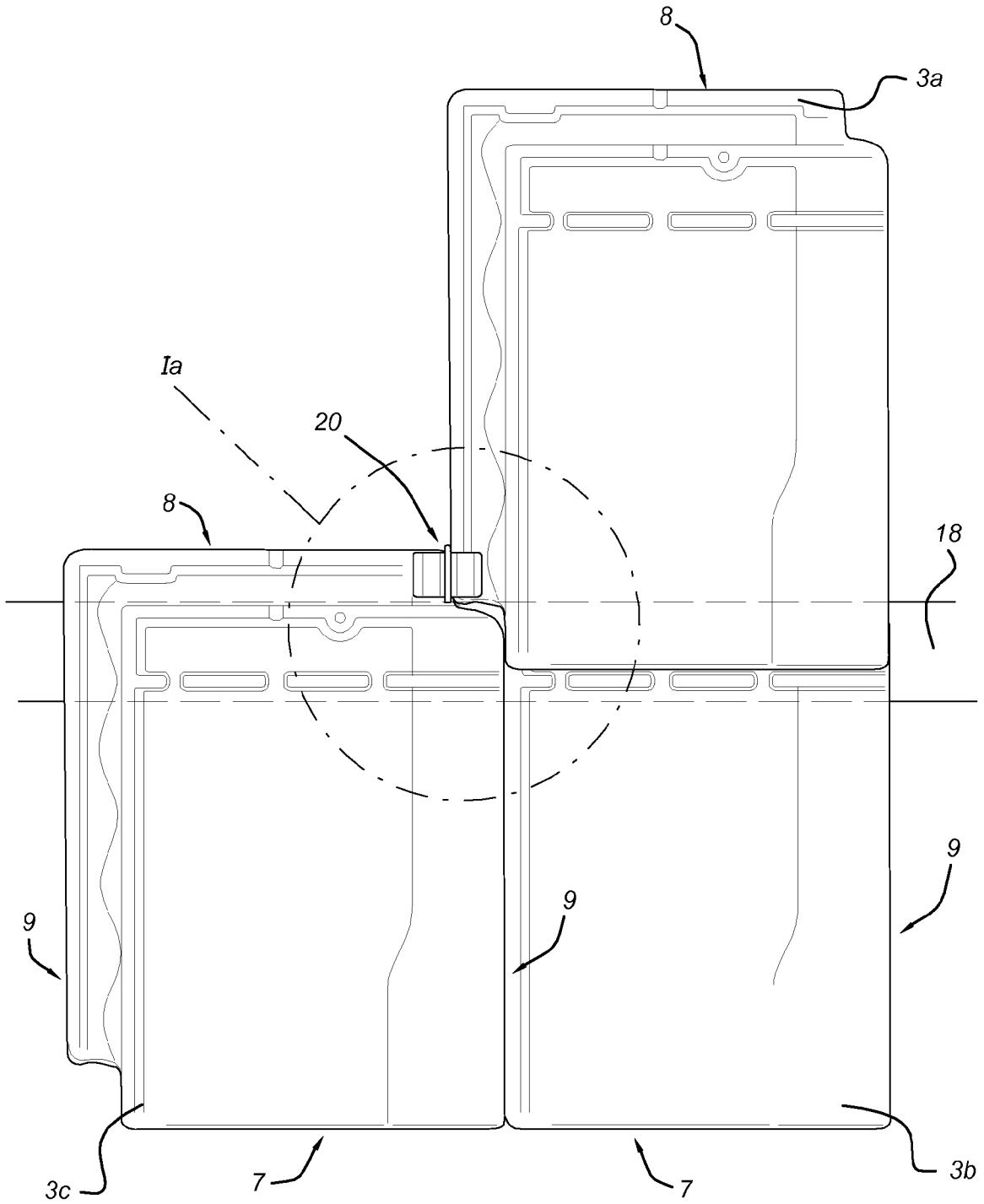

Fig 2

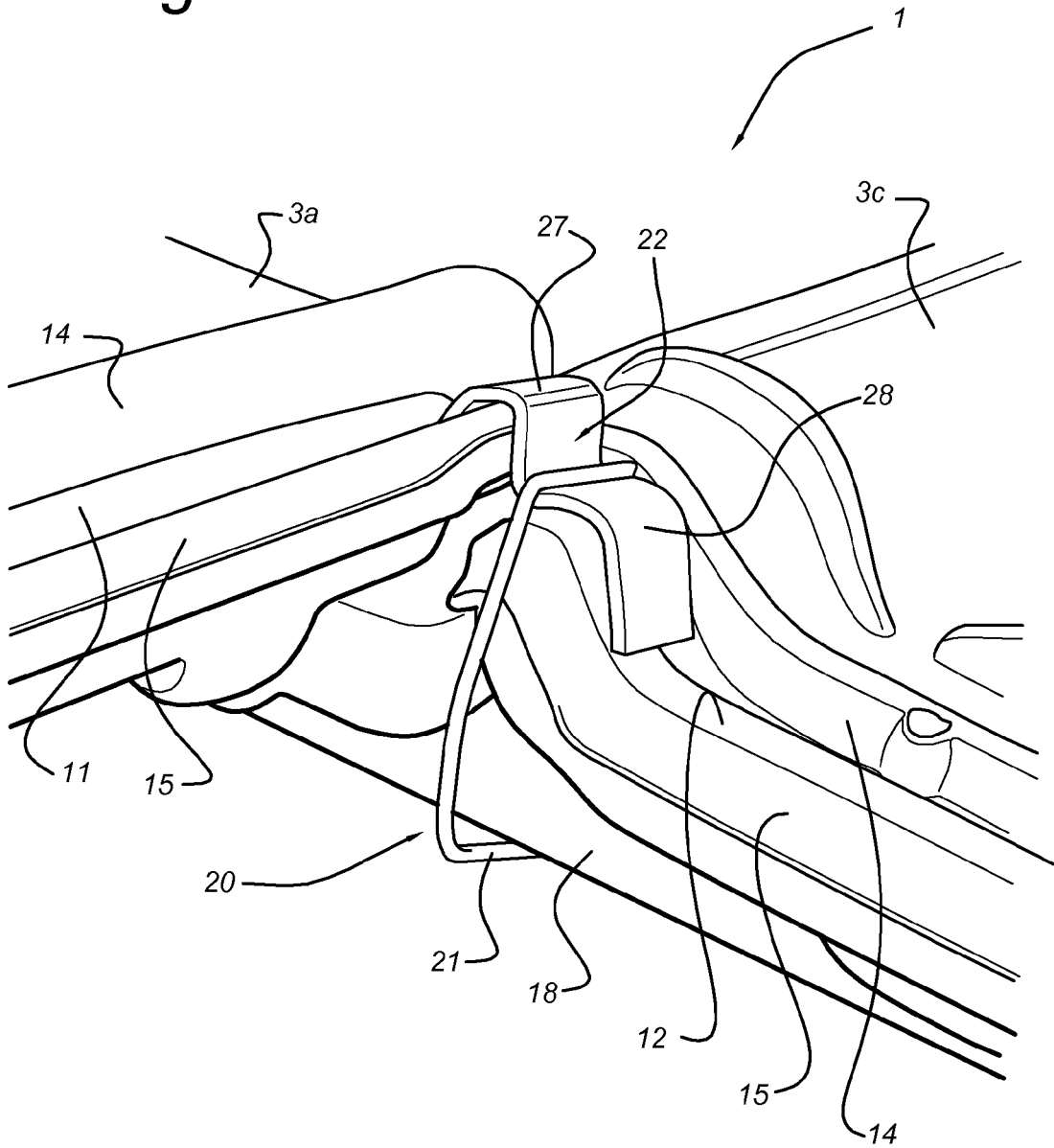

Fig 3

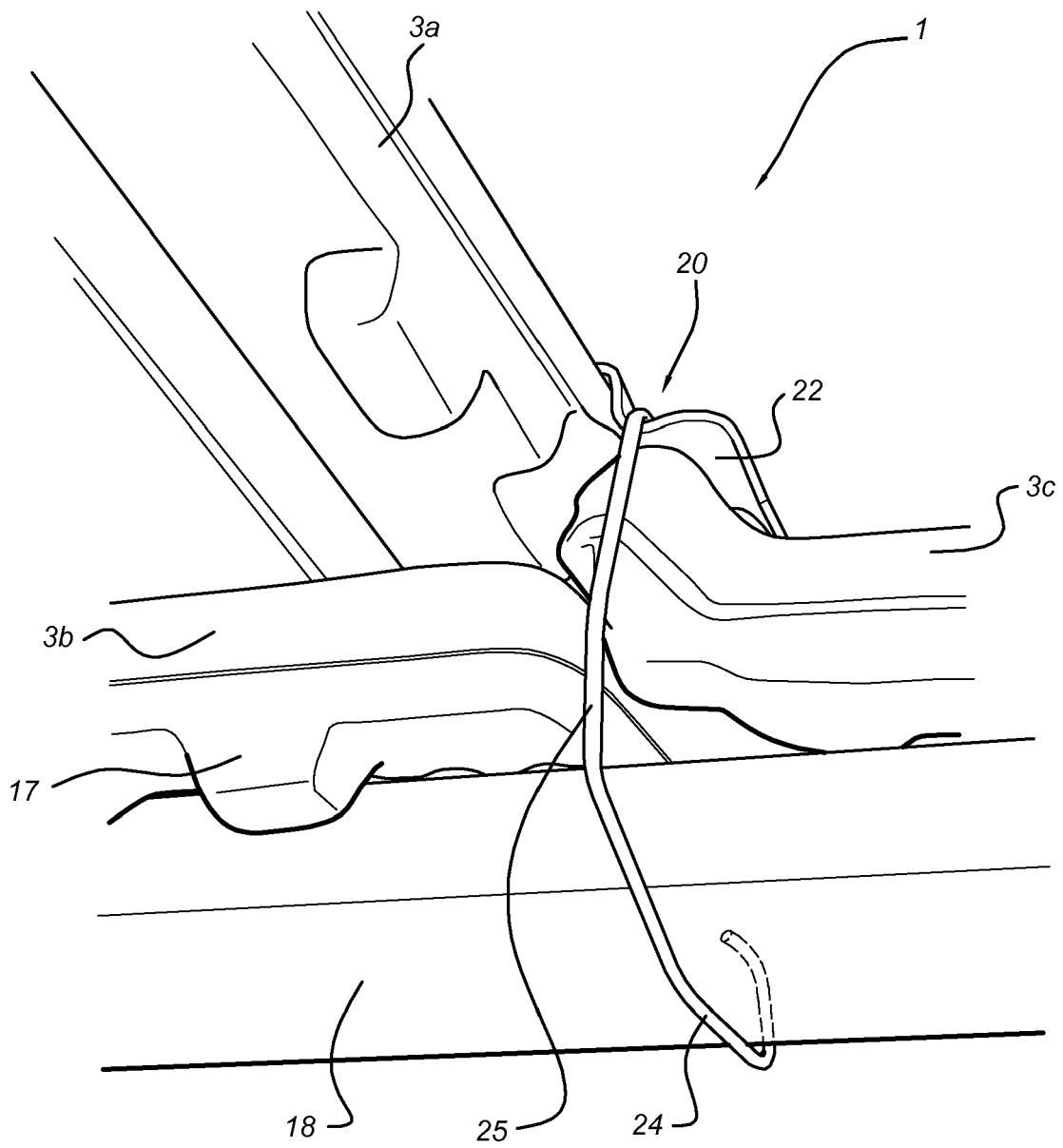
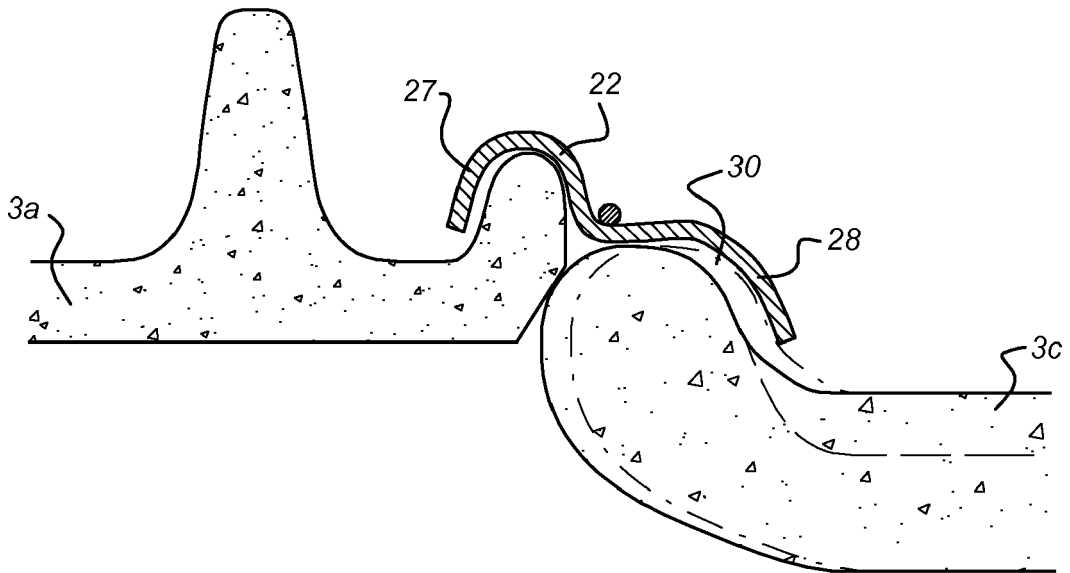

Fig 4





DOCUMENTS CONSIDERED TO BE RELEVANT			
Category	Citation of document with indication, where appropriate, of relevant passages	Relevant to claim	CLASSIFICATION OF THE APPLICATION (IPC)
X	DE 43 07 982 A1 (BRAAS GMBH [DE]) 15 September 1994 (1994-09-15) * figure 1 *	1-5	INV. E04D1/34
X	DE 299 00 859 U1 (OSSENBERG SCHULE & SOEHNE [DE]) 6 May 1999 (1999-05-06) * figure 2 *	1-5	
Y	EP 0 870 884 A (REDLAND DAKPROD BV [NL]) 14 October 1998 (1998-10-14) * figures 2,3 *	6,7, 10-15	
Y	DE 298 04 195 U1 (OSSENBERG SCHULE & SOEHNE [DE]) 28 May 1998 (1998-05-28) * figure 2 *	1-6, 10-15	
			TECHNICAL FIELDS SEARCHED (IPC)
			E04D
The present search report has been drawn up for all claims			
2	Place of search The Hague	Date of completion of the search 20 February 2008	Examiner Demeester, Jan
CATEGORY OF CITED DOCUMENTS		T : theory or principle underlying the invention E : earlier patent document, but published on, or after the filing date D : document cited in the application L : document cited for other reasons & : member of the same patent family, corresponding document	
X : particularly relevant if taken alone Y : particularly relevant if combined with another document of the same category A : technological background O : non-written disclosure P : intermediate document			

EPO FORM 1503 03.82 (P04/C01)

**ANNEX TO THE EUROPEAN SEARCH REPORT
ON EUROPEAN PATENT APPLICATION NO.**

EP 07 11 6070

This annex lists the patent family members relating to the patent documents cited in the above-mentioned European search report. The members are as contained in the European Patent Office EDP file on
The European Patent Office is in no way liable for these particulars which are merely given for the purpose of information.

20-02-2008

Patent document cited in search report	Publication date	Patent family member(s)	Publication date
DE 4307982 A1	15-09-1994	AT 140748 T	15-08-1996
		WO 9421870 A1	29-09-1994
		DK 688386 T3	02-12-1996
		EP 0688386 A1	27-12-1995
		ES 2091143 T3	16-10-1996
		FI 954267 A	09-11-1995
		HU 75624 A2	28-05-1997
		NO 953591 A	02-11-1995
		PL 311008 A1	22-01-1996
		SK 113095 A3	10-01-1996
-----	-----	-----	-----
DE 29900859 U1	06-05-1999	NONE	
EP 0870884 A	14-10-1998	DE 69823733 D1	17-06-2004
		DE 69823733 T2	28-04-2005
		NL 1005804 C2	14-10-1998
-----	-----	-----	-----
DE 29804195 U1	28-05-1998	BE 1012136 A3	02-05-2000
		CZ 9803085 A3	17-11-1999
		DK 126399 A	11-09-1999
		FR 2776002 A1	17-09-1999
		HU 9802049 A2	28-12-1999
		NL 1011198 C2	13-09-1999
		NO 984128 A	13-09-1999
		PL 330139 A1	13-09-1999
		SE 513748 C2	30-10-2000
		SE 9803113 A	11-09-1999
-----	-----	-----	-----

REFERENCES CITED IN THE DESCRIPTION

This list of references cited by the applicant is for the reader's convenience only. It does not form part of the European patent document. Even though great care has been taken in compiling the references, errors or omissions cannot be excluded and the EPO disclaims all liability in this regard.

Patent documents cited in the description

- FR 2566446 [0011]