



(12) **EUROPEAN PATENT APPLICATION**

(43) Date of publication:
26.03.2008 Bulletin 2008/13

(51) Int Cl.:
E05B 15/02^(2006.01) E05B 17/20^(2006.01)

(21) Application number: **07116101.2**

(22) Date of filing: **11.09.2007**

(84) Designated Contracting States:
AT BE BG CH CY CZ DE DK EE ES FI FR GB GR HU IE IS IT LI LT LU LV MC MT NL PL PT RO SE SI SK TR
 Designated Extension States:
AL BA HR MK YU

(72) Inventors:
 • **Saarinen, Jarmo**
FI-33880, Lempäälä (FI)
 • **Muurikainen, Petri**
FI-33710, Tampere (FI)

(30) Priority: **22.09.2006 FI 20065584**

(74) Representative: **Gustafsson, Aulis Valdemar**
AWEK Industrial Patents Ltd Oy
P.O. Box 230
00101 Helsinki (FI)

(71) Applicant: **Abloy Oy**
80100 Joensuu (FI)

(54) **Cover plate**

(57) A cover plate (1) according to the invention comprises a groove (5, 8, 9) arranged on the surface of the mounting cover that is to be fitted against the mounting base. The groove forms a loop so that it encircles the machined opening when the cover plate is fitted on the mounting base. There is a neck of material (7) between the bottom of the groove (5, 8, 9) and the front face of

the cover plate. If an attempt is made to pry the cover plate off the mounting base by inserting a tool such as a chisel between the mounting base and the edge of the cover plate, the neck of material between the bottom of the groove and the cover plate will give way, making the outer edge of the cover plate separate from the rest of the cover plate structure. The remaining cover plate structure does not provide any good support surface.

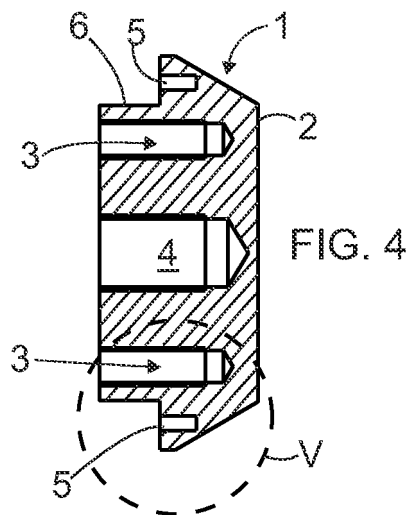

Description

Field of technology

[0001] The present invention relates to cover plates used in connection with locks on doors, hatches etc. Cover plates can be associated with handles, pulls, knobs, other lock accessories or cylinder bodies.

Prior art

[0002] Cover plates are used in connection with locks on doors, hatches etc. to cover machined openings made in the mounting base, for example a door. In some cases, mounting plates are used for attaching lock accessories. Machined openings are required for lock accessories and the cylinder body. In other words, machined openings are required for using the lock. Common lock accessories include a handle, a knob and a pull. A machined opening is often made through the door, creating holes on both sides of the door. When there are cover plates on opposite sides of the door to cover the machined opening, a normal way is to fasten the cover plates to each other using through-screws or through-bolts that make the cover plates press against the door. The fasteners - that is, the through-screws or through-bolts - are arranged to go through holes in the lock body within the door.

[0003] If the intention is to fit a handle with spindle into an opening made in the cover plate for the spindle, the plate is often called a handle plate. On the other hand, if the cover plate is intended for installation in connection with a cylinder body, it is often called a cylinder body plate or protective ring. A cover plate with no opening for a handle, cylinder body or other component is normally used for covering the machined opening on the opposite side of the door. The cover plate may also be designed for fitting a knob, in which case it is called a knob plate. Thus a cover plate generally refers to all types of cover plates that cover the machined opening made in the mounting base.

[0004] The purpose of cover plates is to protect the lock body and spindle within the door against external contamination and vandalism. A cover plate is also aesthetically more appealing than an open machined opening. Particularly in connection with external doors, a cover plate is required to have a protective effect against burglary. The burglar protection features of cover plates are already quite good but should be improved for particularly demanding installations.

Short description of invention

[0005] The objective of the invention is to improve the burglar protection features of cover plates. The purpose will be achieved as described in Claim 1. The other claims describe various embodiments of the invention.

[0006] A cover plate 1 according to the invention comprises a groove 5, 8, 9 arranged on the surface of the

mounting cover that is intended to be fitted against the mounting base. The groove forms a loop so that it encircles the machined opening when the cover plate is fitted on the mounting base. There is a neck of material 7 between the bottom of the groove 5, 8, 9 and the front face of the cover plate. If an attempt is made to pry the cover plate off the mounting base by inserting a tool such as a chisel or a crowbar between the mounting base and the edge of the cover plate, the neck of material between the bottom of the groove and the cover plate will give way, making the outer edge of the cover plate separate from the rest of the cover plate structure. The remaining cover plate structure does not provide any good support surface for burglars' tools.

List of figures

[0007] In the following, the invention is described in more detail by reference to the enclosed drawings, where

- Figure 1 illustrates an example of a cover plate viewed from the side of the front face,
 Figure 2 illustrates the example of Figure 1 viewed from the back side of the cover plate,
 Figure 3 illustrates the example of Figure 1 viewed from the side,
 Figure 4 illustrates the example of Figure 1 as a side cross-section,
 Figure 5 illustrates a detail of Figure 4,
 Figure 6 illustrates an embodiment of the groove, and
 Figure 7 illustrates another embodiment of the groove.

Description of the invention

[0008] Figure 1 illustrates an example of a cover plate 1 according to the invention viewed from the side of the front face 2. Figure 2 illustrates the same example viewed from the back, while Figure 3 illustrates it viewed from the side. In this embodiment, there are two threaded holes 3 for fasteners in a manner known from prior art. Screws and bolts are common fasteners. Furthermore, there is a threaded hole 4 for the spindle of a handle in the centre of the cover plate. Thus the cover plate in this example is intended for the opposite side of the door when the other side has a handle at the same machined opening. A cover plate according to the invention can naturally be implemented in some other way as well. The part of the cover plate that extends over the edge of the machined opening comprises a groove 5. The groove is arranged on the surface of the mounting cover that is intended to be fitted against the mounting base - that is, against the surface of the door. The groove forms a loop so that it encircles the machined opening when the cover plate is fitted on the mounting base.

[0009] Figure 4 illustrates a cross-section of the cover plate, while Figure 5 illustrates a detail of Figure 4. Between the bottom of the groove 5 and the front face 2 of

the cover plate there is a neck of material 7 that gives way when an attempt is made to pry the cover plate off the mounting base using a burglars' tool such as a crowbar. The intention is to insert a burglars' tool between the mounting base and the cover plate in order to have a good support surface for prying with the tool. However, the forming of a good support surface is deteriorated by the groove 5 and the fact that the neck 7 gives way, which makes it more difficult to pry the cover plate off the mounting base.

[0010] Figure 5 illustrates a groove 4 with a rectangular cross-section. Figure 6 illustrates a groove 8 with a triangular cross-section in which one of the apexes of the triangle forms the bottom of the groove. Figure 7 illustrates a groove 9 with a rounded bottom. As can be seen, there are many different embodiments of the groove. Groove shapes other than those illustrated in the figures can also be used.

[0011] In the examples illustrated in the figures, the cover plate also comprises an inlay part 6 arranged to be fitted into the machined opening in the mounting base. The inlay part 6 increases break-in security because it makes it more difficult to pry the cover plate 1 off the mounting base. However, a cover plate according to the invention can also be implemented without an inlay part.

[0012] It is evident from the above that the invention is not limited to the embodiments described in this text but can be implemented in many other different embodiments within the scope of the inventive idea.

Claims

1. A cover plate (1) arranged to cover a machined opening made in a mounting base for the purpose of using a lock, **characterised in that** the cover plate comprises a groove (5, 8, 9) arranged on the surface of the mounting cover that is intended to be fitted against the mounting base, said groove forming a loop so that it encircles the machined opening when the cover plate (1) is fitted on the mounting base.
2. A cover plate (1) according to Claim 1, **characterised in that** there is a neck of material (7) between the bottom of the groove (5, 8, 9) and the front face of the cover plate.
3. A cover plate (1) according to Claim 2, **characterised in that** the cross-section of the groove (5) is rectangular.
4. A cover plate (1) according to Claim 2, **characterised in that** the cross-section of the groove (8) is triangular and one of the apexes of the triangle forms the bottom of the groove.
5. A cover plate (1) according to Claim 2, **characterised in that** the bottom of the groove (9) is rounded.
6. A cover plate (1) according to any of the Claims from 2 to 5, **characterised in that** the cover plate comprises an inlay part (6) arranged to be fitted into the machined opening in the mounting base.

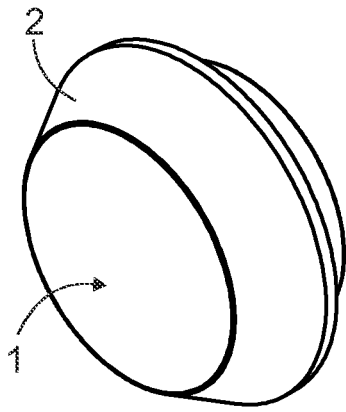

FIG. 1

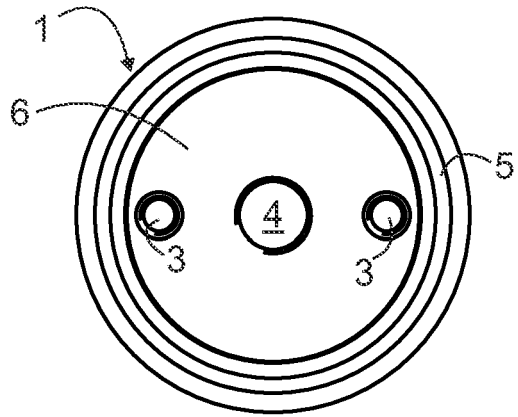

FIG. 2

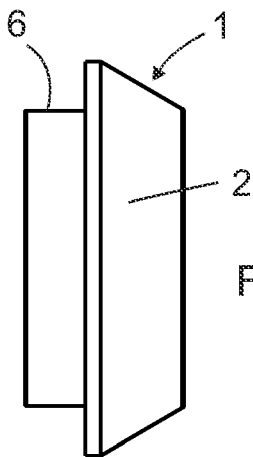

FIG. 3

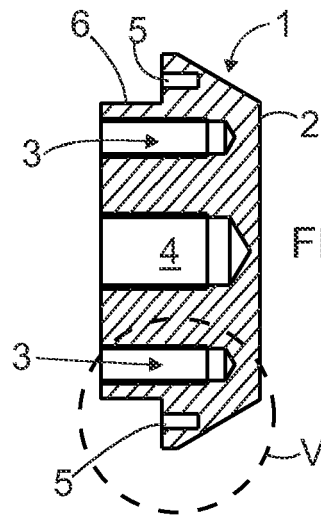

FIG. 4

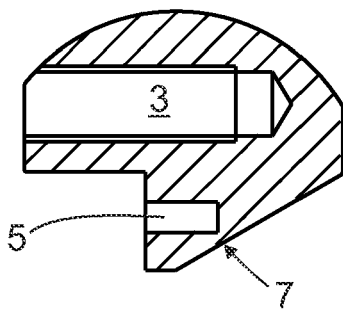

FIG. 5

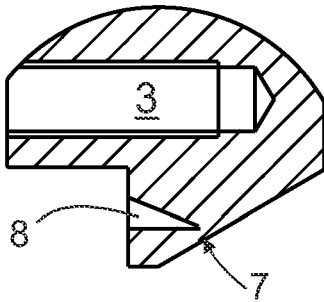

FIG. 6

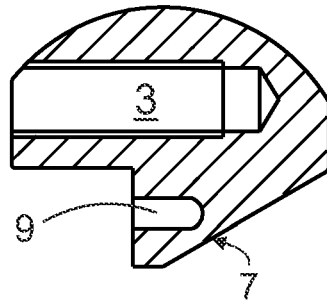

FIG. 7