

[54] **ROTARY HAIR CLIPPER**
 [72] Inventors: **Kenneth D. Deverman**, 333 Old Mill Road; **Charles R. Struck**, 125 Arboleda Road, both of Santa Barbara, Calif. 93110
 [22] Filed: **Nov. 9, 1971**
 [21] Appl. No.: **197,093**
 [52] U.S. Cl. **30/29.5, 30/41.5**
 [51] Int. Cl. **B26b 19/18, B26b 19/44**
 [58] Field of Search **30/29.5, 41.5, 346.51**

2,191,073 2/1940 Fishbein30/29.5

Primary Examiner—Robert O. Riordon
Assistant Examiner—Gary L. Smith
Attorney—Edward R. Lowndes

[57] **ABSTRACT**

A rotary motor driven hair clipper for removing unwanted hair from the nostrils or ears and embodying a tubular shearing head within which a plurality of cooperating orbiting shearing blades function in close-fitting relationship under the influence of centrifugal force. A radial type fan which rotates with the shearing blades creates a suction which draws the sheared hair residue through the tubular shearing head and deposits the same on the inner surface of a removable filter ring.

[56] **References Cited**
UNITED STATES PATENTS
 2,801,465 8/1957 Cason30/29.5
 2,376,197 5/1945 Schlotthauer30/41.5

5 Claims, 10 Drawing Figures

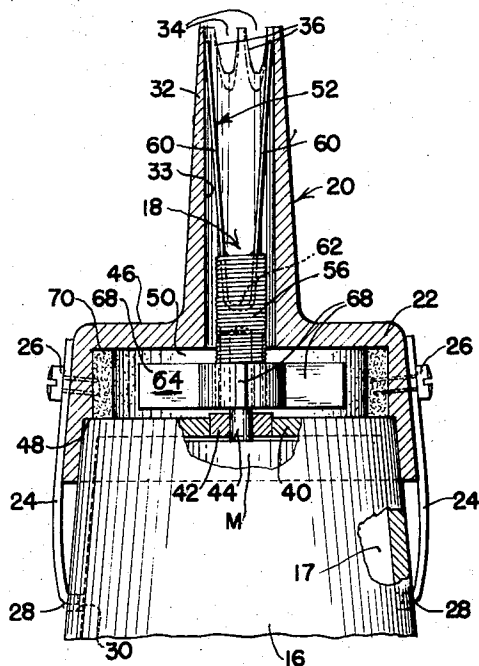

FIG. 1

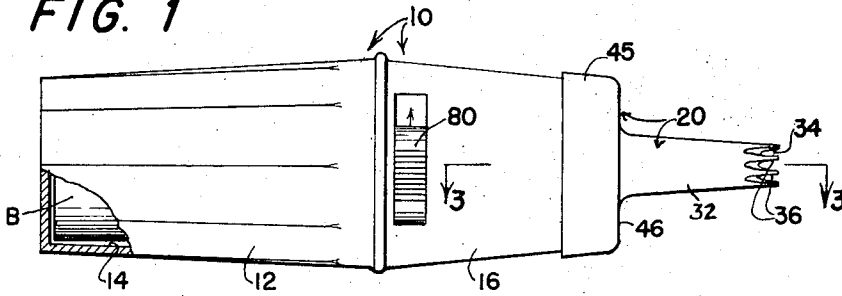

FIG. 2

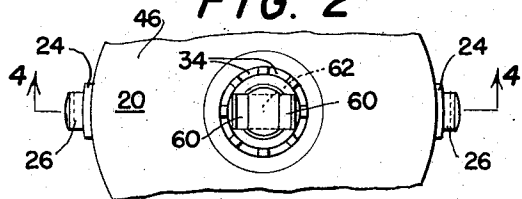

FIG. 3

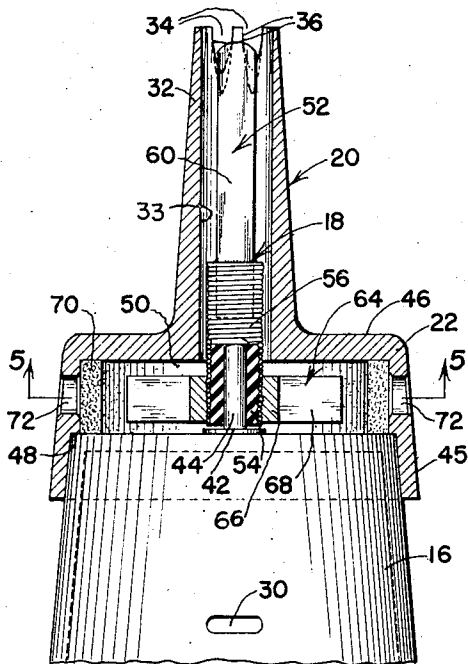

FIG. 4

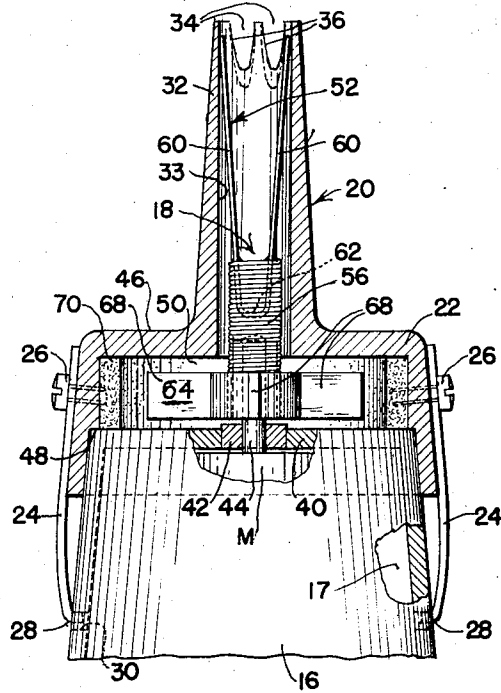
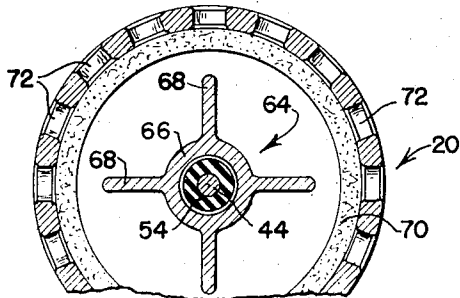

FIG. 5



INVENTOR
KENNETH DEVERMAN

By: Edward R. Lowmiller

FIG. 6

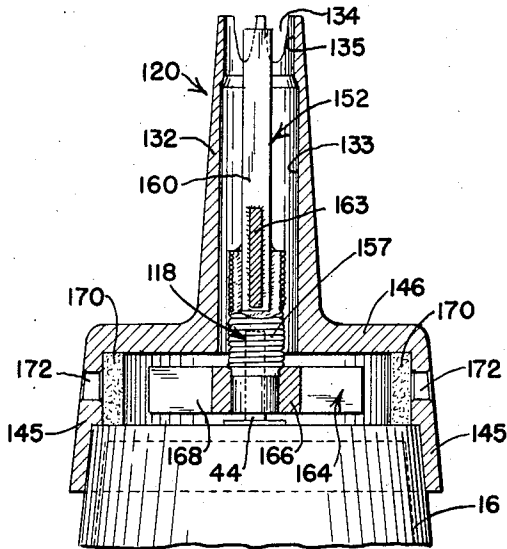

FIG. 7

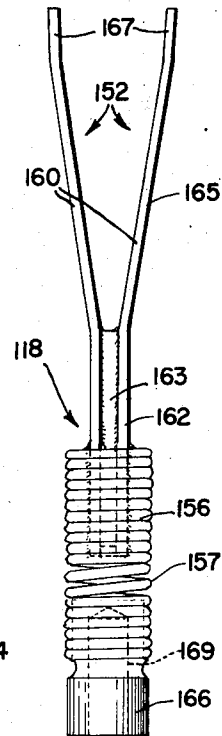

FIG. 10

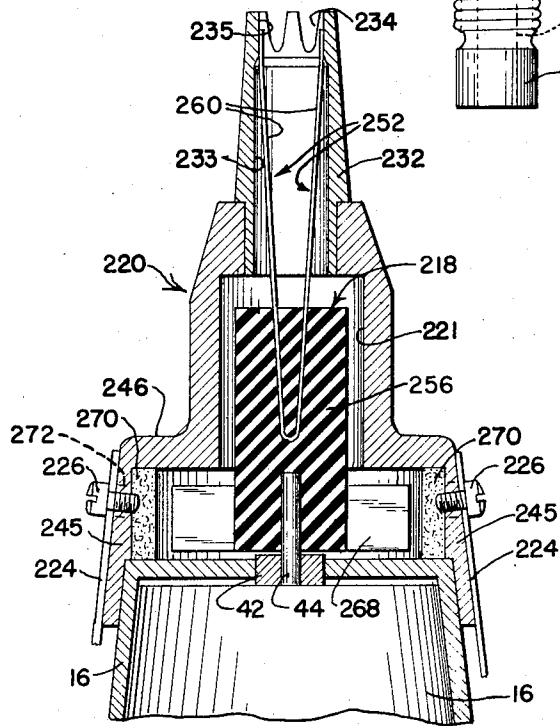

FIG. 8

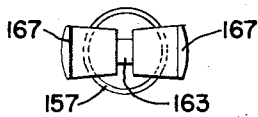
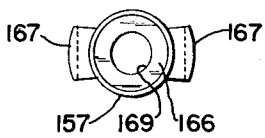

FIG. 9



INVENTOR.
KENNETH DEVERMAN
BY
Edward R. Lowndes

ROTARY HAIR CLIPPER

The present invention relates to tonsorial implements and has particular reference to a novel rotary hair clipper by means of which unwanted hair may conveniently be removed from the nostrils or ears without appreciably distending either of these body orifices. Still more specifically, the invention is concerned with a rotary hair clipper of the general type which employs a tubular shearing head or collet within which a cooperating shearing blade assembly rotates, the diameter of the shearing head being somewhat less than the mean diameter of the body orifice into which the shearing head is inserted for hair clipping or shearing purposes. Cooperating shearing edges on the shearing head and blades effect the desired shearing action during rotation of the shearing blade assembly, such action sometimes being loosely referred to as a unidirectional rotary sickle action as distinguished from the oscillatory straight line sickle action which is present in connection with powered sickle mowers, hedge trimmers and the like.

Present day rotary hair clippers of the type set forth above are possessed of numerous limitations, principal among which is the inability of the cooperating shearing edges to remain sharp. In many such clippers, the rotary blade assembly is a rigid structure which, when the implement is new, serves its purpose in a satisfactory manner but which subsequently becomes worn so that the scissors action of the cooperating blade edges is impaired. Any slight axial misalignment of such a shearing blade assembly is likely to cause blade wobble and concentrate the shearing action on one side of the assembly at the expense of proper shearing action on the other side thereof. Additionally, a rigid coupling between the rotary blade assembly and the motor shaft may lead to binding of the assembly within the shearing head or collet due to clogging of the interfacial space between the tubular head and the internal rigid blade assembly. Another limitation that is attendant upon the construction and use of certain present day rotary hair clippers resides in the fact that they rely for their shearing action upon an inward projection of the individual hairs through side openings or slots in the wall of the tubular shearing head. By such an arrangement unduly long hairs are not always encountered by the shearing edges since they tend to lie flat against the wall of the body orifice and only the shorter upstanding hairs are presented to the shearing edges for clipping purposes. Finally, such few rotary hair clippers as are equipped with suction fan and filter arrangements for drawing the hair clippings through the tubular shearing head employ helical type fan blades which function on the downstream side of a disk-type filter screen. Such helical fan blades lack positive air-impelling action and are subject to the establishment of air churning under load.

The present invention is designed to overcome the above-noted limitations that are attendant upon conventional rotary hair clippers designed for the same purpose as the present clipper and, toward this end, the invention contemplates the provision of a clipper which relies for its clipping action on a novel floating shearing blade assembly embodying elongated flexible finger-like shearing blades which, as the assembly rotates bodily as a unit, are forced radially outwardly by centrifugal force, as well as by spring pressure which is inherent in the flexible blades themselves, into shearing

cooperation with fixed shearing edges which are provided on the surrounding tubular shearing head. The blades themselves are connected in driven relationship to the motor shaft by a flexible coupling which serves automatically to center the blade assembly as a unit axially within the tubular shearing head so that there will be no blade wobble and so that the shearing action will take place uniformly throughout the entire 360° extent of the shearing head. Furthermore, an arrangement of this nature produces a continuous self-sharpening of the shearing edges, both on the blade assembly and shearing head.

The present invention further contemplates the provision of a tubular shearing head in which the shearing edges associated therewith are established by the provision of V-shaped end notches which are provided in the forward rim of the tubular shearing head, the side and bottom edges of such notches establishing sharp shearing edges, and in which the elongated floating flexible cutter blades are provided with sharp shearing edges at their forward distal ends which sweep around the rim region of the tubular shearing head and thus cooperate with such notches for shearing purposes. By such an arrangement a sickle action takes place as the tips of the blades orbit about the central axis of the shearing head so that longitudinal in and out projection of the shearing head, coupled with a slight degree of turning of the head within the nasal cavity will cause the longer hairs which ordinarily lie flat against the skin to enter the V-shaped notches and become clipped by a shearing action similar to that which is involved in connection with the so-called trimming head which are provided on some dry shaver implements.

Insofar as the fan and filter arrangement of the present invention is concerned, the rotary blade assembly includes a series of radial fan blades which operate within a cylindrical hair collection chamber and which is encompassed by a removable cylindrical filter screen, the chamber being in register with the tubular shearing head so that the air-laden air is drawn centrally into the chamber and then flung radially outwardly against the surrounding filter screen. Since the fan is thus on the upstream side of the filter screen and the fan blades are of the radial centrifugal type, as compared to helical fan blades, a more efficient suction is attained.

The provision of a rotary hair clipper which is extremely simple in its construction and which therefore may be manufactured at a relatively low cost; one which is comprised of a minimum number of moving parts and which therefore is unlikely to get out of order; which is rugged and durable and which therefore will withstand rough usage; one which is capable of ease of assembly and disassembly for purposes of inspection or replacement of parts; one which is compact and of lightweight construction; one in which the filter screen is readily removable for cleaning purposes without necessitating the use of tools; one which is smooth and silent in its operation; one which is unlikely to clog or foul; one which is attractive in its appearance and pleasing in its design, and one which otherwise is well adapted to perform the services required of it, are further desirable features which have been borne in mind in the production and development of the present invention.

The construction of a rotary hair clipper such as has briefly been outlined above, and possessing the stated advantages, constitutes the principal object of the present invention. Other objects and advantages of the invention, not at this time enumerated, will readily suggest themselves as the following description ensues.

In the accompanying two sheets of drawings forming a part of this specification, several illustrative embodiments of the invention have been disclosed. In these drawings:

FIG. 1 is a side elevational view of a rotary hair clipper embodying the principles of the present invention;

FIG. 2 is a front end view of the hair clipper of FIG. 1;

FIG. 3 is an enlarged longitudinal sectional view taken substantially on the line 3—3 of FIG. 1;

FIG. 4 is an enlarged sectional view taken substantially on the line 4—4 of FIG. 2;

FIG. 5 is a sectional view taken on line 5—5 of FIG. 3;

FIG. 6 is a fragmentary longitudinal sectional view similar to FIG. 4, showing a modified form of the invention;

FIG. 7 is a side elevational view of the blade assembly of FIG. 6 but showing the blade assembly in its detached or free state;

FIG. 8 is a front end view of the structure shown in FIG. 7;

FIG. 9 is a rear end view of the structure shown in FIG. 7; and

FIG. 10 is a sectional view similar to FIG. 6, showing a further modified form of the invention.

Referring now to the drawings in detail, and in particular to FIGS. 1 to 5 inclusive, the improved hair clipper of the present invention, in one form thereof, involves in its general organization a two-part separable casing 10 which embodies a rear cup-shaped base section 12 adapted to contain a power source such as a dry cell battery B (FIG. 1) and which for this purpose establishes a battery compartment 14. The casing 10 also includes a frusto-conical forward motor section 16 which establishes a motor compartment 17 (FIG. 4) within which there is disposed an electric motor M by means of which a cutter assembly 18, the details of which will be described presently, is powered. A shearing head 20 is provided with a cap portion 22 which is telescopically received over the forward end of the motor section 16 and is removably held in place by a pair of diametrically disposed spring latch fingers 24 (FIGS. 2 and 4) which are anchored by screws 26 to the cap portion 22 and which have in-turned ends 28 which are received in slots 30 provided in the wall of the motor section 16.

Projecting forwardly from the central region of the cap section 22 of the shearing head 20 is an integral tubular collet 32 of frusto-conical configuration and having an appreciable slant height and a small slant angle. A cylindrical bore 33 extends axially through the collet 32. The wall of the collet 32 is tapered forwardly and the forward rim of the same is provided with a series of circumferentially spaced notches 34, the side and bottom edges of which provide a plurality of sharp shearing edges 36 which cooperate with the rotary cutter blade assembly 18 in a manner that will be made clear

subsequently. The extreme forward rim region of the collet 32 thus presents a "castle-like" appearance.

The forward end of the motor section 16 is closed by a front wall 40 within which there is centrally secured a bushing 42 through which the drive shaft 44 of the motor M projects. The tubular collet 32 is integrally formed with the cap section 22 and the base portion of the collet is connected to the skirt portion 45 of the cap section 22 by an annular crown portion or wall 46. The skirt 45 of the cap section 22 is provided with a downwardly facing annular shoulder 48 which seats on the forward circular rim of the motor section 16 when the two latch fingers 24 are in their home positions. The crown portion or wall 46 is thus maintained spaced forwardly from the wall 40, these two walls, in combination with the skirt portion 45, establishing a collection chamber 50 for clipped hair residue.

As best shown in FIGS. 3, 4 and 5, the cutter assembly 18 is comprised of three component parts, namely a spring steel cutter element 52, an elastomeric or other sleeve 54 and a helical coupling spring 56. The sleeve 54 is telescopically received over the motor drive shaft 44 in tight fitting relationship and the coupling spring is similarly telescopically received over the sleeve, thus further compressing the sleeve on the shaft 44. An appreciable length of the spring helix extends above the sleeve 54 and the cutter element 52 has its lower end secured within the confines of the spring 56 above the level of the sleeve so that several of the spring convolutions are free convolutions, which is to say that they are out of contact with either the sleeve 54 or the cutter element 52, these free convolutions establishing a flexible connection between the cutter element and the sleeve. It is to be noted at this point that adjacent spring convolutions are in coextensive contact with each other, which is to say that the helical spring is in its "solid" tightly coiled condition. Thus, in any position of the cutter assembly 18 including its horizontal position when the shearing head 20 is removed from the tool casing 10, the tightly wound spring 56 will support the cutter element 52 in axial alignment with the motor shaft 44 and there will be no tendency for the element to lean in any direction.

The cutter element 52 is comprised of a single length of thin flat spring steel ribbon stock bent to U-shape configuration so as to establish two generally parallel or slightly divergent flat shearing blades proper 60 and an interconnecting bight portion 62 (FIGS. 2 and 3). The bight portion of the cutter element extends into the confines of the helical spring 56 and may be secured therein by means of silver solder or the like, the flow of solder into the spring serving, in effect, to establish a generally tubular sheathe of the solder material around the bight portion 62. If desired, the lower regions of the spring may similarly have silver solder applied thereto but it is essential that the helix convolutions which exist between the cutter element 52 and the bushing 54 shall be free convolutions which are capable of flexing as previously described. The sleeve 54 constitutes a mounting hub for the cutter assembly 18, while the helical spring 56 constitutes a flexible coupling between the cutter element 52 and the hub.

As best seen in FIG. 4, the cutter element 52, when fully received on the motor drive shaft 44, is so disposed that the outer end regions of the shearing

blades proper 60 are in radial shearing register with the shearing edges 36 of the notches 34 in the collet 32. Normally, the tips of the shearing blades 60 lie in close proximity to the wall of the collet 32 or, depending on manufacturing tolerances, are in actual contact with such wall. However, when the implement is in actual use and the cutter assembly is rotating, the blades 60 which are centrifugally balanced by reason of their opposed disposition, are flung apart by centrifugal force so that not only do the extreme tips of the blades ride in circumferential fashion around the inner wall surface of the collet 32, but a short section of each tip may flex so that it is in coextensive contact with the wall of the collet and the shearing edges 36 encounter and cooperate with the leading edge of each blade throughout the entire vertical extent of such shearing edges.

Considering now the manner in which hair residue is drawn through the collet 32 and collected in the chamber 50, the elastomeric sleeve 54 projects downwardly around the motor drive shaft 44 and into this chamber. This projecting portion of the bushing has mounted thereon a centrifugal type fan assembly 64 including a central hub 66 from which there projects radially outwardly a series of fan blades 68. While four such blades are illustrated herein, it is obvious that a greater or a lesser number of such blades may be employed if desired. Encompassing the fan assembly 64 and removably lining the skirt portion 45 of the shearing head 20 is a paper or other filter ring 70 which normally covers a series of air discharge holes 72 which are formed in the skirt portion 45. When the implement is in actual operation, hair residue which is clipped from the nostrils or other body orifice are drawn inwardly through the tubular collet 32 so that they are discharged into the central region of the collection chamber 50 under the influence of the sub-atmospheric pressure which exists within such central region incident to rotation of the fan assembly 64. The air which is flung outwardly by the fan blades 68 establishes a high pressure region in the peripheral regions of the chamber 50 so that air is forced through the filter ring 70 and outwardly through the various holes 72, the hair residue being deposited on the inner surface of the filter ring.

After a period of use, the residue build-up on the filter ring 70 may be removed by lifting the spring latch fingers 24 from the slots 30, removing the shearing head 20 by slipping the same endwise from the shearing blades 60, pulling the filter ring from its seated position within the cap portion 22 of the shearing head 20, washing or otherwise cleaning such filter ring, and re-assembling the hair clipper instrument.

The mounting means for the battery B, the electrical connections by means of which the battery is electrically connected to the motor M, and other features of the present hair clipper which have no direct bearing upon the invention have not been illustrated herein. It will be understood that these features may be varied in accordance with contemplated changes in the design of the clipper. In FIG. 1 a conventional electrical control switch 80 is shown as being mounted on the motor section 16 of the casing 10, the function of the switch being to cause energization and deenergization of the motor M for cutting blade driving purposes.

In FIGS. 6 to 9 inclusive, a modified form of shearing head 120 and cutter assembly 118 are illustrated, these assemblies being capable of substitution on the forward end of the motor section 16 for the previously described shearing head 20 and cutter assembly 18. In view of the similarity between the parts involved in connection with the two forms of the invention, and in order to facilitate comparison of the two structures, similar reference numerals, but of a higher order, have wherever practicable been applied to the corresponding parts as between the disclosures of FIGS. 1 to 5 inclusive and FIGS. 6 to 9 inclusive.

The shearing head 120 remains substantially the same as the shearing head 20 except for the fact that the axial bore 133 in the tubular collet part 132 is provided with a slightly reduced internal diameter at its forward end as indicated at 135 in the vicinity of the notches 134 and the function of which will be made clear presently. Otherwise the shearing head 120 is provided with an annular crown portion 146 from which there depends a skirt portion 145 having air discharge holes 172 therein which cooperate with a filter ring 170 in the manner previously set forth in connection with the filter ring 70 and holes 72.

The cutter blade assembly 118 embodies a cutter element 152 in which the lower regions 162 of the integral blades proper 160 are brought into close proximity and parallelism and are separated by a spacer member 163, while the forward regions are divergent as indicated at 165 so that the cutter element 152 takes on a "Y" appearance. The extreme outer end portions 167 of the divergent portions 165 are preferably but not necessarily turned inwardly at a small angle so that they are less divergent than the regions 165.

The spring 156, instead of being completely solid, is provided with a "stretched" or non-solid section 157 while the forward region of the spring exists in a tightly wound solid state and encompasses the lower portion of the slightly spaced parallel portions 162 of the cutter element 132 and also of the spacer member 163. This solid region of the spring and its adjacent portions of the cutter element and spacer member may be silver soldered or otherwise bonded together.

The rear region of the spring 156 is similarly tightly wound and solid and it encompasses a mounting nipple or hub 166 which is formed of metal and replaces the bushing 66 in the previously described form of the invention. The nipple 166 is provided with a socket 169 therein by means of which the entire cutter assembly 118 may be press fitted onto the forward end of the motor shaft 44. Silver solder may likewise be applied to this lower solid section of the spring 156. The fan assembly 64 may be telescopically received over the mounting nipple 166.

The operation of the form of the invention shown in FIGS. 6 to 9 inclusive is similar to that previously described in connection with the disclosure of FIGS. 1 to 5 inclusive. However, the reduced outer or forward end portion 135 of the collet part 132, coupled with the fact that the distance between the outer end portions 167 of the cutter blades 160 in the free state of the cutter element 152 is greater than the internal diameter of the collet part 132 causes these end portions 167 to yieldingly bear against the collet wall under spring pressure. This spring pressure is augmented by the action of

centrifugal force at such time as the clipper is set into operation. Additionally, the disposition of the outer end portions 165 of the cutter blades 160 insures proper seating of the blades against the wall of the collet part 132 and efficient shearing action between the shearing edges of the blades and collet part. Finally, the intermediate "stretched" portion 157 of the spring 156 affords greater flexibility and assists in a self-centering action of the entire cutter assembly 118 as a whole.

In FIG. 10 a further modified form of shearing head 220, cutter blade assembly 218 and fan are disclosed, these assemblies being capable of substitution for the shearing head 20 and assemblies 18 and 64 on the forward end of the motor section 16. Again, in order to facilitate comparison, similar reference numerals but of a still higher order have been, wherever practicable, applied to the corresponding parts as between the disclosures of FIGS. 4 and 10.

The shearing head 220 is provided with a separately formed collet part 232, the two parts being press fitted together as indicated at 237. A cylindrical bore 233 extends axially through the collet part 232 and is of slightly reduced diameter as shown at 235 near the notches 234 which are formed in the collet part. The shearing head 220 is recessed at 221 to accommodate the reception of a portion of the cutter blade assembly 218 as will be described presently. The skirt portion 245 and crown portion 246 of the head 220 remain substantially the same as the skirt portion 45 and crown portion 46 of the shearing head 20. Also, the fastening screws 226 and latch fingers 244 remain substantially the same as the screws 26 and fingers 44. A filter ring 270 encompasses the fan assembly 264 and functions in the manner of the filter ring 70 to remove hair residue from the discharge air streams which issue from the discharge holes 272 in the skirt portion 245.

The cutter blade assembly 218 includes a cutter element 252 having diverging cutter blades 260 and the base region of the assembly is embedded in a molded plastic member 256 of cylindrical configuration and on the lower end of which a plurality of radial fan blades 268 are formed. The member 256 is press fitted on the forward end of the motor shaft 44.

From the above description it is believed that a detailed explanation of the operation of the present rotary hair clipper in any of its illustrated and described forms, is not necessary for a full understanding of the invention. The operation of each feature of the invention such as the manner in which the cutter blade assemblies 18 or 118, cooperates with the surrounding collet part 32 or 132 to shear hair from the nostrils or other body orifice, and the manner in which the fan assembly 64, 164 or 264 functions to draw hair residue into the collection chamber and deposit the same on the filter ring has been set forth in detail in the foregoing description and does not require repetition.

The invention is not to be limited to the exact arrangement of parts shown in the accompanying drawings or described in this specification since various changes in the details of construction may be resorted to without departing from the spirit of the invention. Therefore, only insofar as the invention has particularly been pointed out in the accompanying claims is the same to be limited.

Having thus described the invention, what I claim and desire to secure by letters patent is:

1. A rotary hair clipper for removing unwanted hair from a nasal cavity, said clipper comprising in combination a casing, a fixed tubular collet projecting forwardly from said casing and designed for endwise insertion into said cavity, said collet presenting a forward open rim having a series of circumferentially spaced generally V-shaped notches formed therein, the side edges of said notches constituting fixed shearing edges, a motor disposed within said casing and having a drive shaft coaxial with said collet, a cutter assembly mounted on said drive shaft for rotation bodily therewith, said cutter assembly including a mounting hub on the drive shaft and a pair of elongated flexible diametrically opposed centrifugally balanced shearing blades projecting forwardly from the hub within the confines of the collet, and a yieldable flexible coupling extending between the cutter blades and hub, said flexible coupling being in the form of a helical spring having its forward region anchored to the rear regions of the cutter blades, and having its rear region anchored to the forward region of the hub, the medial region of said spring serving to maintain the cutter blades and hub in axially spaced relationship, said blades being adapted upon rotation of the hub to be flexed radially outwardly under the influence of centrifugal force to enhance their shearing cooperation with the fixed shearing edges of said notches.

2. A rotary hair clipper as set forth in claim 1, wherein said cutter element is in the form of a strip of spring steel ribbon stock bent transversely to U-shape configuration so as to provide a pair of forwardly extending arms each of which constitutes one of said shearing blades, and an interconnecting bight portion, the rear region of said cutter element including said bight portion projects into the forward end region of said helical spring in tight fitting relationship and is anchored therein, the forward region of the hub projects into the rear end region of the spring in tight fitting relationship and is anchored therein, and a number of adjacent free helix convolutions of the spring are interposed between the cutter element and hub and constitute said flexible coupling.

3. A rotary hair clipper as set forth in claim 2, wherein said free helix convolutions are loosely wound convolutions and said forward and rear end regions of the spring constitute tightly wound convolutions.

4. A rotary hair clipper as set forth in claim 2, wherein said hub is in the form of a tubular sleeve which is telescopically received over said drive shaft and the rear region of said helical spring encompasses the sleeve and serves to compress the same.

5. A rotary hair clipper as set forth in claim 2, wherein said casing is provided with a front wall through which said drive shaft projects, the tubular collet is provided with a cap portion which is removably mounted on the forward end of the casing and which, in combination with said front wall, establishes a hair residue collection chamber in communication with the interior of said collet, said mounting hub is telescopically received over said motor drive shaft, a plurality of generally radially extending fan blades are integrally formed on said mounting hub for rotation within said chamber, the cap portion is provided with a series of air outlet openings, and a filter member is interposed between the fan and said air outlet openings.

* * * * *