

*S. Ashford,*  
*Pattern for Casting:*

*N<sup>o</sup> 44,149.*

*Patented Sep. 13, 1864.*  
*Fig. 1.*

*Fig. 6.*

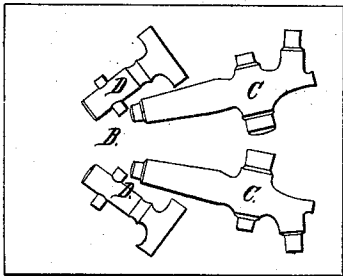

*Fig. 7.*

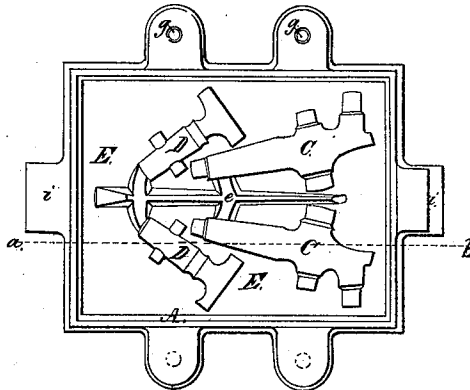
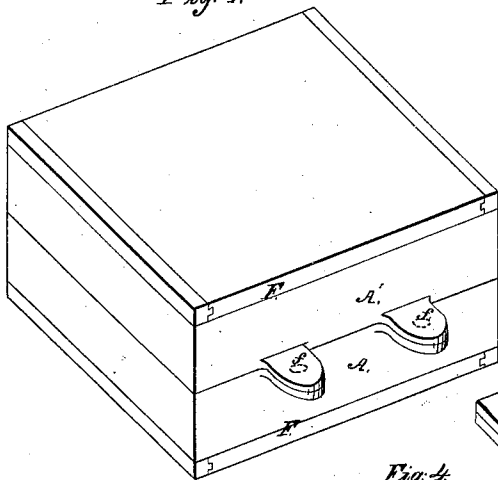

*Fig. 2.*

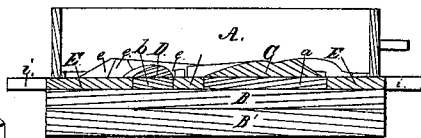

*Fig. 3.*

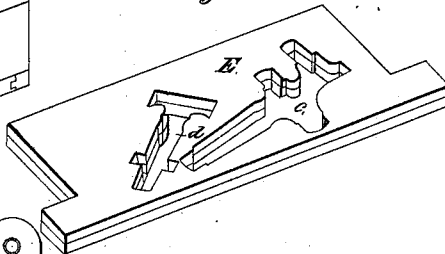

*Fig. 4.*

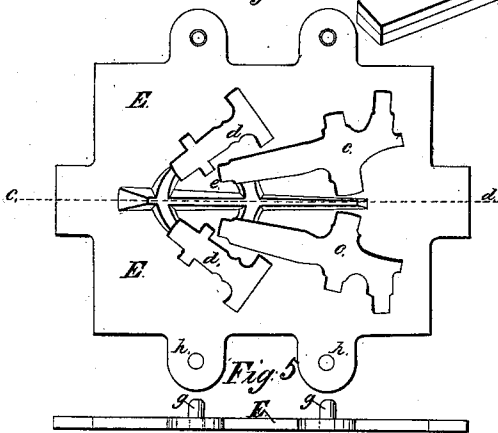

*Witnesses:*  
*L. Zeller*  
*Stephen Ustick*

*Inventor:*  
*Stephen Ashford*

# UNITED STATES PATENT OFFICE.

STEPHEN ASHFORD, OF PHILADELPHIA, PENNSYLVANIA.

## IMPROVED MOLDING APPARATUS.

Specification forming part of Letters Patent No. 44,149, dated September 13, 1864.

*To all whom it may concern:*

Be it known that I, STEPHEN ASHFORD, of the city and county of Philadelphia, and State of Pennsylvania, have invented a new and useful Improvement in Molding Apparatus; and I do hereby declare that the following is a full, clear, and exact description of the construction and operation of the same, reference being had to the annexed drawings, making a part of this specification, in which—

Figure 1 is a top view of the half A of the molding-flask, the relief-plate E, and the patterns C C and D D, which are permanently secured to the card B, on which the relief-plate rests. Fig. 2 is a vertical section of the same at the red line *a b* of Fig. 1, in which is seen, in addition to the parts shown in Fig. 1, pedestals *a* and *b*, the card B, and its base B'. Fig. 3 is a perspective view of the two halves of the relief-plate E, connected with their faces together, and the openings, which will be hereinafter described, formed in them. Fig. 4 is a top view of the said plate, with the middle edges of the two halves permanently secured together at the red line *c d*. Fig. 5 is an edge view of the same. Fig. 6 is a top view of the card B, with the patterns C C and D D attached thereto. Fig. 7 is a perspective view of the two halves A and A' of the flask, and the closing-board F F in connection.

Like letters in all the figures represent the same parts.

The nature of my invention mainly consists in combining and arranging a relief-plate with a molding-flask and card of patterns in such a manner as to produce a perfect mold of all the patterns on the card-plate with only half-patterns on one side thereof, by which means I not only require but one-half the number of pieces that are usually required, but I expedite the operation of molding in a remarkable degree.

To enable others skilled in the art to make and use my invention, I will proceed to describe its construction and operation.

A and A' are two halves of the molding-flask.

B is a card-plate, to which the half-patterns are secured.

C C and D D are half-patterns of a faucet and its key, as represented in Figs. 1, 2, and 6.

B' is a base, to which the card-plate B is firmly screwed, to keep the latter perfectly true. The patterns C C and D D are secured to permanent pedestals *a a* and *b b* on the plate B. The said pedestals are of the same size and shape as the patterns, and consequently are only seen as to their elevation, as in Fig. 2.

E is a relief-plate, which is represented in Figs. 3, 4, and 5, detached from the flask, and in connection therewith in Figs. 1 and 2.

In the said relief-plate there are openings *c c* and *d d* of the same size and shape as the patterns C C and D D, and the pedestals *a a* and *b b*, to which the said patterns are secured, so that when the said plate is laid on the card-plate B the pedestals will fill the openings accurately, and insure a perfect parting of the sand. The relief-plate is made of any suitable thickness, and the height of the pedestals corresponds thereto. I usually make the said plate of metal, and likewise the card-plate B, yet they may be made of wood, if desired. I confine a gate, *e*, on the relief-plate.

F F are closing-boards. Each half of the flask has dowel-pins *f f* at one side, and corresponding holes at the opposite side, so that when the two halves are brought together the dowels of one will fit in the holes of the other; and the relief-plate E has dowels *g g* at one edge, and corresponding holes, *h h*, at its opposite edge, so that each half of the flask when placed on said plate will be held securely in the same way as with its fellow.

The operation is as follows: The relief-plate E is placed in position, as represented in Figs. 1 and 2, with the opening *c c* and *d d* embracing the pedestals *a a* and *b b*, and on a line beneath the patterns C C and D D. The half-flask A is then placed on the plate, as represented in Fig. 1, with the pins *f f* of the flask in the holes *h h* of the plate, by which means the flask is held very steadily in position. The flask is then filled with sand and rammed in the usual manner. It is then removed off of the patterns by taking hold of the handles *i i* of the relief-plate, and turned over on the board F, as represented in Fig. 7. The relief-plate is then again placed in position on the card-plate, and the half-flask A' placed upon it and filled in the same manner as the

first half. The flask is then removed from the patterns in the same manner as the flask A, and taken off of the relief-plate and placed on the first half to complete the mold, as represented in said Fig. 7.

I have represented but two patterns in the drawings, each in separate halves; but it will readily be seen that any desirable number may be placed on the card-plate by having each half in corresponding position on the said plate to the position of its fellow.

My plan for constructing the relief-plate E and arranging the patterns on the card-plate B so as to have them in corresponding positions, to the end that the molds in the two half-flasks will correspond with each other to insure an accurate mold, is as follows: I secure temporarily two plates with their faces together, and form an opening through them of the size and shape of each pattern intended to be placed on the card-plate B, and make the center edge true, so as to form a joint when the edges of the plates are secured to each other, as represented in Fig. 3. I make the plates of equal length also, and then take them apart and secure the center edges together in a permanent manner. The openings in the two plates then correspond to each other as to size, shape, and position. I then place the relief-plate on the card-plate B, and place pedestals for the patterns on the latter plate, and fasten them permanently thereto. I then secure the patterns on their pedestals, and as the openings in one half of the relief-plate correspond to those in the other half, the position of the patterns on one half of the card-plate must correspond also to the position of the other half, and consequently the molds in each half of the flask must likewise correspond; hence a complete and accurate mold is

made, according to the operation, as above explained.

It will readily appear that by the use of the relief-plate E, I lift the molds from the patterns without any possibility of their breaking, and form a more perfect parting than in the old mode of molding, and that consequently the molding is performed in much shorter time, and likewise, that the patterns are secured to the card-plate more accurately and quicker than in the usual mode. Besides, but one-half the number of patterns is required.

Having thus fully described the construction and operation of my improvement in molding apparatus, what I claim therein as new, and desire to secure by Letters Patent, is—

1. Constructing the plate E in halves; and then connecting the halves together, as above described, so as to make the holes in one half thereof, which fit on the pedestals *a b*, correspond with the holes in the other half in shape, size, and position.

2. Constructing the relief-plate E with dowels in one edge and corresponding holes in the other, which correspond in every respect to the arrangement of the dowels and holes in each half of the flask, substantially as represented, so that the latter are thereby separately connected with the relief-plate for the operation of molding, and conjointly with each other to unite the mold by the same means, as above described.

In testimony that the above is my invention I hereunto set my hand and affix my seal this 10th day of June, 1864.

STEPHEN ASHFORD. [L. s.]

Witnesses:

CHAS. E. PANCOAST,  
STEPHEN USTICK.