

Nov. 17, 1953

J. H. BOWMAN

2,659,461

INSULATED METAL WALL PANEL

Filed March 27, 1952

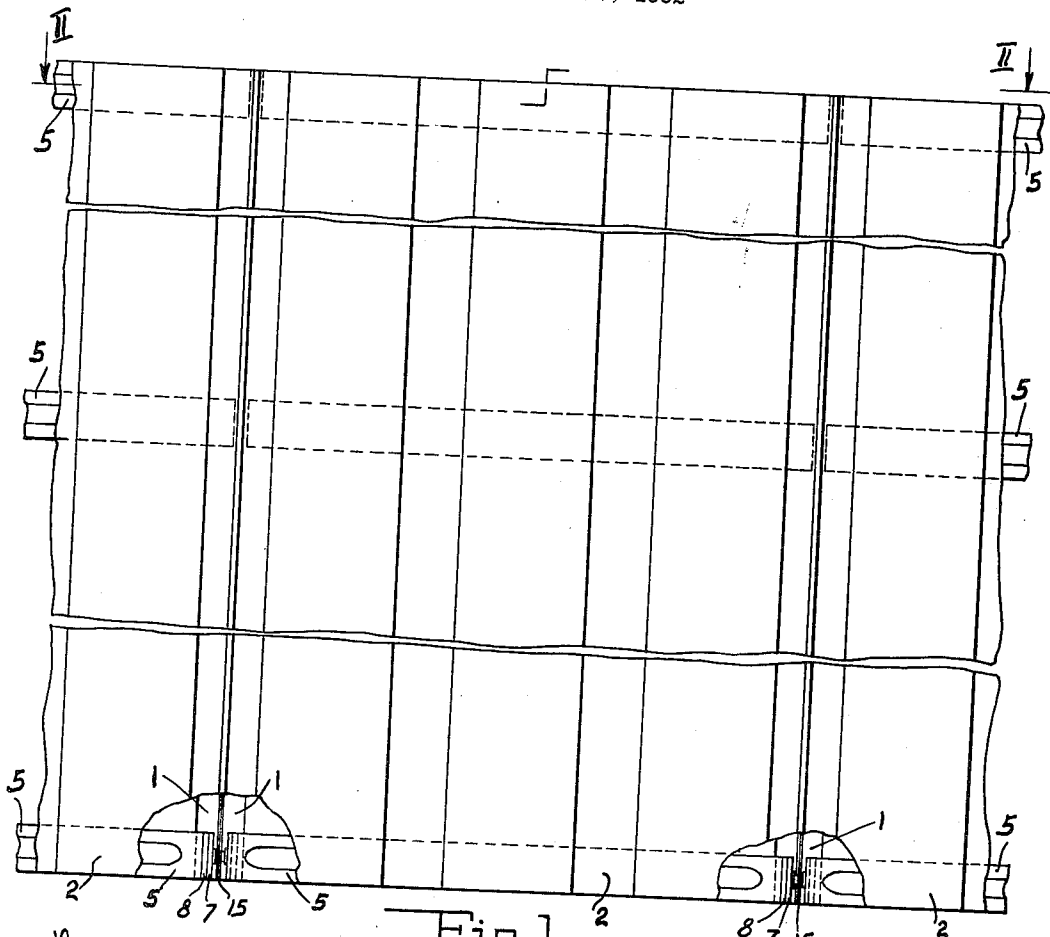

Fig. 1.

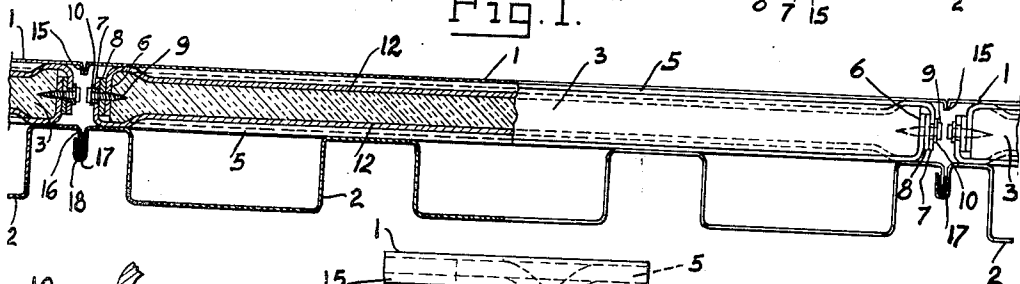

Fig. 2.

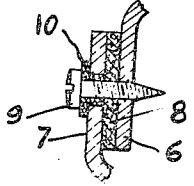

Fig. 4.

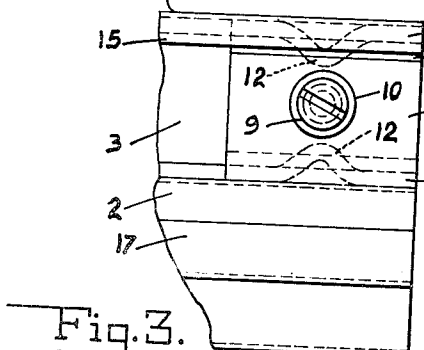

Fig. 3.

INVENTOR.
JOSEPH H. BOWMAN
BY
*Brown, Aitchison, Flick
& Leckham*

UNITED STATES PATENT OFFICE

2,659,461

INSULATED METAL WALL PANEL

Joseph H. Bowman, Pittsburgh, Pa., assignor to
American Steel Band Company, Pittsburgh,
Pa., a corporation of Pennsylvania

Application March 27, 1952, Serial No. 278,889

5 Claims. (Cl. 189—34)

1

This invention relates to metal wall panels, and more particularly to the type in which inner and outer metal sheets are separated by a body of insulation.

Insulated metal wall panels are well known. They generally have a flat surface on one side and a corrugated or fluted surface on the other side. They may be quite tall and have edges which are formed to interlock with one another. The opposite sides of such a panel are spaced apart by a sheet of insulation which may be an inch or more thick. To connect the opposite sides and to give the panel rigidity, it has been customary to fasten the metal sheets to metal members that extend across the width of the panel through the insulation. One of the sheets can be welded to these cross members, before the insulation is applied, but the other one has to be attached by screws because welding can not be done when the space between the metal sheets is filled with insulation. The cross members, being in metal to metal contact with the sheets, conduct heat from one metal sheet to the other. Because of this, it has been found that after these panels are in use a while, the locations of all of the cross members become visible, due to the difference in the rate of heat transfer at the cross members causing a difference in the amount of dirt that adheres to the metal sheets in those places. Light colored streaks extend across the panels wherever the cross members are located.

It is among the objects of this invention to provide an insulated metal wall panel of the general character just described, in which both sides of the panel can be welded to the connecting metal cross members, and in which the rate of heat conduction between the opposite sides of the panel is substantially uniform throughout its area so that the panels will not become streaked where the cross members are located.

In accordance with this invention the panel has a central body of insulation, across the opposite sides of which extend a plurality of parallel metal bars. The ends of the bars are bent part way across the opposite edges of the insulation, and the bars are disposed in pairs having overlapping ends. A thermal insulating member spaces each pair of overlapping ends apart. Each spacing member and the adjoining bar ends are provided with aligned holes, through which extends a screw that is threaded in the inner hole. The screw is also insulated from the bar end containing the outer hole. Consequently, the bars on opposite sides of the sheet are insulated from each other. The metal side sheets of the panel are fastened to the cross bars, preferably by welding before the bars are screwed together.

The preferred embodiment of the invention is illustrated in the accompanying drawings, in which Fig. 1 is a fragmentary side view of

2

a wall formed from my panels; Fig. 2 is an enlarged end view and horizontal section taken on the line II—II of Fig. 1; Fig. 3 is an enlarged fragmentary edge view of a panel lying on its fluted side; and Fig. 4 is an enlarged detail showing the connected ends of cross bars in horizontal section.

Referring to the drawings, each panel is shown with one side formed from a flat metal sheet 1, and the other side formed from a fluted metal sheet 2. However, whether the sheets are flat or fluted is immaterial, but if one sheet is fluted it generally will form the outer wall of the building. These metal sheets are spaced apart to form a space for a thick layer or sheet of suitable insulating material 3, such as fiber glass. The insulation may be an inch or more thick. To connect the two metal sheets together against the opposite sides of the insulation and to make the panel rigid, the metal sheets are fastened to horizontal cross members between them that extend the width of the panel. These cross members are disposed at intervals of several feet throughout the length of the panel.

It is a feature of this invention that instead of there being only a single cross member at each level, which would form a direct path for heat conduction between the side sheets fastened to it, there are two cross members that do not touch each other. One of these is fastened to one of the metal sheets, and the other is secured to the other sheet. Each cross member is a metal bar 5 that has its opposite ends 6 and 7 turned away from the adjoining metal sheet at substantially right angles thereto. The length of these end portions is a little less than the thickness of the insulation between the metal sheets, so that they will not touch the opposite sheet or bar. All of the bars preferably are made the same length and those on the flat sheet are disposed directly opposite to those on the fluted sheet, except that they are offset or staggered lengthwise a short distance to permit the ends of the bars on one side of the insulation to overlap those on the other side with spaces between their adjacent ends. In other words, one end 6 of a bar is spaced from the inner surface of the end 7 of the bar facing it, while the other end of the first bar is spaced from the outer surface of the adjacent end 6 of the second bar. The spaces between the adjacent ends of the bars are filled with thermal insulating members, such as fiber spacers 8. Each spacer and the adjoining bar ends are provided with aligned holes for receiving a screw 9 that connects them rigidly together. A self-tapping screw is used which cuts its own threads in the inner bar end. To avoid direct contact between the screw and the outer bar end 7, the hole in the latter is made oversize and a flanged thermal insulating grommet 10 is placed in the hole around the screw. Consequently,

3

there is no metal to metal contact between the bars.

Each bar 5 is strengthened by providing it with a longitudinal corrugation which forms a rib 12 on its inner surface. This rib also presses into insulation 3 and helps hold the latter in place.

Another desirable feature of this panel arising from the fact that the cross bars 5 are disposed in pairs with each attached to a different metal sheet, is that all of the bars can be welded to the sheets before the panel is assembled with the insulation between the metal sheets. This does away with connecting one of the metal sheets to the cross members by screws after the insulation is in place.

The opposite side edges 15 of the flat metal sheet 1 are bent toward the other sheet 2, preferably at an angle slightly more than ninety degrees so that the edges of these inturned portions on adjoining panels will press tightly against each other when the panels are connected to form a wall. One edge 16 of the fluted sheet is bent straight outward, but the opposite edge is bent outward and then inward to form a hook 17 that loosely receives edge 16 of the adjoining panel. The space inside the hook around edge 16 is filled with caulking compound 18. The hooks hold the panels together, and the caulking compound seals the spaces between them.

According to the provisions of the patent statutes, I have explained the principle of my invention and have illustrated and described what I now consider to represent its best embodiment. However, I desire to have it understood, that within the scope of the appended claims, the invention may be practiced otherwise than as specifically illustrated and described.

I claim:

1. A wall panel comprising an insulating sheet of substantial thickness, a plurality of parallel metal bars extending across the opposite sides of said sheet with their ends bent part way across the opposite edges of the sheet, the bars being disposed in pairs having overlapping ends, a thermal insulating member spacing each pair of overlapping ends apart, each spacing member and the adjoining bar ends being provided with aligned holes, a screw extending inward through said holes and threaded in the inner one, insulating material insulating the portion of the screw in the outer hole from the surrounding metal, whereby the bars on opposite sides of the sheet are insulated from each other, and metal sheets covering the opposite sides of said insulating sheet and fastened to said bars.

2. A wall panel comprising an insulating sheet of substantial thickness, a plurality of parallel metal bars extending across the opposite sides of said sheet with their ends bent part way across the opposite edges of the sheet, the bars being disposed in pairs having overlapping ends, a thermal insulating member spacing each pair of overlapping ends apart, each spacing member and the adjoining bar ends being provided with aligned holes, a screw extending inward through said holes and threaded in the inner one, insulating material insulating the portion of the screw in the outer hole from the surrounding metal, whereby the bars on opposite sides of the sheet are insulated from each other, said bars containing a transverse indentation to provide them with longitudinally extending ribs on their inner surfaces pressing into said insulating sheet, and metal sheets covering the opposite sides of said insulating sheet and fastened to said bars.

4

3. A wall panel comprising an insulating sheet of substantial thickness, a plurality of parallel metal bars extending across the opposite sides of said sheet with their ends bent part way across the opposite edges of the sheet, the bars being disposed in pairs having overlapping ends, a thermal insulating member spacing each pair of overlapping ends apart, each spacing member and the adjoining bar ends being provided with a set of aligned holes, the hole in one end of each bar being smaller than the hole in the other end, all of said bars being substantially the same length with the small hole end of each bar in each pair disposed between the ends of the other bar in the same pair, a screw extending inward through each set of holes and threaded in the inner one, insulating material insulating the portion of the screw in the outer hole from the surrounding metal, whereby the bars on opposite sides of the sheet are insulated from each other, and metal sheets covering the opposite sides of said insulating sheet and fastened to said bars.

4. A wall panel comprising an insulating sheet of substantial thickness, a plurality of parallel metal bars extending across the opposite sides of said sheet with their ends bent part way across the opposite edges of the sheet, the bars being disposed in pairs having overlapping ends, a thermal insulating member spacing each pair of overlapping ends apart, each spacing member and the adjoining bar ends being provided with aligned holes, a screw extending inward through said holes and threaded in the inner one, insulating material insulating the portion of the screw in the outer hole from the surrounding metal, whereby the bars on opposite sides of the sheet are insulated from each other, and metal sheets covering the opposite sides of said insulating sheet and fastened to said bars, one of said metal sheets having its opposite side edges bent toward the other metal sheet at an angle slightly more than ninety degrees.

5. A wall panel comprising an insulating sheet of substantial thickness, a plurality of parallel metal bars extending across the opposite sides of said sheet with their ends bent part way across the opposite edges of the sheet, the bars being disposed in pairs having overlapping ends, a thermal insulating member spacing each pair of overlapping ends apart, each spacing member and the adjoining bar ends being provided with aligned holes, a headed screw extending inward through said holes and threaded in the inner one, a thermal insulating grommet mounted on the screw in the outer hole and provided with a flange spacing the head of the screw from the adjacent bar, whereby the bars on opposite sides of the sheet are insulated from each other, and metal sheets covering the opposite sides of said insulating sheet and fastened to said bars.

JOSEPH H. BOWMAN.

References Cited in the file of this patent

UNITED STATES PATENTS

Number	Name	Date
2,103,407	Dean	Dec. 28, 1937
2,140,709	Mauser	Dec. 20, 1938
2,181,074	Scott	Nov. 21, 1939
2,231,216	Nystrom	Feb. 11, 1941
2,284,229	Palmer	May 26, 1942
2,397,259	Hallicki et al.	Mar. 26, 1946

FOREIGN PATENTS

Number	Country	Date
511,143	Germany	Oct. 27, 1930