

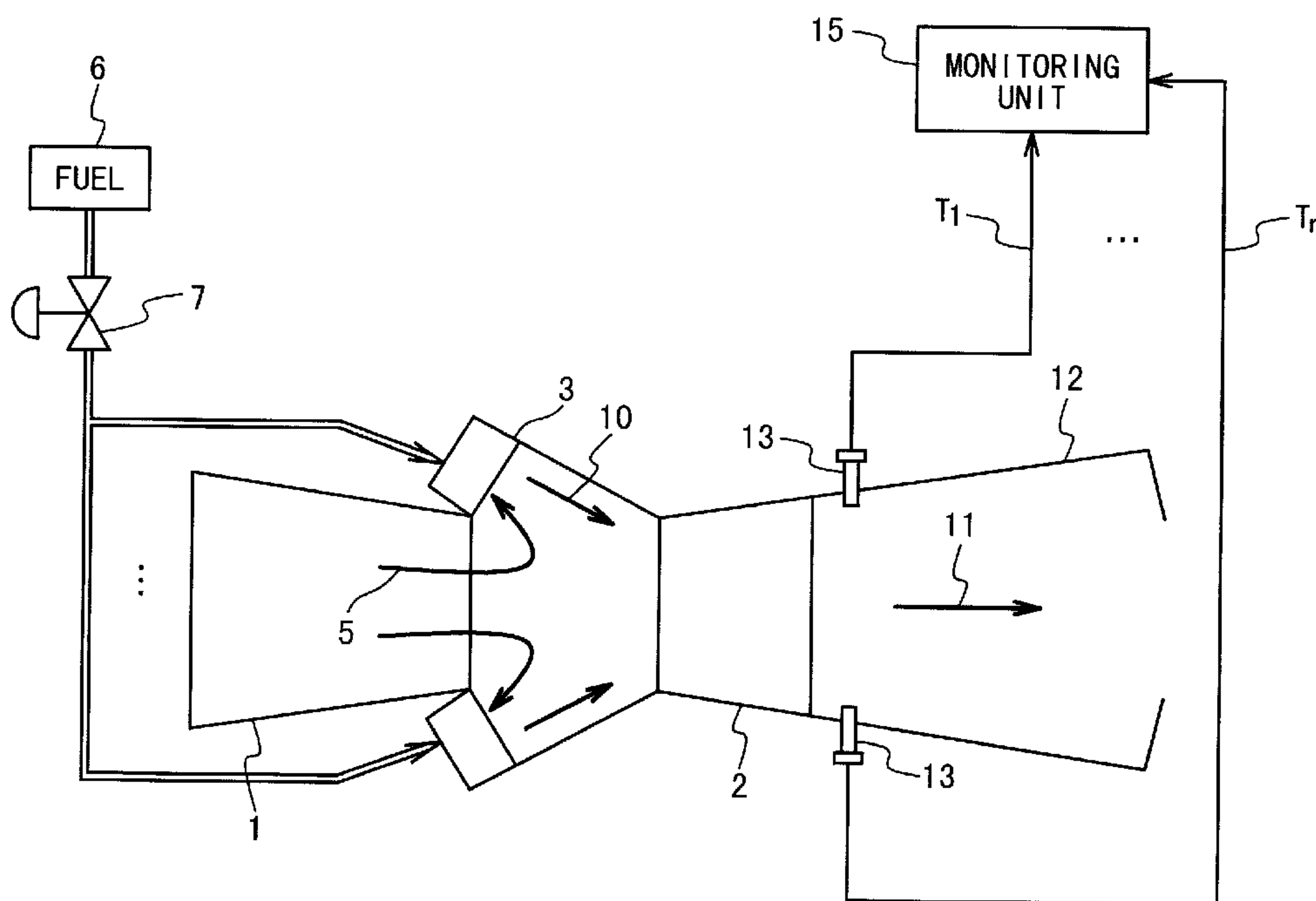

(22) Date de dépôt/Filing Date: 2002/03/13
(41) Mise à la disp. pub./Open to Public Insp.: 2002/10/17
(30) Priorité/Priority: 2001/04/17 (118626/2001) JP

(51) Cl.Int.⁷/Int.Cl.⁷ F02C 7/00
(71) Demandeur/Applicant:
MITSUBISHI HEAVY INDUSTRIES, LTD., JP
(72) Inventeurs/Inventors:
NAGATA, SHOUICHI, JP;
KOMIYAMA, HIROYA, JP
(74) Agent: G. RONALD BELL & ASSOCIATES

(54) Titre : TURBINE A GAZ AVEC DETECTEUR D'ETAT ANORMAL A HAUTE SENSIBILITE
(54) Title: GAS TURBINE PLANT WITH HIGH DETECTION SENSITIVITY OF EXTRAORDINARY STATE



(57) Abrégé/Abstract:

A gas turbine plant includes a combustion section (3), a turbine section (2), an exhaust section (12), a temperature detecting unit (13), and a monitoring unit (15). The combustion section combusts fuel using air to generate combustion gas. The turbine section is driven with the combustion gas from the combustion section. The exhaust section is connected to the turbine section to exhaust the combustion gas from the turbine section. The temperature detecting unit is provided in the exhaust section to measure a temperature of the combustion gas. The monitoring unit generates a warning signal based on a tolerable level and data corresponding to a temporal change of the temperature measured by the temperature detecting unit to indicate an extraordinary state of the gas turbine plant.

Abstract of the Disclosure

A gas turbine plant includes a combustion section (3), a turbine section (2), an exhaust section (12), a temperature detecting unit (13), and a monitoring unit (15). The combustion section combusts fuel using air to generate combustion gas. The turbine section is driven with the combustion gas from the combustion section. The exhaust section is connected to the turbine section to exhaust the combustion gas from the turbine section. The temperature detecting unit is provided in the exhaust section to measure a temperature of the combustion gas. The monitoring unit generates a warning signal based on a tolerable level and data corresponding to a temporal change of the temperature measured by the temperature detecting unit to indicate an extraordinary state of the gas turbine plant.

(Fig. 2)

GAS TURBINE PLANT
WITH HIGH DETECTION SENSITIVITY OF EXTRAORDINARY STATE

Background of the Invention

5 1. Field of the Invention

The present invention relates to a gas turbine plant. Especially, the present invention relates to a gas turbine plant with a monitoring unit to monitor temperature in a turbine outlet and to
10 detect an extraordinary state of the gas turbine plant.

2. Description of the Related Art

Fig. 1 shows an example of a conventional gas turbine plant. The gas turbine plant shown in Fig. 7 is comprised of a compressor 101, a gas turbine
15 section 102, a combustion section 103 and a power generator 104. External air is taken in by the compressor 101, and is compressed, and supplied to the combustion section as compression air 105. Fuel 106 is supplied to the combustion section 103. The
20 combustion section 103 combusts the fuel 106 using the compression air 105 to form the combustion air 110. The combustion air 110 is discharged from an exhaust section 112 as exhaust gas 111 after driving the turbine section 102.

25 N temperature detectors (N is a positive integer) 113 are provided in the exhaust section 112 in the neighborhood of an outlet of the gas turbine

- 2 -

section 102. The N temperature detectors 113 are on N positions of the circumference of the exhaust section 112 in a constant interval. The N temperature detectors 113 monitor and measure the temperatures T_1 to T_n on N positions in the neighborhood of the turbine outlet of the gas turbine section 102, i.e., blade path temperatures. The measured temperatures T_1 to T_n are supplied to a monitoring unit 115. The monitoring unit 115 compares each of the temperatures T_1 to T_n and a predetermined target value. The monitoring unit 115 detects an extraordinary state of the gas turbine plant when the difference of each of the temperatures T_1 to T_n and a predetermined target value is equal to or larger than a tolerable level and emits a warning signal.

However, the temperatures T_1 to T_n in the neighborhood of the turbine outlet change even when the gas turbine plant is operating normally. When the output of the gas turbine plant changes, swirler phenomenon is caused. As a result, the combustion gas 110 outputted from the combustion section 103 passes through the turbine section 102 in a twisted state. When the combustion gas 110 is twisted, the blade path temperatures T_1 to T_n change. Such changes of the blade path temperatures T_1 to T_n are not caused due to the extraordinary state of the combustion section 103.

Therefore, it is not possible to improve a

- 3 -

detection sensitivity of the extraordinary state of the combustion section 103 by decreasing the tolerable level of the difference between each of the temperatures T_1 to T_n and the predetermined target value, if the changes of the blade path temperatures T_1 to T_n are considered.

In conjunction with the above description, a steam monitoring system in a steam cooled type gas turbine is disclosed in Japanese Laid Open Patent Application (JP-P2000-18050A). In this reference, cooling steam is supplied to a cooling object such as a combusting unit and winds. A temperature detector detects an exit temperature of the cooling steam after the cooling. A control apparatus inputs a detection signal from the temperature detector, and compares the detection signal with a predetermined signal. Also, the control apparatus generates a warning signal, a signal for adjusting an opening degree of a fuel flow rate adjusting valve or closing a closing valve, when the detection signal exceeds a predetermined signal.

Summary of the Invention

Therefore, an object of the present invention is to provide a gas turbine plant which monitors blade path temperatures to detect an extraordinary state of a combustion section more correctly.

Another object of the present invention is to

provide a gas turbine plant which has a high detection sensitivity of an extraordinary state of a combustion section, even if the changes of the blade path temperatures are caused.

5 In an aspect of the present invention, a gas turbine plant includes a combustion section, a turbine section, an exhaust section, a temperature detecting unit, and a monitoring unit. The combustion section combusts fuel using air to generate combustion gas.

10 The turbine section is driven with the combustion gas from the combustion section. The exhaust section is connected to the turbine section to exhaust the combustion gas from the turbine section. The

15 temperature detecting unit is provided in the exhaust section to measure a temperature of the combustion gas. The monitoring unit generates a warning signal based on a tolerable level and data corresponding to a temporal change of the temperature measured by the temperature detecting unit to indicate an

20 extraordinary state of the gas turbine plant.

The monitoring unit may include a temperature change determining section which compares the tolerable level and the data corresponding to the temporal change of the measured temperature and

25 generates the warning signal based on the comparison result. In this case, the temperature change determining section may include a delay unit and a

- 5 -

difference calculating unit. The delay unit delays the measured temperature by a predetermined time period to produce a delayed temperature. The difference calculating unit calculates a difference between the delayed temperature and the measured temperature and outputs the calculated difference as the data corresponding to the temporal change of the measured temperature.

Also, when the gas turbine plant include a plurality of the temperature detecting units, the monitoring unit may include an averaging circuit and a plurality of temperature change determining sections. The averaging circuit calculates an average temperature of a plurality of the temperatures measured by the plurality of temperature detecting units. Each of the plurality of temperature change determining sections compares the tolerable level and the data corresponding to the temporal change of a temperature difference between the average temperature and a corresponding one of the plurality of measured temperatures and generates the warning signal based on the comparison result. In this case, the temperature change determining section may include a first difference calculating unit, a delay unit and a second difference calculating unit. The first difference calculating unit calculates the temperature difference between the average temperature and the corresponding

- 6 -

measured temperature. The delay unit delays the temperature difference by a predetermined time period to produce a delayed temperature difference. The second difference calculating unit calculates a difference between the delayed temperature difference and the temperature difference and outputs the calculated difference as the data corresponding to the temporal change of the temperature difference.

Also, the tolerable level may be determined based on data varying in correspondence to an output of the gas turbine plant. In this case, when the gas turbine plant may include a plurality of the temperature detecting units, the monitoring unit may include an averaging circuit which calculates an average temperature of a plurality of the temperatures measured by the plurality of temperature detecting units, and the data varying in correspondence to an output of the gas turbine plant is the average temperature. Instead, the data varying in correspondence to an output of the gas turbine plant may be a quantity of the fuel supplied to the combustion unit. Otherwise, when the gas turbine plant may include a fuel control valve, the data varying in correspondence to an output of the gas turbine plant may be an opening degree of the fuel control valve.

Also, the monitoring unit further may include

a determining unit which compares the measured temperature and a predetermined threshold level and generates another warning signal based on the comparison result.

5 Also, when the gas turbine plant includes a plurality of the temperature detecting units, the monitoring unit further may include an averaging circuit which calculates an average temperature of a plurality of the temperatures measured by the
10 plurality of temperature detecting units; and a plurality of determining units, each of which compares a corresponding one of the measured temperatures and the average temperature and generates another warning signal based on the comparison result.

15 In another aspect of the present invention, a method of operating a gas turbine plant is achieved by (a) combusting fuel using air to generate combustion gas; by (b) driving a turbine with the combustion gas; by (c) exhausting the combustion gas from the turbine;
20 by (d) measuring a temperature of the combustion gas; and by (e) generating a warning signal based on a tolerable level and data corresponding to a temporal change of the temperature measured by the temperature detecting unit to indicate an extraordinary state of
25 the gas turbine plant.

In this case, the (e) generating step may be achieved by (f) comparing the tolerable level and the

- 8 -

data corresponding to the temporal change of the measured temperature to generate the warning signal based on the comparison result. In this case, the (f) comparing steps may include delaying the measured
5 temperature by a predetermined time period to produce a delayed temperature; and calculating a difference between the delayed temperature and the measured temperature to output the calculated difference as the data corresponding to the temporal change of the
10 measured temperature.

Also, the (d) measuring step may be achieved by measuring a plurality of the temperatures of the combustion gas at a plurality of positions, and the (e) generating step may be achieved by calculating an
15 average temperature of a plurality of the measured temperatures; and by (g) comparing the tolerable level and the data corresponding to the temporal change of a temperature difference between the average temperature and a corresponding one of the plurality of measured
20 temperatures to generate the warning signals based on the comparison result. In this case, the (g) comparing step may include calculating the temperature difference between the average temperature and the corresponding measured temperature; delaying the
25 temperature difference by a predetermined time period to produce a delayed temperature difference; and calculating a difference between the delayed

temperature difference and the temperature difference to output the calculated difference as the data corresponding to the temporal change of the temperature difference.

5 Also, the tolerable level may be determined variably based on data corresponding to an output of the gas turbine plant.

Brief Description of the Drawings

10 Fig. 1 is a diagram showing the structure of a conventional gas turbine plant;

Fig. 2 is a diagram showing the structure of a gas turbine plant according to a first embodiment of the present invention;

15 Fig. 3 is a diagram showing the structure of a monitoring unit used in the gas turbine plant in the first embodiment;

Fig. 4 is a diagram showing the structure of a temperature change determining unit of the monitoring unit in the gas turbine plant in the first embodiment;

20

Fig. 5 is a graph showing dependence of a tolerable level R to an absolute value of a temporal change of the output P of the gas turbine plant in the first embodiment;

25

Fig. 6 is a block diagram showing the structure of the monitoring unit used in the gas

- 10 -

turbine plant in a second embodiment; and

Fig. 7 is a block diagram showing the structure of a temperature change determining unit of the monitoring unit in the gas turbine plant in the
5 second embodiment.

Description of the Preferred Embodiments

Hereinafter, a gas turbine plant according to the present invention will be described with reference
10 to the attached drawings.

Fig. 2 is a block diagram showing the structure of the gas turbine plant according to the first embodiment of the present invention. Referring to Fig. 2, the gas turbine plant in the first
15 embodiment is comprised of a compressor 1, a turbine section 2, a combustion section 3, an exhaust section 12, and a monitoring unit 15.

The compressor 1 takes in external air, compresses and supplies the compressed air to the
20 combustion section 3 as compression air 5. Fuel 6 is supplied to the combustion section 3 through a fuel supply valve 7. The combustion section 3 combusts the fuel 6 using the compression air 5 to form combustion air 10. The combustion air 10 is discharged from the
25 exhaust section 12 as exhaust gas 11 after driving the turbine section 2.

The N (N is a positive temperature)

- 11 -

temperature detectors 13 are provided in the exhaust section 12 in the neighborhood of the turbine outlet of the turbine section 2. The N temperature detectors 13 are provided on N positions of a circumference of the exhaust section in a constant interval. However, only two of the temperature detectors 13 are illustrated in Fig. 2. The N temperature detectors 13 monitor and measure the temperatures of the combustion gas on the N positions in the neighborhood of the turbine outlet. The measured temperatures are referred to as blade path temperatures T_1 to T_n . The temperature detectors 13 output the blade path temperatures T_1 to T_n to the monitoring unit 15. The monitoring unit 15 detects an extraordinary state of the gas turbine plant from the blade path temperatures T_1 to T_n and outputs warning signals.

Fig. 3 shows the structure of the monitoring unit 15. The monitoring unit 15 contains an average calculating unit 21, comparing and determining unit 22-1 to 22-n, temperature change determining units 23-1 to 23-n and OR gates 24-1 to 24-n.

The average calculating unit 21 calculates an average temperature T_{AVE} of the blade path temperatures T_1 to T_n . The comparing and determining unit 22-1 outputs a warning signal AT-1 when the difference ΔT_1 of the average temperature T_{AVE} and the blade path temperature T_1 is equal to or larger than a

- 12 -

predetermined temperature difference ΔT_{LIM} . On the other hand, the comparing and determining unit 22-1 does not output the warning signal AT-1 when the difference ΔT_1 is smaller than the temperature difference ΔT_{LIM} . The comparing and determining units 22-2 to 22-n operate in the same way as the comparing and determining unit 22-1 except that the blade path temperatures inputted thereto are different. That is, the comparing and determining unit 22-i (i is an integer satisfying a relation of $1 \leq i \leq n$) of the comparing and determining unit 22-1 to 22-n outputs the warning signal AT-i, when the difference ΔT_1 of the average temperature T_{AVE} and the blade path temperature T_1 is equal to or larger than the predetermined temperature difference ΔT_{LIM} . Also, the comparing and determining unit 22-i does not output the warning signal AT-i when the difference ΔT_1 is smaller than the temperature difference ΔT_{LIM} .

The temperature change determining unit 23-1 determines whether the temporal change of the difference ΔT_1 of the average temperature T_{AVE} and the blade path temperature T_1 is equal to or larger than a threshold value. When determining that the temporal change of the difference ΔT_1 is equal to or larger than the threshold value, the temperature change determining unit 23-1 outputs the warning signal ADT-1. When determining that the temporal change of the

- 13 -

difference ΔT_i is smaller than the threshold value, the temperature change determining unit 23-1 does not output the warning signal ADT-1. The temperature change determining units 23-2 to 23-n operate in the same way as the temperature change determining unit 23-1 except that the blade path temperatures inputted thereto are different. That is, the temperature change determining unit 23-i (i is an integer satisfying a relation of $1 \leq i \leq n$) of the temperature change determining units 23-1 to 23-n determines whether the temporal change of the difference ΔT_i of the average temperature T_{AVE} and the blade path temperature T_i is equal to or larger than a corresponding threshold value. When determining that the temporal change of the difference ΔT_i is equal to or larger than the corresponding threshold value, the temperature change determining unit 23-i outputs the warning signal ADT-i. When determining that the temporal change of the difference ΔT_i is smaller than the corresponding threshold value, the temperature change determining unit 23-i does not output the warning signal ADT-i.

The reason why the difference ΔT_i of the average temperature T_{AVE} and the blade path temperature T_i is used for the determination of the extraordinary state is as follows. The blade path temperature T_i changes in accordance with the operation of the gas

- 14 -

turbine plant. Therefore, a reference value used to determine whether or not the gas turbine plant is in an extraordinary state needs to be determined in accordance with the operation situation of the gas turbine plant. In the first embodiment, the average temperature T_{AVE} of the blade path temperatures T_1 to T_n is used as the reference value to determine the extraordinary state of the gas turbine plant. It is possible to determine that the blade path temperature T_1 is extraordinary when the difference ΔT_1 of the average temperature T_{AVE} and the blade path temperature T_1 is equal to or larger than a predetermined value. By using the average temperature T_{AVE} as the reference value to determine the extraordinary state of the gas turbine plant, it becomes unnecessary to determine the reference value to the blade path temperature T_1 in accordance with the operation situation of the gas turbine plant.

Moreover, a tolerable level R to the temporal change of the temperature difference ΔT_1 is changed in accordance with the temporal change of the output P of the gas turbine plant. The reason is as follows. When the output P of the gas turbine plant changes, swirler phenomenon occurs. As a result, the combustion gas outputted from the combustion section 3 passes through the turbine section 2 in a twisted state. When the combustion gas is twisted, the blade path

- 15 -

temperatures T_1 to T_n change. That is, the changes of the blade path temperatures T_1 to T_n caused in accordance with the change of the output P of the gas turbine plant is not an indication of the

5 extraordinary state of combustion section 3.

Therefore, when the output P of the gas turbine plant is changing, the tolerable level R to the temporal change of the temperature difference ΔT_1 is made larger. On the other hand, when the output P of the

10 gas turbine plant is not changing, the tolerable level R to the temporal change of the temperature difference ΔT_1 is made smaller. With this, the extraordinary state of the combustion section 3 can be detected more correctly. The structure and operation of the

15 temperature change determining units 23-1 to 23-n will be described later.

The warning signal $AT-1$ generated by the comparing and determining unit 22-1 and the warning signal $ADT-1$ generated by the temperature change

20 determining unit 23-1 are supplied to the OR gate 24-1. The OR gate 24-1 calculates the logical summation of the warning signal $AT-1$ and the warning signal $ADT-1$ and generates the warning signal $AL-1$. The warning signal $AL-1$ is outputted when the blade path

25 temperature T_1 itself or the temporal change of the blade path temperature T_1 is extraordinary.

In the same way, the warning signal $AT-i$

- 16 -

generated by the comparing and determining unit 22-*i* of the comparing and determining units 22-1 to 22-*n* and the warning signal ADT-*i* generated by the temperature change determining unit 23-*i* of the temperature change determining units 23-1 to 23-*n* are supplied to the OR gate 24-*i*. The symbol *i* is an integer equal to or more than 1 and equal to or smaller than *n*.

In the same way, the OR gate 24-*i* of the OR gates 24-1 to 24-*n* calculates the logical summation of the warning signal AT-*i* and the warning signal ADT-*i* and generates the warning signal AL-*i*. The warning signal AL-*i* is outputted when the blade path temperature T_i itself or the temporal change of the blade path temperature T_i is extraordinary. The warning signals AL-1 to AL-*n* show whether or not the blade path temperatures T_1 to T_n are in the extraordinary states, respectively.

Subsequently, the details of the structure of the temperature change determining units 23-1 to 23-*n* will be described. The temperature change determining units 23-1 to 23-*n* has the same structure except that the blade path temperatures are different. Therefore, the structures of the temperature change determining units will be described using the temperature change determining unit 23-1 as a typical example.

Fig. 4 shows the structure of the temperature

- 17 -

change determining unit 23-1. The temperature change determining unit 23-1 is comprised of a difference unit 31, a delay unit 32, a difference unit 33, an absolute value calculating unit 34, a determining unit 5 35, a delay unit 36, a difference unit 37, an absolute value calculating unit 38, a function unit 39, an AND gate 40, and a delay unit 41.

The difference unit 31 calculates the difference ΔT_1 of the blade path temperature T_1 and 10 the average temperature T_{AVE} . The delay unit 32 delays the temperature difference ΔT_1 by one minute and outputs the delayed temperature difference ΔT_1 . The delayed temperature difference ΔT_1 is hereinafter referred to as a temperature difference $\Delta T_1'$. The 15 temperature difference $\Delta T_1'$ shows the difference before one minute between the blade path temperature T_1 and the average temperature T_{AVE} . The difference unit 33 calculates the difference $\Delta_t T_1$ of the temperature difference ΔT_1 directly received from the 20 difference unit 31 and the delayed temperature difference $\Delta T_1'$. The difference $\Delta_t T_1$ shows the temporal change of the temperature difference ΔT_1 for one minute. The absolute value calculating unit 34 calculates the absolute value $|\Delta_t T_1|$ of the time 25 difference $\Delta_t T_1$. The determining unit 35 determines whether or not the absolute value $|\Delta_t T_1|$ is larger than the tolerable level R . As mentioned above, the

tolerable level R is set based on the temporal change of the output P of the gas turbine plant. The tolerable level R is set by the delay unit 36, the difference unit 37, the absolute value calculating unit 38 and the function unit 39.

The output P of the gas turbine plant is supplied to the delay unit 36. The delay unit 36 delays the output P by one minute and outputs the delayed output P . The delayed output P is hereinafter referred to as an output P' . The output P' is the output of the gas turbine plant one minute before. The difference unit 37 calculates the temporal change $\Delta_t P$ of the output P . The temporal change $\Delta_t P$ shows the temporal change of the output P of the gas turbine plant for one minute. The absolute value calculating unit 38 calculates the absolute value $|\Delta_t P|$ of the temporal change $\Delta_t P$. The function unit 39 calculates the above-mentioned tolerable level R based on the absolute value $|\Delta_t P|$.

Fig. 5 shows the dependence of the tolerable level R on the absolute value $|\Delta_t P|$ calculated by the function unit 39. An example of the setting is shown below. The tolerable level R increases sense in accordance with the absolute value $|\Delta_t P|$ monotonously in a wide. In detail, the tolerable level R takes a constant of β_1 in case of $0 \leq |\Delta_t P| \leq \alpha_1$. Also, in case of $\alpha_1 \leq |\Delta_t P| \leq \alpha_2$, the tolerable level R increases from

- 19 -

β_1 to β_2 in accordance with the increase of $|\Delta_t P|$ linearly. Also, in case of $|\Delta_t P| \geq \alpha_2$, the tolerable level R takes a constant value of β_2 . That is, when the temporal change of the output P of the gas turbine plant is large, the tolerable level R becomes large, and when the temporal change of the output P of the gas turbine plant is small, the tolerable level R becomes small. However, the minimum of the tolerable level R is β_1 and the upper limit of the tolerable level R is β_2 .

The output of the determining unit 35 becomes an ON state when the absolute value $|\Delta_t T_1|$ is equal to or more than the tolerable level R, and becomes an OFF state when the absolute value $|\Delta_t T_1|$ is smaller than the tolerable level R. The output of the determining unit 35 is connected with the first input terminal of the AND gate 40.

A parallel signal ON is supplied to the delay unit 41 to show whether or not the gas turbine plant is in the operation state. The parallel signal ON is set to the ON state when the gas turbine plant is in the operation state. The output terminal of the delay unit 41 is connected with the second input terminal of the AND gate 40. The delay unit 41 delays the parallel signal ON by one minute, and outputs the delayed parallel signal ON.

The AND gate 40 calculates a logical product

- 20 -

of the output of the determining unit 35 and the output of the delay unit 41, and outputs the above-mentioned warning signal ADT-1. The warning signal ADT-1 is set to the ON state when the gas turbine
5 plant is in the operation state, and the absolute value $|\Delta_t T_1|$ is equal to or higher than the tolerable level R. The extraordinary state of the temporal change of the blade path temperature T_1 is warned by the warning signal ADT-1.

10 As mentioned above, the temperature change determining units 23-1 to 23-n have the same structure except that the blade path temperatures are different, and the explanation is not carried out.

In the first embodiment, the extraordinary
15 state of the blade path temperature detects T_i based on the temporal change $|\Delta_t T_i|$ of the temperature difference ΔT_i of the blade path temperature T_i and the average temperature T_{AVE} . Thus, even if the change of the blade path temperature T_i is detected when the
20 combustion section 3 is not in an extraordinary state, it is not determined as the extraordinary state of the combustion section 3. In this way, the detection sensitivity of the extraordinary state of the combustion section 3 can be made high.

25 Moreover, in the blade path temperature monitoring unit in the first embodiment, the tolerable level R to the temporal changes $|\Delta_t T_1|$ to $|\Delta_t T_n|$ of

- 21 -

the temperature differences ΔT_1 to ΔT_n is adjusted based on the temporal change of the output P of the gas turbine plant. With this, even if the change of the blade path temperature T_1 is caused because of the occurrence of swirler phenomenon accompanying the operation of the gas turbine plant when the combustion section 3 is not in the extraordinary state, the detection sensitivity of the extraordinary state of the combustion section 3 can be made higher.

It should be noted that in the first embodiment, the tolerable level R to the temporal changes $|\Delta_t T_1|$ to $|\Delta_t T_n|$ of the differences ΔT_1 to ΔT_n is set based on the output P of the gas turbine plant. However, the tolerable level R may be set based on other physical quantities having one-to-one correspondence to the output P of the gas turbine plant. For example, as the output P of the gas turbine plant increases, the average temperature T_{AVE} of the above-mentioned blade path temperatures T_1 to T_n becomes higher, and has one-to-one correspondence to the output P of the gas turbine plant. Therefore, an average T_{AVE} can be used, instead of the output P of the gas turbine plant.

Also, as the output P of the gas turbine plant increases, the temperature of the gas exhausted from the turbine section 2 becomes higher and one-to-one correspondence to the output P of the

- 22 -

gas turbine plant. Therefore, the temperature of discharge gas 11 may be used, instead of the output P of the gas turbine plant.

Also, the output P of the gas turbine plant becomes large as the flow rate of the fuel 6 supplied to the combustion section 3 increases. Therefore, the flow rate of the fuel 6 has one-to-one correspondence to the output P of the gas turbine plant. Thus, the flow rate of the fuel 6 supplied to the combustion section 3 can be used instead of the output P of the gas turbine plant.

Moreover, the output P of the gas turbine plant becomes larger as the opening degree of the fuel supply valve 7 for supplying the fuel 6 to the combustion section 3 becomes larger. Therefore, the opening degree of the fuel supply valve 7 has one-to-one correspondence to the output P of the gas turbine plant. Thus, the opening degree of the fuel supply valve 7 can be used instead of the output P of the gas turbine plant.

The gas turbine plant in the second embodiment has the almost same structure as the gas turbine plant in the first embodiment. In the gas turbine plant in the second embodiment, a monitoring unit 15' is used in place of the monitoring unit 15 of the gas turbine plant in the first embodiment. The other parts of the gas turbine plant in the second

- 23 -

embodiment has same as those in the first embodiment and carries out the same operations.

Fig. 6 shows the structure of the monitoring unit 15' of the gas turbine plant in the second embodiment. Referring to Fig. 6, the monitoring unit 15' is different from the monitoring unit 15 of the gas turbine plant in the first embodiment in the point that the monitoring unit 15' does not calculate the average T_{AVE} of the blade path temperatures T_1 to T_n . As shown in Fig. 6, the monitoring unit 15' is comprised of comparing and determining units 22-1' to 22-n', temperature change determining units 23-1' to 22-n' and OR gates 24-1 to 24-n.

The comparing and determining unit 22-1' outputs the warning signal AT-1 when the difference δT_1 of the blade path temperature T_1 and a predetermined reference value is equal to or larger than a predetermined temperature difference δT_{LIM} . The comparing and determining unit 22-1' does not output the warning signal AT-1 when the difference δT_1 is smaller than the temperature difference δT_{LIM} .

The comparing and determining units 22-2' to 22-n' operate in the same way as the comparing and determining unit 22-1 except that the blade path temperatures inputted thereto are different. That is, the comparing and determining unit 22-i' (i is an integer equal to or more than 1 or equal to or less

- 24 -

than n) of the comparing and determining units 22-1 to 22-n. When the difference δT_1 of the blade path temperature T_1 and the predetermined reference value is equal to or larger than the predetermined

5 temperature difference δT_{LIM} , the comparing and determining unit 22-i' outputs the warning signal AT-i. Also, the comparing and determining unit 22-i' does not output the warning signal AT-i when the difference δT_1 is smaller than the temperature difference δT_{LIM} .

10 The temperature change determining unit 23-1' determines whether or not the temporal change of the blade path temperature T_1 is extraordinary. It should be noted that in the first embodiment, the extraordinary state is detected based on the temporal

15 change of the difference ΔT_1 of the average temperature T_{AVE} and the blade path temperature T_1 in the temperature change determining unit 23-1 of the monitoring unit 15. In the second embodiment, the temperature change determining unit 23-1' outputs the

20 warning signal ADT-1, when determining that the temporal change of the blade path temperature T_1 is extraordinary. The temperature change determining unit 23-1' does not output the warning signal ADT-1, when determining that the temporal change of the blade

25 path temperature T_1 is not extraordinary.

The temperature change determining units 23-2' to 23-n' operate in the same ways as the

- 25 -

temperature change determining unit 23-1' except that the blade path temperatures supplied thereto are different. That is, the temperature change determining unit 23-i' (i is an integer equal to or more than 1 and equal to or less than n) of the temperature change determining units 23-1 to 23-n determines whether or not the temporal change of the blade path temperature T_i is extraordinary. The temperature change determining unit 23-i outputs the warning signal ADT-i, when determining that the temporal change of the blade path temperature T_i is extraordinary. The temperature change determining unit 23-i does not output the warning signal ADT-i, when determining that the temporal change of the blade path temperature T_i is not extraordinary. At this time, the tolerable level R to the temporal change of the blade path temperature T_i is changed in accordance with the temporal change of the output P of the gas turbine plant. The reason is as described in the first embodiment.

The OR gate 24-1 calculates the logical summation of the warning signal AT-1 and the warning signal ADT-1 and generates the warning signal AL-1. The warning signal AL-1 is outputted when the temporal change of the blade path temperature T_1 itself or the blade path temperature T_1 is extraordinary.

In the same way, the OR gate 24-i of the OR

gates 24-1 to 24-n calculates the logical summation of the warning signal AT-i and the warning signal ADT-i and generates the warning signal AL-i. The warning signal AL-i is outputted when the blade path
5 temperature T_1 itself or the temporal change of the blade path temperature T_1 is extraordinary. The warning signals AL-1 to AL-n show whether or not the blade path temperatures T_1 to T_n are extraordinary, respectively.

10 Fig. 7 shows the structure of the temperature change determining unit 23-1'. The temperature change determining unit 23-1' has the structure that the difference unit 31 of the temperature change determining unit 23-1 in the first embodiment is
15 removed and the blade path temperature T_1 is directly supplied to the delay unit 32 and the difference unit 33. The temperature change determining unit 23-1' is comprised of a delay unit 32, a difference unit 33, an absolute value calculating unit 34, a determining unit
20 35, a delay unit 36, a difference unit 37, an absolute value calculating unit 38, a function unit 39, an AND gate 40 and a delay unit 41.

The delay unit 32 delays the blade path temperature T_1 by one minute and outputs the delayed
25 blade path temperature T_1 . The delayed blade path temperature T_1 is hereinafter referred to as a delayed blade path temperature T_1' . The difference unit 33

- 27 -

calculates the difference $\Delta_t T_1'$ of the blade path
temperature T_1 directly received and the delayed blade
path temperature T_1' . The difference $\Delta_t T_1'$ shows the
temporal change the blade path temperature T_1 for one
5 minute. The absolute value calculating unit 34
calculates the absolute value $|\Delta_t T_1'|$ of the
difference $\Delta_t T_1'$. The determining unit 35 determines
whether or not the absolute value $|\Delta_t T_1'|$ is
extraordinary, i.e., is equal to or larger than the
10 tolerable level R . The tolerable level R is set based
on the temporal change of the output P of the gas
turbine plant. The tolerable level R is set by the
delay unit 36, the difference unit 37, the absolute
value calculating unit 38 and the function unit 39.

15 The output P of the gas turbine plant is
supplied to the delay unit 36. The delay unit 36
outputs the delayed output P by one minute. The
delayed output P is hereinafter referred to as a
delayed output P' . The output P' is the output of the
20 gas turbine plant one minute before. The difference
unit 37 calculates the difference $\Delta_t P$ of the output P
and the output P' . The difference $\Delta_t P$ shows the
change of the output P of the gas turbine plant for
one minute. The absolute value calculating unit 38
25 calculates the absolute value $|\Delta_t P|$ of the difference
 $\Delta_t P$. The function unit 39 calculates the above-
mentioned tolerable level R based on the absolute

value $|\Delta_t P|$.

An example in which the function unit 39 calculates the tolerable level R based on the absolute value $|\Delta_t P|$ is as described with reference to Fig. 5 in the first embodiment. When the change of the output P of the gas turbine plant is large, the tolerable level R becomes large, and when the change of the output P of the gas turbine plant is small, the tolerable level R becomes small. However, the minimum of the tolerable level R is β_1 and the upper limit of the tolerable level R is β_2 .

The output of the determining unit 35 is set to the ON state when the absolute value $|\Delta_t T_1|$ is equal to or larger than the tolerable level R, i.e., when the combustion section 3 is in an extraordinary state. Also, the output of the determining unit 35 is set to the OFF state, when the absolute value $|\Delta_t T_1|$ is smaller than the tolerable level R, i.e., when the combustion section 3 is not in an extraordinary state. The output of determining unit 35 is connected with the first input terminal of the AND gate 40.

The output terminal of the delay unit 41 is connected with the second input terminal of the AND gate 40. The parallel signal ON shows whether or not the gas turbine plant is in the operation state and is supplied to the delay unit 41. The parallel signal ON is set to the ON state when the gas turbine plant is

- 29 -

in the operation state. The delay unit 41 delayed the parallel signal ON by one minute and outputs the delayed parallel signal ON.

The AND gate 40 calculates the logical product of the output of the determining unit 35 and the output of the delay unit 41 and outputs the above-mentioned warning signal ADT-1. The warning signal ADT-1 is set to the ON state when the gas turbine plant is in the operation state and the absolute value $|\Delta_t T_1|$ is equal to or larger than the tolerable level R. The warning signal ADT-1 warns the extraordinary state of the temporal change of the blade path temperature T_1 .

The temperature change determining units 23-2' to 23-n' have the same structure as the temperature change determining unit 23-1' except that the blade path temperatures inputted thereto are different, and the explanation is not carried out.

The gas turbine plant in the second embodiment detects the extraordinary state of the blade path temperature T_1 based on the temporal change $|\Delta_t T_1|$ of the blade path temperature T_1 . Even if the temporal change of the blade path temperature T_1 is caused when the combustion section 3 is not in an extraordinary state, the detection sensitivity of the extraordinary state of the combustion section 3 can be made high.

- 30 -

Moreover, in the blade path temperature monitor in this embodiment, the tolerable level R to the temporal change $|\Delta_t T_1|$ of the blade path temperature T_1 is adjusted based on the temporal change of the output P of the gas turbine plant. Even if the change of the blade path temperature T_1 is caused due to the occurrence of swirler phenomenon accompanying the operation of the gas turbine plant when the combustion section 3 is not in an extraordinary state, the detection sensitivity of the extraordinary state of the combustion section 3 can be made higher.

It should be noted that in the second embodiment, like the first embodiment, the tolerable level R can be set based on other physical quantities having one-to-one correspondence to the output P of the gas turbine plant. As the other physical quantities, the flow rate of the fuel 6, the temperature of the exhausted gas 11, the opening degree of the fuel supply valve 7 can be used.

According to the present invention, there can be provided with the gas turbine plant in which the blade path temperature is monitored and measured and the extraordinary state of the combustion section is detected. Also, the gas turbine plant has the high sensitivity of the detection of the extraordinary occurrence even if the change of the blade path

- 31 -

temperature is caused when there is no extraordinary state.

What is claimed is:

1. A gas turbine plant comprising:

a combustion section which combusts fuel
using air to generate combustion gas;

a turbine section driven with said combustion
5 gas from said combustion section;

an exhaust section connected to said turbine
section to exhaust said combustion gas from said
turbine section;

a temperature detecting unit provided in said
10 exhaust section to measure a temperature of said
combustion gas; and

a monitoring unit which generates a warning
signal based on a tolerable level and data
corresponding to a temporal change of said temperature
15 measured by said temperature detecting unit to
indicate an extraordinary state of the gas turbine
plant.

2. The gas turbine plant according to claim 1,
wherein said monitoring unit comprises:

a temperature change determining section
which compares said tolerable level and said data
5 corresponding to said temporal change of said measured
temperature and generates said warning signal based on
the comparison result.

- 33 -

3. The gas turbine plant according to claim 2, wherein said temperature change determining section comprises:

a delay unit which delays said measured
5 temperature by a predetermined time period to produce a delayed temperature; and

a difference calculating unit which
calculates a difference between said delayed
temperature and said measured temperature and outputs
10 the calculated difference as said data corresponding to said temporal change of said measured temperature.

4. The gas turbine plant according to claim 1, wherein said gas turbine plant comprises:

a plurality of said temperature detecting
units,

5 said monitoring unit comprises:

an averaging circuit which calculates an
average temperature of a plurality of said
temperatures measured by said plurality of temperature
detecting units; and

10 a plurality of temperature change determining sections, each of which compares said tolerable level and said data corresponding to said temporal change of a temperature difference between said average
temperature and a corresponding one of said plurality
15 of measured temperatures and generates said warning

signal based on the comparison result.

5. The gas turbine plant according to claim 4, wherein said temperature change determining section comprises:

a first difference calculating unit which
5 calculates said temperature difference between said average temperature and said corresponding measured temperature;

a delay unit which delays said temperature difference by a predetermined time period to produce a
10 delayed temperature difference; and

a second difference calculating unit which calculates a difference between said delayed temperature difference and said temperature difference and outputs the calculated difference as said data
15 corresponding to said temporal change of said temperature difference.

6. The gas turbine plant according to claim 1, wherein said tolerable level is determined based on data varying in correspondence to an output of said gas turbine plant.

7. The gas turbine plant according to claim 6, wherein said gas turbine plant comprises:

a plurality of said temperature detecting

units,

5 said monitoring unit comprises:

 an averaging circuit which calculates an
average temperature of a plurality of said
temperatures measured by said plurality of temperature
detecting units, and

10 said data varying in correspondence to an
output of said gas turbine plant is said average
temperature.

8. The gas turbine plant according to claim 6,
wherein said data varying in correspondence to an
output of said gas turbine plant is a quantity of the
fuel supplied to the combustion unit.

9. The gas turbine plant according to claim 6,
further comprising a fuel control valve, and
 wherein said data varying in correspondence
to an output of said gas turbine plant is an opening
5 degree of said fuel control valve.

10. The gas turbine plant according to claim 1,
wherein said monitoring unit further comprises:
 a determining unit which compares said
measured temperature and a predetermined threshold
5 level and generates another warning signal based on
the comparison result.

11. The gas turbine plant according to claim 1,
wherein said gas turbine plant comprises:

a plurality of said temperature detecting
units,

5 said monitoring unit further comprises:

an averaging circuit which calculates an
average temperature of a plurality of said
temperatures measured by said plurality of temperature
detecting units; and

10 a plurality of determining units, each of
which compares a corresponding one of said measured
temperatures and said average temperature and
generates another warning signal based on the
comparison result.

12. A method of operating a gas turbine plant
comprising the steps of:

(a) combusting fuel using air to generate
combustion gas;

5 (b) driving a turbine with said combustion
gas;

(c) exhausting said combustion gas from said
turbine;

(d) measuring a temperature of said
10 combustion gas; and

(e) generating a warning signal based on a
tolerable level and data corresponding to a temporal

change of said temperature measured by said
temperature detecting unit to indicate an
15 extraordinary state of the gas turbine plant.

13. The method according to claim 12, wherein
said (e) generating step comprises the step:

(f) comparing said tolerable level and said
data corresponding to said temporal change of said
5 measured temperature to generate said warning signal
based on the comparison result.

14. The method according to claim 13, wherein
said (f) comparing steps comprises the steps of:

delaying said measured temperature by a
predetermined time period to produce a delayed
5 temperature; and

calculating a difference between said delayed
temperature and said measured temperature to output
the calculated difference as said data corresponding
to said temporal change of said measured temperature.

15. The method according to claim 12, wherein
said (d) measuring step comprises the steps of:

measuring a plurality of said temperatures of
said combustion gas at a plurality of positions, and
5 said (e) generating step comprises the steps
of:

- 38 -

calculating an average temperature of a plurality of said measured temperatures; and

(g) comparing said tolerable level and said data corresponding to said temporal change of a temperature difference between said average temperature and a corresponding one of said plurality of measured temperatures to generate said warning signals based on the comparison result.

16. The method according to claim 15, wherein said (g) comparing step comprises the steps of:

calculating said temperature difference between said average temperature and said corresponding measured temperature;

delaying said temperature difference by a predetermined time period to produce a delayed temperature difference; and

calculating a difference between said delayed temperature difference and said temperature difference to output the calculated difference as said data corresponding to said temporal change of said temperature difference.

17. The method according to claim 12, wherein said tolerable level is determined variably based on data corresponding to an output of said gas turbine plant.

Fig. 1 PRIOR ART

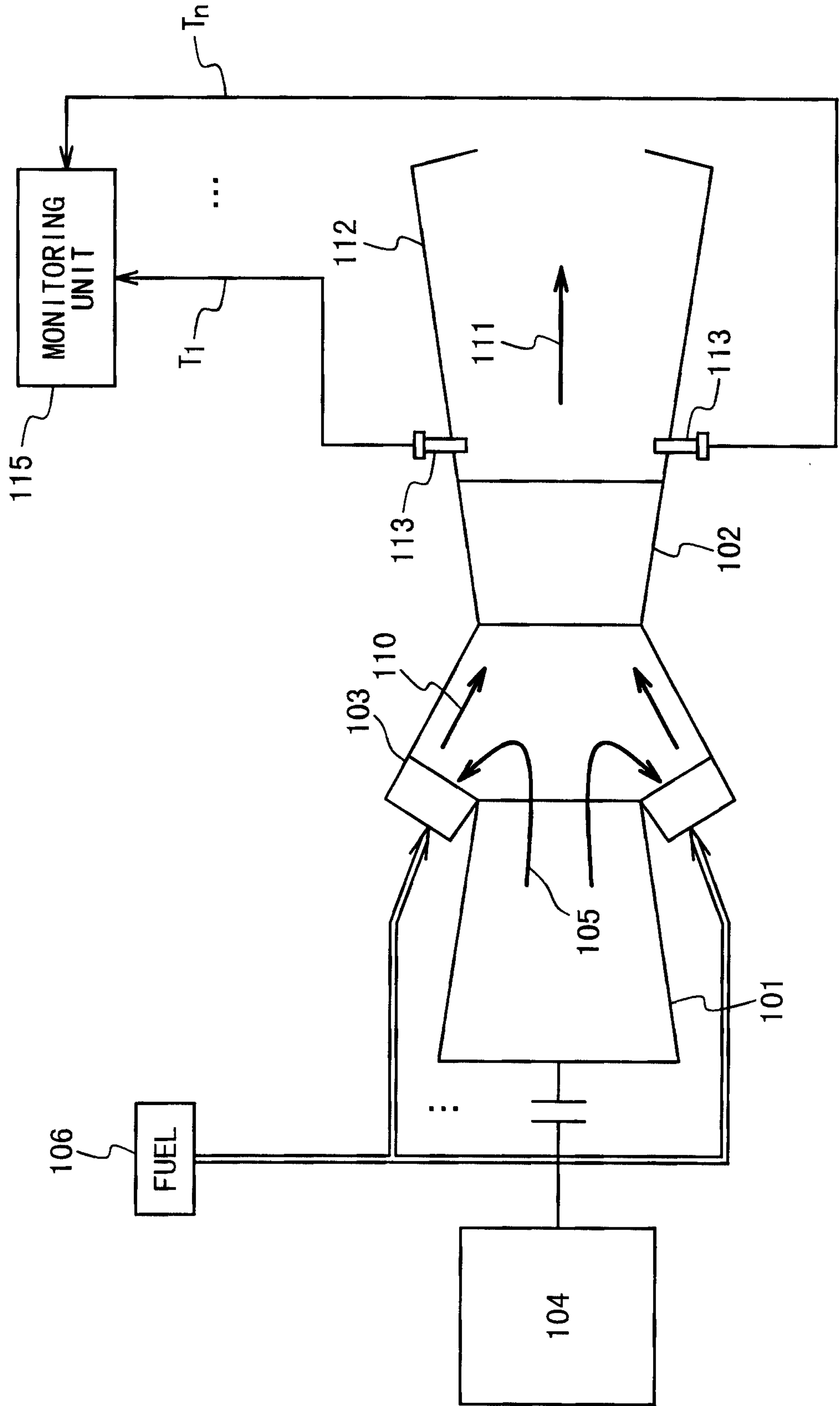

Fig. 2

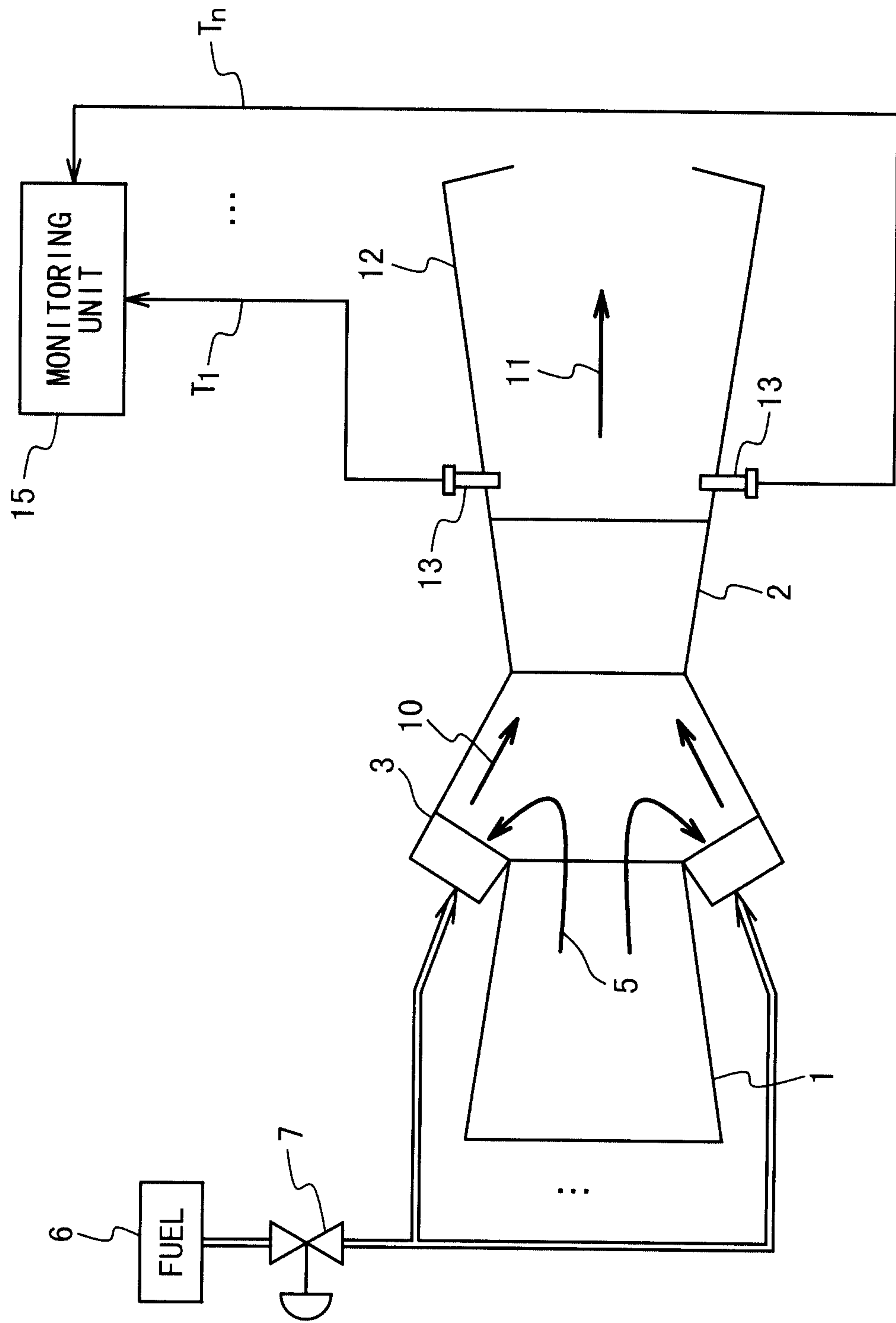

Fig. 3

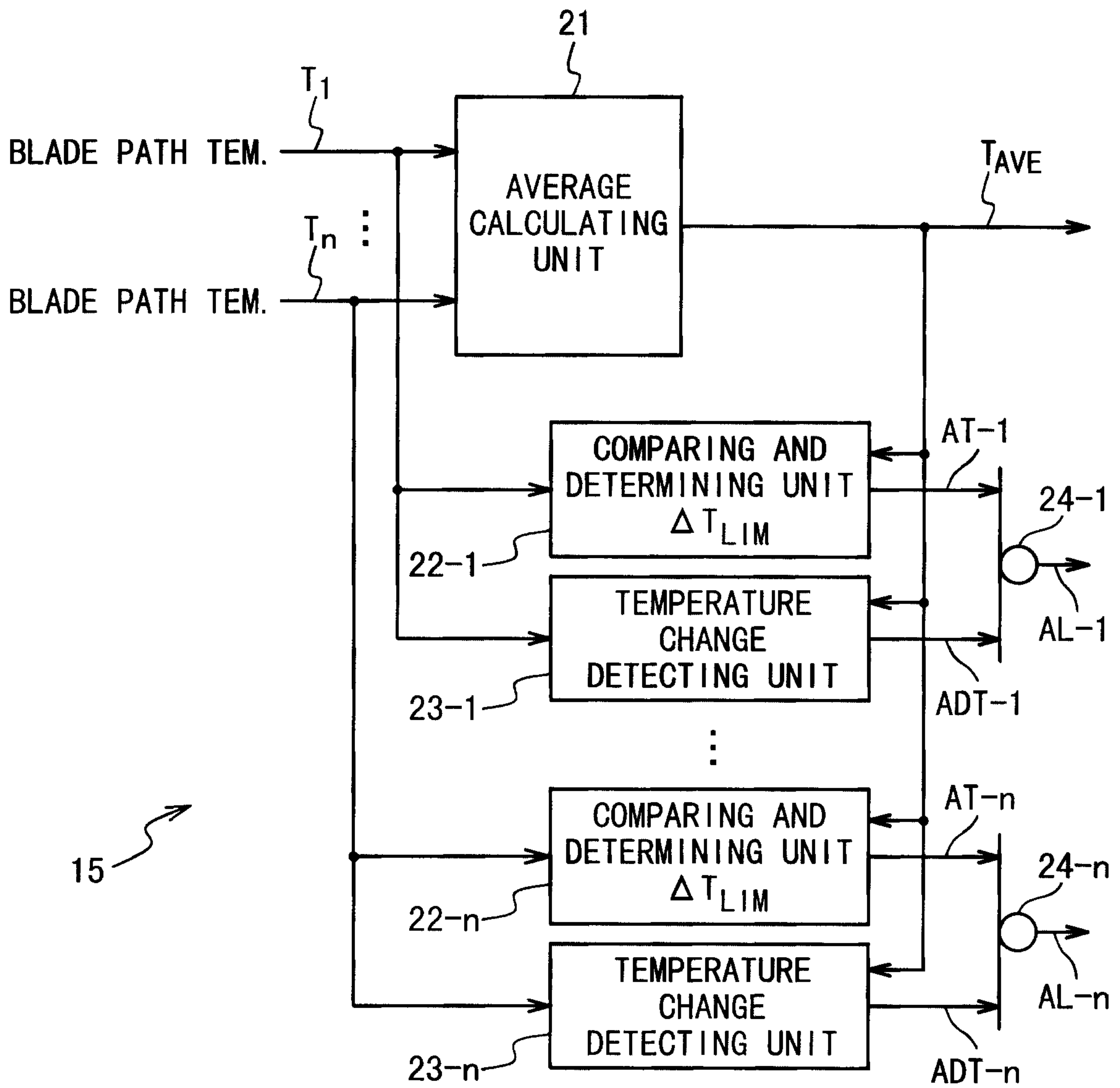

Fig. 4

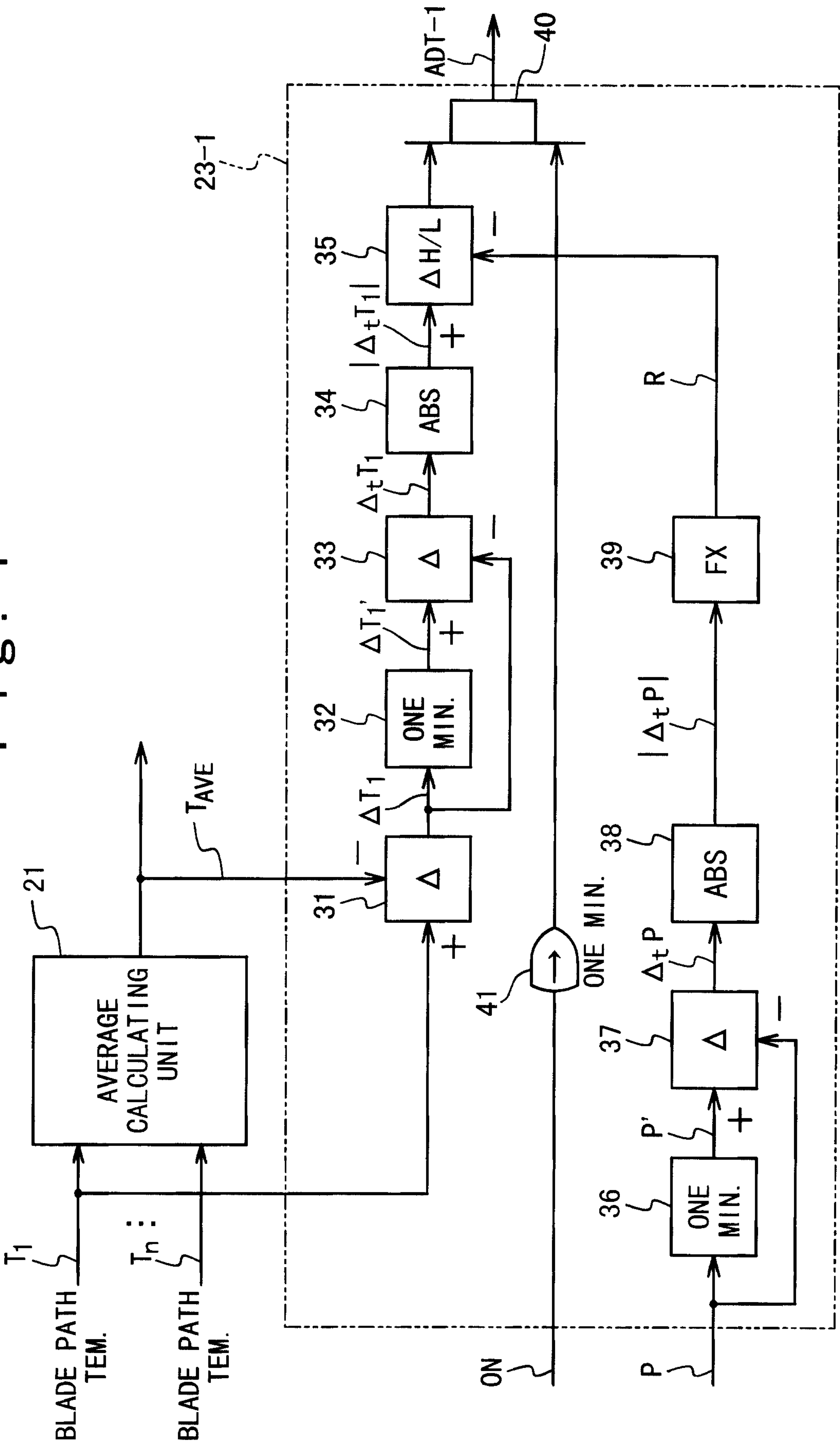

Fig. 5

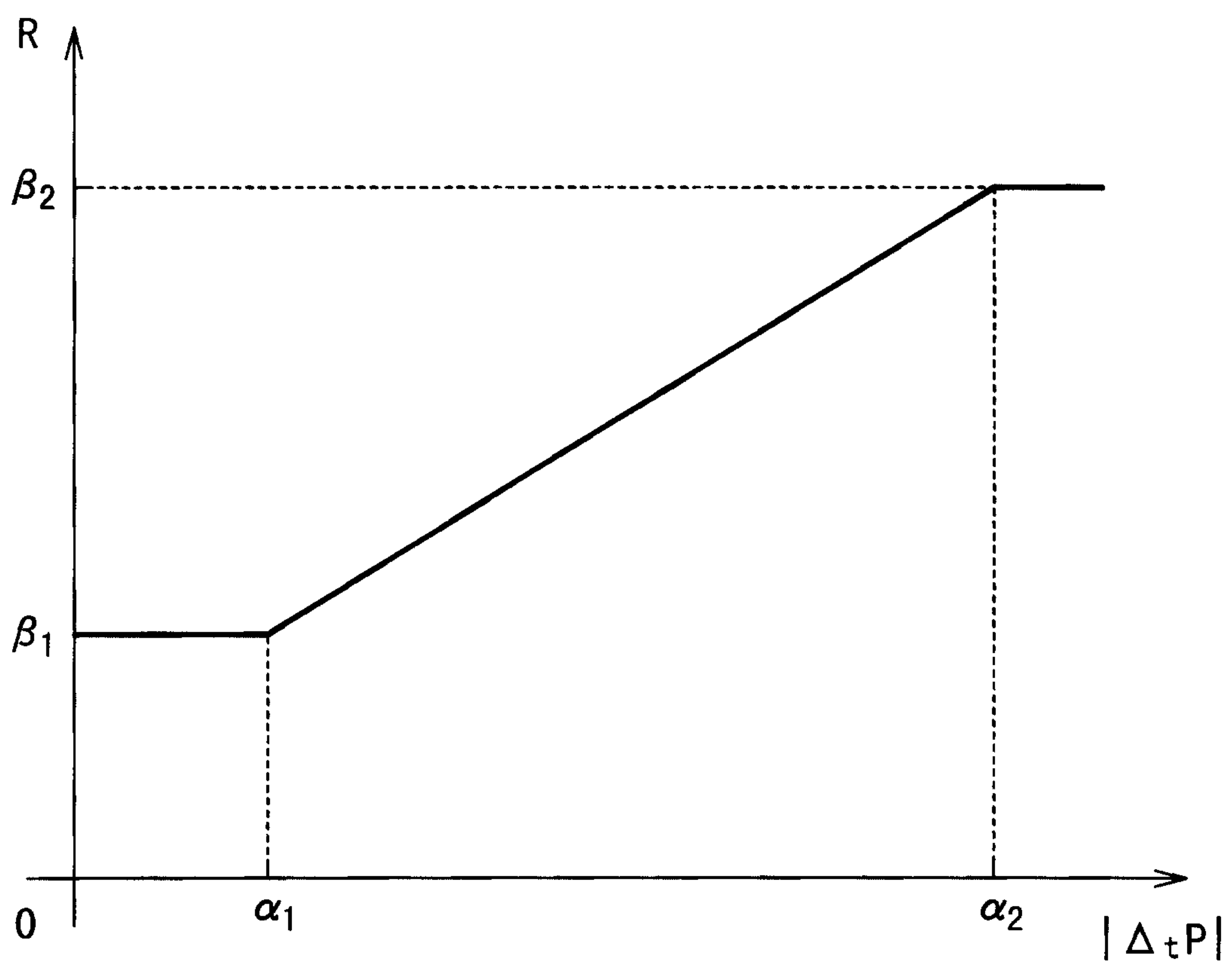

Fig. 6

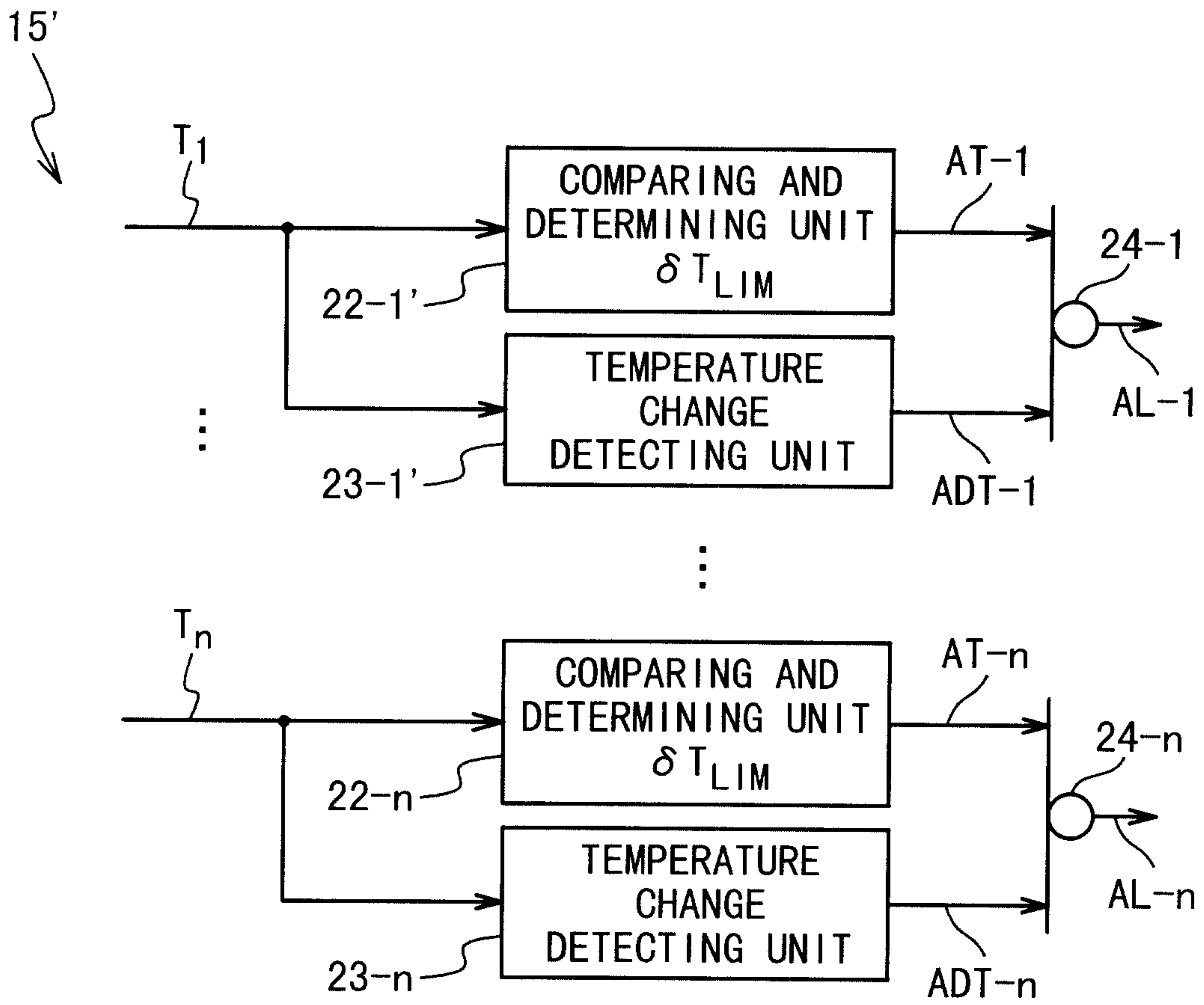

Fig. 7

