

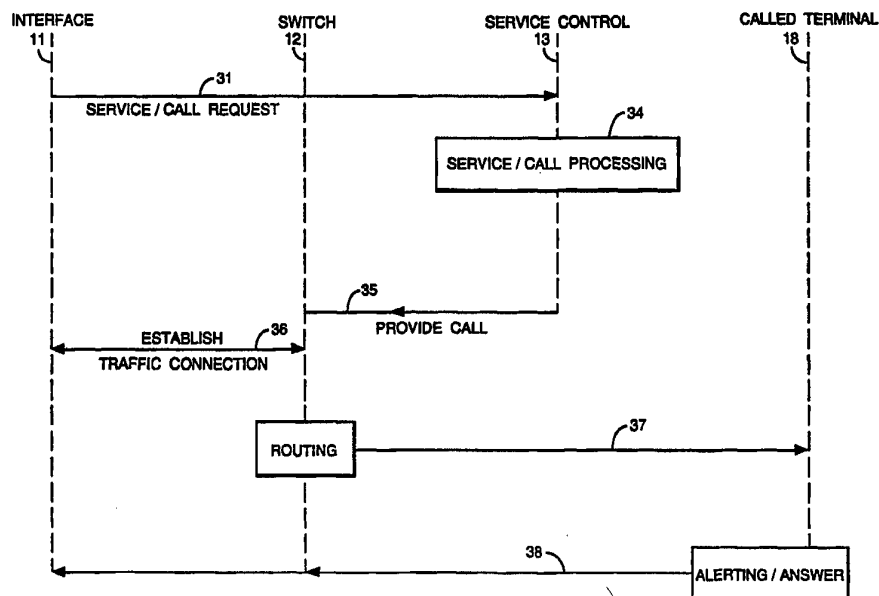

## INTERNATIONAL APPLICATION PUBLISHED UNDER THE PATENT COOPERATION TREATY (PCT)

(51) International Patent Classification <sup>6</sup> : <b>H04Q 3/00</b>	<b>A1</b>	(11) International Publication Number: <b>WO 95/35632</b> (43) International Publication Date: 28 December 1995 (28.12.95)
<p>(21) International Application Number: PCT/GB95/01456</p> <p>(22) International Filing Date: 21 June 1995 (21.06.95)</p> <p>(30) Priority Data: 94304505.4 21 June 1994 (21.06.94) EP</p> <p>(34) Countries for which the regional or international application was filed: AT et al.</p> <p>(71) Applicant (for all designated States except US): BRITISH TELECOMMUNICATIONS PUBLIC LIMITED COMPANY [GB/GB]; 81 Newgate Street, London, EC1A 7AJ (GB).</p> <p>(72) Inventors; and (75) Inventors/Applicants (for US only): LOBLEY, Nigel [GB/GB]; 21 Brunswick Road, Ipswich, Suffolk (GB). CULLEN John, Michael [GB/GB]; 150 Raedweld Road, Bury St Edmunds, Suffolk (GB).</p> <p>(74) Agent: LIDBETTER, Timothy, Guy, Edwin; BT Group Legal Services, Intellectual Property Dept., 13th floor, 151 Gower Street, London WC1E 6BA (GB).</p>		<p>(81) Designated States: AU, CA, CN, FI, JP, KR, NZ, US, European patent (AT, BE, CH, DE, DK, ES, FR, GB, GR, IE, IT, LU, MC, NL, PT, SE).</p> <p><b>Published</b> With international search report.</p>

(54) Title: CALL SETUP AND SERVICE INVOCATION IN TELECOMMUNICATIONS NETWORKS



## (57) Abstract

A telecommunications network has switching means (12) configured such that a request from a first network termination (10) to establish a communications link with a second network termination is directed to the service processing means (13) which directs the switching means (12) to establish the link. This enables the user terminal (10) to direct service and call setup requests directly to the service processing means (13), the switch (12) not being involved with the call or service request until the service processing means (13) instructs it to participate, thereby minimising the establishment and allocation of resources until it is clear that such resources are required. A call can therefore be validated before any communications links are established, thus potentially offering economies in the operation of the system.

**FOR THE PURPOSES OF INFORMATION ONLY**

Codes used to identify States party to the PCT on the front pages of pamphlets publishing international applications under the PCT.

AT	Austria	GB	United Kingdom	MR	Mauritania
AU	Australia	GE	Georgia	MW	Malawi
BB	Barbados	GN	Guinea	NE	Niger
BE	Belgium	GR	Greece	NL	Netherlands
BF	Burkina Faso	HU	Hungary	NO	Norway
BG	Bulgaria	IE	Ireland	NZ	New Zealand
BJ	Benin	IT	Italy	PL	Poland
BR	Brazil	JP	Japan	PT	Portugal
BY	Belarus	KE	Kenya	RO	Romania
CA	Canada	KG	Kyrgystan	RU	Russian Federation
CF	Central African Republic	KP	Democratic People's Republic of Korea	SD	Sudan
CG	Congo	KR	Republic of Korea	SE	Sweden
CH	Switzerland	KZ	Kazakhstan	SI	Slovenia
CI	Côte d'Ivoire	LI	Liechtenstein	SK	Slovakia
CM	Cameroon	LU	Luxembourg	SN	Senegal
CN	China	LK	Sri Lanka	TD	Chad
CS	Czechoslovakia	LV	Latvia	TG	Togo
CZ	Czech Republic	MC	Monaco	TJ	Tajikistan
DE	Germany	MD	Republic of Moldova	TT	Trinidad and Tobago
DK	Denmark	MG	Madagascar	UA	Ukraine
ES	Spain	ML	Mali	US	United States of America
FI	Finland	MN	Mongolia	UZ	Uzbekistan
FR	France			VN	Viet Nam
GA	Gabon				

**CALL SET-UP AND SERVICE INVOCATION IN  
TELECOMMUNICATIONS NETWORKS**

5           The present invention relates to call set-up and service invocation in telecommunications networks, in particular though not exclusively to Intelligent Networks (IN) based telecommunications networks.

          There is currently considerable activity in international standards bodies (CCITT, ISO, etc.) and elsewhere in developing Intelligent Network standards and  
10 implementations. Put simply, the basis of an intelligent network is to separate service provision from switching functionality in telecommunications networks. Typically, the processing required to implement network services is provided by processors which are physically and logically separate from the switching infrastructure and control it. This allows for rapid creation and introduction of new  
15 services without their design or implementation being excessively constrained by the characteristics of the network switches. In particular, a service may be provided throughout a network without the need to modify every individual network switch.

          In present day IN standards (CCITT Capability Set 1 (CS1) and  
20 implementations the logical platform for launching all IN services is a "Basic Call State Model" (BCSM) modelled in the software of each IN switch in a network. The BCSM defines a finite number of states in the lifetime of a telecommunication call, e.g. off-hook, collect digits, etc. Within the BCSM a number of Detection Points (DPs) are identified, at which certain events can trigger a switch to suspend  
25 its call processing and refer to service control entities for further instructions and service-request processing. The service control entity can then control the switch to allow it to continue, terminate or modify its call processing according to the service requested.

          Service control entities are able to modify the call processing by  
30 performing further processing. For example:

- a)       Performing checks upon the validity and account details of the calling user's identity;

b) Obtaining further information to aid call completion: this may include obtaining the routing number, comparing service requests for compatibility, and checking the called party's status, e.g. whether already engaged on another call, and whether diversion or a mailbox facility is available.

5 If a service control entity determines from these further processing steps that a call is to be made, it then returns control of the call to the switch and the call set-up continues with routing, alerting and answer. The elements of the call set-up procedure may have been modified by the service control entity, e.g. if a call diversion is in operation for the called number, or differentiated ringing tones  
10 are in use by the called party for different calling numbers. All service and call requests are initially handled by the switch, the operation of the service control entity being determined by the current status of the switch's BCSM.

Intelligent Networks have great potential for offering advanced network services in the future. It has been proposed to use these principles as the basis for  
15 future fixed and mobile telecommunication systems, and while a number of enhancements needed to achieve this have already been identified, further changes will be required.

The current technique of intelligent network call set-up is illustrated schematically in Figures 1a and 1b. As shown in Figure 1a the logical  
20 interconnection of the schematically illustrated telecommunications network is as follows: a terminal 1 is connected to a switch 2 by a communications link 4, and the switch 2 is connected to a service control unit 3 by means of a control link 6, and to other terminals 8, by means of a communications link 5, either directly or through other switches. The logical communications links 4, 5 are carried over  
25 physical links, which may be permanent (wired) links to fixed terminals or may be dynamically variable links having no permanent physical existence except when required to form a communications connection, for example the radio links in a mobile radio network, or the links in the fixed trunk network (in which the individual physical links are only allocated to individual end-to-end calls for the  
30 duration of those calls).

Figure 1b shows a flow diagram for the operation of the system of figure 1a. A call or other service request is directed by a user from the terminal 1 to the switch 2 (step 21), over the communications link 4. If a call request is made

requiring further processing, the switch recognises this and switch processing is interrupted (step 22). The switch 2 then directs such a request for further processing of the call to the service control unit 3 (step 23), by way of the control link 6. The service control unit 3 provides the checking and further  
5 computation required to create instructions for the switch 2 to complete the call request or to perform some other service request (step 24). In the case of a call request, the service control unit 3 then returns the required instructions to the switch (step 25) to enable the call to be routed and completed (step 27), by allocating a further communications link 5 in order to complete the  
10 communications connection. In practice there will be several interconnected switches 2, each serving a number of terminals 1, and each having access to one or more service control units 3 providing different services. The remote terminal 8 is then alerted to the call and responds (step 28).

On initiation of a request for a call or other transaction (e.g. a service  
15 request) a communications connection, capable of carrying both signalling and call traffic, is established using the communications link 4 between the terminal 1 and the switch 2. Resources in the switch 2 are then dedicated to completion of the connection required. However, the resources may not be required if the service processing step 24 determines that the communications connection 5 to the  
20 remote terminal 8 is not to be completed. When the switch 2 requests processing from the service control unit 3, the service control unit 3 may fail the call and cause the switch 2 to release the connection link 4 due to a service mismatch, customer specific service (such as outgoing calls barred) or called party terminal state (such as the busy condition). This will mean that, in addition to a signalling  
25 channel, a traffic channel will have been connected on the communications link 4 from the user terminal 1 to the switch 2 and in the switch 2 itself, and then not used. Whilst so allocated, these resources cannot be used by other call attempts, which may then fail for lack of available capacity. This is of particular significance in circumstances where the communications link 4 is not permanently allocated to  
30 the terminal 1 as for example in a cellular radio system in which a radio channel is only allocated when a terminal 1 requires it.

According to a first aspect of the invention there is provided a switched telecommunications network for providing communications connections between network terminations, the network comprising:

switching means;

5 two or more network terminations connected to and interconnectable by the switching means to establish communications connections, between the network terminations; and

service processing means for providing services to or for network terminations and/or the switching means;

10 characterised in that the network is configured such that service requests are initially directed from the originating network termination to the service processing means, and that the switching means is controllable by the service processing means.

This invention enables a user terminal to direct service requests (including  
15 call set-up requests) directly to the service processing means, the switch not being involved with the call or service request unless the service processing means then instructs it to participate. Instructions such as call connection may require use of the switch capability, but other, non-call-related instructions, such as setting up a call divert service, will not do so. Certain other functions, such as accessing a  
20 voice mail box, may require a communications connection only between the network termination and a component independent of the main switching function. This invention effectively migrates call and service control functionality from the switch into the service processing means, with the switch's functionality being reduced to a basic switch 'matrix'. The invention also allows the establishment  
25 and allocation of resources to be deferred until it is clear that such resources are required.

According to a second aspect of the invention, there is provided a method of operating a switched telecommunications network for providing communications connections between network terminations, characterised in that service requests  
30 are initially directed from an originating network termination to a service processing means, and the service processing means controls the switched network to provide the service requested.

In this specification the term "service request" embraces a request from a first network termination to establish a communications connection with a second network termination. When the service request is such a request, the service request is directed to the service processing means which controls switching  
5 means to establish the required communications connection. The second network termination to which the first network termination is connected need not necessarily be the one requested. For example, the user of the requested second termination may have diverted incoming calls to another termination.

When a request from a network termination to establish a service not  
10 requiring a communications connection is directed to the service processing means, the service processing means may provide the service without establishing a communications connection between the switch and the network termination. The service processing means may transmit a control message to the network termination. The service processing means may transmit a control message to the  
15 network termination.

In one arrangement the service processing means, on receiving an executable call request from a first network termination, establishes a communication connection through a switching means between the first network termination and a second network termination, and on receiving a service request  
20 or non-executable call request establishes a communication connection with a network termination.

A preferred embodiment of the invention will now be described by way of example, and with reference to the accompanying drawings, wherein:

Figure 1a is a schematic block diagram of the prior art  
25 telecommunications network discussed above;

Figure 1b is a flow chart representing signalling during call set-up/service request in the telecommunications network of Figure 1a;

Figure 2a is a schematic block diagram of a telecommunications network according to the preferred embodiment of the invention; and

30 Figure 2b is a flow chart illustrating signalling during call set-up/service request in the telecommunications network of Figure 2a.

The arrangement and operation of the prior art network of figures 1a and 1b are discussed above.

Referring to figure 2a, a telecommunication network comprises a terminal 10, a network interface unit 11, a switch 12, a service control unit 13, a remote terminal 18 and a voice mailbox 20 associated with the terminal 10. The switch 12 is configured such that a communications connection 19 can be established  
5 between the network interface unit 11 and the switch 12, and a further communications connection 15 can be established between the switch 12 and the remote terminal 18, either directly or through other switches (not shown). A communications connection (not shown) may also be established between the switch 12 and the voice mailbox 20. The terminal 10 is connected to the network  
10 interface unit 11 by a communications link 14, which corresponds to the link 4 in figure 1a. The network interface unit 11 may be a terminal-specific line card in a fixed network, or it may be a base site transceiver in a mobile network (which is dedicated to the terminal 10 only temporarily, until the mobile unit is handed over to another base site or is shut down), but in either case it can be connected to the  
15 switch 12 by a communications connection 19 under the control of the service control unit 13. A further communications connection 19a can be established between the voice mailbox 20 and the network interface unit 11, not involving the switch 12.

A signalling link 17 exists directly between the network interface unit 11  
20 and the service control unit 13. The service control unit 13 includes among its functions control of the switch 12, through a signalling link 16, to establish communications connections over the communications links 19, 15. All control of the switch is handled by the service control unit 13. The service control unit 13 can also, through a signalling link 16a, establish a communications connection  
25 19a between the voice mailbox 20 and the network interface unit 11.

The flow diagram of figure 2b illustrates the information flows between the calling terminal 11, the switch 12, the service control unit 13, and the remote terminal 18, during establishment of a call. At step 31 the user terminal 10 directs a call set-up or service request directly to the service control unit 13, rather than  
30 via the switch 12 as in the prior art arrangement of figure 1a and 1b. The call set-up or service request is passed direct from the network interface unit 11 to the service control unit 13 without any involvement of the switch 12. The service control unit 13 processes the request (step 34) and then sends the



required service and call instructions to the switch 12 (step 35) to enable the call to be processed e.g. by establishing a communications connection 19 in the backward direction (to the network interface unit 11) (step 36). Another communications connection 15 is set up in the forward direction (to the remote terminal 18) (step 37). Once the connections 19, 15 have been established the call is completed as normal (with the remote terminal 18 alerting and answering) (step 38).

The initial call or service set-up stage uses signalling resources 16, 17 only. If the service request is denied at that point then the network has not had to provide any traffic capacity. In other words the call request is validated before the communications links 19, 15 are established, thus offering greater efficiency in the use of the capacity of the system.

If the link 14 between the terminal 10 and the network interface unit 11 is not permanently dedicated to the terminal (as is the case for a cellular network for example), then the communications resources to support this link 14 need not be dedicated to the service or call attempt until the service control unit 13 determines whether they are necessary.

Service requests, including ordinary call requests, are routed from the terminal 10 to the service control unit 13. Some of these service requests may require no communications connection to be set up. For example, if a call is failed, for example because the number dialled does not correspond to a recognised destination, or is barred from use by the originating terminal 10, or because the remote terminal 18 cannot be located (e.g. a switched-off mobile unit), the service control unit 13 may transmit a control message back to the terminal 10, using the signalling connection 17 (in the reverse direction) and the connection 14 (which, as explained above need also only be a signalling connection), to cause the calling terminal 10 to respond in a predetermined manner, such as by displaying an error message. As a specific example, if a terminal 10 is barred from making outgoing calls, or certain classes of outgoing call, the service control unit 13 may transmit a signal to the terminal to cause a suitable message such as '999 calls only' or 'no international calls' to be displayed on a display unit forming part of the terminal 10. Messages may be used for other purposes, such as to indicate the presence of a voice message stored in the voice mailbox 20.

In addition to the switch 12, the network interface unit 11 may be connectable to one or more service terminations by means of further communications links 19a. Such service terminations may, for example, include a 'voice mailbox' 20 for storing messages for the user of the terminal 10 associated with the network interface unit 11. If the service control unit 13 recognises a failed call attempt from a remote terminal 18 to the terminal 10, the service control unit diverts the call via the switch 12 to the voice mailbox 20 instead of to the network interface 11 and thus the terminal 10. This process is essentially that described with reference to figure 2b, the calling terminal in this case being the remote terminal 18, the intended called terminal being the terminal 10, and the actual called terminal (to which the connection is established in step 37) being the voice mailbox 20. The user of the terminal 10 may be advised of the presence of such messages by means of a control message transmitted by the service control unit 13 to the terminal 10 at a suitable time (e.g. the next time the terminal 10 is detected going "on-hook"), as described above.

When the user of the terminal 10 wishes to retrieve the message he transmits a control signal. This control signal is recognised by the service control unit 13, which then transmits a signal to the voice mailbox 20 over the signalling link 16a to establish a direct communications connection 19a between the user's voice mailbox 20 and the network interface unit 11, without the use of the switch 12, to allow the user to replay the previously-stored message.

**CLAIMS**

1. A switched telecommunications network for providing communications connections between network terminations, the network comprising:
- 5 switching means;
- two or more network terminations connected to and interconnectable by the switching means to establish communications connections, between the network terminations; and
- service processing means for providing services to or for network
- 10 terminations and/or the switching means;
- characterised in that the network is configured such that service requests are initially directed from the originating network termination to the service processing means, and that the switching means is controllable by the service processing means.
- 15
2. A switched telecommunications network as claimed in claim 1, further characterised in that the network is configured such that a request from a first network termination to establish a communications connection with a second network termination is directed to the service processing means, and the service
- 20 processing means is operable on receipt of such a request to direct the switching means to establish the communications connection.
3. A switched telecommunications network as claimed in claim 1 or claim 2, further characterised in that the network is configured such that requests from a
- 25 network termination to establish a service not requiring a communications connection are directed to the service processing means, and the service processing means is operable to provide the service without the establishment of a communications connection between the switch and the network termination.
- 30 4. A switched telecommunications network as claimed in claim 3, wherein the service processing means includes means to transmit a control message to the network termination.

5. A switched telecommunications network as claimed in any preceding claim, wherein in addition to the switching means, the network comprises one or more network service terminations selectively connectable to one or more of the network termination means under the control of the service processing means to  
5 provide a communications connection.

6. A method of operating a switched telecommunications network, characterised in that service requests are initially directed from an originating network termination to a service processing means, and the service processing  
10 means controls the switched network to provide the service requested.

7. A method according to claim 6, further characterised in that when the service request is a request from a first network termination to establish a communications connection with a second network termination, the service  
15 request is directed to the service processing means which controls switching means to establish the required communications connection.

8. A method according to claims 6 or 7 wherein when a request from a network termination to establish a service not requiring a communications  
20 connection is directed to the service processing means, the service processing means provides the service without establishing a communications connection between the switch and the network termination.

9. A method according to claim 8, wherein the service processing means  
25 transmits a control message to the network termination.

10. A method according to claim 8 or 9, wherein the service processing means, on receiving an executable call request from a first network termination, establishes a communication connection through a switching means between the  
30 first network termination and a second network termination, and on receiving a service request or non-executable call request establishes a communication connection with a network service termination.

11. A telecommunications network, substantially as described with reference to the accompanying drawings.

12. A method of operating a telecommunications network, substantially as  
5 described with reference to the accompanying drawings.

Fig.1a.

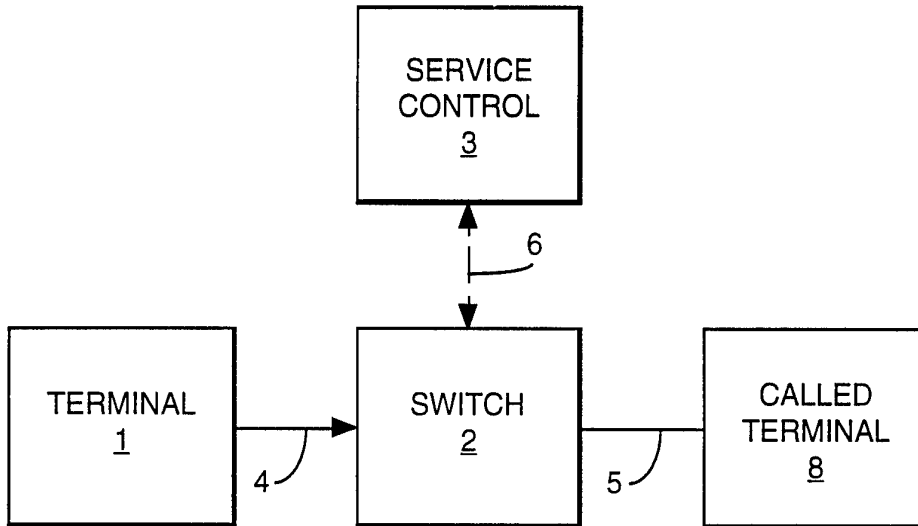
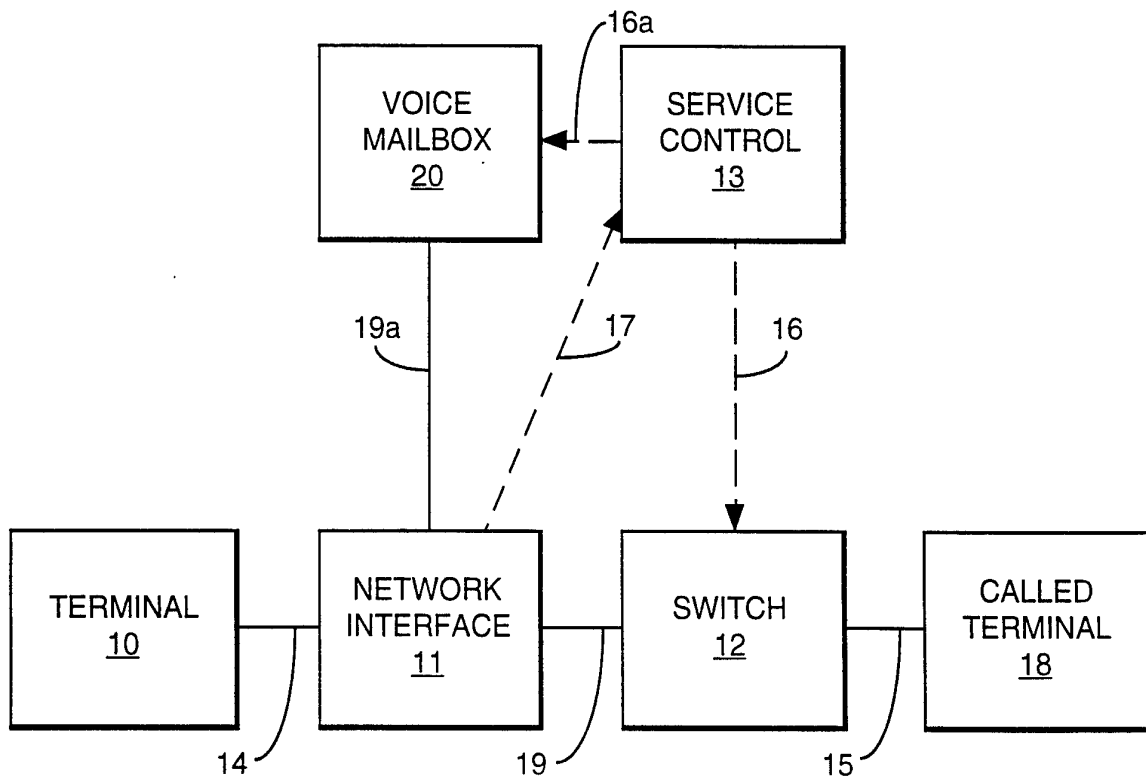

Fig.2a.



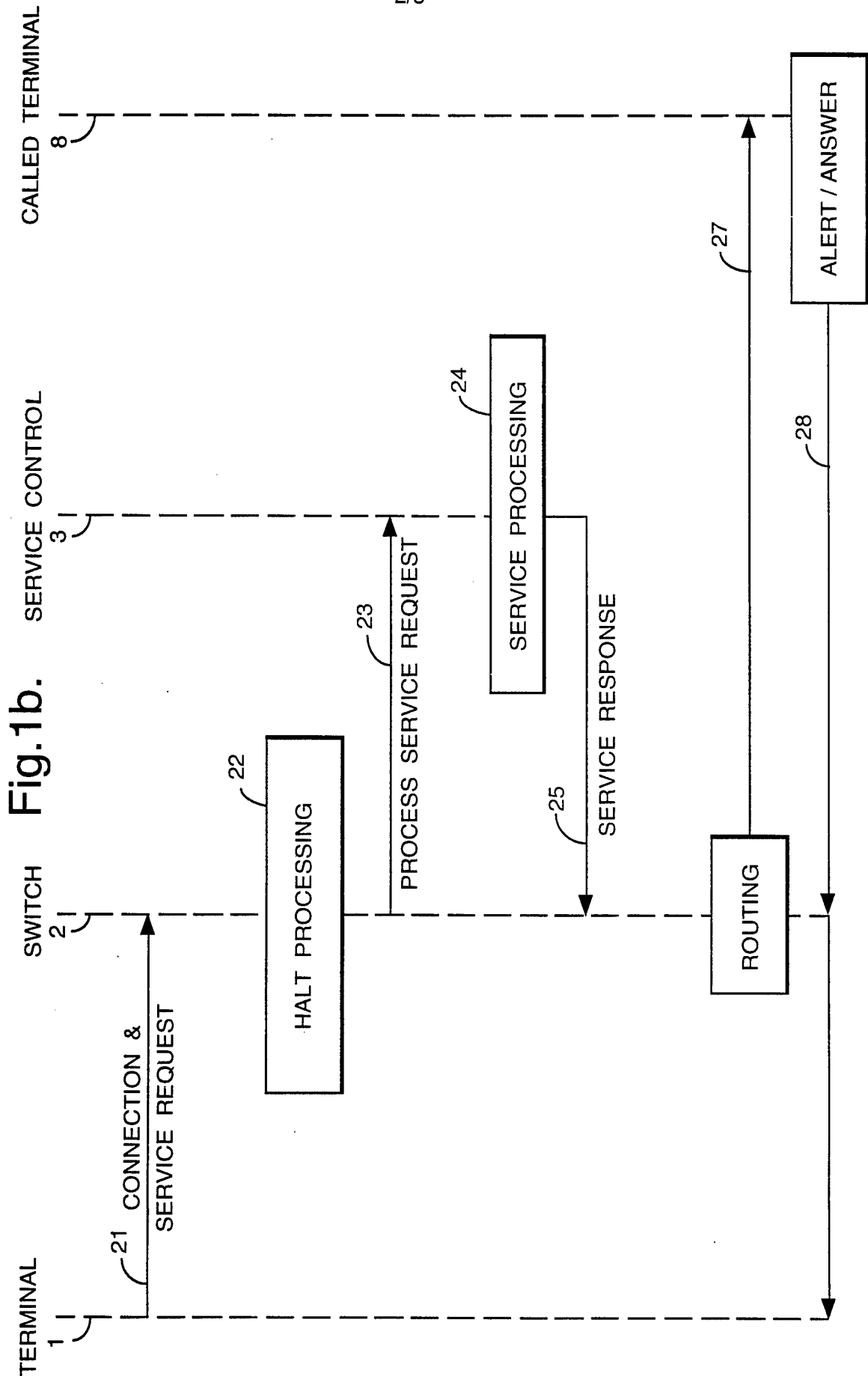
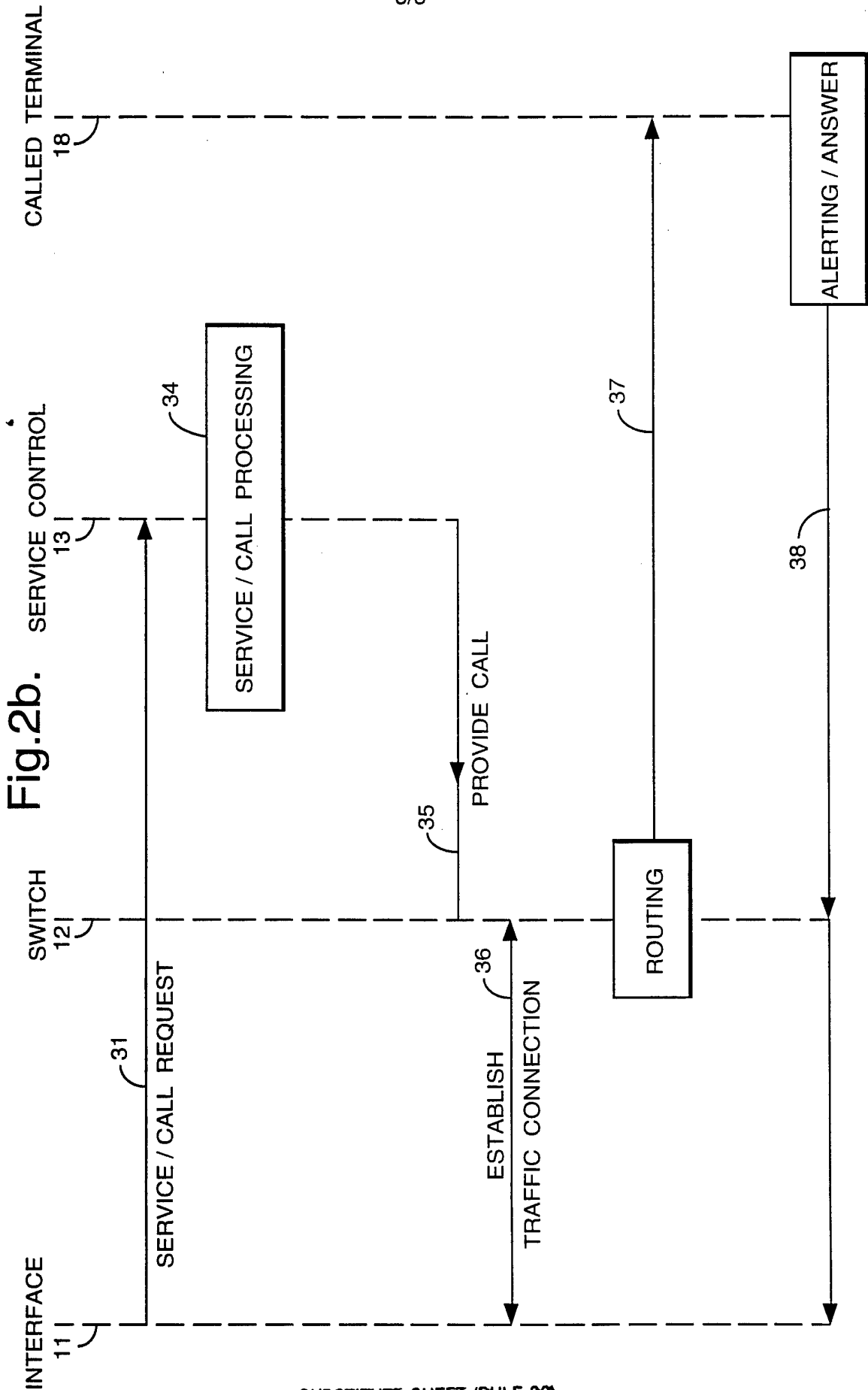

Fig.1b.





# INTERNATIONAL SEARCH REPORT

International Application No  
PCT/GB 95/01456

<b>A. CLASSIFICATION OF SUBJECT MATTER</b> IPC 6 H04Q3/00				
According to International Patent Classification (IPC) or to both national classification and IPC				
<b>B. FIELDS SEARCHED</b>				
Minimum documentation searched (classification system followed by classification symbols) IPC 6 H04Q				
Documentation searched other than minimum documentation to the extent that such documents are included in the fields searched				
Electronic data base consulted during the international search (name of data base and, where practical, search terms used)				
<b>C. DOCUMENTS CONSIDERED TO BE RELEVANT</b>				
Category *	Citation of document, with indication, where appropriate, of the relevant passages	Relevant to claim No.		
X	WO,A,93 16543 (TELEFONAKTIEBOLAGET LM ERICSSON) 19 August 1993 see abstract; claim 1; figures 1,2 see page 16, line 38 - page 18, line 4 ---	1-10		
X	INTERNATIONAL SWITCHING SYMPOSIUM 1990, vol. 4, 28 May 1990 STOCKHOLM SE, pages 63-69, XP 000130899 ORAM ET AL. 'Service location tradeoffs in Intelligent Networks' see section 3.1: 'Local logic'; figure 2 ---	1-4,6-9		
X	US,A,4 910 766 (OGINO ET AL.) 20 March 1990 see column 3, line 1 - line 35; figure 1 --- -/--	1,2,5,6		
<table style="width: 100%; border: none;"> <tr> <td style="width: 50%; border: none;"><input checked="" type="checkbox"/> Further documents are listed in the continuation of box C.</td> <td style="width: 50%; border: none;"><input checked="" type="checkbox"/> Patent family members are listed in annex.</td> </tr> </table>			<input checked="" type="checkbox"/> Further documents are listed in the continuation of box C.	<input checked="" type="checkbox"/> Patent family members are listed in annex.
<input checked="" type="checkbox"/> Further documents are listed in the continuation of box C.	<input checked="" type="checkbox"/> Patent family members are listed in annex.			
* Special categories of cited documents :				
"A" document defining the general state of the art which is not considered to be of particular relevance "E" earlier document but published on or after the international filing date "L" document which may throw doubts on priority claim(s) or which is cited to establish the publication date of another citation or other special reason (as specified) "O" document referring to an oral disclosure, use, exhibition or other means "P" document published prior to the international filing date but later than the priority date claimed	"T" later document published after the international filing date or priority date and not in conflict with the application but cited to understand the principle or theory underlying the invention "X" document of particular relevance; the claimed invention cannot be considered novel or cannot be considered to involve an inventive step when the document is taken alone "Y" document of particular relevance; the claimed invention cannot be considered to involve an inventive step when the document is combined with one or more other such documents, such combination being obvious to a person skilled in the art. "&" document member of the same patent family			
Date of the actual completion of the international search  <p style="text-align: center; font-weight: bold;">3 August 1995</p>	Date of mailing of the international search report  <p style="text-align: center; font-weight: bold;">11.08.95</p>			
Name and mailing address of the ISA European Patent Office, P.B. 5818 Patentlaan 2 NL - 2280 HV Rijswijk Tel. (+ 31-70) 340-2040, Tx. 31 651 epo nl, Fax: (+ 31-70) 340-3016	Authorized officer  <p style="text-align: center; font-weight: bold;">Lambley, S</p>			

INTERNATIONAL SEARCH REPORT

International Application No  
PCT/GB 95/01456

C.(Continuation) DOCUMENTS CONSIDERED TO BE RELEVANT

Category °	Citation of document, with indication, where appropriate, of the relevant passages	Relevant to claim No.
X	<p>TELETRAFFIC SCIENCE, PROCEEDINGS OF THE 12TH INTERNATIONAL TELETRAFFIC CONGRESS, no. 1, 1989 AMSTERDAM NL, pages 447-454, XP 000279779 GIRIDHARAGOPAL ET AL. 'Intelligent Networks: Demands on provisioning and performance' see page 451, paragraph 3 - page 452, paragraph 4; figures 5,6 -----</p>	2,7
A	<p>EP,A,0 518 344 (ALCATEL SEL AKTIENGESELLSCHAFT) 16 December 1992 see column 2, line 10 - column 3, line 16; figure -----</p>	2,7

# INTERNATIONAL SEARCH REPORT

Information on patent family members

International Application No <b>PCT/GB 95/01456</b>
--

Patent document cited in search report	Publication date	Patent family member(s)	Publication date
WO-A-9316543	19-08-93	SE-C- 500822	12-09-94
		AU-B- 3578093	03-09-93
		CA-A- 2129548	18-08-93
		CN-A- 1079091	01-12-93
		EP-A- 0627145	07-12-94
		FI-A- 943766	05-10-94
		JP-T- 7503822	20-04-95
		NO-A- 943026	16-08-94
		SE-A- 9200470	18-08-93
		US-A- 5414752	09-05-95
US-A-4910766	20-03-90	JP-A- 1233949	19-09-89
EP-A-0518344	16-12-92	DE-A- 4119672	17-12-92
		AU-B- 646164	10-02-94
		AU-A- 1800492	24-12-92
		JP-A- 5183954	23-07-93
		NZ-A- 243068	27-04-95
		US-A- 5345502	06-09-94