

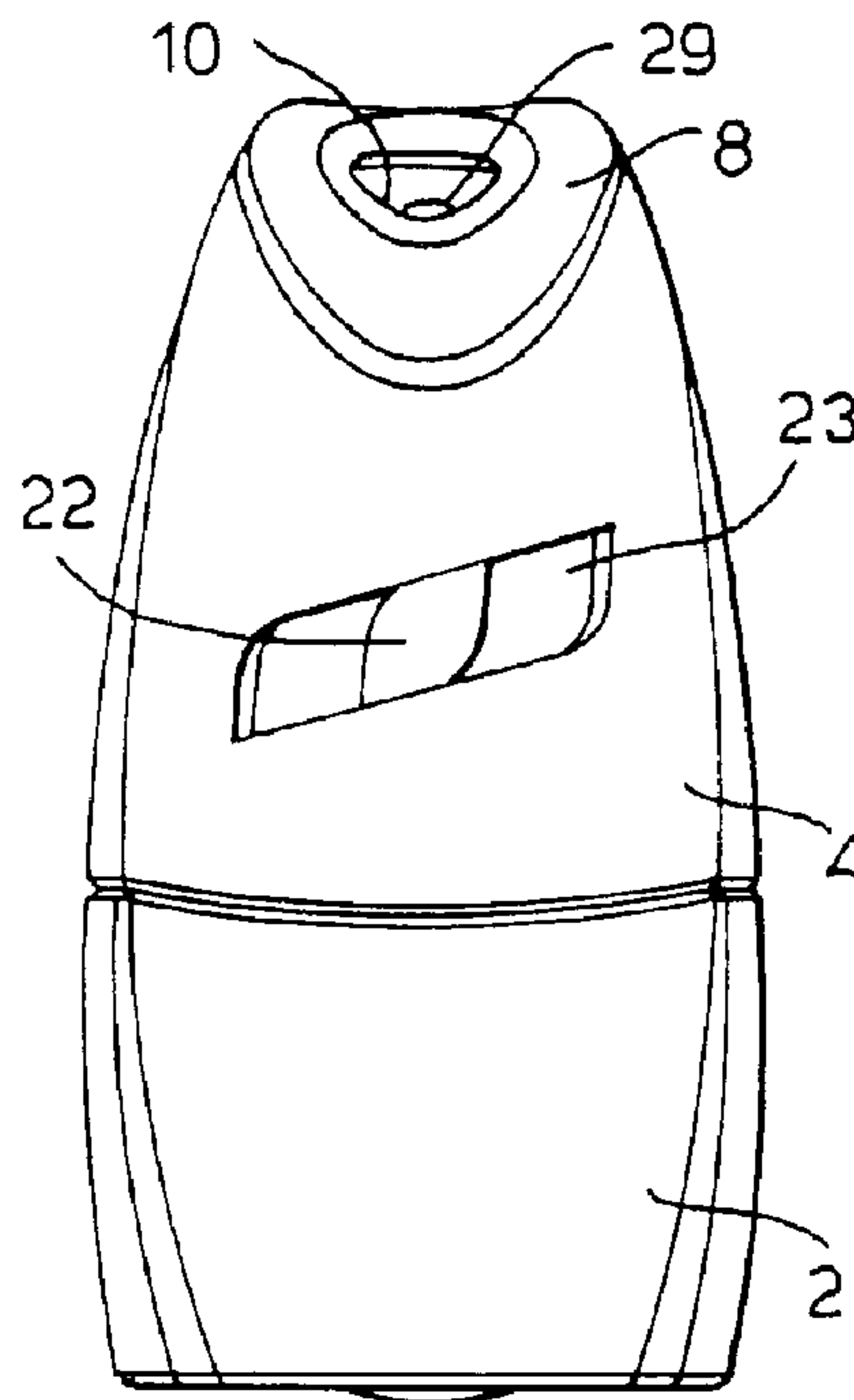

(86) Date de dépôt PCT/PCT Filing Date: 2000/09/25  
 (87) Date publication PCT/PCT Publication Date: 2001/03/29  
 (45) Date de délivrance/Issue Date: 2008/02/19  
 (85) Entrée phase nationale/National Entry: 2002/03/11  
 (86) N° demande PCT/PCT Application No.: GB 2000/003663  
 (87) N° publication PCT/PCT Publication No.: 2001/021226  
 (30) Priorités/Priorities: 1999/09/24 (GB9922599.7);  
 1999/12/04 (GB9928590.0)

(51) Cl.Int./Int.Cl. *A61L 9/03* (2006.01),  
*A01M 1/20* (2006.01)  
 (72) Inventeur/Inventor:  
 RYMER, SHAUN, GB  
 (73) Propriétaire/Owner:  
 RECKITT BENCKISER (UK) LIMITED, GB  
 (74) Agent: FETHERSTONHAUGH & CO.

(54) Titre : DISPOSITIF ELECTRIQUE DE VAPORISATION D'UN LIQUIDE VOLATIL  
 (54) Title: ELECTRICAL DEVICE FOR EVAPORATING A VOLATILE LIQUID



(57) **Abrégé/Abstract:**

An electrical device for evaporating a volatile liquid (for example an air freshener) into a room employs a wick (14) which extends upwardly from a container of the volatile liquid. A ring heat (16) is in the vicinity of the end of the wick, and assists the evaporation. Vapour escapes from the device through an aperture (10) above the wick, in a casing. The vapour emission rate is controlled by a user, who operates a control member in the casing, to alter the vertical position of a tubular body (18). Vapour may flow from the wick to the exterior through the tubular body (18), and then through the aperture (10). However in all positions of the tubular body vapour may also flow to the aperture, and thence to the exterior, by an auxiliary route, not through the tubular body. It is found that the provision of this auxiliary route for vapour significantly improves the performance of the device. The tubular body (18) comprises an upper surface (31) comprising a wall (32) and apertures (33). The wall (32) together with the apertures (33) ensures that any unevaporated volatile liquid is directed back towards the heater.

## (12) INTERNATIONAL APPLICATION PUBLISHED UNDER THE PATENT COOPERATION TREATY (PCT)

(19) World Intellectual Property Organization  
International Bureau(43) International Publication Date  
29 March 2001 (29.03.2001)

PCT

(10) International Publication Number  
**WO 01/21226 A1**

- (51) International Patent Classification<sup>7</sup>: A61L 9/03, [GB/GB]; 6 Berkshire Close, Beverley, East Yorkshire HU17 8UW (GB).  
A01M 1/20
- (21) International Application Number: PCT/GB00/03663
- (22) International Filing Date: 25 September 2000 (25.09.2000)
- (25) Filing Language: English
- (26) Publication Language: English
- (30) Priority Data:  
9922599.7 24 September 1999 (24.09.1999) GB  
9928590.0 4 December 1999 (04.12.1999) GB
- (71) Applicant (for all designated States except US): RECKITT BENCKISER (UK) LIMITED [GB/GB]; 67 Alma Road, Windsor, Berkshire SL4 3HD (GB).
- (72) Inventor; and
- (75) Inventor/Applicant (for US only): RYMER, Shaun
- (74) Agent: ELIZABETH, Anne, Dickson; Reckitt Benckiser plc, Group Patents Department, Dansom Lane, Hull HU8 7DS (GB).
- (81) Designated States (national): AE, AG, AL, AM, AT, AU, AZ, BA, BB, BG, BR, BY, BZ, CA, CH, CN, CR, CU, CZ, DE, DK, DM, DZ, EE, ES, FI, GB, GD, GE, GH, GM, HR, HU, ID, IL, IN, IS, JP, KE, KG, KP, KR, KZ, LC, LK, LR, LS, LT, LU, LV, MA, MD, MG, MK, MN, MW, MX, MZ, NO, NZ, PL, PT, RO, RU, SD, SE, SG, SI, SK, SL, TJ, TM, TR, TT, TZ, UA, UG, US, UZ, VN, YU, ZA, ZW.
- (84) Designated States (regional): ARIPO patent (GH, GM, KE, LS, MW, MZ, SD, SL, SZ, TZ, UG, ZW), Eurasian patent (AM, AZ, BY, KG, KZ, MD, RU, TJ, TM), European patent (AT, BE, CH, CY, DE, DK, ES, FI, FR, GB, GR, IE, IT, LU, MC, NL, PT, SE), OAPI patent (BF, BJ, CF, CG, CI, CM, GA, GN, GW, ML, MR, NE, SN, TD, TG).

[Continued on next page]

(54) Title: ELECTRICAL DEVICE FOR EVAPORATING A VOLATILE LIQUID

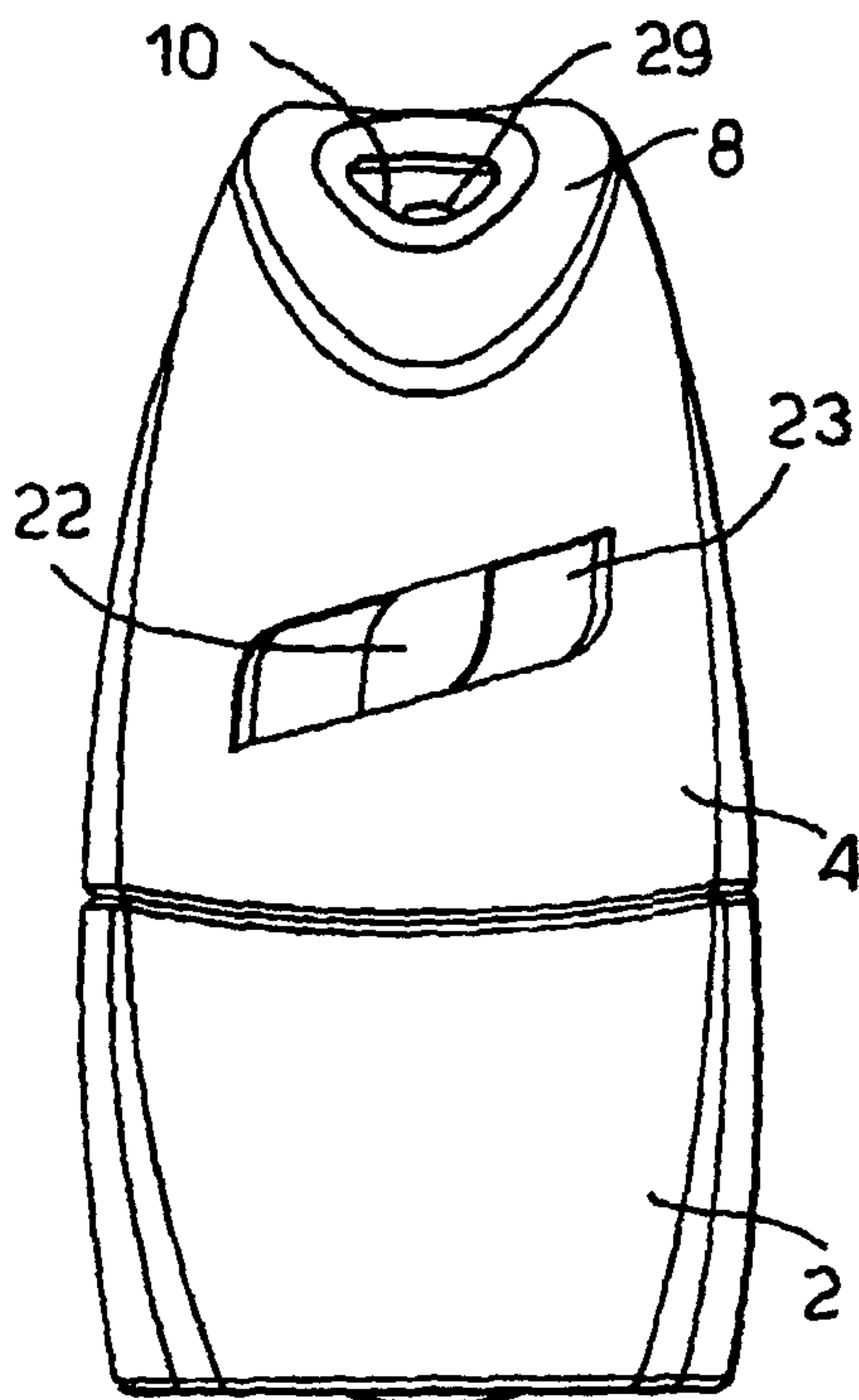

(57) Abstract: An electrical device for evaporating a volatile liquid (for example an air freshener) into a room employs a wick (14) which extends upwardly from a container of the volatile liquid. A ring heater (16) is in the vicinity of the end of the wick, and assists the evaporation. Vapour escapes from the device through an aperture (10) above the wick, in a casing. The vapour emission rate is controlled by a user, who operates a control member in the casing, to alter the vertical position of a tubular body (18). Vapour may flow from the wick to the exterior through the tubular body (18), and then through the aperture (10). However in all positions of the tubular body vapour may also flow to the aperture, and thence to the exterior, by an auxiliary route, not through the tubular body. It is found that the provision of this auxiliary route for vapour significantly improves the performance of the device. The tubular body (18) comprises an upper surface (31) comprising a wall (32) and apertures (33). The wall (32) together with the apertures (33) ensures that any unevaporated volatile liquid is directed back towards the heater.

WO 01/21226 A1

## ELECTRICAL DEVICE FOR EVAPORATING A VOLATILE LIQUID

This invention relates to a device for evaporating volatile liquids, for example air fresheners and insecticides. The invention relates in particular to a device for evaporating volatile liquids from a container into a room, with the assistance of electrical power.

Devices are known, in which a bottle of volatile liquid has a wick projecting from it, and a heater is located in the vicinity of the distal end of the wick, to accelerate the evaporation of volatile liquid from the wick. The bottle, wick and heater are retained within a casing which carries an electric plug. To operate the heater the device is plugged into a wall socket.

Such devices are known, which purport to offer control of the rate of evaporation of the volatile liquids. In one device, described in Spanish patent application No. 9701388, the rate of evaporation is altered by varying the relative position of the wick and the heater (which typically is ring-shaped). In this patent application there is described a means for moving the container and the wick axially, through the action of a screw thread, whilst the ring heater is kept stationary.

In one device on the market, the relative movement of a ring heater and a wick is achieved by keeping the wick stationary and moving the heater axially.

25448-190

- 2 -

In another device on the market, a tiltable barrel device is located at the distal end of the wick. This may be tilted about a horizontal axis to alter the air flow pathways at the distal end of the wick, and thereby alter  
5 the rate of evaporation.

However, we have found all such devices to be unsatisfactory in giving good adjustment. Indeed, in our tests we have sometimes found that the rate of evaporation of volatile liquids when the device is in its minimum  
10 setting to be higher than the rate of evaporation when the device is in its supposed maximum setting.

In accordance with a first aspect of the present invention there is provided a device for evaporating a volatile liquid, the device comprising: a container for the  
15 volatile liquid; a wick which has a proximal end region within the container, with the proximal end thereof adjacent to the base of the container, and a distal end region above the container; an electrical heater able to provide heat to the distal end region of the wick; a casing which extends  
20 over the container and wick, and which has an aperture above the distal end of the wick; and a tubular body in the region between the distal end of the wick and the casing, the tubular body being movable between highest and lowest positions to alter the rate of emission from the device of  
25 vapour evaporated from the wick; wherein the vapour has a flow pathway from the wick to the exterior of the device through the tubular body, and wherein, when the tubular body is in its highest position, the vapour has an auxiliary flow pathway from the wick to the exterior of the device, which  
30 auxiliary flow pathway is not through the tubular body.

25448-190

3 -

In accordance with a second aspect of the present invention there is provided a tubular body forming part of a device for evaporating a volatile liquid, the device comprising:

- 5 a container for the volatile liquid;  
a wick which has a proximal end region within the container, with the proximal end thereof adjacent to the base of the container, and a distal end region above the container;
- 10 an electrical heater able to provide heat to the distal end region of the wick;  
a casing which extends over the container and the wick, and which has an aperture above the distal end of the wick;
- 15 characterised in that the tubular body is located in the region between the distal end of the wick and the casing, the tubular body being movable between highest and lowest positions to alter the rate of emission from the device of vapour evaporated from the wick;
- 20 wherein the vapour has a flow pathway from the wick to the exterior of the device through the tubular body, and wherein when the tubular body is in its highest position, the vapour has an auxiliary flow path away from the wick to the exterior of the device, which auxiliary flow path
- 25 is not through the tubular body.

4 -

In our tests of such devices we have found that the highest position of the tubular body is the position at which the evaporation rate is at a maximum; and that it is better, in this position, to provide such an auxiliary  
5 flow pathway, than to require that all of the vapour escaping from the device into the exterior must pass through the tubular body.

However, it has been found that in certain  
10 conditions, such as when the tubular body is in its highest position, despite the auxiliary flow pathway which increases the rate of evaporation of the volatile liquid, a proportion of the liquid does not evaporate. This non-evaporated liquid escapes from the container,  
15 often running down internal surfaces of the container. This can become visible on certain external parts of the container. This is undesirable and unacceptable as the escaping liquid is unsightly and may cause damage to areas near to the device.

20

Advantageously, the tubular body comprises an upper surface lying in a plane substantially at right angles to the axis of the tubular body, the surface comprising a wall extending around at least a part of the  
25 circumference of the upper surface, and extending in a direction substantially perpendicular to the surface and away from the lower end of the tubular body.

The wall acts as a dam redirecting any unevaporated  
30 liquid towards the heater in order that the liquid may be reheated.

5 -

The presence of the wall thus ensures that any unevaporated liquid is returned towards the heater where it is heated again. This process eliminates or at least significantly reduces the proportion of volatile liquid which does not eventually evaporate during the heating process, and substantially eliminates liquid from becoming visible on certain external parts of the container.

10 Alternatively, or in addition, the tubular body contains one or more apertures formed in the upper surface. The one or more apertures allow liquid to escape towards the heater.

15 The surface may be substantially the same size and shape as the cross sectional area of the tubular body, but preferably, the upper surface has a greater radius than that of the cross sectional area of the tubular body.

20 Preferably the upper surface is positioned coaxially with the tubular body. Because the upper surface of the tubular body is larger in area than the cross-sectional area of the tubular body, an upper surface is created which extends beyond that of the tubular body, and provides a greater catchment area for unevaporated liquid, thus reducing further the proportion of unevaporated liquid which is able to escape from the device.

30 In one embodiment the upper region of the casing may be provided with one or more separate openings, in

6 -

addition to said aperture which is above the distal end of the wick. For example, there may be an array of openings around the said aperture, so that the top of the casing has one said aperture and further openings, preferably smaller openings, of "pepper-pot" type.

In another embodiment, there may be a space between the upper end of the tubular body and the casing, in the highest position of the tubular body, through which space vapour may flow. Thus the auxiliary flow pathway may be past the lower end of the tubular body, up the outside of the tubular body, over the upper end of the tubular body, through the said space, and out through the said aperture above the tubular body. Such embodiments have been shown to be very effective and are preferred embodiments of the present invention.

A further advantage of the wall forming part of the upper surface of the tubular body in a preferred embodiment of the invention is that the wall prevents the upper end of the tubular body from making contact with the casing thus ensuring that there is a space between the upper end of the tubular body and the casing in the highest position of the tubular body. This enhances evaporation of the volatile liquid.

A said space between the upper end of the tubular body and the casing may be an annular space. Stop means may be provided to prevent the tubular body reaching the casing in the highest position.

7-

Alternatively, the device may be such that the tubular body contacts the casing in the highest position of the tubular body, with one or more openings being provided, in the upper region of the tubular body or in  
5 the part of the casing which contacts the tubular body. Such an opening is suitably of cut-out shape, by which we mean it extends to the end of the respective part.

In one embodiment, the upper end of the tubular body  
10 may suitably have one or more openings of cut-out shape. Thus, it may be of castellated form. Alternatively, a downwardly dependent skirt may project from said aperture, and the skirt may have one or more openings, suitably of cut-out shape. Thus, it may be of  
15 castellated form, with the castellations facing in the downward direction.

Preferably the said aperture in the casing above the distal end of the wick is of substantially the same size  
20 and shape as the tubular body, in horizontal cross section.

Suitably the ratio of the cross-sectional area of the said space or opening, or of said openings in total  
25 when there is more than one, to the transverse cross-sectional area of the flow pathway within the tubular body, is in the range 1:5 to 5:1, preferably 1:3 to 3:2, more preferably 1:2 to 1:1, and especially 6:10 to 9:10. In devices in which the size of said space or of said  
30 opening(s) is at a minimum when the tubular body is in its highest position these ratios refer to the situation when the tubular body is in its highest position.

8 -

There is a gap between the lower end of the tubular body and the heater at least when the tubular body is in its highest position. Such a gap is preferably smaller in cross-sectional area than the horizontal cross-sectional area of the flow pathway within the tubular body. The ratio thereof may suitably be no more than 1:2, preferably no more than 1:5, most preferably no more than 1:10. Such a gap is suitably smaller in area than the area of said opening, or of said openings in total when there is more than one. The ratio thereof may suitably be no more than 1:2, preferably no more than 1:5, most preferably no more than 1:10.

Preferably, the heater and the wick are in fixed positions, in the casing.

An important feature of this invention is that there be provided a said auxiliary flow pathway when the tubular body is in its highest position. Such an auxiliary flow pathway is preferably also provided in all other positions of the tubular body, including in its lowest position.

A further important feature of this invention is that means is provided for allowing unevaporated volatile liquid to be redirected back towards the heater.

Suitably the heater is a ring heater, as is conventional, and the wick is aligned with the central axis of the ring heater. Preferably, the distal end region of the wick is within the hole defined by the ring heater.

9 -

Suitably the ring heater comprises an electrical resistor. Preferably it is a thermistor. Preferably, it is powered by mains electricity, and the device is provided with plug formations to enable it to be operated  
5 from a mains electrical socket.

When a device is provided with plug formations and has said one or more openings in the upper end of the tubular body or in the lower end of a said downwardly  
10 dependent skirt, preferably there is also such an opening facing towards the plug formations (furthest from the plug formations). Preferably, there are two further openings centred on positions about 90° around from the centre of the opening which faces away from the plug  
15 formations. Preferably there is such an opening facing away from the plug formations (nearest to the plug formations). Thus, in especially preferred embodiments there are at least four such openings.

20 Preferably the tubular body does not overlies the distal end of the wick, even in the lowest position of the tubular body.

Suitably the tubular body is within a hole defined  
25 by the ring heater, even in its lowest position. Preferably, the lower end of the tubular body is substantially in the plane of the upper surface of the ring heater, when the tubular body is in its highest position.

30

10 -

Preferably, the lower end of the tubular body is above the distal end of the wick, even in the lowest position of the tubular body.

5 The invention will now be further described, by way of example, with reference to the accompanying drawings, in which:

Fig. 1 shows a front view of a device in accordance with  
10 the invention;

Fig. 2 shows a plan view of the device of Fig. 1;

Fig. 3 is a perspective view of the upper region of the  
15 device of Fig. 1;

Fig. 4 is a sectional view through line A-A<sup>1</sup> in Fig. 2, showing the upper region of the device set for its maximum vapour emission rate;

20

Fig. 5 is a schematic sectional view of the upper region of a second embodiment of a device in accordance with the invention, set for an intermediate vapour emission rate;

25 Fig. 6 is a schematic sectional view of a third embodiment of a device in accordance with the invention, set for its maximum vapour emission rate;

Fig. 7 is a schematic view of the upper surface of the  
30 tubular body according to the second aspect of the present invention and forming part of the device shown in figures 1 to 6; and

11 -

Fig. 8 is a view of the tubular body of fig. 7 from one side showing its position relative to the slanted top face of the casing.

5

The device of Figs. 1 to 4 has a container in the form of a replaceable glass bottle 2 containing a volatile air freshener liquid, and a plastics casing 4 which extends over the opening of the container, and also behind it. From the rear wall of the container above the casing extends an electrical plug 6. In this embodiment it is a British-style three-pin plug but of course for other countries the appropriate plug will be employed; often a two-pin plug. The top of the casing is, for aesthetic reasons, somewhat downwardly inclined in the forward direction such that the casing terminates in a discrete slanted top face 8. Within the slanted top face there is a generally circular central aperture 10, defined by a downwardly depending skirt 12. Projecting vertically upwards from the container is a cylindrical wick 14, the distal end region of which is shown in Fig. 4. The diameter of the wick is 6.8 mm. The proximal end of the wick is within the container adjacent to its bottom. Adjacent to the distal end region of the wick is a positive temperature coefficient (PTC) thermistor. The wick 14, the ring heater 16 and the aperture 10 are all axially aligned.

There is a space between the ring heater 16 and the lower end of the skirt 12, and within this space there is located a tubular body 18. The tubular body 18 has a circularly cylindrical wall 19 and, at its top end, a

12 -

collar 20. Its bore is circularly cylindrical from end to end and the bore diameter is 8.4 mm. The tubular body 18 has its axis aligned with the axis of the aperture, wick and ring heater. The tubular body 18 may be moved  
5 up and down under the control of the user with a traverse indicated by the double-headed arrow 21 in Fig. 4. The tubular body 18 is connected by a connecting body (not shown in the drawings, for clarity) to a control member 22 exposed to the exterior, and constrained to move  
10 within an inclined guideway 23 in the casing. When the control member 22 is in its highest position within the guideway 23 (at the right-hand end of the guideway as shown in Fig. 1) the tubular body 18 is located in its highest position, as shown in Fig. 4. In this position  
15 the delivery of vapour from the wick to the exterior of the device is at its maximum. When the control member 22 is in its lowest position (at the left-hand end of the guideway shown in Fig. 1) the tubular body 18 is at its lowest position, with the top of the tubular body at the  
20 level of the bottom arrow head of arrow 21, in Fig. 4, and delivery of vapour in this position is at a minimum.

The slanted top face 8 of the casing is moulded with an oval depression around the opening 10, for aesthetic  
25 reasons. The boundary 24 of this oval depression is shown most clearly in Fig. 3.

The wick 14 is vertical in use and its circular distal end 26 is horizontal. Its distal end 26 is located  
30 in the hole defined by the ring heater 16. It will be apparent from Fig. 4 that even in the lowest position of the tubular body 18, it does not pass over the wick 14.

13 -

In the highest position of the tubular body 18 the plane of its lower end is substantially in the plane of the upper surface of the ring heater 16. In other positions of the tubular body 18 its lower end is in the hole defined by the ring heater. The external diameter of the wall 19 of the tubular body is 9.8 mm and the diameter of the cylindrical hole within the ring heater is 9.9 mm. Thus, any vapour rising under convection from the wick and not passing through the bore of the tubular body 18 has an annular gap of 0.1 mm thickness to pass through. The area of this gap is approximately 1.5 mm<sup>2</sup>. Thus, in all positions of the tubular body vapour evaporating from the wick can pass through the tubular body, or can pass through the gap between the tubular body and the ring heater.

The downwardly depending skirt 12, which defines a generally cylindrical passageway leading to the circular aperture 10, has four openings 29 of cut-out shape, extending to the bottom of the skirt. Each opening shown in Fig. 4 is 4 mm wide and 3 mm high. The other opening, not shown, which faces away from the plug (nearest to the plug) is 4 mm wide and 1 mm high. The position of all four openings may just be seen, marked in black, in Fig. 2. The openings are centred on positions 90° around from each other. It will be apparent that when the device is set to its maximum vapour emission rate, with the tubular body at its highest position as shown in Fig. 4, vapour can pass to the aperture 10 through the tubular body, or can by-pass it, by flowing through the gap between the lower end of the tubular body and the upper end of the ring heater, up outside the tubular body, and then enter

14 -

the aperture via the openings 29. The pathways by which vapour can flow to the exterior of the device are marked with arrows in Fig. 4.

5 We have found that enabling vapour to leave the device by an auxiliary flow pathway, not through the tubular body, brings about a marked improvement in operation of the device, in particular in preventing the condensation of vapour within the device.

10

In a second embodiment shown in Fig. 5 the tubular body is a simple circular cylinder and the heater is of simpler design, but it provides an auxiliary flow pathway in the same manner as the first embodiment. However  
15 there are only three openings, the ones visible in Fig. 5. There is no opening facing away from the plug (nearest to the plug). The tubular body 18 of the Fig. 5 embodiment is shown in an intermediate position. It will be apparent that the gap 30 between the ring heater and  
20 the tubular body in this intermediate position (and in higher positions) is larger than in the first embodiment.

In a further embodiment (not shown) the downwardly depending skirt does not have any apertures, but  
25 terminates in a circular face. Thus, the skirt seals against the tubular body, in the highest position of the latter. Instead the upper end of the tubular body is castellated, and so has apertures, preferably four, of cut-out shape.

30

A further embodiment is shown in Fig. 6. In this embodiment the downwardly depending skirt is not

15 -

castellated. Nor is the upper end of the tubular body 18  
castellated. Rather, in the highest position of the  
tubular body, shown in Fig. 6, it is slightly spaced from  
the lower end of the downwardly depending skirt 12. This  
5 may be achieved simply by designing the device so that  
that a space is left, when the control member 20 abuts  
the upper end of the guideway 22. Thus, an annular space  
is part of the auxiliary flow pathway for vapour. The  
pathways by which vapour can flow to the exterior of the  
10 device are marked with arrows in Fig 6.

Referring to Figs. 7 and 8 a further embodiment of  
the tubular member is shown. The tubular body 18  
comprises an upper surface 31 lying in a plane  
15 substantially at right angles to the axis of the tubular  
body 18.

The upper surface 31 comprises a wall 32 which  
extends above the upper surface 31 substantially at right  
20 angles to the upper surface 31. The wall 32 extends  
partially around the circumference of the upper surface  
31 .

The upper surface further comprises one or more  
25 apertures 33. Although two apertures are shown in the  
embodiment illustration Figs. 7 and 8, any other number  
of apertures could also be used.

It has been found that in certain positions of the  
30 tubular body 18, particularly when the tubular body is at  
it's highest position, a certain proportion of volatile  
liquid does not evaporate and therefore remains in liquid

16 -

form. The upper surface 31 serves to catch unevaporated liquid. The wall 32 serves as a dam directing the caught liquid through the tubular body 18 or through the apertures 33 and back towards the heater. The  
5 unevaporated liquid is then heated up again and may now evaporate. Any liquid which does not evaporate is again directed back towards the heater due to the presence of the dam 32 and the apertures 33. Through this  
10 reiterative process eventually most if not all of the liquid will evaporate thus overcoming the problem of unevaporated liquid escaping from the device.

The upper surface of the tubular body extends beyond the outer surface of the tubular body and therefore  
15 provides a large catchment area for unevaporated liquid.

The wall 32, as well as serving as a dam for unevaporated liquid, also serves to ensure that there is always a gap 34 between the casing and the upper surface  
20 of the tubular body. This arrangement further enhances the auxiliary flow paths and increases ventilation within the device. This ensures greater evaporation of the volatile liquid.

25 In a further embodiment (not shown) there are no openings defined as between the tubular body and the downwardly depending skirt, and these parts abut in the highest position of the tubular body, so that no flow pathway is defined between them. Instead, openings are  
30 provided in the slanted top face 8 of the casing, around the central aperture 10. Preferably there are twelve such openings, in a circular array.

CLAIMS

1. A device for evaporating a volatile liquid, the device comprising:
- 5 a container for the volatile liquid;  
a wick which has a proximal end region within the container, with the proximal end thereof adjacent to the base of the container, and a distal end region above the container;
- 10 an electrical heater able to provide heat to the distal end region of the wick;  
a casing which extends over the container and wick, and which has an aperture above the distal end of the wick;
- 15 and a tubular body in the region between the distal end of the wick and the casing, the tubular body being movable between highest and lowest positions to alter the rate of emission from the device of vapour evaporated from the wick;
- 20 wherein the vapour has a flow pathway from the wick to the exterior of the device through the tubular body, and wherein, when the tubular body is in its highest position, the vapour has an auxiliary flow pathway from the wick to the exterior of the device,
- 25 which auxiliary flow pathway is not through the tubular body.
2. A device as claimed in claim 1, wherein the auxiliary flow pathway leads vapour to said aperture.
- 30 3. A device as claimed in claim 1 or 2, wherein there is a space between the upper end of the tubular body and

18 -

the casing, in the highest position of the tubular body, the space being part of the auxiliary flow pathway.

- 5 4. A device according to any one of claims 1 to 3  
wherein the tubular body comprises an upper surface  
lying in a plane substantiated right angles to the  
axis of the tubular body, the surface comprising a  
wall extending substantially perpendicularly from the  
10 upper surface, around at least part of the  
circumference of the upper surface, and extending in  
a direction away from the lower end of the tubular  
body.
- 15 5. A device according to any one of claims 1 to 4  
wherein the tubular body contains one or more  
apertures formed in the upper surface.
- 20 6. A device as claimed in any one of claims 1 to 5,  
wherein a downwardly dependent skirt projects from  
said aperture, wherein the lower end of the skirt has  
one or more openings of cut-out shape, and wherein in  
the highest position of the tubular body the upper  
end of the tubular member abuts the lower end of the  
25 skirt.
7. A device as claimed in claim 6, wherein the lower end  
of the skirt is of inverted castellated form, having  
a plurality of openings of cut-out shape.
- 30 8. A device as claimed in any one of claims 1 to 5,  
wherein the upper end of the tubular body has one or

more openings of cut-out shape, and wherein in the highest position of the tubular member the upper end of the tubular member abuts the casing.

- 5 9. A device as claimed in claim 8, wherein the upper end of the tubular body is of castellated form, having a plurality of openings of cut-out shape.
- 10 10. A device as claimed in any one of claims 1 to 9 wherein there is provided an array of additional openings, around the said aperture, providing auxiliary flow pathways.
- 15 11. A device as claimed in claim 3 or claim 10 wherein, in the highest position of the tubular body, the ratio of the cross-sectional area of the said space or of said opening, or of said openings in total, to the cross-sectional area of said aperture is in the range 1:5 to 5:1.
- 20 12. A tubular body, forming part of a device according to any one of claims 1 to 11.

Fig.1.

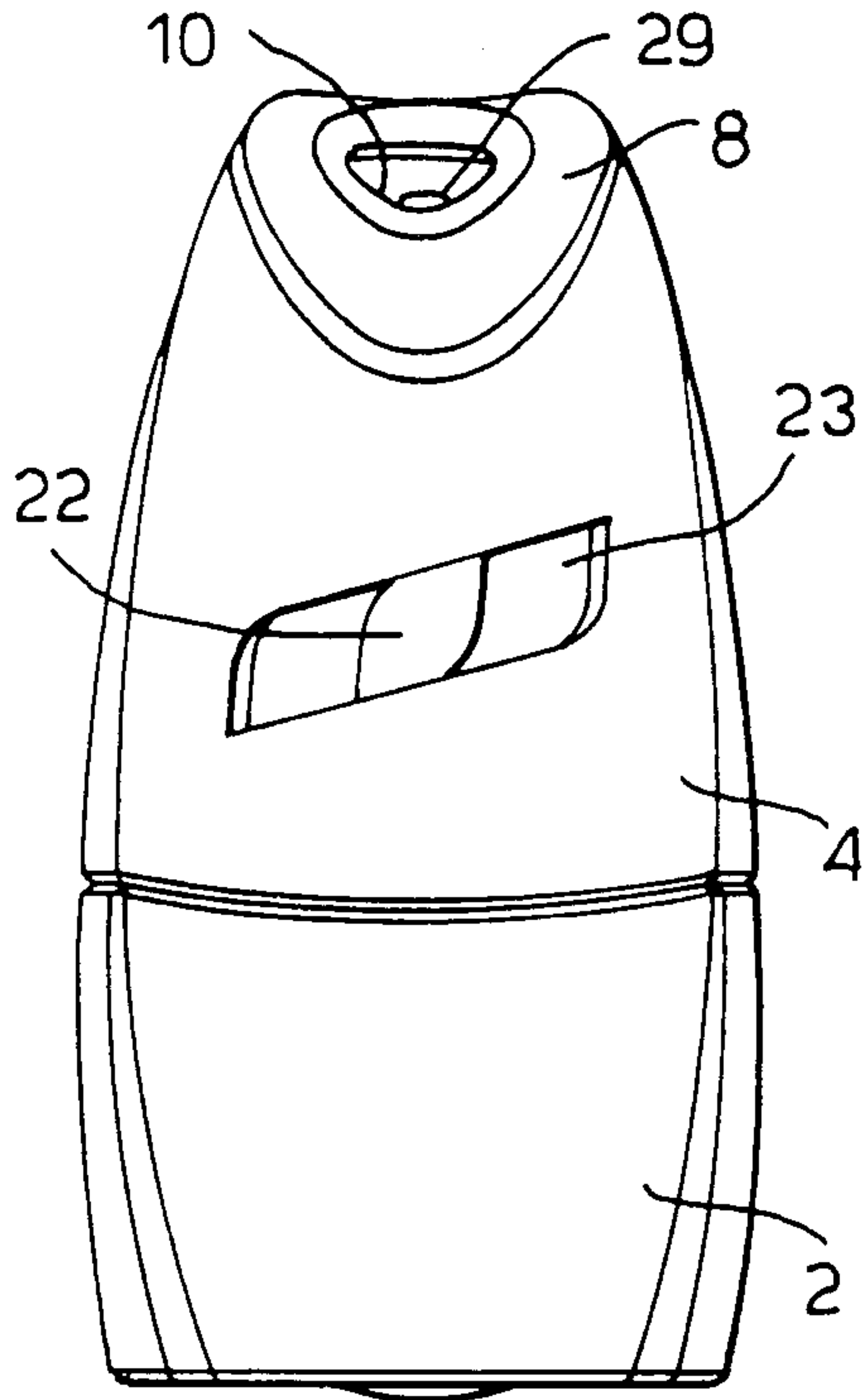

Fig.2.

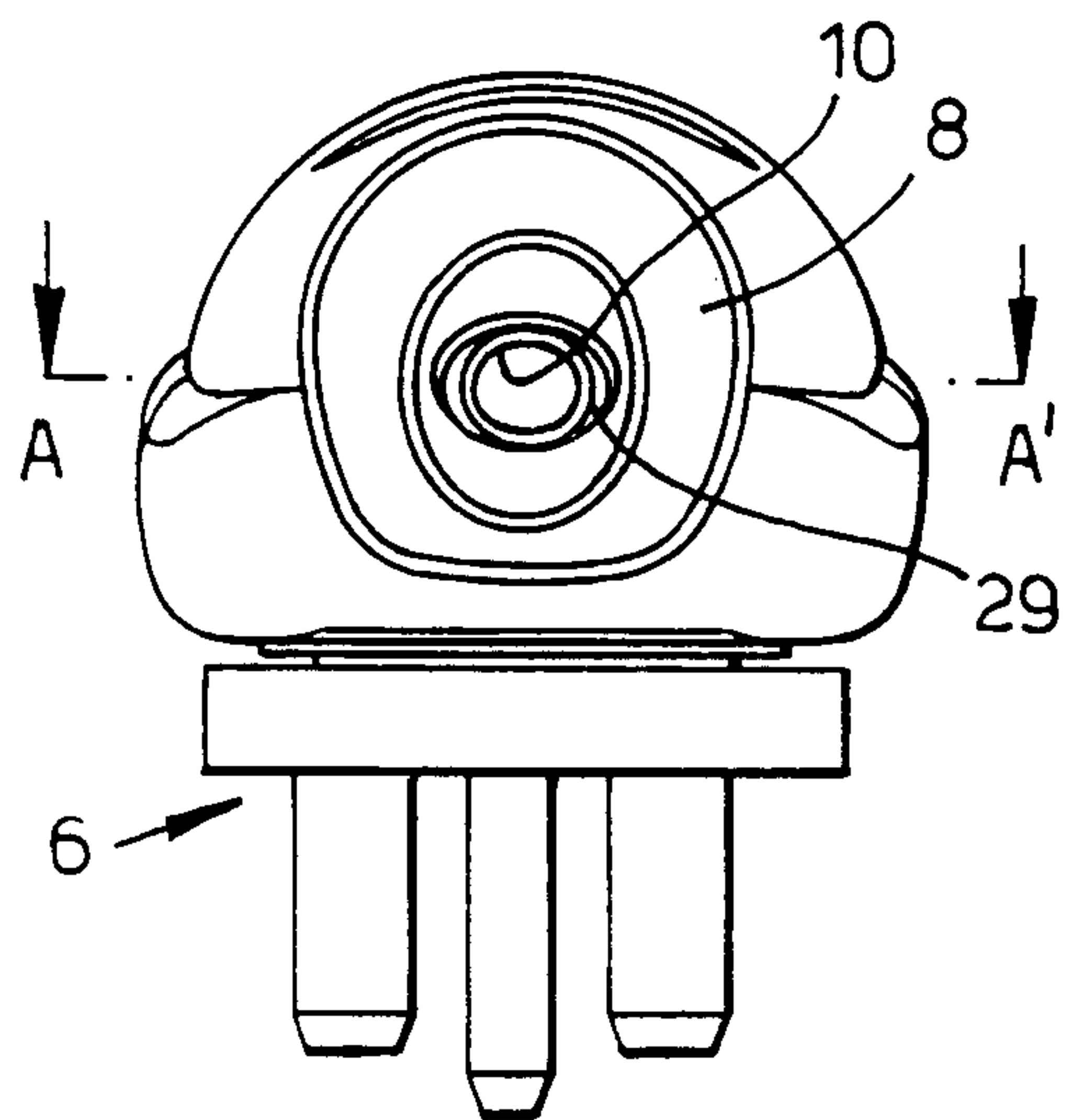
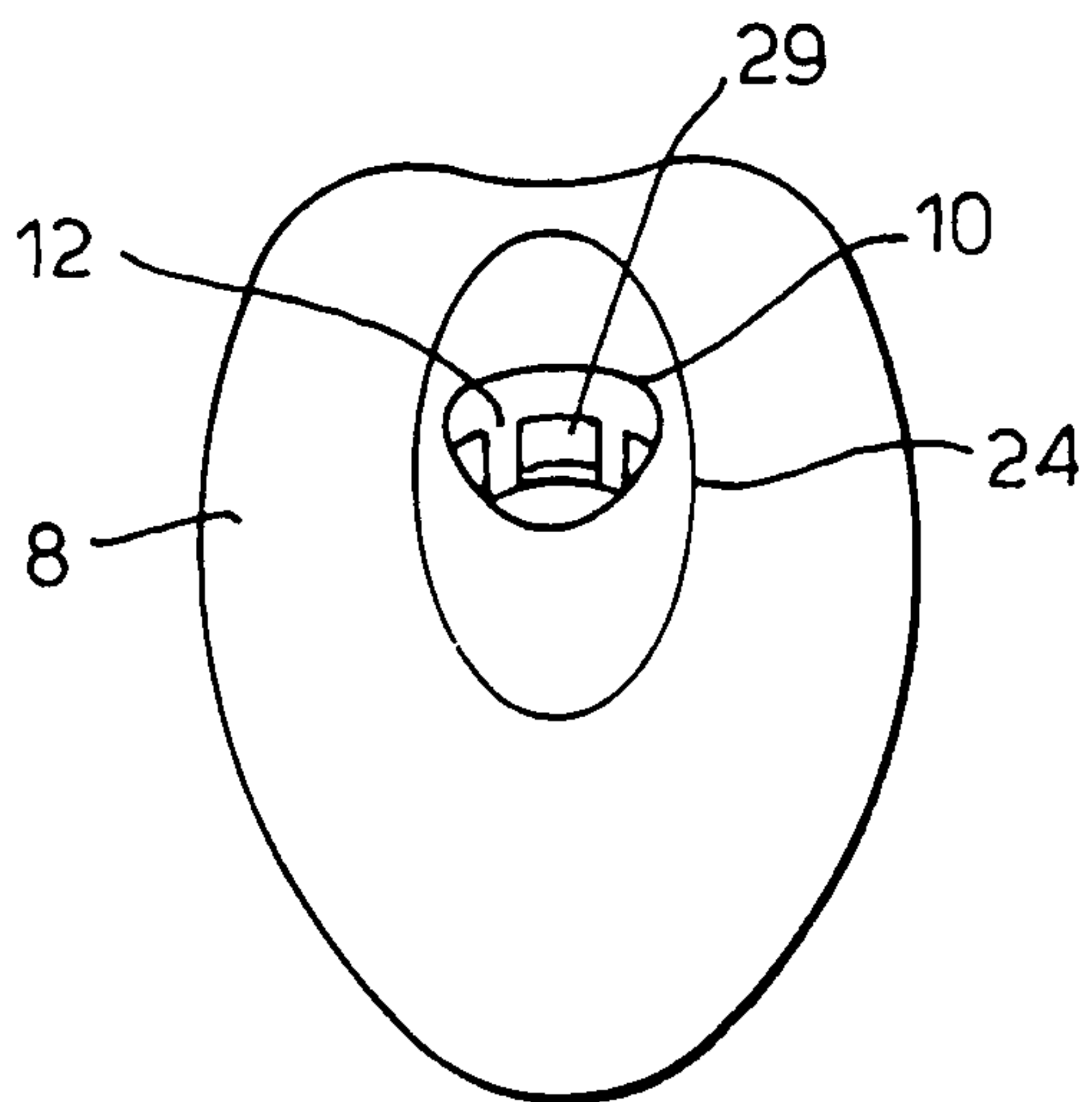

Fig.3.



2 / 3

Fig.4.

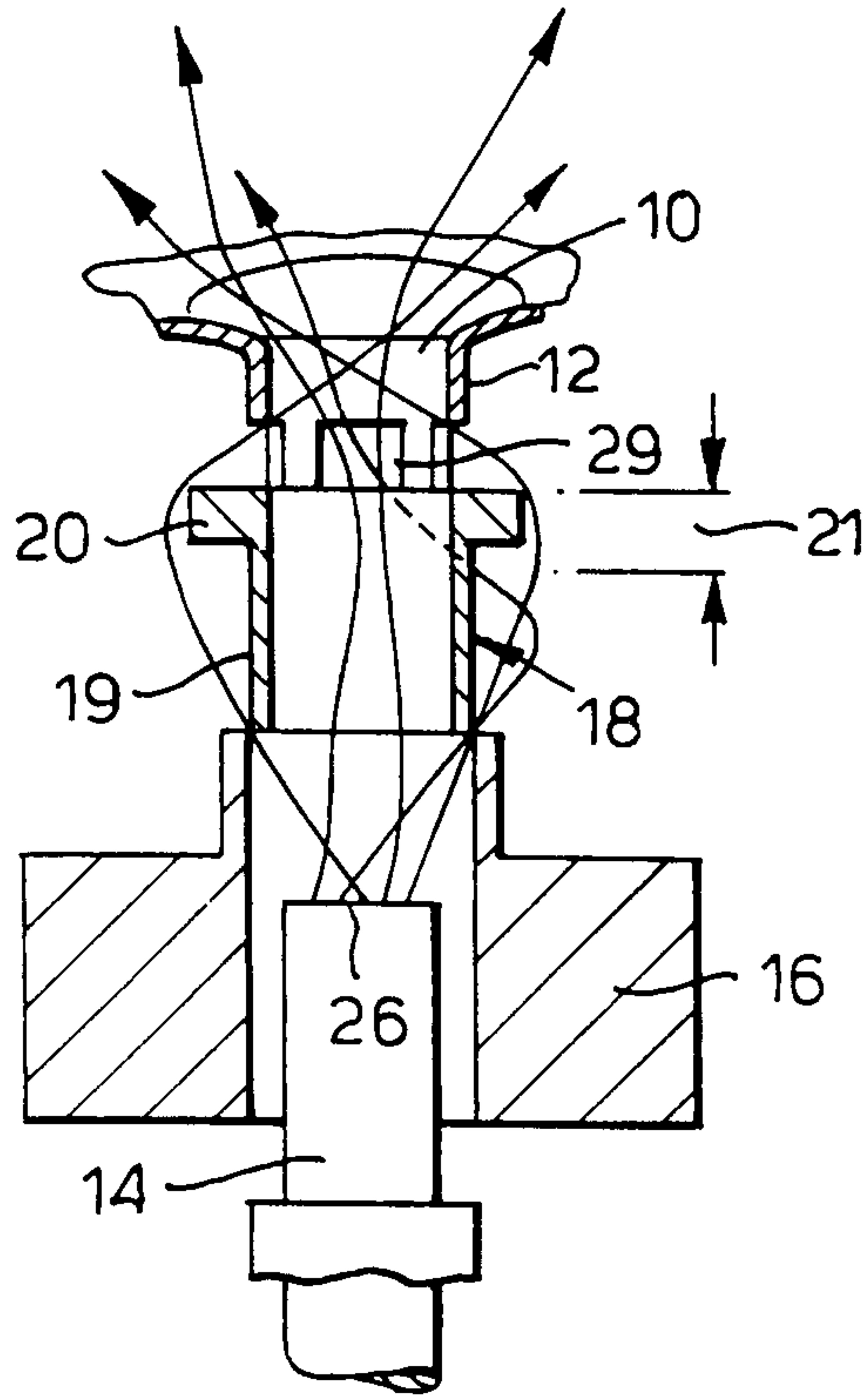

Fig.5.

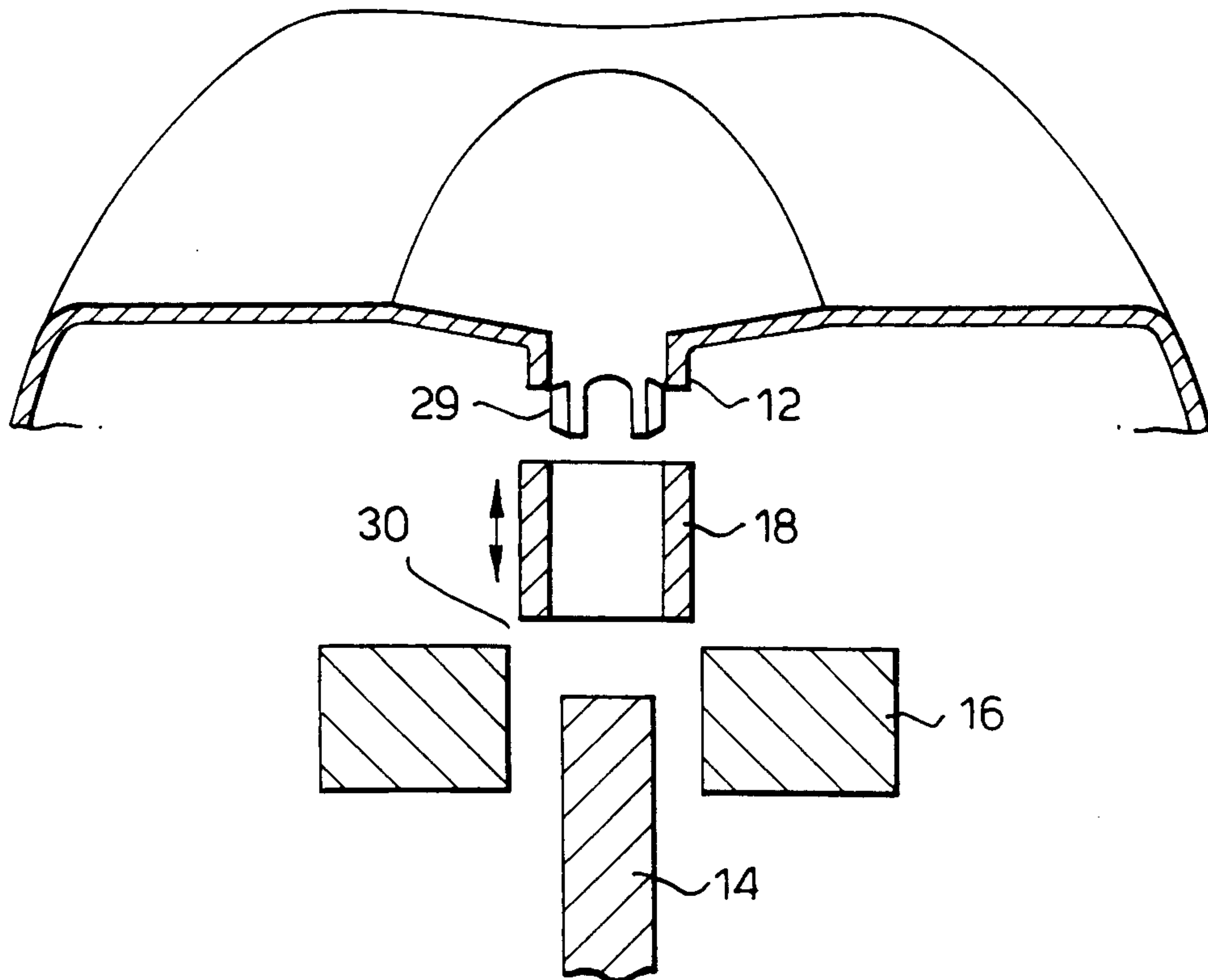

Fig.6.

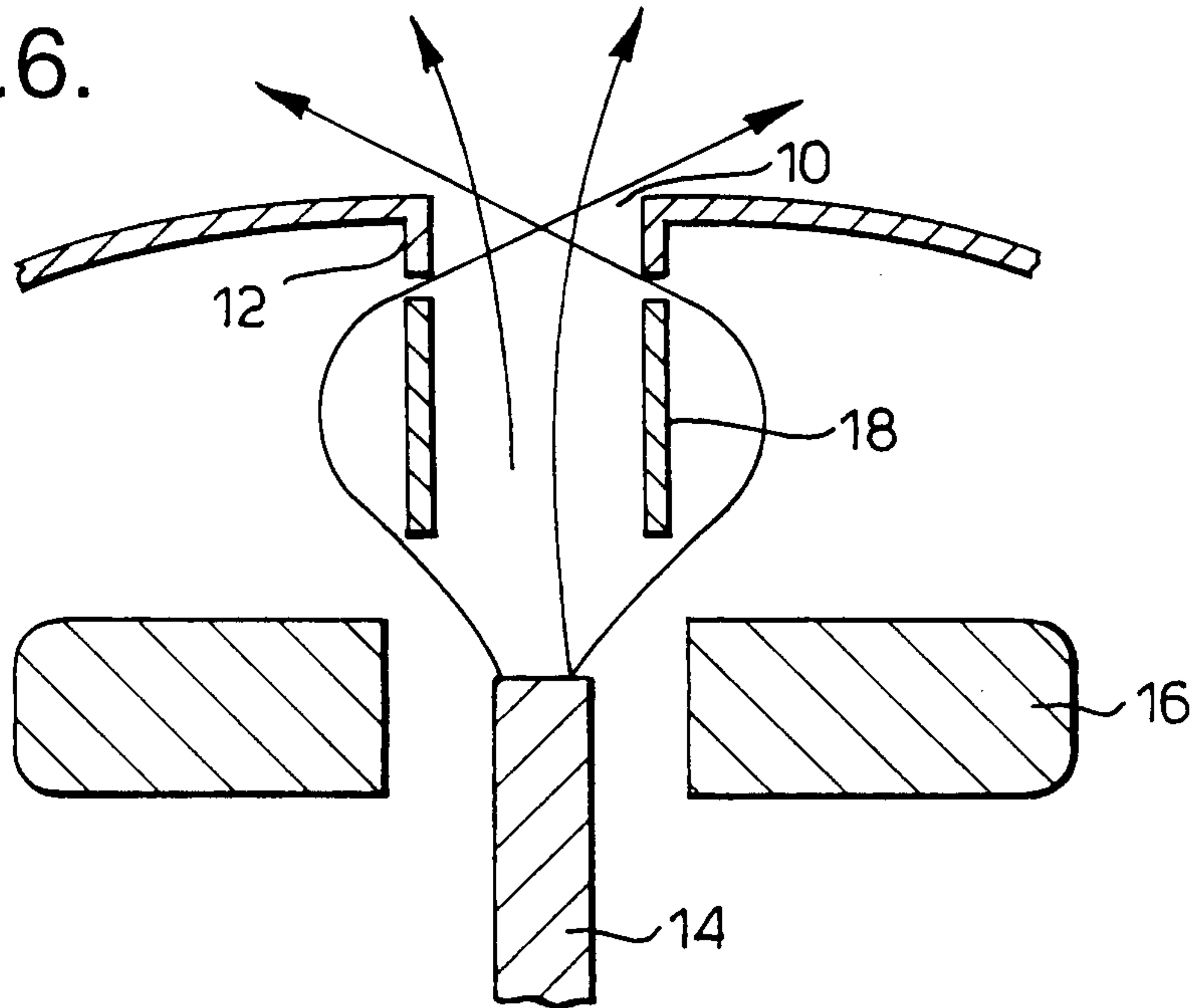

Fig.7.

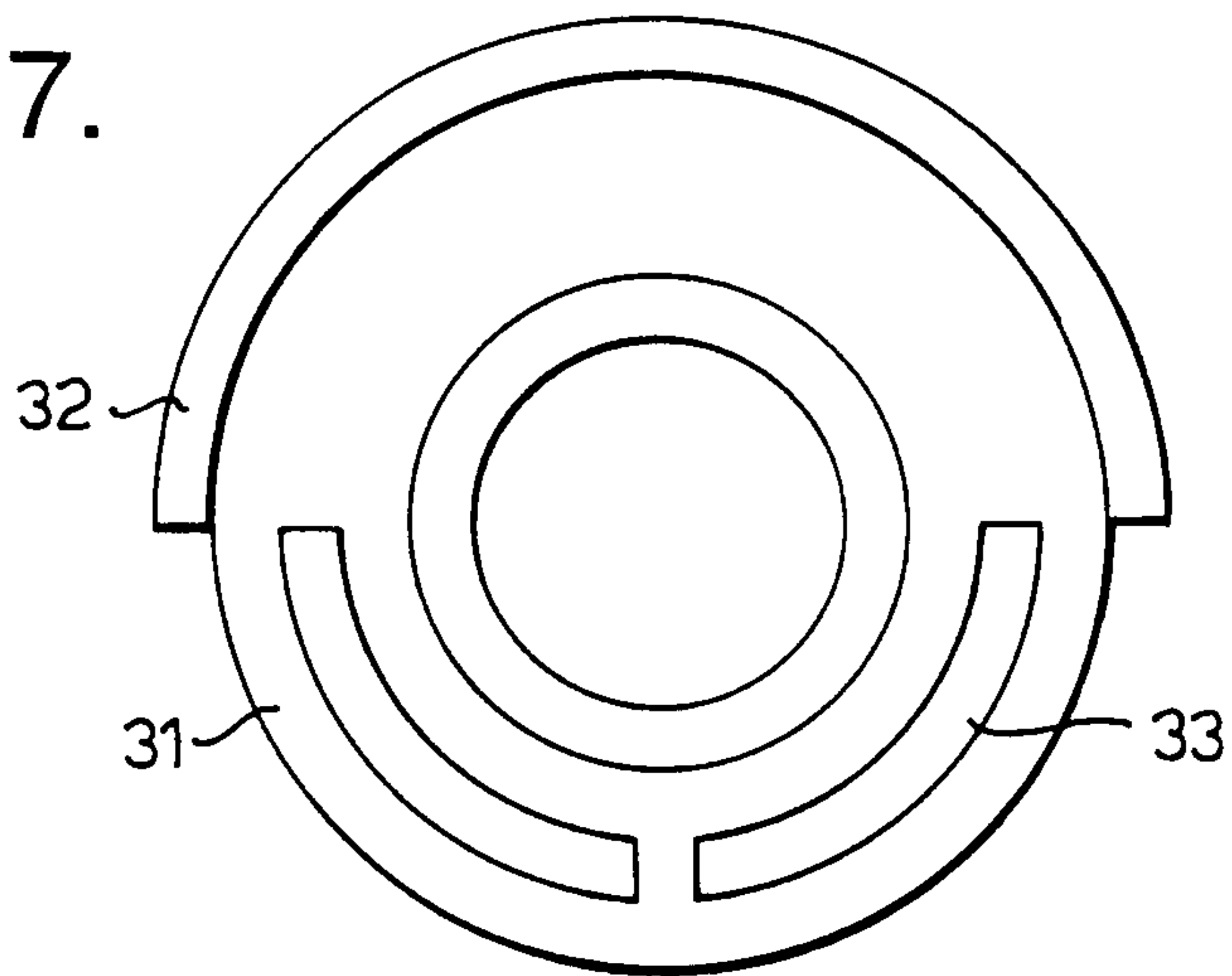

Fig.8.

