



(11) **EP 3 318 151 B1**

(12) **EUROPEAN PATENT SPECIFICATION**

(45) Date of publication and mention of the grant of the patent:  
**08.09.2021 Bulletin 2021/36**

(51) Int Cl.:  
**A43B 23/02** <sup>(2006.01)</sup> **A43B 23/04** <sup>(2006.01)</sup>  
**A43B 9/02** <sup>(2006.01)</sup>

(21) Application number: **17208011.1**

(22) Date of filing: **24.07.2014**

(54) **A KNITTED COMPONENT FOR AN ARTICLE FOR FOOTWEAR WITH INTEGRALLY KNIT CONTOURED PORTION**

GESTRICKTEN KOMPONENTE FÜR SCHUHWERK MIT EINEM VOLLSTÄNDIG EINGESTRICKTEN PROFILIERTEN TEIL

COMPOSANT TRICOTÉ POUR ARTICLE CHAUSSANT AVEC PARTIE PROFILÉE DE MAILLE INTÉGRÉE

(84) Designated Contracting States:  
**AL AT BE BG CH CY CZ DE DK EE ES FI FR GB GR HR HU IE IS IT LI LT LU LV MC MK MT NL NO PL PT RO RS SE SI SK SM TR**

(30) Priority: **13.09.2013 US 201314026589**

(43) Date of publication of application:  
**09.05.2018 Bulletin 2018/19**

(62) Document number(s) of the earlier application(s) in accordance with Art. 76 EPC:  
**14752957.2 / 3 043 670**

(73) Proprietor: **NIKE Innovate C.V.**  
**Beaverton, OR 97005-6453 (US)**

(72) Inventor: **PODHAJNY, Daniel A.**  
**Beaverton, OR 97005-6453 (US)**

(74) Representative: **Prinz & Partner mbB**  
**Patent- und Rechtsanwälte**  
**Rundfunkplatz 2**  
**80335 München (DE)**

(56) References cited:  
**WO-A1-2015/134114 US-A- 5 345 638**  
**US-B2- 8 522 577**

**EP 3 318 151 B1**

Note: Within nine months of the publication of the mention of the grant of the European patent in the European Patent Bulletin, any person may give notice to the European Patent Office of opposition to that patent, in accordance with the Implementing Regulations. Notice of opposition shall not be deemed to have been filed until the opposition fee has been paid. (Art. 99(1) European Patent Convention).

## Description

### FIELD

**[0001]** The present disclosure relates to an article of footwear and, more particularly, relates to an article of footwear incorporating a knitted component with an integrally knit contoured portion. The invention relates to a knitted component as in the appended claims.

### BACKGROUND

**[0002]** This section provides background information related to the present disclosure which is not necessarily prior art.

**[0003]** Conventional articles of footwear generally include two primary elements, an upper and a sole structure. The upper is secured to the sole structure and forms a void on the interior of the footwear for comfortably and securely receiving a foot. The sole structure is secured to a lower area of the upper, thereby being positioned between the upper and the ground. In athletic footwear, for example, the sole structure may include a midsole and an outsole. The midsole often includes a polymer foam material that attenuates ground reaction forces to lessen stresses upon the foot and leg during walking, running, and other ambulatory activities. Additionally, the midsole may include fluid-filled chambers, plates, moderators, or other elements that further attenuate forces, enhance stability, or influence the motions of the foot. The outsole is secured to a lower surface of the midsole and provides a ground-engaging portion of the sole structure formed from a durable and wear-resistant material, such as rubber. The sole structure may also include a sockliner positioned within the void and proximal a lower surface of the foot to enhance footwear comfort.

**[0004]** The upper generally extends over the instep and toe areas of the foot, along the medial and lateral sides of the foot and around the heel area of the foot. In some articles of footwear, such as basketball footwear and boots, the upper may extend upward and around the ankle to provide support or protection for the ankle. Access to the void on the interior of the upper is generally provided by an ankle opening in a heel region of the footwear. A lacing system is often incorporated into the upper to adjust the fit of the upper, thereby permitting entry and removal of the foot from the void within the upper. The lacing system also permits the wearer to modify certain dimensions of the upper, particularly girth, to accommodate feet with varying dimensions. In addition, the upper may include a tongue that extends under the lacing system to enhance adjustability of the footwear, and the upper may incorporate a heel counter to limit movement of the heel.

**[0005]** A variety of material elements (e.g., textiles, polymer foam, polymer sheets, leather, synthetic leather) are conventionally utilized in manufacturing the upper. In athletic footwear, for example, the upper may have

multiple layers that each includes a variety of joined material elements. As examples, the material elements may be selected to impart stretch-resistance, wear-resistance, flexibility, air-permeability, compressibility, comfort, and moisture-wicking to different areas of the upper. In order to impart the different properties to different areas of the upper, material elements are often cut to desired shapes and then joined together, usually with stitching or adhesive bonding. Moreover, the material elements are often joined in a layered configuration to impart multiple properties to the same areas. As the number and type of material elements incorporated into the upper increases, the time and expense associated with transporting, stocking, cutting, and joining the material elements may also increase. Waste material from cutting and stitching processes also accumulates to a greater degree as the number and type of material elements incorporated into the upper increases. Moreover, uppers with a greater number of material elements may be more difficult to recycle than uppers formed from fewer types and numbers of material elements. By decreasing the number of material elements utilized in the upper, therefore, waste may be decreased while increasing the manufacturing efficiency and recyclability of the upper.

**[0006]** US 5 345 638 A discloses a method which considers the production of a shoe upper by cutting out the shoe upper in the form of a layout from a web of material. Further, a shoe upper is shaped disclosing a connection of material parts of the layout with a formation of seams. A web of material is used to produce layouts by different production measures, such as different styles, yarn material, color, material thickness, single layer or multilayer type of material or the like, at the same time with the production of web of material, and with a sole part attached to the layout. The layout is cut from the web as a unit with the sole part and processed into a shoe part having an upper and sole part.

### SUMMARY

**[0007]** This section provides a general summary of the disclosure, and is not a comprehensive disclosure of its full scope or all of its features.

**[0008]** An article of footwear is disclosed that includes a sole structure and an upper that is coupled to the sole structure. The upper includes a medial side and a lateral side, and the upper includes a knitted component formed of unitary knit construction. The knitted component has a first edge and a second edge. The knitted component also includes a base portion configured to be disposed adjacent the sole structure and to be disposed under a foot. The knitted component further includes a heel portion, a forefoot portion, a medial portion, and a lateral portion that are each formed of unitary knit construction with the base portion. The knitted component additionally includes a collar with a rim, and the collar extends from the medial portion and/or the lateral portion. The second edge is joined to the first edge at a seam of the knitted

component causing the base portion, the heel portion, the forefoot portion, the medial portion, and the lateral portion to cooperatively define a void for receiving the foot. The seam has a first end and a second end, wherein the first end is located generally at the rim of the collar on one of the medial side and the lateral side of the upper. The second end is spaced from the first end.

**[0009]** Additionally, a knitted component configured to form an upper for an article of footwear is disclosed, wherein the upper is configured to be attached to a sole structure. The knitted component includes a base portion with a first side that is at least partially defined by a first edge of the knitted component. The base portion is configured to be disposed adjacent the sole structure. The knitted component also includes a heel portion and a forefoot portion that are formed of unitary knit construction with the base portion. Furthermore, the knitted component includes a medial portion and a lateral portion that extend from a second side of the base portion. The second side is opposite from the first side, and one of the medial portion and the lateral portion is at least partially defined by a second edge of the knitted component. The second edge is configured to be joined to the first edge at a seam to locate the one of the medial portion and the lateral portion adjacent the first side of the base portion and the other of the medial portion and the lateral portion adjacent the second side of the base portion. Moreover, the second edge is configured to be joined to the first edge such that the base portion, the heel portion, the forefoot portion, the medial portion, and the lateral portion cooperatively define a void that is configured to receive a foot. The knitted component further comprises a throat portion that is formed of unitary knit construction with the medial portion, the lateral portion and the forefoot portion.

**[0010]** Moreover, a method of manufacturing an article of footwear is disclosed. The method includes knitting a knitted component formed of unitary knit construction to have a base portion with a first side that is at least partially defined by a first edge of the knitted component, a heel portion and a forefoot portion that are formed of unitary knit construction with the base portion, and a medial portion and a lateral portion that extend from a second side of the base portion. The second side is opposite from the first side. One of the medial portion and the lateral portion is at least partially defined by a second edge of the knitted component. The method also includes moving the second edge toward the first edge to locate the one of the medial portion and the lateral portion adjacent the first side of the base portion and the other of the medial portion and the lateral portion adjacent the second side of the base portion. The method further includes joining the second edge to the first edge at a seam of the knitted component causing the base portion, the heel portion, the forefoot portion, the medial portion, and the lateral portion to cooperatively define a void that is configured to receive a foot. Moreover, the method includes forming an upper of the article of footwear from the knitted component. The

upper includes a medial side at least partially defined by the medial portion of the knitted component. The upper also includes a lateral side at least partially defined by the lateral portion of the knitted component.

**[0011]** Further areas of applicability will become apparent from the description provided herein. The description and specific examples in this summary are intended for purposes of illustration only and are not intended to limit the scope of the present disclosure.

## DRAWINGS

**[0012]** The drawings described herein are for illustrative purposes only of selected embodiments and not all possible implementations, and are not intended to limit the scope of the present disclosure.

FIG. 1 is a perspective view of an article of footwear which does not fall under the scope of the claimed invention;

FIG. 2 is a perspective view of the article of footwear of FIG. 1 with a closure member removed;

FIG. 3 is an exploded perspective view of the article of footwear of FIG. 2;

FIG. 4 is a perspective view of a knitted component with inlaid strands of the article of footwear of FIG. 1;

FIG. 5 is a top plan view of the knitted component of FIG. 4;

FIG. 6 is a bottom plan view of the knitted component of FIG. 4 with a footprint shown in phantom;

FIG. 7 is a section view of the knitted component taken along the line 7-7 of FIG. 6;

FIG. 8 a schematic view of a heel portion of the knitted component taken from the perspective of the line 8-8 of FIG. 5;

FIG. 9 is a detail view of a portion of the knitted component taken from FIG. 6;

FIGS. 10 and 11 are bottom plan views of the knitted component, wherein FIG. 10 shows the closure member in the unsecured position and FIG. 11 shows the closure member in the secured position;

FIG. 12 is a bottom view of a knitted component with inlaid strands according to additional embodiments of the present disclosure;

FIGS. 13 and 14 are schematic views of a unitary knit construction with inlaid strands;

FIGS. 15-23 are perspective schematic views of parts of a flat knitting machine shown during formation of a unitary knit construction with an inlaid strand;

FIG. 24 is a side view of an upper of an article of footwear that includes a knitted component according to embodiments of the invention;

FIG. 25 is a bottom view of the upper of FIG. 24;

FIG. 26 is a front view of the upper of FIG. 24;

FIG. 27 is a perspective view of the upper of FIG. 24;

FIG. 28 is a plan view of the knitted component of the upper of FIG. 24 showing the interior surface of the knitted component;

FIG. 29 is a plan view of the knitted component of the upper of FIG. 24 showing the exterior surface of the knitted component; and

FIGS. 30-32 are perspective views of the knitted component shown being assembled progressively into the upper of FIG. 24;

FIG. 33 is a perspective view of the upper of FIG. 24 with a sole structure being attached to form an article of footwear;

FIG. 34 is a perspective view of the upper of FIG. 24 attached to a sole structure to form the article of footwear according to exemplary embodiments;

FIG. 35 is a bottom view of an upper of an article of footwear that includes a knitted component according to additional embodiments of the invention;

FIG. 36 is a rear view of the upper of FIG. 35;

FIG. 37 is a plan view of the knitted component of the upper of FIG. 35; and

FIG. 38 is a bottom view of the upper of FIG. 35 with an attached sole structure.

**[0013]** Corresponding reference numerals indicate corresponding parts throughout the several views of the drawings.

#### **DETAILED DESCRIPTION**

**[0014]** Example embodiments will now be described more fully with reference to the accompanying drawings.

**[0015]** The following discussion and accompanying figures disclose a variety of concepts relating to knitted components and the manufacture of knitted components. Although the knitted components may be utilized in a variety of products, an article of footwear that incorporates one of the knitted components is disclosed as an example.

#### **General Discussion of Article of Footwear**

**[0016]** Referring initially to FIGS. 1-3, an article of footwear 100 is illustrated which does not fall under the scope of the claimed invention. The footwear 100 can generally include a sole structure 110 and an upper 120.

**[0017]** Sole structure 110 is secured to upper 120 and extends between the foot and the ground when footwear 100 is worn. The sole structure 110 can include a midsole 112 and an outsole 114 that are layered on each other. The midsole 112 can include a resiliently compressible material, fluid-filled bladders, and the like. As such, the midsole 112 can cushion the wearer's foot and attenuate impact and other forces when running, jumping, and the like. The outsole 114 can be secured to the midsole 112 and can include a wear resistant material, such as rubber and the like. The outsole 114 can also include tread and other traction-enhancing features.

**[0018]** Moreover, the upper 120 can define a void 122 that receives a foot of the wearer. Stated differently, the upper 120 can define an interior surface 121 that defines

the void 122, and the upper 120 can define an exterior surface 123 that faces in a direction opposite the interior surface 121. When the wearer's foot is received within the void 122, the upper 120 can at least partially enclose and encapsulate the wearer's foot.

**[0019]** Many conventional footwear uppers are formed from multiple material elements (e.g., textiles, polymer foam, polymer sheets, leather, synthetic leather) that are joined through stitching or bonding, for example. In contrast, at least a portion of upper 120 is formed from a knitted component 116 having a unitary knit construction. The outer boundaries of the knitted component 116 can be defined by a peripheral edge 199, which is shown in FIGS. 5 and 6. As will be discussed, knitted component 116 can define at least a portion of the void within upper 120. Also, the knitted component 116 can define at least a portion of the exterior surface 123 and/or the interior surface 121 of the upper 120.

**[0020]** In some embodiments, the knitted component 116 can define a majority of the upper 120. Decreasing the number of material elements used in forming the upper 120 may decrease waste, while also increasing the manufacturing efficiency and recyclability of the upper 120. As discussed in greater detail below, the knitted component 116 of the upper 120 of the present disclosure can decrease waste and increase manufacturing efficiency and recyclability. Additionally, the knitted component 116 of the upper 120 can incorporate smaller numbers of seams or other discontinuities, thereby enhancing the overall comfort of footwear 100.

**[0021]** The knitted component 116 may also have common properties when formed from the same strand, yarn (or type of yarn) or with similar knit structures. For example, using the same strand in various portions of the knitted component 116 can impart similar durability, strength, stretch, wear-resistance, biodegradability, thermal, and hydrophobic properties. In addition to physical properties, using the same strand in multiple portions of the knitted component 116 can impart common aesthetic or tactile properties, such as color, sheen, and texture. Using the same knit structures across different portions of the knitted component 116 may also impart common physical properties and aesthetic properties.

#### **Knitted Component Configurations**

**[0022]** FIGS. 4-6 illustrate various embodiments of knitted components 116 that may be incorporated into articles of footwear in a similar manner as the exemplary embodiment of FIGS. 1 through 3. The knitted component 116 illustrated in FIGS. 4-6 are depicted separate from a remainder of footwear 100. However, it should be understood that each of the embodiments of knitted component 116 described herein may be combined with the elements of footwear 100, described above, to form an article of footwear 100 incorporating the knitted component 116.

**[0023]** The knitted component 116 can be of "unitary

knit construction." As defined herein and as used in the claims, the term "unitary knit construction" means that the knitted component 116 is formed as a one-piece element through a knitting process. That is, the knitting process substantially forms the various features and structures of knitted component 116 without the need for significant additional manufacturing steps or processes. A unitary knit construction may be used to form a knitted component having structures or elements that include one or more courses of yarn or other knit material that are joined such that the structures or elements include at least one course in common (i.e., sharing a common strand or common yarn) and/or include courses that are substantially continuous between each portion of the knitted component 116. With this arrangement, a one-piece element of unitary knit construction is provided.

**[0024]** Although portions of knitted component 116 may be joined to each other following the knitting process, knitted component 116 remains formed of unitary knit construction because it is formed as a one-piece knit element. Moreover, knitted component 116 remains formed of unitary knit construction when other elements (e.g., an inlaid strand, a closure element, logos, trademarks, placards with care instructions and material information, and other structural elements) are added following the knitting process.

**[0025]** FIGS. 4-6 illustrate exemplary embodiments of the knitted component 116 as defining a majority of the upper 120 of the article of footwear 100. As shown, the knitted component 116 of the upper 120 can include a base portion 124 or strobil portion or underfoot portion. Also, the knitted component 116 can include one or more side portions 126. The base portion 124 can be configured to be disposed adjacent the sole structure 110. For instance, the base portion 124 can attach directly or indirectly to the sole structure 110 such that the base portion 124 lies over the sole structure 110. In additional embodiments, one or more parts of the base portion 124 (e.g., a periphery of the base portion 124) can attach to the sole structure 110 while other parts remain detached or decoupled. Also, the base portion 124 can be configured to extend underneath the wearer's foot. The side portion(s) 126 can extend from the base portion 124 and can be configured to at least partially cover over the wearer's foot. Also, the base portion 124 and side portion(s) 126 can cooperate to define a void 122 that receives the wearer's foot. Again, the base portion 124 and the side portion(s) 126 can be formed of a unitary knit construction as discussed above.

**[0026]** As shown in the illustrated embodiments, the side portions 126 of the knitted component 116 can include a heel portion 128, a lateral portion 130, a medial portion 132, a forefoot portion 134, and a tongue portion 136, each of which are formed of the same unitary knit construction as the base portion 124. Thus, the knitted component 116 can fit and conform closely to the wearer's foot. Also, because of this construction, the knitted component 116 can be formed relatively quickly to in-

crease manufacturing efficiency.

**[0027]** Also, as shown in FIG. 6 and as will be discussed in detail, the knitted component 116 can include one or more tensile strands 158 that are incorporated with the unitary knit construction of the knitted component 116. For instance, the strands 158 can be inlaid within the courses and/or wales of the knitted component 116 as will be discussed. Also, the strands 158 can be attached to the interior and/or exterior surface of the knitted component 116.

**[0028]** The strand(s) 158 can be disposed in the upper to extend across the sides and/or under the wearer's foot. Also, the strand(s) 158 can be operably coupled to a closure member 154, such as a shoelace 155. Thus, tensioning the shoelace 155 can, in turn, tension the strand(s) 158. As a result, the strand(s) 158 can provide support to the wearer's foot for increased comfort and better fit.

**[0029]** The illustrated embodiments of the upper 120 and the footwear 100 are configured to be worn on a left foot of the wearer. However, it will be appreciated that the footwear 100 can be configured to be worn on the right foot and can include similar features as the illustrated embodiments.

**[0030]** The footwear 100 can also be configured as a running shoe. However, the footwear 100 may also be applied to a variety of other athletic footwear types, including baseball shoes, basketball shoes, cycling shoes, football shoes, tennis shoes, soccer shoes, training shoes, walking shoes, and hiking boots, for example. The concepts may also be applied to footwear types that are generally considered to be non-athletic, including dress shoes, loafers, sandals, and work boots. Accordingly, the concepts disclosed with respect to footwear 100 apply to a wide variety of footwear types.

### Exemplary Features of Knitted Component

**[0031]** In exemplary embodiments schematically illustrated in FIG. 13, the primary element of knitted component 116 may be formed from at least one yarn 1138 or other strand that is manipulated (e.g., with a knitting machine) to form a plurality of intermeshed loops that define a variety of courses and wales. Although yarn 1138 forms each of the courses and wales in this configuration, additional yarns may form one or more of the courses and/or wales.

**[0032]** The properties that a particular type of yarn will impart to an area of a knitted component partially depend upon the materials that form the various filaments and fibers within the yarn. Cotton, for example, provides a soft hand, natural aesthetics, and biodegradability. Elastane and stretch polyester each provide substantial stretch and recovery, with stretch polyester also providing recyclability. Rayon provides high luster and moisture absorption. Wool also provides high moisture absorption, in addition to insulating properties and biodegradability. Nylon is a durable and abrasion-resistant material with

relatively high strength. Polyester is a hydrophobic material that also provides relatively high durability.

**[0033]** Additional examples of a suitable configuration for a portion of knitted component 116 is depicted in Figure 14. In this configuration, knitted component 116 includes yarn 1138 and another yarn 1139 (i.e., plural strands). Yarns 1138 and 1139 are plated and cooperatively form a plurality of intermeshed loops defining multiple horizontal courses and vertical wales. That is, yarns 1138 and 1139 run parallel to each other. An advantage of this configuration is that the properties of each of yarns 1138 and 1139 may be present in this area of knitted component 1130. For example, yarns 1138 and 1139 may have different colors, with the color of yarn 1138 being primarily present on a face of the various stitches in knit element 1131 and the color of yarn 1139 being primarily present on a reverse of the various stitches in knit element 1131. As another example, yarn 1139 may be formed from a yarn that is softer and more comfortable against the foot than yarn 1138, with yarn 1138 being primarily present on first surface 1136 and yarn 1139 being primarily present on second surface 1137.

**[0034]** Moreover, as shown in FIGS. 13 and 14, a strand 1132 can be incorporated in the unitary knit construction of the knitted component 116. The strand 1132 can be a tensile strand element that provides support to the knitted component 116. Stated differently, tension within the strand 1132 can allow the knitted component 116 to resist deformation, stretching, or otherwise provide support for the wearer's foot during running, jumping, or other movements of the wearer's foot. Also, it will be appreciated that the strand 158 of FIG. 6 (mentioned above and described in detail below) can be incorporated in the knitted component 116 similar to the strand 1132 of FIGS. 13 and 14.

**[0035]** As will be discussed, the strand 1132 can be incorporated or inlaid into the unitary knit construction of the knitted component 116 such that the strand 1132 can be incorporated during the knitting processes on the knitting machine. For instance, the strand 1132 can be inlaid within the unitary knit construction such that the strand 1132 extends along one of the courses as shown in FIGS. 13 and 14 and/or the wales of the knitted component 116. As shown in FIGS. 13 and 14, the strand 1132 can alternate between being located (a) behind loops formed from yarn 1138 and (b) in front of loops formed from yarn 1138. In effect, inlaid strand 1132 weaves through the unitary knit construction of knit element 1131.

**[0036]** The knitted component may also include one or more strands or yarns that are formed from at least one of a thermoset polymer material and natural fibers (e.g., cotton, wool, silk). Other yarns or strands may be formed from a thermoplastic polymer material. In general, a thermoplastic polymer material melts when heated and returns to a solid state when cooled. More particularly, the thermoplastic polymer material transitions from a solid state to a softened or liquid state when subjected to sufficient heat, and then the thermoplastic polymer material

transitions from the softened or liquid state to the solid state when sufficiently cooled. As such, thermoplastic polymer materials are often used to join two objects or elements together. In this case, yarn may be utilized to join (a) one portion of yarn to another portion of yarn, (b) yarn and inlaid strand to each other, or (c) another element (e.g., logos, trademarks, and placards with care instructions and material information) to knitted component, for example. As such, yarn may be considered a fusible yarn given that it may be used to fuse or otherwise join portions of knitted component to each other. Moreover, yarn may be considered a non-fusible yarn given that it is not formed from materials that are generally capable of fusing or otherwise joining portions of knitted component to each other. That is, yarn may be a non-fusible yarn, whereas other yarn(s) may be a fusible yarn. In some configurations of knitted component, yarn (i.e., the non-fusible yarn) may be substantially formed from a thermoset polyester material and yarn (i.e., the fusible yarn) may be at least partially formed from a thermoplastic polyester material.

**[0037]** The use of plated yarns may impart advantages to knitted component. When yarn is heated and fused to yarn and inlaid strand, this process may have the effect of stiffening or rigidifying the structure of knitted component. Moreover, joining (a) one portion of yarn to another portion of yarn or (b) yarn and inlaid strand to each other has the effect of securing or locking the relative positions of yarn and inlaid strand, thereby imparting stretch-resistance and stiffness. That is, portions of yarn may not slide relative to each other when fused with yarn, thereby preventing warping or permanent stretching of knit element due to relative movement of the knit structure. Another benefit relates to limiting unraveling if a portion of knitted component becomes damaged or one of yarns is severed. Accordingly, areas of knitted component may benefit from the use of both fusible and non-fusible yarns within knit element.

**[0038]** Additionally, it will be appreciated that the knitted component can have varying zones that collectively form the unitary knit construction. For instance, the knitted component can include a combination at least two of the following: a flat knit zone, a tubular knit zone, a 1x1 mesh knit zone, a 2x2 mesh knit zone, a 3x2 mesh knit zone, a 1x1 mock mesh knit zone, a 2x2 mock mesh knit zone, a 2x2 hybrid knit zone, a full gauge knit zone, a ½ gauge knit zones, and the like. Accordingly, the knitted component 116 and upper 120 can be constructed according to the teachings of U.S. Patent Publication No. 2012/0233882, which published on September 20, 2012, and which is hereby incorporated by reference in its entirety.

### Embodiments of Upper and Knitted Component

**[0039]** Various embodiments of the upper 120 and knitted component 116 will now be discussed in greater detail. As shown, the upper 120 can define a longitudinal

direction 125, a transverse direction 127, and a vertical direction 129, which will be used for referencing different features of the upper 120 in the below discussion.

**[0040]** As mentioned above, the knitted component 116 of the upper 120 can include a base portion 124, which is configured to be disposed underneath the wearer's foot. An outline of the wearer's foot is shown in FIG. 6, such that the base portion 124 is at least generally defined relative to the wearer's foot. Thus, the base portion 124 can extend continuously underneath one or more portions of the heel, the sole, the toes, the arch, and/or other inferior surfaces of the wearer's foot. In additional embodiments, the base portion 124 can include openings and so as to extend partially or discontinuously under the wearer's foot

**[0041]** The knitted component 116 can also include various side portions 126 that extend peripherally from the base portion 124. The side portions 126 can be configured to cover over and lie against at least a portion of the wearer's foot. In the embodiments illustrated, the side portions 126 of the knitted component 116 can substantially encompass the base portion 124. Also, it will be appreciated that the base portion 124 and the side portions 126 can collectively define the interior surface 121 of the knitted component 116 as well as the exterior surface 123 of the knitted component 116.

**[0042]** For instance, the side portions 126 can include a heel portion 128, which is disposed on one end of the base portion 124. The heel portion 128 can also extend upwards from the base portion 124 in the vertical direction 129 as shown in FIG. 4. The heel portion 128 can be configured to cover over a heel and/or an ankle area of the wearer's foot.

**[0043]** The side portions 126 of the knitted component 116 can also include a lateral portion 130, which is disposed forward relative to the heel portion 128, and which can extend upwards from a lateral side of the base portion 124 as shown in FIG. 4. The lateral portion 130 can be configured to cover over and lie against a lateral area of the wearer's foot.

**[0044]** Furthermore, the side portions 126 of the knitted component 116 can include a medial portion 132, which is disposed on an opposite side of the base portion 124 relative to the lateral portion 130 and forward of the heel portion 128. The medial portion 132 can further extend upwards in the vertical direction 129 from the base portion 124 as shown in FIG. 4. The medial portion 132 can be disposed on an opposite side of the base portion 124 in the transverse direction 127. The medial portion 132 can be configured to cover over and lie against a medial area or instep of the wearer's foot.

**[0045]** The heel portion 128, lateral portion 130, and medial portion 132 can collectively define a horseshoe-shaped collar 133 of the upper 120. The collar 133 can provide access into and out of the void 122 of the upper 120. Moreover, a lateral edge 135 of the lateral portion 130 and a medial edge 137 of the medial portion 132 can collectively define a throat 131 of the upper 120. The

throat 131 can extend substantially parallel to the longitudinal direction 125, or the throat 131 can be disposed at an angle relative to the longitudinal direction 125. Also, although the throat 131 is substantially centered over the base portion 124 in the embodiments of FIG. 4, the throat 131 can be disposed to one side relative to the base portion 124 in the transverse direction 127. As will be discussed, the width of the throat 131 can be selectively varied by the closure member 154 so as to move the lateral and medial edges 135, 137 toward and away from each other. As a result, the footwear 100 can be selectively tightened on the wearer's foot and loosened from the wearer's foot.

**[0046]** Additionally, the side portions 126 of the knitted component 116 can include a forefoot portion 134. The forefoot portion 134 can be disposed on an opposite end of the base portion 124 relative to the heel portion 128 and forward of the lateral and medial portions 130, 132 in the longitudinal direction 125 as shown in FIG. 1. Also, the forefoot portion 134 can be integrally connected to either the lateral portion 130 or the medial portion 132, and the forefoot portion 134 can be spaced from the other. In the embodiments shown, for instance, the forefoot portion 134 is integrally connected to the lateral portion 130 and is spaced from the medial portion 132. Accordingly, when the upper 120 is in a disassembled state as shown in FIG. 4, a gap 139 can be defined between the forefoot portion 134 and the medial portion 132.

**[0047]** Still further, the side portions 126 of the knitted component 116 can include a tongue portion 136. As shown in FIG. 4, the tongue portion 136 can include a curved region 143 and a longitudinal region 145. When the upper 120 is disassembled as shown in FIG. 4, the tongue portion 136 can extend generally forward from the base portion 124, and the curved region 143 can be disposed within the gap 139 between the medial and forefoot portions. The curved region 143 can also curve such that the longitudinal region 145 extends generally rearwardly and at an angle 143 relative to the medial portion 132 as shown in FIG. 4. The curvature of the curved region 143 can be achieved by having knit courses that substantially radiate from a common area 151 as shown in FIG. 5. The common area 151 can be an imaginary point that is spaced from the periphery of the curved region 143, between the tongue portion 136 and the medial portion 132 as shown, or the common area 151 can be disposed elsewhere. Also, when the upper 120 is assembled, the curved region 143 can wrap upwards to at least partially fill the gap 139, and the longitudinal region 145 of the tongue portion 136 can be disposed within the throat 131 of the upper to cover over the wearer's foot between the lateral portion 130 and the medial portion 132. Moreover, when the upper 120 is assembled, the longitudinal region 145 of the tongue portion 136 can be detached and decoupled from the lateral and/or medial portions 130, 132 as shown in FIG. 3.

**[0048]** As shown in FIGS. 4, 5, and 6, the base portion 124 and the heel portion 128 can define a heel cavity 148

that is configured to receive a heel of the wearer's foot (see FIG. 6). The heel cavity 148 can have interior and/or exterior surfaces with three dimensional curvature. Also, the heel cavity 148 can have a convex outer surface. Thus, as the heel portion 128 extends in the vertical direction 129 from the base portion 124, the heel portion 128 can curve forward slightly in the longitudinal direction 125. Also, as the heel portion 128 extends in the transverse direction 127, both sides of the heel portion 128 can curve forward in the longitudinal direction 125 to join to the lateral and medial portions 130, 132. Accordingly, the heel cavity 148 can conform and approximately correspond to the shape of the wearer's heel and ankle.

**[0049]** Furthermore, as shown in FIGS. 4, 5, and 6, the base portion 124 and the forefoot portion 134 can define a forefoot cavity 150 that is configured to receive the toes and other forefoot regions of the wearer's foot (see FIG. 6). The forefoot cavity 150 can have interior and/or exterior surfaces with three dimensional curvature. Also, the forefoot cavity 150 can have a convex outer surface. Thus, as the forefoot portion 134 extends in the vertical direction 129 from the base portion 124, the forefoot portion 134 can curve rearwardly in the longitudinal direction 125. Also, as the forefoot portion 134 extends in the transverse direction 127, the forefoot portion 134 can curve rearwardly in the longitudinal direction 125 to join to the lateral portion 130.

**[0050]** The three dimensional curvature of the heel cavity 148 and/or the forefoot cavity 150 can be formed due to the unitary knit construction of the knitted component 116. For instance, as shown in FIG. 8, the heel portion 128 can include at least two tapered areas 170, 171. The tapered areas 170, 171 can have boundaries 173 that taper generally in the transverse direction 127 as indicated by broken lines. The tapered areas 170, 171 each have a plurality of courses, or row of stitches; however, the successive courses can have different lengths to thereby provide the tapered shape of the boundaries 173. Thus, the tapered areas 170, 171 can have an eye shape, a double pointed oval shape, a biconvex shape, or a crescent shape.

**[0051]** Also, the boundary 173 of the tapered area 170 is joined to the boundary 173 of the tapered area 171 in the unitary knit construction to provide the knitted component 116 with three dimensional curvature. This can produce a visually evident distortion along the joined boundaries 173. The distortion can be a so-called fully fashioned mark extending along the joined boundaries 173 in the knitted component 116.

**[0052]** In the embodiments of FIG. 8, there are a plurality of tapered areas that are joined along respective boundaries such that the tapered areas extend from the collar 133 to the base portion 124 and a majority of the heel portion 128 includes these tapered areas. Accordingly, a majority of the heel portion 128 can have three-dimensional curvature. However, it will be appreciated that knitted component 116 can include any number of tapered areas 170, 171 on any portion of the knitted com-

ponent 116 to provide three dimensional curvature to the knitted component 116. Also, the tapered areas 170, 171 can be oriented in any suitable direction on the knitted component 116. For instance, the forefoot portion 134 can similarly include tapered areas; however, such tapered areas can taper in the vertical direction 129 in exemplary embodiments.

**[0053]** The curved region 143 of the tongue portion 136 can also include a plurality of tapered areas that provide the curved region 143 with curvature. For instance, the curved region 143 can include tapered areas 193, 195 that are integrally knit together and joined along boundaries 197. This can produce a visually evident distortion along the joined boundaries 197. The distortion can be a so-called fully fashioned mark extending along the joined boundaries 197 in the knitted component 116. Additionally, as mentioned above, the courses within the curved region 143 can radiate from common area 151 to provide two-dimensional curvature.

**[0054]** Also, in some embodiments, the forefoot portion 134 can include a plurality of openings 152 that are arranged to assist with increasing curvature of the forefoot portion 134. In the embodiments illustrated, the plurality of openings 152 can include one or more rows of through-holes. Because the openings 152 reduce the amount of knitted material at those areas of the forefoot portion 134, the forefoot portion 134 can readily curve rearward toward the heel portion 128.

**[0055]** The knitted component 116 can additionally include at least two edge portions 140, 142 that are configured to be joined together when assembling the upper 120. It will be appreciated that the first edge portion 140 can be a first longitudinal section of larger peripheral edge 199 of the knitted component 116 shown in FIGS. 5 and 6. It will also be appreciated that the second edge portion 142 can be a second longitudinal section of the peripheral edge 199. The edge portions 140, 142 can be defined in any suitable location long the peripheral edge 199 and/or anywhere on the knitted component 116. As shown in FIGS. 5 and 6, the first edge portion 140 can extend along the curved region 143 of the tongue portion 136 and can also extend partially through the base portion 124 in the transverse direction 127, adjacent the forefoot portion 134. The second edge portion 142 can curve along the forefoot portion 134, generally in the transverse direction 127 and can extend downward in the vertical direction 129 along the forefoot portion 134 so as to partially define the gap 139. The first edge 140 and the second edge 142 can also meet at a notch 141 defined within the base portion 124 as shown in FIG. 4.

**[0056]** As mentioned above, the footwear 100 can further include a closure member 154, which is illustrated in FIG. 1. The closure member 154 can selectively secure the upper 120 to the wearer's foot and selectively release the upper 120 from the wearer's foot.

**[0057]** As shown in FIG. 1, the closure member 154 can be a shoelace 155. As such, the lateral portion 130 can include one or more lateral closure openings 156,

such as through-holes that are disposed in a row extending along the lateral edge 135. The medial portion 132 can include similar medial closure openings 157 that are disposed in a row extending along the medial edge 137. The openings 156, 157 can receive the shoelace 155 such that the shoelace 155 can criss-cross, zigzag, and alternate between the lateral and medial portions 130, 132.

**[0058]** It will be appreciated that the openings 156, 157 could be configured differently from the through-holes shown in FIG. 1. For instance, the openings 156, 157 could be defined by hoops, grommets, hooks, and other suitable features that are configured to receive a closure member and that are either integrated into the knitted component 116 or are removably attached to the knitted component 116.

**[0059]** Also, it will be appreciated that the closure member 154 could include structure other than the shoelace 155 without departing from the scope of the present disclosure. For instance, the closure member 154 could be a strap, a buckle, pile tape, or other suitable closure member.

**[0060]** Still further, as shown in FIG. 6, the upper 120 can include at least one tensile strand 158 that is coupled to the base portion 124 and/or the side portions 126. The strand 158 can be coupled to any portion of the base portion 124 and/or the side portion 126. Additionally, the strand 158 can be coupled to the base portion 124 and/or the side portion 126 in any suitable fashion. For instance, the strand 158 can be inlaid within courses and/or wales of the unitary knit construction of the base portion 124 and side portions 126 as will be discussed. Thus, the strand 153 can correspond to the strand 1132 described above and shown in FIGS. 13 and 14. The strand 158 can also be adhered, fastened, pierced through, or otherwise coupled to the interior or exterior surfaces 121, 123 of the base portion 124 and/or the side portion 126.

**[0061]** The strand 158, knitted component 116, and upper 120 can incorporate the teachings of one or more of commonly-owned U.S. Patent Application Serial Number 12/338,726 to Dua et al., entitled "Article of Footwear Having An Upper Incorporating A Knitted Component", filed on December 18, 2008 and published as U.S. Patent Application Publication Number 2010/0154256 on June 24, 2010, and U.S. Patent Application Serial Number 13/048,514 to Huffa et al., entitled "Article Of Footwear Incorporating A Knitted Component", filed on March 15, 2011 and published as U.S. Patent Application Publication Number 2012/0233882 on September 20, 2012, both of which applications are hereby incorporated by reference in their entirety (collectively referred to herein as the "Inlaid Strand cases").

**[0062]** The strand 158 can be an elongate and flexible. Also, the strand 158 can include at least one yarn, cable, wire, string, cord, filament, fiber, thread, rope, and the like. Also, the strand 158 can be formed from rayon, nylon, polyester, polyacrylic, silk, cotton, carbon, glass, aramids (e.g., para-aramid fibers and meta-aramid fibers),

ultra high molecular weight polyethylene, liquid crystal polymer, copper, aluminum, steel, or other suitable material. An individual filament utilized in the strand 158 may be formed from a single material (i.e., a monocomponent filament) or from multiple materials (i.e., a bicomponent filament). Similarly, different filaments may be formed from different materials. As an example, yarns utilized as strand 158 may include filaments that are each formed from a common material, may include filaments that are each formed from two or more different materials, or may include filaments that are each formed from two or more different materials. Similar concepts also apply to threads, cables, ropes, etc. The thickness (diameter) of strand 158 can be within a range from approximately 0.03 millimeters to 5 millimeters, for example. Also, the strand 158 can have a substantially circular cross section, an ovate cross section, or a cross section of any other suitable shape.

**[0063]** As an example, the strand 158 may be formed from a bonded nylon 6.6 with a breaking or tensile strength of 3.1 kilograms and a weight of 45 tex. The strand 158 can also be formed from a bonded nylon 6.6 with a breaking or tensile strength of 6.2 kilograms and a tex of 45. As a further example, the strand 158 may have an outer sheath that sheathes and protects an inner core.

**[0064]** In some embodiments, the strand 158 can have a fixed length (e.g., can be nonextendible). Also in some embodiments, the strand 158 can be resiliently extendible.

**[0065]** Additionally, in some embodiments, the strand 158 can include a thermoplastic material that is configured to adhere, bond, or fuse to the base portion 124 and/or the side portions 126 of the upper 120. For instance, selective application of heat can cause materials in the strand 158 to fuse to the materials of the base portion 124 and/or the side portions 126. The strand 158 can, thus, be included according to the teachings of U.S. Patent Publication No. 2012/0233882, which published on September 20, 2012.

**[0066]** As shown in the embodiments of FIG. 6, the upper 120 can include a single strand 158 that extends continuously between the medial portion 132, the base portion 124, and the lateral portion 130. Also, the strand 158 can include one or more turns 159, 160. The turns 159, 160 can be one hundred eighty degree turns or greater. Specifically, the strand 158 can include a plurality of lateral turns 159 that are arranged in a row along the lateral edge 135, and the strand 158 can include a plurality of medial turns that are arranged in a row along the medial edge 137. The strand 158 can also extend linearly between pairs of the turns 159, 160. Additionally, the strand 158 can include a first terminal end 164 that is disposed adjacent the heel portion 128, and the strand 158 can include a second terminal end 166 that is disposed adjacent the forefoot portion 134. The strand 158 can also alternately extend and zigzag between the lateral and medial portions 130, 132.

**[0067]** Furthermore, as shown in FIGS. 6 and 7, the knitted component 116 can define a passage 162 between the interior surface 121 and the exterior surface 123. The passage 162 can be defined in any suitable fashion. For instance, in embodiments in which the strand 158 is inlaid within the knitted component 116, the passage 162 can be defined through one or more courses or wales of the knitted component 116. Also, in some embodiments, the interior surface 121 can be defined by a layer of knitted material and the exterior surface 123 can be defined by a separate layer of knitted material, and a plurality of strands, filaments, or monofilaments can extend and provide spacing between these layers (e.g., a so-called "spacer knit material"). In these embodiments, the passage 162 can be defined between the layers of knitted material and among the plurality of spacer strands. In additional embodiments, the interior surface 121 and the exterior surface 123 can be interconnected stitched surfaces, and the passage 162 can be defined between these surfaces.

**[0068]** The passage 162 can extend across any portion of the upper 120. For instance, as indicated by broken lines in FIG. 6, the upper 120 can define a plurality of passages 162, and each passage 162 can extend continuously between the lateral portion 130, the base portion 124, and the medial portion 132. In the embodiments shown, each passage 162 extends partially across the lateral portion 130 (lateral passage), partially across the base portion 124 (base portion passage), and partially across the medial portion 132 (medial passage) such that the passage 162 is continuous between the lateral portion 130, the base portion 124, and the medial portion 132. However, it will be appreciated that one or more passage 162 can be localized and isolated on any portion of the upper 120.

**[0069]** As shown in FIG. 7, the strand 158 can be received and can extend longitudinally within one or more of the passages 162 so as to extend between the lateral portion 130, the base portion 124, and the medial portion 132. Also, the turns 159, 160 of the strand 158 can be exposed from the passages 162.

**[0070]** The lateral turns 159 can extend at least partially around respective ones of the lateral closure openings 156, and the medial turns 160 can extend at least partially around respective ones of the medial closure openings 157. Furthermore, as shown in FIG. 1, the shoelace 155 can be received within respective pairs of the lateral closure openings 156 and the lateral turns 159, and the shoelace 155 can also be received within respective pairs of the medial closure openings 157 and the medial turns 160. Stated differently, each pairing of lateral turn 159 and lateral closure opening 156 can cooperatively receive and support the shoelace 155, and each pairing of medial turn 160 and medial closure opening 157 can also receive and support the shoelace 155.

**[0071]** In some embodiments, the strand 158 can be loosely and moveably received within the respective passages 162. For instance, the strand 158 can slide longi-

tudinally through the passages 162. Thus, as shown in FIG. 9, the turns 159, 160 can be pulled closer to the respective closure opening 156, 157. In additional embodiments, the first and/or the second terminal end 164, 166 of the strand 158 can be fixed (e.g., fused) to the base portion 124 while remaining portions of the strand 158 can remain moveable relative to the base, lateral, and medial portions 124, 130, 132. In still additional embodiments, portions of the strand 158 between the terminal ends 164, 166 can be fused or otherwise fixed to the base, lateral, and medial portions 124, 130, 132.

**[0072]** Accordingly, tensioning the shoelace 155 can, in turn, increase tension in the strand 158. For instance, as shown in FIG. 10, when the shoelace 155 is loose and in the unsecured position, tension in the strand 158 can be relatively low, thereby allowing the upper 120 to fit loosely about the wearer's foot. However, when the shoelace 155 is pulled and tensioned as indicated by arrows 174, 175, the shoelace 155 can pull on the turns 159, 160 to increase tension in the strand 158. As a result, the strand 158 can pull and conform the upper 120 closely to the wearer's foot as indicated by arrows 176, 177, 178, 179 in FIG. 11.

**[0073]** It will be appreciated that in the embodiments shown in FIGS. 10 and 11, the strand 158 can provide support for various areas on the bottom of the wearer's foot. For instance, the strand 158 can be disposed on an arch region 164 that is configured to be disposed underneath the arch of the wearer's foot. Thus, the strand 158 within the arch region 164 can support the wearer's arch, especially when the strand 158 is tensioned by the shoelace 155.

**[0074]** It will also be appreciated that, in the embodiments illustrated, the upper 120 can include only one continuous strand 158 for providing such support to the foot. Accordingly, the part count of the upper 120 can be relatively low, and the upper 120 can be constructed in an efficient manner.

#### 40 Assembly of the Footwear

**[0075]** Assembly of the footwear 100, the knitted component 116 and upper 120 will now be discussed according to exemplary embodiments. For purposes of clarity, it will be assumed that the knitted component 116 and the strand 158 have been formed to the disassembled state shown in FIGS. 5 and 6.

**[0076]** To begin exemplary embodiments of the assembly of the upper 120, the lateral and medial portions 130, 132 can be moved (folded) superiorly to the position shown in FIG. 4. Then, the tongue portion 136 can be wrapped superiorly such that the curved region 143 substantially fills the gap 139 and the longitudinal region 145 substantially fills the throat 131. As such, the first and second edge portions 140, 142 can be disposed directly adjacent each other. Then, the first and second edge portions 140, 142 can be joined at a seam 144.

**[0077]** The first and second edge portions 140, 142

can be joined at the seam 144 in any suitable fashion. For instance, the first and second edge portions 140, 142 can be joined using stitching, adhesives, tape, bonding, welding, fasteners, or other suitable attachment devices.

**[0078]** In some embodiments, the seam 144 can be formed by stitching the edge portions 140, 142 together with stitching 146 as shown in FIGS. 1-3. As mentioned above, the upper 120 can be a knitted element with a plurality of stitches; however, it will be appreciated that the stitching 146 can be independent of the stitches of the knitted component 116. Stated differently, the stitching 146 can be formed using one or more threads, yarns, cables, or other strands that are attached after the knitted component 116 has been knitted. The stitching 146 can also be a zigzag stitch or other suitable stitch. Additionally, the edge portions 140, 142 can abut at the seam 144. For instance, the edge portions 140, 142 can form a butt joint, or the edge portions 140, 142 can be partially overlapped to form the seam 144. Additionally, the edge portions 140, 142 can be slightly spaced apart at the seam 144 with a bead of adhesive or other material between the edge portions 140, 142 at the seam 144.

**[0079]** Moreover, the seam 144 can extend across any suitable portion of the knitted component 116. For instance, in the embodiments of FIG. 3, the seam 144 can include a first terminal end 147 disposed in the base portion 124, adjacent the forefoot portion 134. The seam 144 can also include a second terminal end 149 at the junction of the lateral edge 135, the forefoot portion 134, and the tongue portion 136. Also, the seam 144 can extend continuously between the first and second terminal ends 147, 149 in some embodiments. For instance, the seam 144 can include a first portion 181 that extends across the base portion 124 generally in the transverse direction 127 toward the medial portion 132 from the first terminal end 147. The seam 144 can also include a second portion 183 that extends generally in the vertical direction 129 across the medial portion 132 and adjacent the forefoot portion 134. The seam 144 can further include a third portion 185 that extends generally in the transverse direction toward the lateral side 130 and that curves rearwardly toward the second terminal end 149. Thus, the seam 144 can extend continuously between the ends 147, 149 so as to extend from under the wearer's foot, around a medial area of the wearer's forefoot, to an area above the wearer's forefoot.

**[0080]** Also, there can be any number of seams 144 of the knitted component 116. As shown in the embodiments of FIG. 3, for instance, there can be only one, solitary seam 144 necessary for giving the knitted component 116 of the upper 120 the three dimensional shape shown in FIGS. 1-3. This can facilitate manufacturing and reduce time for assembly of the upper 120.

**[0081]** Also, the seam 144 can be spaced from the heel portion 128 such that the heel portion 128 is seamless. Thus, even if the heel portion 128 shifts on the wearer's heel, the relatively smooth and seamless heel portion 128 is unlikely to rub on the wearer's heel and provide

discomfort to the wearer.

**[0082]** Subsequently, the shoelace 155 can be threaded through the lateral and medial openings 156, 157 and the lateral and medial turns 159, 160 as discussed above.

Next, the sole structure 110 can be attached to the upper 120. Specifically, the midsole 112 can be attached to the exterior surface 123 of the base portion 124, and the outsole 114 can be attached to the midsole 112. In additional embodiments, an additional sockliner can be inserted over and/or attached to the interior surface 121 of the base portion 124.

### Exemplary Knitting Processes for Forming Knitted Component and Upper

**[0083]** The knitted component 116 can be knitted in any suitable direction. For instance, the knitted component 116 can be formed from the heel portion 128, at the collar 133, and the knitted component 116 can be formed so as to grow generally in the longitudinal direction 125 toward the forefoot portion 134. The forefoot cavity 150 can be formed before the tongue portion 136. Then, the tongue portion 136 can be subsequently formed. It will also be appreciated that the three dimensionally curved cavities and the two dimensionally curved portions of the knitted component 116 (such as the heel cavity 148, the forefoot cavity 150, the curved region 143 and/or other areas) can be formed unitarily during the knitting process. Specifically, the stitches at the boundaries 173, 197 can be held by respective needles as subsequent courses of stitches are added, and the held stitches at the boundaries 173, 197 can be knitted to respective stitches across the boundaries 173, 197. Also, the strand 158 can be inlaid during this knitting process. Also, this process can be completed on any suitable machine, such as a flat knitting machine.

**[0084]** Referring now to FIGS. 15-23, exemplary automated knitting processes for forming the knitted component 116 with the strand 158 will be discussed. For purposes of discussion, flat knitting processes and flat knitting machines will be discussed, however, the knitted component 116 and strand 158 can be otherwise formed without departing from the scope of the present disclosure. Thus, the knitted component 116 and strand 158 can be formed according to the teachings of U.S. Patent Publication No. 2012/0233882, which published September 20, 2012.

**[0085]** Referring to Figure 15, a portion of knitting machine 1200 that includes various needles 1202, rail 1203, standard feeder 1204, and combination feeder 1220 is depicted. Whereas combination feeder 1220 is secured to a front side of rail 1203, standard feeder 1204 is secured to a rear side of rail 1203. Yarn 1206 passes through combination feeder 1220, and an end of yarn 1206 extends outward from dispensing tip 1246. Although yarn 1206 is depicted, any other strand (e.g., filament, thread, rope, webbing, cable, chain, or yarn) may pass through combination feeder 1220. Another yarn

1211 passes through standard feeder 1204 and forms a portion of a knitted component 1260, and loops of yarn 1211 forming an uppermost course in knitted component 1260 are held by hooks located on ends of needles 1202.

**[0086]** The knitting process discussed herein relates to the formation of knitted component 1260 or portion of knitted component 1260. Thus, the portion of the knitted component 1260 can correspond to the base portion 124, the heel portion 128, the lateral portion 130, the medial portion 132, the forefoot portion 134, and/or the tongue portion 136 discussed above in relation to FIGS. 1-6. For purposes of the discussion, only a relatively small section of knitted component 1260 is shown in the figures in order to permit the knit structure to be illustrated. Moreover, the scale or proportions of the various elements of knitting machine 1200 and knitted component 1260 may be enhanced to better illustrate the knitting process.

**[0087]** Referring now to FIG. 16, standard feeder 1204 moves along rail 1203 and a new course is formed in knitted component 1260 from yarn 1211. More particularly, needles 1202 pulled sections of yarn 1211 through the loops of the prior course, thereby forming the new course. Accordingly, courses may be added to knitted component 1260 by moving standard feeder 1204 along needles 1202, thereby permitting needles 1202 to manipulate yarn 1211 and form additional loops from yarn 1211.

**[0088]** Continuing with the knitting process, feeder arm 1240 now translates from the retracted position to the extended position, as depicted in FIG. 17. In the extended position, feeder arm 1240 extends downward from carrier 1230 to position dispensing tip 1246 in a location that is (a) centered between needles 1202 and (b) below the intersection of needle beds.

**[0089]** Referring now to FIG. 18, combination feeder 1220 moves along rail 1203 and yarn 1206 is placed between loops of knitted component 1260. That is, yarn 1206 is located in front of some loops and behind other loops in an alternating pattern. Moreover, yarn 1206 is placed in front of loops being held by needles 1202 from one needle bed 1201, and yarn 1206 is placed behind loops being held by needles 1202 from the other needle bed. Note that feeder arm 1240 remains in the extended position in order to inlay yarn 1206 in the area below the intersection of needle beds. This effectively places yarn 1206 within the course recently formed by standard feeder 1204 in FIG. 16.

**[0090]** In order to complete inlaying yarn 1206 into knitted component 1260, standard feeder 1204 moves along rail 1203 to form a new course from yarn 1211, as depicted in FIG. 19. By forming the new course, yarn 1206 is effectively knit within or otherwise integrated into the structure of knitted component 1260. At this stage, feeder arm 1240 may also translate from the extended position to the retracted position.

**[0091]** FIGS. 18 and 19 show separate movements of feeders 1204 and 1220 along rail 1203. That is, FIG. 18 shows a first movement of combination feeder 1220

along rail 1203, and FIG. 19 shows a second and subsequent movement of standard feeder 1204 along rail 1203. In many knitting processes, feeders 1204 and 1220 may effectively move simultaneously to inlay yarn 1206 and form a new course from yarn 1211. Combination feeder 1220, however, moves ahead or in front of standard feeder 1204 in order to position yarn 1206 prior to the formation of the new course from yarn 1211.

**[0092]** The general knitting process outlined in the above discussion provides an example of the manner in which strand 158 of FIGS. 1-6 may be located in the base portion 124, the lateral portion 130, and/or the medial portion 132 of the upper 120. More particularly, because of the reciprocating action of feeder arm 1240, the strand 158 may be located within a previously formed course prior to the formation of a new course.

**[0093]** Continuing with the knitting process, feeder arm 1240 now translates from the retracted position to the extended position, as depicted in FIG. 20. Combination feeder 1220 then moves along rail 1203 and yarn 1206 is placed between loops of knitted component 1260, as depicted in FIG. 21. This effectively places yarn 1206 within the course formed by standard feeder 1204 in FIG. 19. In order to complete inlaying yarn 1206 into knitted component 1260, standard feeder 1204 moves along rail 1203 to form a new course from yarn 1211, as depicted in FIG. 22. By forming the new course, yarn 1206 is effectively knit within or otherwise integrated into the structure of knitted component 1260. At this stage, feeder arm 1240 may also translate from the extended position to the retracted position.

**[0094]** Referring to FIG. 22, yarn 1206 forms a loop 1214 between the two inlaid sections. In the discussion of the turns 159, 160 of FIGS. 1-6, it was noted that strand 158 exits the passage 162 and then enters another passage 162, thereby forming the turns 159, 160. Loop 1214 can be formed in a similar manner. That is, loop 1214 can be formed where yarn 1206 exits the knit structure of knitted component 1260 and then re-enters the knit structure.

**[0095]** Referring to FIG. 23, combination feeder 1220 moves along rail 1203 while in the retracted position and forms a course of knitted component 1260 while in the retracted position. Accordingly, by reciprocating feeder arm 1240 between the retracted position and the extended position, combination feeder 1220 may supply yarn 1206 for purposes of knitting, tucking, floating, and inlaying.

#### **Additional Embodiments of Knitted Component and Upper**

**[0096]** Additional embodiments of the knitted component 116 of the upper 220 which do not fall under the scope of the claimed invention are illustrated in FIG. 12. The knitted component 116 and upper 220 can be substantially similar to the knitted component 116 and upper 120 described above, except as discussed.

**[0097]** The upper 220 can include a strand 258 that alternately extends across the medial portion 232, the base portion 224, and the lateral portion 230, similar to the embodiments discussed above. The strand 258 can also extend through one or more passages 262. However, the passages 262 can be defined on the medial portion 132 and the lateral portion 130, and the passages 262 can be spaced away from the base portion 224.

**[0098]** Accordingly, longitudinal portions of the strand 258 extending across the base portion 224 can be exposed from the passages 262. Also, these portions of the strand 258 can be detached and decoupled from the base portion 224. Thus, in some embodiments, these portions of the strand 258 can be free to be attached directly to the sole structure 110.

**[0099]** Furthermore, as shown in FIG. 12, in some embodiments, the passages 262 can be V-shaped such that the turns of the strand 258 are embedded and enclosed within the passages 262 unlike the exposed turns 159, 160 shown above in FIGS. 1-6.

**[0100]** In some additional embodiments, a knitted component may be joined along various edge portions that are configured to come together at different locations on the assembled upper. In an exemplary embodiment, the upper can include a one-piece knit element that extends about the foot and wraps around the foot to cover over and under the wearer's foot. Various embodiments are within the scope of the present disclosure.

**[0101]** For example, exemplary embodiments of upper 320, knitted component 316, and article of footwear 300 in accordance with the invention are shown in FIGS. 24-34. Exemplary methods of manufacturing upper 320, knitted component 316, and article of footwear 300 are also illustrated. Upper 320 and knitted component 316 can be substantially similar to the embodiments discussed above, except as discussed. As shown, the upper 320 can be substantially defined by the knitted component 316; however, the upper 320 can include other structures or elements in addition to the knitted component 316 without departing from the scope of the present disclosure.

**[0102]** For reference purposes, upper 320 may be divided into three general regions: a forefoot region 311, a midfoot region 312, and a heel region 314. Forefoot region 311 can generally encompass portions of upper 320 corresponding with forward portions of the foot, including the toes and joints connecting the metatarsals with the phalanges. Midfoot region 312 can generally encompass portions of upper 320 corresponding with middle portions of the foot, including an arch area. Heel region 314 can generally encompass portions of upper 320 corresponding with rear portions of the foot, including the heel and calcaneus bone. Upper 320 can also include a lateral side 315 and a medial side 317, which can extend through forefoot region 311, midfoot region 312, and heel region 314, and which can correspond with opposite sides of upper 320. More particularly, lateral side 315 can correspond with an outside area of the foot (i.e. the

surface that faces away from the other foot), and medial side 317 can correspond with an inside area of the foot (i.e., the surface that faces toward the other foot). Forefoot region 311, midfoot region 312, heel region 314, lateral side 315, and medial side 317 are not intended to demarcate precise areas of upper 320. Rather, forefoot region 311, midfoot region 312, heel region 314, lateral side 315, and medial side 317 are intended to represent general areas of upper 320 to aid in the following discussion.

**[0103]** As shown in FIGS. 24-27, knitted component 316 of upper 320 can include a base portion 324 or strobil portion or underfoot portion. Base portion 324 can be shaped similar to the sole of a foot in some embodiments. In other embodiments, base portion 324 can have a different shape. Base portion 324 can be configured to be disposed underneath the wearer's foot as will be discussed. Stated differently, base portion 324 can be configured to be overlapped by the sole of the wearer's foot as will be discussed.

**[0104]** Also, knitted component 316 can include one or more portions that are adjacent base portion 324 and that extend from base portion 324. One or more of these adjacent portions can be integrally connected to base portion 324 and can be formed of unitary knit construction with base portion 324. Moreover, these adjacent portions can cooperate with base portion 324 to define void 322 within upper 320 for receiving the wearer's foot.

**[0105]** For example, in the embodiments shown in FIGS. 24-27, knitted component 316 can include a heel portion 328 that at least partially defines heel region 314 of upper 320. Knitted component 316 can also include a lateral portion 330 that at least partially defines lateral side 315 of upper 320. Moreover, knitted component 316 can include a medial portion 332 that at least partially defines medial side 317 of upper 320. Additionally, knitted component 316 can include a forefoot portion 334 that at least partially defines forefoot region 311 of upper 320. Heel portion 328, lateral portion 330, medial portion 332, and forefoot portion 334 can each be formed of unitary knit construction with base portion 324 in some embodiments.

**[0106]** Still further, knitted component 316 can include a throat portion 331. Throat portion 331 can be disposed between lateral portion 330 and medial portion 332. In some embodiments, throat portion 331 can be integrally attached to and formed of unitary knit construction with lateral portion 330, medial portion 332, and/or forefoot portion 334. In the exemplary embodiments shown, knitted component 316 can extend substantially continuously between lateral portion 330, throat portion 331, and medial portion 332. In other embodiments, throat portion 331 can be disconnected from lateral portion 330 and medial portion 332 such that throat portion 331 includes a tongue that is moveable within an opening between lateral portion 330 and medial portion 332.

**[0107]** Moreover, knitted component 316 of upper 320 can also include collar 333 with a rim 313. Rim 313 can

define an opening into void 322 within upper 320. As shown in the illustrated embodiments, collar 333 and rim 313 can extend annularly and continuously about medial portion 332, throat portion 331, lateral portion 330, and heel portion 328.

**[0108]** Similar to the embodiments discussed above with respect to FIGS. 1-6, knitted component 316 can include a knit element 343 formed of unitary knit construction. In some embodiments, knit element 343 can substantially define base portion 324, heel portion 328, lateral portion 330, medial portion 332, forefoot portion 334, and/or throat portion 331.

**[0109]** Knitted component 316 can also include one or more tensile strands that are coupled to knit element 343. There can be any suitable number of tensile strands, and the strand(s) can extend across any portion of knit element 343. For example, in some embodiments, knitted component 316 can include a first tensile strand 358 and a second tensile strand 359. First tensile strand 358 can be coupled to lateral portion 330 of knitted component 316 to be disposed on lateral side 315 of upper 320. Second tensile strand 359 can be coupled to medial portion 332 of knitted component 316 to be disposed on medial side 317 of upper 320. First tensile strand 358 and/or second tensile strand 359 can also be coupled to and can extend over heel portion 328, forefoot portion 334, and/or base portion 324 of knitted component 316 in some embodiments.

**[0110]** Moreover, first tensile strand 358 and second tensile strand 359 can be attached to knit element 343 in any suitable fashion. In some embodiments, first tensile strand 358 can be formed of unitary knit construction with lateral portion 330, and second tensile strand 359 can be formed of unitary knit construction with medial portion 332. For example, portions of first tensile strand 358 and/or second tensile strand 359 can be inlaid within at least one course and/or a wale of knit element 343. Other portions of first tensile strand 358 and second tensile strand 359 can be exposed and otherwise detached from knit element 343. Further details of first tensile strand 358 and second tensile strand 359 will be discussed in greater detail below according to exemplary embodiments.

**[0111]** Also, like the embodiments discussed above with respect to FIGS. 1-6, knitted component 316 can include one or more seams 344. Seam 344 can be defined where two or more edges of knitted component 316 are joined. Seam 344 can be defined in and can extend over any suitable area of upper 320. For example, seam 344 can include a first end 347 and a second end 349, and seam 344 can extend continuously between first end 347 and second end 349. More specifically, in some embodiments, first end 347 of seam 344 can be disposed generally at the rim 313 of collar 333 on either the medial side 317 or the lateral side 315 of upper 320, and the second end 349 can be disposed generally in the forefoot region 311 of upper 320. Seam 344 can also curve across different portions of knitted component 316 as will be

discussed in greater detail below.

**[0112]** Like the embodiments discussed above in relation to FIGS. 1-4, seam 344 can be secured in various ways without departing from the scope of the present disclosure. For example, seam 344 can be secured using stitching, adhesives, tape, bonding, welding, fasteners, or other suitable attachment devices. In embodiments in which seam 344 is secured with stitching, such stitching can be independent of stitches of knitted component 316. Such stitching can also be a zigzag stitch or other suitable stitch. Additionally, the edges that join at seam 344 can butt up against each other. In other embodiments, the edges can overlap each other at seam 344.

**[0113]** Referring now to FIGS. 28 and 29, knit element 343 of knitted component 316 will be discussed in greater detail according to exemplary embodiments. Knit element 343 is shown in plan view in a disassembled state in FIGS. 28 and 29. As shown, knit element 343 can be generally asymmetrical. Knit element 343 can also include an interior surface 321 as shown in FIG. 28 and an exterior surface 323 as shown in FIG. 29. Knit element 343 can also include an outer peripheral edge 339. Outer peripheral edge 339 can be defined by a first edge 340, a second edge 342, and rim 313 of collar 333. First edge 340 and second edge 342 can meet at a junction 337. Also, first edge 340 and rim 313 can meet at a first corner 335. Second edge 342 and rim 313 can meet at a second corner 341. As shown, first edge 340 can extend continuously between junction 337 and first corner 335, second edge 342 can extend continuously between junction 337 and second corner 341, and rim 313 can extend continuously between first corner 335 and second corner 341. Furthermore, first edge 340, second edge 342, and/or rim 313 can be curved in some embodiments.

**[0114]** Knit element 343 can be formed of unitary knit construction to define base portion 324, lateral portion 330, medial portion 332, throat portion 331, heel portion 328, and forefoot portion 334. A first side 390 of base portion 324 can be defined by first edge 340 of knit element 343. Also, lateral portion 330, throat portion 331, and medial portion 332 can extend from a second side 391 of base portion 324. Second side 391 of base portion 324 can be opposite the first side 390. As shown, in the exemplary embodiment illustrated in FIG. 28, lateral portion 330 can extend from base portion 324 and away from first edge 340. Moreover, throat portion 331 can extend from lateral portion 330 and away from base portion 324. Additionally, medial portion 332 can extend from throat portion 331 and away from lateral portion 330, and medial portion 332 can terminate at second edge 342.

**[0115]** As shown in the exemplary embodiment of FIG. 28, forefoot portion 334 can be disposed on knit element 343 such that forefoot portion 334 is defined partially by second edge 342, adjacent junction 337. Also, forefoot portion 334 can be bordered by medial portion 332, lateral portion 330, and throat portion 331. Furthermore, heel portion 328 can be partially defined by first edge 340 and partially defined by rim 313 adjacent first corner 335.

**[0116]** As shown in FIG. 28, interior surface 321 of knit element 324 at heel portion 328 can have three dimensional concave curvature. As such, heel portion 328 of knit element 324 can define a heel cavity 348. It will be appreciated that other portions of knit element 324 can also have three dimensional curvature and can define a respective cavity in additional embodiments.

**[0117]** Also, as shown in FIG. 28, collar 333 can extend continuously between first edge 340 and second edge 342. Moreover, collar 333 can extend from medial portion 332, throat portion 331, lateral portion 330, and heel portion 328.

**[0118]** Knit element 343 can also include two or more areas having different characteristics. For example, some areas of knit element 343 can have greater elasticity than other areas due to the types of yarns used in each area, due to the stitch density within the areas, or due to other reasons. Also, some portions of knit element 343 can be substantially continuous, while other areas can include a plurality of openings. For example, as shown in FIG. 28, base portion 324 can include a plurality of openings 352. The openings 352 can be arranged in a pattern such that base portion 324 has a mesh-type of appearance. In some embodiments, the base portion 324 can have a 4x4 knit mesh pattern to form openings 352. Also, as shown in FIG. 28, base portion 324 can include a border 353 that encompasses openings 352. Border 353 can have a relatively smooth, continuous appearance. It will be appreciated that openings 352 can reduce weight of the knit element 343. Also, openings 352 can reduce the surface area of base portion 324 that attaches with sole structure 310. As such, flexure of the base portion 324 and/or the sole structure 310 can be increased. It will also be appreciated that other areas of knit element 343 can include openings 352 and/or border 353 without departing from the scope of the present disclosure.

**[0119]** Moreover, knitted component 316 can include first tensile strand 358 and second tensile strand 359, which are coupled to knit element 343. Exemplary embodiments of first tensile strand 358 and second tensile strand 359 will now be discussed in greater detail.

**[0120]** As shown in FIGS. 28 and 29, first tensile strand 358 can include a first end 361 and a second end 363. First end 361 and second end 363 can both be disposed adjacent first edge 340. First end 361 and second end 363 can also be spaced apart relative to each other along first edge 340. Between first end 361 and second end 363, first tensile strand 358 can extend back and forth and alternate between first edge 340 and throat portion 331. Thus, as shown in the exemplary embodiment of FIGS. 28 and 29, first tensile strand 358 can extend across and can be coupled to base portion 324, lateral portion 330, and heel portion 328.

**[0121]** More specifically, first tensile strand 358 can include a plurality of attached portions 365 that are attached to knit element 343 and that extend between first edge 340 and throat portion 331. In some embodiments, attached portions 365 can be inlaid within a course or

wale of knit element 343 as described above. Also, attached portions 365 can extend transverse to the first edge 340. Moreover, attached portions 365 can be spaced apart from each other relative to first edge 340. A representative first attached portion is indicated at 366 in FIGS. 28 and 29, and a representative second attached portion is indicated at 368.

**[0122]** First tensile strand 358 can also include a plurality of exposed portions 367 that extend along first edge 340 and between adjacent pairs of attached portions 365. Exposed portions 367 can be exposed and detached from knit element 343. As an example, FIGS. 28 and 29 includes a representative third exposed portion indicated at 364. As shown, third exposed portion 364 extends continuously between first attached portion 366 and second attached portion 368. Also, third exposed portion 364 can extend generally along first edge 340 between the first attached portion 366 and second attached portion 368.

**[0123]** Second tensile strand 359 can include a first end 371 and a second end 373. First end 371 and second end 373 can be disposed adjacent second edge 342. First end 371 and second end 373 can also be spaced apart from each other along second edge 342. Second tensile strand 359 can also extend back and forth and alternate between second edge 342 and throat portion 331. Thus, like first tensile strand 358, second tensile strand 359 can include a plurality of spaced-apart attached portions 375 extending transverse to second edge 342 and a plurality of exposed portions 377 that extend along second edge 343 between respective pairs of attached portions 375. Also, as shown in the exemplary embodiments of FIGS. 28 and 29, second tensile strand 359 can extend across and can be coupled to medial portion 332.

**[0124]** Assembly of knitted component 316, upper 320, and article of footwear 300 will now be discussed. Knitted component 316 can be formed via the knitting processes discussed in detail above. As such, knitted component 316 can include knit element 343, first tensile strand 358, and second tensile strand 359 as represented in FIGS. 28 and 29.

**[0125]** Next, as shown in FIG. 30, first edge 340 and/or second edge 342 can be moved toward the other to provide knitted component 316 with three dimensional curvature. For example, in some embodiments represented in FIG. 30 and 31, knitted component 316 can be supported on a support member 369 to facilitate this assembly process. As shown, support member 369 can be shaped similar to an anatomical foot and can be referred to as a "last". Thus, base portion 324 can be layered under support member 369, and support member 369 can be received within heel cavity 348 of knitted component 316. In some embodiments, knitted component 316 can be temporarily secured along first edge 340 to support member 369 using pins or other fasteners.

**[0126]** Then, as shown in FIG. 30, medial portion 332, forefoot portion 334, and throat portion 331 can be pulled up and over support member 369 such that knitted com-

ponent 316 is substantially wrapped about support member 369. Stated differently, medial portion 332 can be moved adjacent first side 390 of base portion 324, second corner 341 can be moved adjacent first corner 335, and second edge 342 can be moved adjacent first edge 340. As such, knitted component 316 can largely define the void 322 within upper 320. Second edge 342 can also be temporarily secured to support member 369 in this position using pins or other fasteners.

**[0127]** Subsequently, seam 344 can be formed by joining first edge 340 and second edge 342 of knitted component 316. First edge 340 can be joined to second edge 342 in any suitable way, such as stitching, adhesives, fasteners, or other attachment device. As shown in the embodiment of FIG. 32, for example, seam 344 is formed with stitching 379. Stitching 379 can be included by hand or can be formed automatically. Stitching 379 can be included in any suitable pattern, such as cross stitch or other type. Furthermore, stitching 379 can be added in a direction extending from junction 337 to rim 313 as shown in FIG. 32. Stitching 379 can also be added in the opposite direction in some embodiments.

**[0128]** Once first edge 340 and second edge 342 are joined by stitching 379, knitted component 316 can have a sock-like construction, and knitted component 316 can substantially cover, receive, and enclose support member 369. Also, in this configuration, knitted component 316 can define upper 320 for article of footwear 300. In other embodiments, additional bodies, members, logos, tags, or other objects can be added to knitted component 316 to form upper 320.

**[0129]** It is noted that, once knitted component 316 is assembled, first end 347 of seam 344 can be located on the medial side 317 of rim 313 of collar 333 as shown in the exemplary embodiment of FIG. 27. Also, first corner 335 and second corner 341 of knit element 343 can meet to form first end 347 of seam 344. A first portion 381 of seam 344 can extend downward from first end 347 along medial side 317 toward base portion 324 in a vertical direction. A second portion 382 of seam 344 can extend continuously from first portion 381 and can extend forward toward forefoot portion 334 in a longitudinal direction. Also, second portion 382 can be disposed between medial portion 332 and base portion 324 and can curve in two or three dimensions. Furthermore, a third portion 383 can extend continuously from second portion 382 and upward and away from base portion 324. Moreover, a fourth portion 384 of seam 344 can extend continuously in a lateral direction from third portion 383 along forefoot region 311 toward lateral portion 330, and fourth portion 384 of seam 344 can terminate at second end 349. Moreover, it is noted that junction 337 can become the second end 349 of the seam 344.

**[0130]** With this configuration, exemplary embodiment of seam 344 may assist with providing improved comfort and/or fit to article of footwear 300 for a wearer's foot. For example, first end 347 and first portion 381 of seam 344 can extend along medial side 317 of upper 320. Stat-

ed differently, seam 344 can be spaced away from heel region 314 of upper 320 and heel region 314 can be largely seamless. As such, upper 320 can more closely lie against and support the wearer's heel. Also, upper 320 is unlikely to uncomfortably rub against the wearer's heel.

**[0131]** Moreover, second portion 382 of seam 344 can have an arched curvature that is configured to substantially nest with the anatomical arch of the wearer's foot. As such, wearer is less likely to step directly on seam 344 while walking, running, or jumping. Thus, upper 320 can better support the wearer's foot, and the upper 320 is likely to be comfortable to wear.

**[0132]** Additionally, once upper 320 has been assembled, sole structure 310 can be attached to knitted component 316 as shown in FIGS. 33 and 34. Sole structure 310 can be of any suitable type, and sole structure 310 can be layered on and attached to base portion 324 of knitted component 316. For example, sole structure 310 can include one or more features that increase flexibility of sole structure 310 and footwear 300. Such features can include a recess, a groove, a sipe, areas that are thinner than surrounding areas, or other openings in sole structure 310. As shown in FIGS. 33 and 34, sole structure 310 can include one or more flex grooves 303 that increase flexibility of sole structure 310. Flex grooves 303 can extend between medial side 317 and lateral side 315 in some embodiments.

**[0133]** As mentioned above, border 353 of base portion 324 can provide a suitable surface for attaching to sole structure 310. Regions of base portion 324 enclosed by border 353 can also be attached to sole structure 310. Sole structure 310 can be attached using adhesives, fasteners, or other attachment device. Additionally, in some embodiments, sole structure 310 can cover over at least part of seam 344. For example, sole structure 310 can cover second portion 382 and part of third portion 383 of seam 344. Accordingly, seam 344 can be substantially hidden by sole structure 310 such that upper 320 appears largely continuous.

**[0134]** Furthermore, as mentioned, base portion 324 of upper 320 can include one or more openings 352. Areas of base portion 324 between openings 352 can also attach to sole structure 310. For example, in the embodiments represented in FIG. 34, the sole structure 310 can bond to areas of base portion 324 between openings 352. Also, in some embodiments, the support member 369 can include surfaces that are unlikely to bond to sole structure 310. For example, support member 369 can be at least partially made from TEFLON™ or other suitable material that is unlikely to bond to sole structure 310 when sole structure 310 is attached to upper 320.

**[0135]** Moreover, once upper 320 has been assembled, it is noted that exposed portions 367 of first tensile strand 358 and exposed portions 377 of second tensile strand 359 can extend along and can be aligned with seam 344. In some embodiments, stitching 379 can bind and retain exposed portions 367 of first tensile strand 358 and exposed portions 377 of second tensile strand

359. Accordingly, first tensile strand 358 and second tensile strand 359 can be retained in predetermined positions relative to knit element 343.

**[0136]** Also, once upper 320 has been assembled, attached portions 365 of first tensile strand 358 can be substantially aligned across seam 344 with respective attached portions 375 of second tensile strand 359. This alignment can make the upper 320 more aesthetically pleasing since both lateral side 315 and medial side 317 can appear substantially the same. Also, first tensile strand 358 and second tensile strand 359 can generally support corresponding areas of lateral side 315 and medial side 317, respectively, for greater comfort and performance.

**[0137]** As demonstrated by the above discussion, seam 344 can define a boundary between base portion 324 and medial portion 332 of knitted component 316. Seam 344 can also define a boundary between base portion 324 and forefoot portion 334 of knitted component 316. However, it will be appreciated that seam 344 can bisect any individual portion of knitted component 316. For example, seam 344 can bisect base portion 324 into two or more sub-divisions in some embodiments. Similarly, seam 344 can bisect another portion of knitted component 316 without departing from the scope of the present disclosure.

**[0138]** Furthermore, knitted component 316 could be configured such that seam 344 extends from rim 313 on lateral side 315 of upper 320 and downward toward base portion 324 without departing from the scope of the present disclosure. Even in these embodiments, heel region 314 could be seamless. As such, upper 320 can be comfortable to wear and can provide support to the wearer's heel as discussed above.

**[0139]** In some additional embodiments, the knitted component could also be constructed such that the seam extends across other areas of the upper. For example, one end of the seam could extend along the rear side of the heel in some embodiments. Also, in some embodiments, the tensile strands can be arranged relative to the sole structure to enhance particular characteristics of the footwear. For example, the tensile strands can be arranged relative to the sole structure to support flexure of footwear and/or to improve the aesthetics of the footwear.

**[0140]** For example, additional exemplary embodiments of article of footwear 400 are illustrated according to the present disclosure. In some embodiments, article of footwear 400 can be substantially similar to the embodiments illustrated in FIGS. 24-34 except as noted below.

**[0141]** As shown in FIGS. 35 and 36, in accordance with the invention, upper 420 can include a knitted component 416 having a knit element 443. Knit element 443 can define a base portion 424, a heel portion 428, a lateral portion 430, a medial portion 432, a forefoot portion 434, a throat portion 431, and a collar 433 with a rim 413, similar to the embodiments discussed above with respect to FIGS. 24-34.

**[0142]** However, as shown in FIG. 36, a seam 444 of knitted component 416 can include a first end 447 that terminates at rim 413 of the heel region 414, between lateral side 415 and medial side 417 of upper 420. A first portion 481 of seam 444 can extend from first end 447, downward toward base portion 424. A second portion 482 of seam 444 can extend from first portion 481 and longitudinally toward forefoot portion 434 as shown in FIG. 35. Remaining portions of seam 444 can be similar to the embodiments shown in FIGS. 24-34.

**[0143]** Thus, seam 444 of knitted component 416 can divide heel portion 424 of knitted component 416 into multiple portions in some embodiments. More specifically, heel portion 424 of knitted component 416 can include a first portion 487 and a second portion 489 that are disposed on opposite sides of seam 444. Stated differently, first portion 487 and second portion 489 can be joined at seam 444 and can cooperate to define heel portion 424 of knitted component 416. It will be appreciated that other areas of knitted component 416 could be similarly divided by seam 444.

**[0144]** Moreover, as shown in FIG. 37, knitted component 416 can include one or more three dimensionally curved surfaces. For example, first portion 487 of heel portion 424 can have respective surfaces with three dimensional curvature, and second portion 489 can also have surfaces with three dimensional curvature. The degree of curvature can be less than the curvature of the heel cavity 348 shown in FIG. 28. It will also be appreciated that other portions of the knitted component 416 can include three dimensionally curved surfaces.

**[0145]** Moreover, like the embodiments of FIGS. 24-34, first tensile strand 458 and second tensile strand 459 can include one or more portions that are substantially aligned on opposite sides of seam 444. For example, a portion 465 of first tensile strand 458 and a portion 475 of second tensile strand 459 can be substantially aligned across seam 444. Other portions of first tensile strand 458 can similarly align with respective portions of second tensile strand 459 across seam 444.

**[0146]** First tensile strand 458 and second tensile strand 459 can also be disposed in a predetermined position relative to the sole structure 410. For example, as shown in FIG. 38, flex groove 403 can overlap and can be aligned vertically with portion 465 of first tensile strand 458 and portion 475 of second tensile strand 459. As such, flex groove 403 can provide increased flexibility to footwear 400, and yet first tensile strand 458 and second tensile strand 459 can provide increased support at the areas above flex groove 403. Moreover, this alignment can improve the aesthetics of footwear 400.

## Claims

1. A knitted component (316) configured to form an upper (320) for an article of footwear (100), the upper configured to be attached to a sole structure (310),

the knitted component comprising:

- a base portion (324) with a first side (390) that is at least partially defined by a first edge (340) of the knitted component, the base portion configured to be disposed adjacent the sole structure;
- a heel portion (328) and a forefoot portion (334) that are formed of unitary knit construction with the base portion; and
- a medial portion (332) and a lateral portion (330) that extend from a second side (391) of the base portion, the second side being opposite from the first side, one of the medial portion and the lateral portion being at least partially defined by a second edge (342) of the knitted component, the second edge being configured to be joined to the first edge at a seam (344) to locate the one of the medial portion and the lateral portion adjacent the first side of the base portion and the other of the medial portion and the lateral portion adjacent the second side of the base portion, and wherein the second edge is configured to be joined to the first edge such that the base portion, the heel portion, the forefoot portion, the medial portion, and the lateral portion cooperatively define a void (322) that is configured to receive a foot,
- the knitted component being **characterized by** the knitted component further comprising a throat portion (331) that is formed of unitary knit construction with the medial portion, the lateral portion, and the forefoot portion.
2. The knitted component (316) of claim 1, wherein at least one of the heel portion (328) and the forefoot portion (334) includes a surface having three dimensional curvature that defines a cavity.
  3. The knitted component (316) of claim 2, wherein the heel portion (328) includes the surface having three dimensional curvature to define a heel cavity (348).
  4. The knitted component (316) of claim 1, further comprising a collar (333) with a rim (313) that is configured to define an opening into the void (322), the first edge (340) and the second edge (342) configured to be joined at a first end (347) of the seam (344), the first end disposed generally at the rim of the collar.
  5. The knitted component (316) of claim 1, further comprising a knit element (343) and a tensile strand (358), the knit element substantially defining the base portion (324), the forefoot portion (334), the heel portion (328), the medial portion (332), and the lateral portion (330), wherein the tensile strand is formed of unitary knit construction with the knit ele-

ment, wherein the tensile strand includes a first portion that extends along the knit element toward one of the first edge (340) and the second edge (342), and wherein the tensile strand includes a second portion that is substantially aligned with the one of the first edge and the second edge.

6. The knitted component (316) of claim 5, wherein the first portion is inlaid within the knit element (343), wherein the second portion is exposed from the knit element, wherein the tensile strand (358) further includes a third portion that is inlaid within the knit element, and wherein the second portion is disposed between the first portion and the third portion.
7. The knitted component (316) of claim 1, further comprising a knit element (343), a first tensile strand (358), and a second tensile strand (358), wherein the knit element substantially defines the base portion (324), the forefoot portion (334), the heel portion (328), the medial portion (332), and the lateral portion (330), wherein the first tensile strand (358) and the second tensile strand are formed of unitary knit construction with the knit element, wherein the first tensile strand includes a first portion that extends transverse relative to the first edge (340), wherein the second tensile strand includes a second portion that extends transverse relative to the second edge (342), and wherein the first portion and the second portion are configured to be disposed on opposite sides (390, 391) of the seam (344) and are substantially aligned with each other.

## Patentansprüche

1. Strickkomponente (316), die zur Bildung eines Obermaterials (320) für ein Schuhwerk (100) ausgebildet ist, wobei das Obermaterial zur Befestigung an einer Sohlenstruktur (310) ausgebildet ist, wobei die Strickkomponente Folgendes umfasst:
 

einen Basisabschnitt (324) mit einer ersten Seite (390), die zumindest teilweise durch eine erste Kante (340) der Strickkomponente definiert ist, wobei der Basisabschnitt zur Anordnung angrenzend an die Sohlenstruktur ausgebildet ist, einen Fersenabschnitt (328) und einen Vorderfußabschnitt (334), die aus einem einheitlichen Strickaufbau mit dem Basisabschnitt gebildet sind, und

einen medialen Abschnitt (332) und einen lateralen Abschnitt (330), die sich von einer zweiten Seite (391) des Basisabschnitts aus erstrecken, wobei die zweite Seite zur ersten Seite entgegengesetzt ist, wobei der mediale Abschnitt oder der laterale Abschnitt zumindest teilweise

- durch eine zweite Kante (342) der Strickkomponente definiert ist, wobei die zweite Kante dazu ausgebildet ist, an einer Naht (344) mit der ersten Kante verbunden zu werden, um den medialen Abschnitt oder den lateralen Abschnitt angrenzend an die erste Seite des Basisabschnitts festzulegen und den jeweils anderen, also den lateralen Abschnitt oder den medialen Abschnitt, angrenzend an die zweite Seite des Basisabschnitts festzulegen, und wobei die zweite Kante dazu ausgebildet ist, so mit der ersten Kante verbunden zu werden, dass der Basisabschnitt, der Fersenabschnitt, der Vorderfußabschnitt, der mediale Abschnitt und der laterale Abschnitt zusammenwirkend einen Hohlraum (322) definieren, der zur Aufnahme eines Fußes ausgebildet ist, wobei die Strickkomponente **dadurch gekennzeichnet ist, dass** die Strickkomponente ferner einen Halsabschnitt (331) umfasst, der aus einem einheitlichen Strickaufbau mit dem medialen Abschnitt, dem lateralen Abschnitt und dem Vorderfußabschnitt gebildet ist.
2. Strickkomponente (316) nach Anspruch 1, bei der der Fersenabschnitt (328) und/oder der Vorderfußabschnitt (334) eine Oberfläche mit dreidimensionaler Krümmung aufweist bzw. aufweisen, die eine Höhlung begrenzt.
  3. Strickkomponente (316) nach Anspruch 2, bei der der Fersenabschnitt (328) die Oberfläche mit dreidimensionaler Krümmung zur Bildung einer Fersenhöhle (348) aufweist.
  4. Strickkomponente (316) nach Anspruch 1, ferner mit einem Kragen (333) mit einem Rand (313), der zur Bildung einer Öffnung in den Hohlraum (322) ausgebildet ist, wobei die erste Kante (340) und die zweite Kante (342) dazu ausgebildet sind, an einem ersten Ende (347) der Naht (344) verbunden zu werden, wobei das erste Ende insgesamt am Rand des Kragens angeordnet ist.
  5. Strickkomponente (316) nach Anspruch 1, ferner mit einem Strickelement (343) und einem dehnbaren Strang (358), wobei das Strickelement im Wesentlichen den Basisabschnitt (324), den Vorderfußabschnitt (334), den Fersenabschnitt (328), den medialen Abschnitt (332) und den lateralen Abschnitt (330) bildet, wobei der dehnbare Strang aus einheitlichem Strickaufbau mit dem Strickelement gebildet ist, wobei der dehnbare Strang einen ersten Abschnitt aufweist, der sich entlang des Strickelements zur ersten Kante (340) oder zur zweiten Kante (342) hin erstreckt, und wobei der dehnbare Strang einen zweiten Abschnitt aufweist, der im Wesentlichen auf die erste Kante oder die zweite Kante ausgerichtet

ist.

6. Strickkomponente (316) nach Anspruch 5, bei der der erste Abschnitt in das Strickelement (343) eingelegt ist, der zweite Abschnitt von dem Strickelement freigelegt ist, der dehnbare Strang (358) ferner einen dritten Abschnitt aufweist, der in das Strickelement eingelegt ist, und der zweite Abschnitt zwischen dem ersten Abschnitt und dem dritten Abschnitt angeordnet ist.
7. Strickkomponente (316) nach Anspruch 1, ferner mit einem Strickelement (343), einem ersten dehnbaren Strang (358) und einem zweiten dehnbaren Strang (358), wobei das Strickelement im Wesentlichen den Basisabschnitt (324), den Vorderfußabschnitt (334), den Fersenabschnitt (328), den medialen Abschnitt (332) und den lateralen Abschnitt (330) bildet, wobei der erste dehnbare Strang (358) und der zweite dehnbare Strang aus einheitlichem Strickaufbau mit dem Strickelement gebildet sind, wobei der erste dehnbare Strang einen ersten Abschnitt aufweist, der sich bezüglich der ersten Kante (340) quer erstreckt, wobei der zweite dehnbare Strang einen zweiten Abschnitt aufweist, der sich bezüglich der zweiten Kante (342) quer erstreckt, und wobei der erste Abschnitt und der zweite Abschnitt zur Anordnung auf entgegengesetzten Seiten (390, 391) der Naht (344) ausgebildet und im Wesentlichen aufeinander ausgerichtet sind.

#### Revendications

1. Composant tricoté (316) réalisé de manière à former une tige (320) pour un article chaussant (100), la tige étant réalisée de manière à être fixée à une structure de semelle (310), le composant tricoté comprenant :
  - un tronçon de base (324) qui présente un premier côté (390) au moins partiellement défini par un premier bord (340) du composant tricoté, le tronçon de base étant réalisé de manière à être agencé adjacent à la structure de semelle ;
  - un tronçon de talon (328) et un tronçon d'avant-pied (334) qui sont réalisés d'un ensemble tricoté unitaire avec le tronçon de base ; et
  - un tronçon médian (332) et un tronçon latéral (330) qui s'étendent depuis un deuxième côté (391) du tronçon de base, le deuxième côté étant opposé au premier côté, le tronçon médian ou le tronçon latéral étant au moins partiellement défini par un deuxième bord (342) du composant tricoté,
  - le deuxième bord étant réalisé de manière à être assemblé au premier bord au niveau d'une couture (344) de façon à agencer le tronçon médian

- ou le tronçon latéral adjacent au premier côté du tronçon de base et l'autre du tronçon médian et du tronçon latéral adjacent au deuxième côté du tronçon de base, et le deuxième bord étant réalisé de manière à être assemblé au premier bord de telle sorte que le tronçon de base, le tronçon de talon, le tronçon d'avant-pied, le tronçon médian et le tronçon latéral définissent ensemble une cavité (322) qui est réalisée de manière à recevoir un pied, le composant tricoté étant **caractérisé en ce que** le composant tricoté comprend en outre un tronçon d'étranglement (331) qui est réalisé d'un ensemble tricoté unitaire avec le tronçon médian, le tronçon latéral et le tronçon d'avant-pied.
2. Composant tricoté (316) selon la revendication 1, dans lequel le tronçon de talon (328) et/ou le tronçon d'avant-pied (334) présente(nt) une surface à courbure tridimensionnelle définissant une cavité. 20
  3. Composant tricoté (316) selon la revendication 2, dans lequel le tronçon de talon (328) présente la surface à courbure tridimensionnelle de manière à définir une cavité de talon (348). 25
  4. Composant tricoté (316) selon la revendication 1, comprenant en outre une collerette (333) présentant une bordure (313) qui est réalisée de manière à définir une ouverture dans la cavité (322), le premier bord (340) et le deuxième bord (342) étant réalisés de manière à être assemblés à une première extrémité (347) de la couture (344), la première extrémité étant généralement agencée au niveau de la bordure de la collerette. 30 35
  5. Composant tricoté (316) selon la revendication 1, comprenant en outre un élément tricoté (343) et un cordon élastique (358), l'élément tricoté définissant sensiblement le tronçon de base (324), le tronçon d'avant-pied (334), le tronçon de talon (328), le tronçon médian (332) et le tronçon latéral (330), le cordon élastique étant réalisé d'un ensemble tricoté unitaire avec l'élément tricoté, le cordon élastique présentant un premier tronçon qui s'étend le long de l'élément tricoté vers le premier bord (340) ou le deuxième bord (342), et le cordon élastique présentant un deuxième tronçon qui est sensiblement aligné sur le premier bord ou le deuxième bord. 40 45 50
  6. Composant tricoté (316) selon la revendication 5, dans lequel le premier tronçon est inséré dans l'élément tricoté (343), le deuxième tronçon étant dégagé de l'élément tricoté, le cordon élastique (358) présentant en outre un troisième tronçon qui est inséré dans l'élément tricoté, et le deuxième tronçon étant agencé entre le premier tronçon et le troisième tronçon. 55
  7. Composant tricoté (316) selon la revendication 1, comprenant en outre un élément tricoté (343), un premier cordon élastique (358) et un deuxième cordon élastique (358), l'élément tricoté définissant sensiblement le tronçon de base (324), le tronçon d'avant-pied (334), le tronçon de talon (328), le tronçon médian (332), et le tronçon latéral (330), le premier cordon élastique (358) et le deuxième cordon élastique étant réalisés d'un ensemble tricoté unitaire avec l'élément tricoté, le premier cordon élastique présentant un premier tronçon qui s'étend transversalement par rapport au premier bord (340), le deuxième cordon élastique présentant un deuxième tronçon qui s'étend transversalement par rapport au deuxième bord (342), et le premier tronçon et le deuxième tronçon étant réalisés de manière à être agencés des côtés opposés (390, 391) de la couture (344) et étant sensiblement alignés l'un sur l'autre.

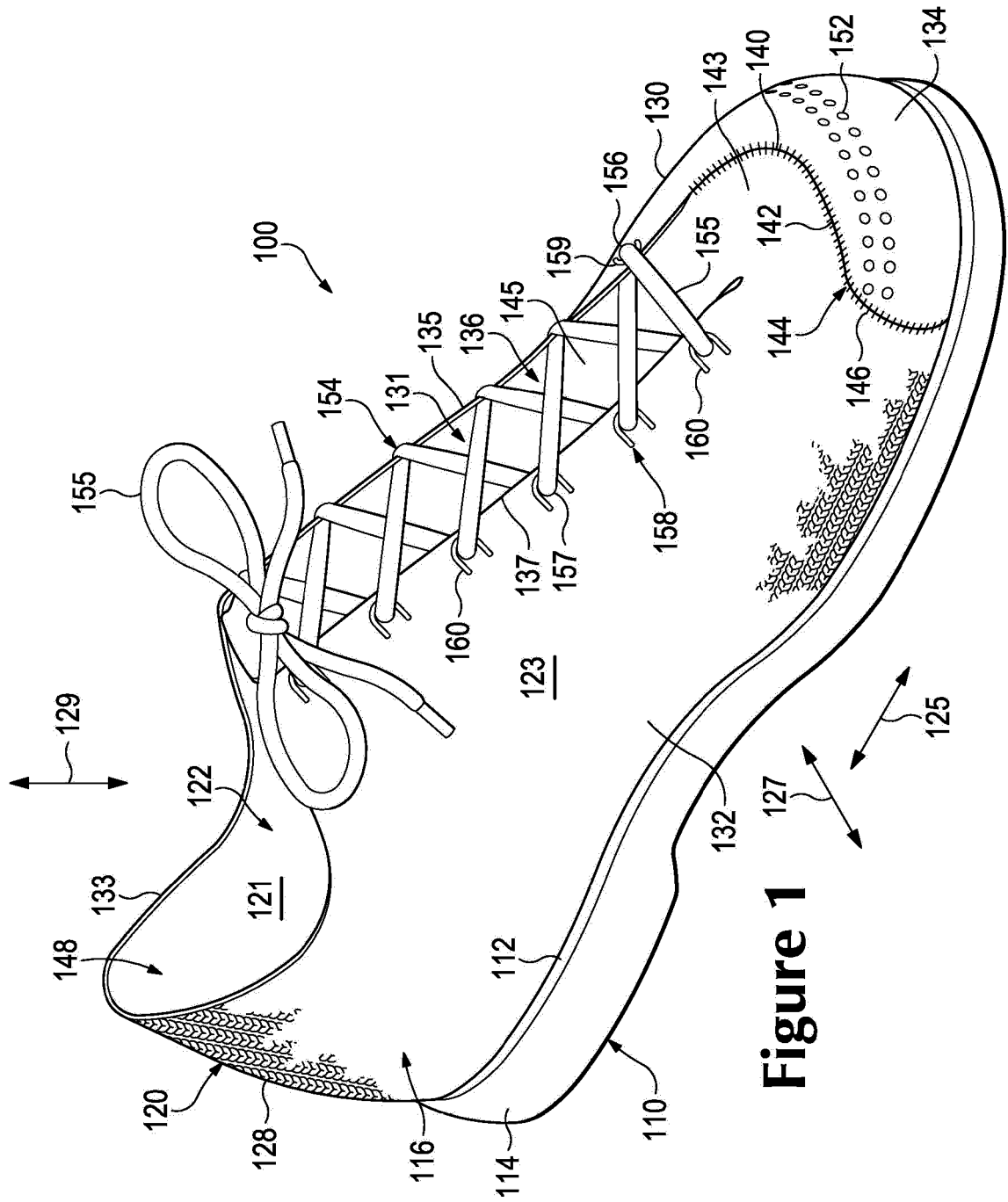
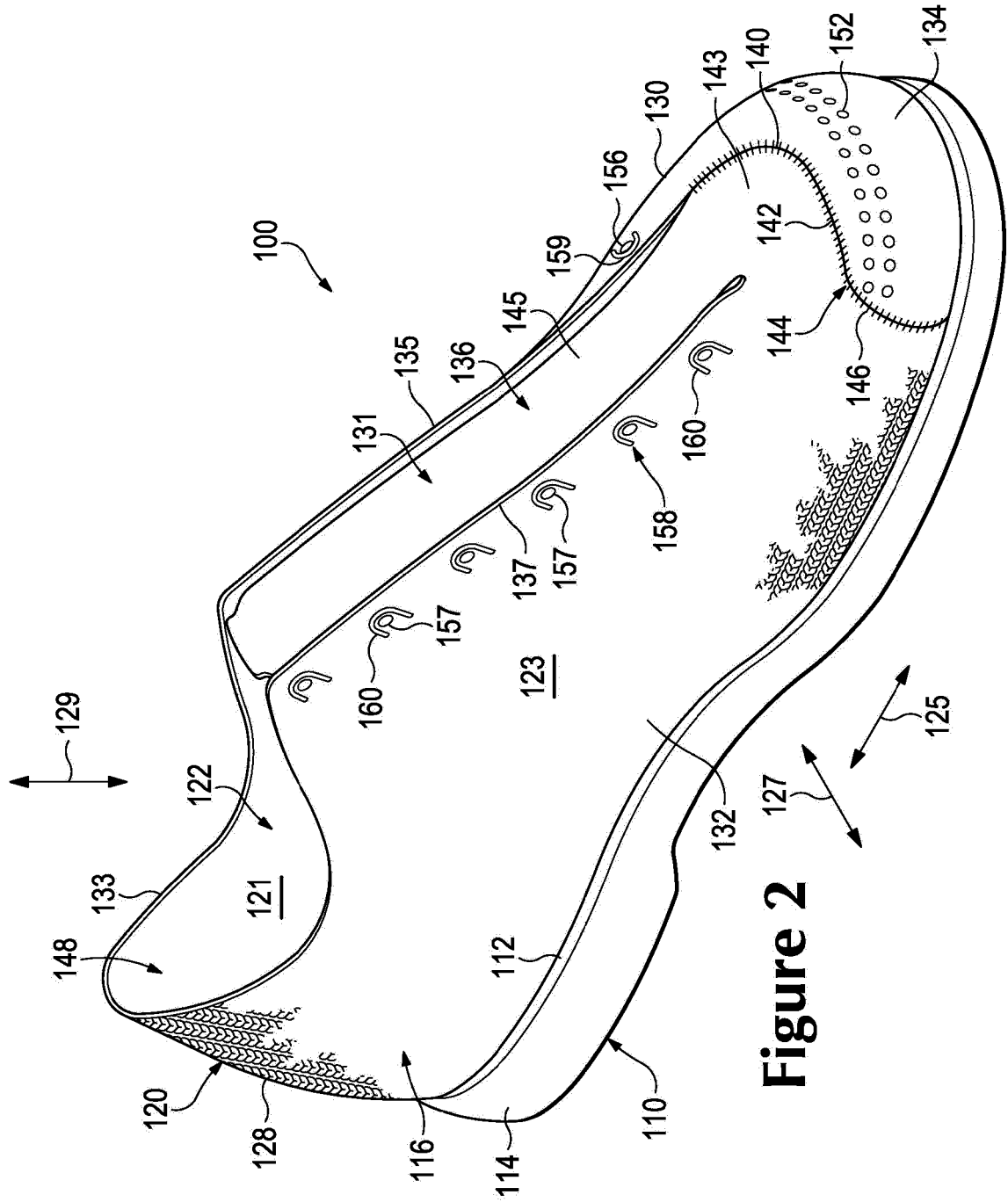

Figure 1



**Figure 2**

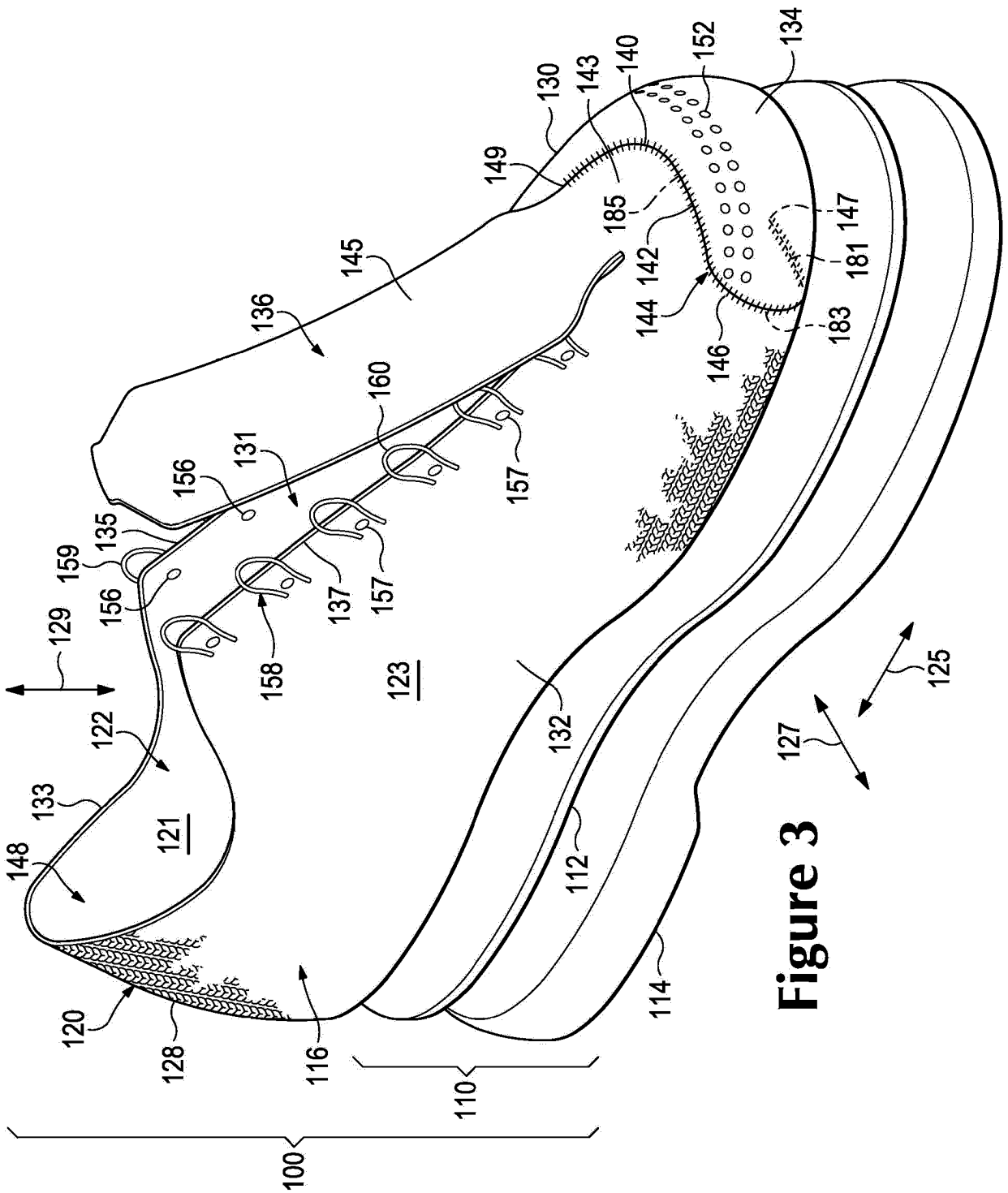
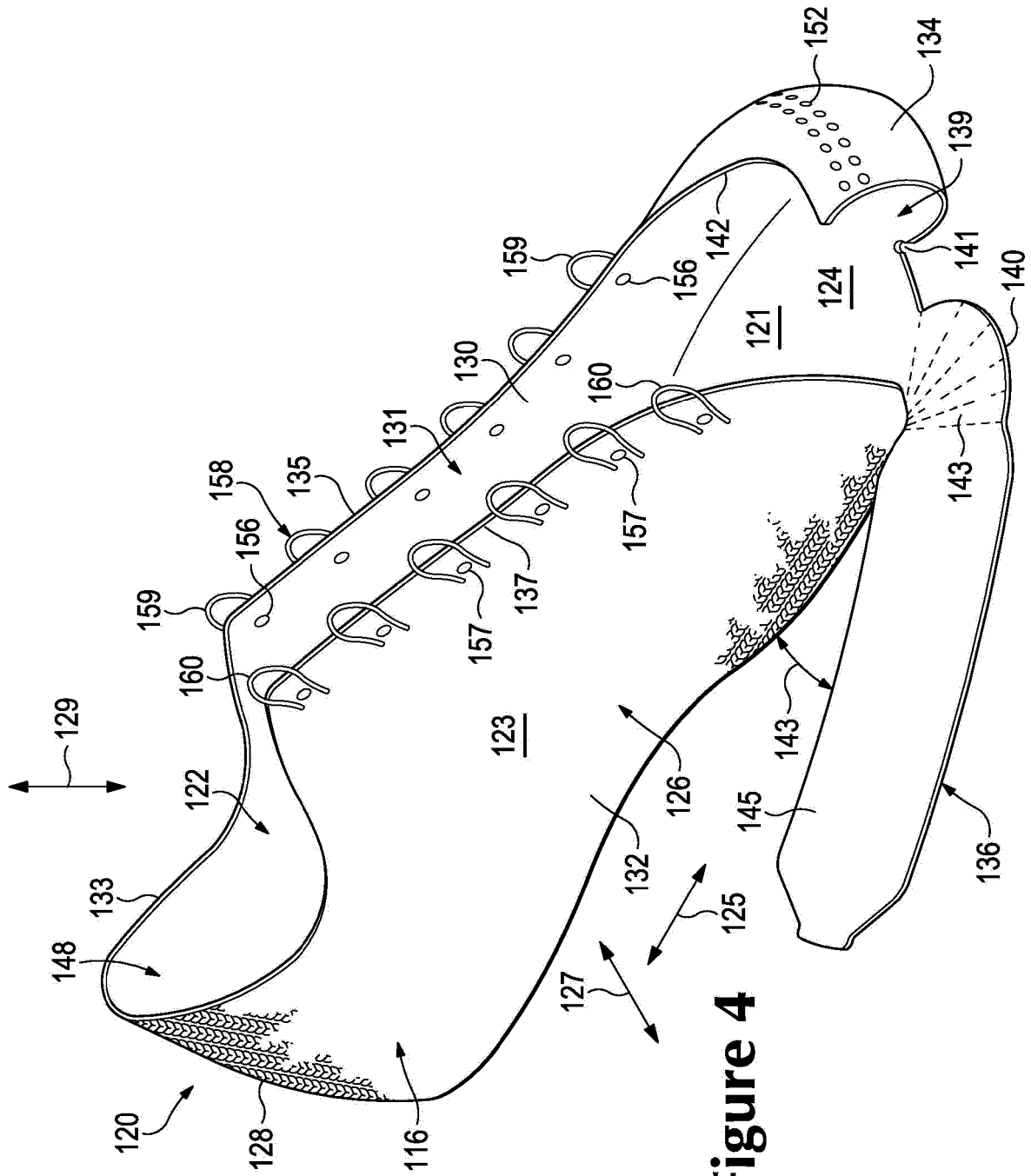
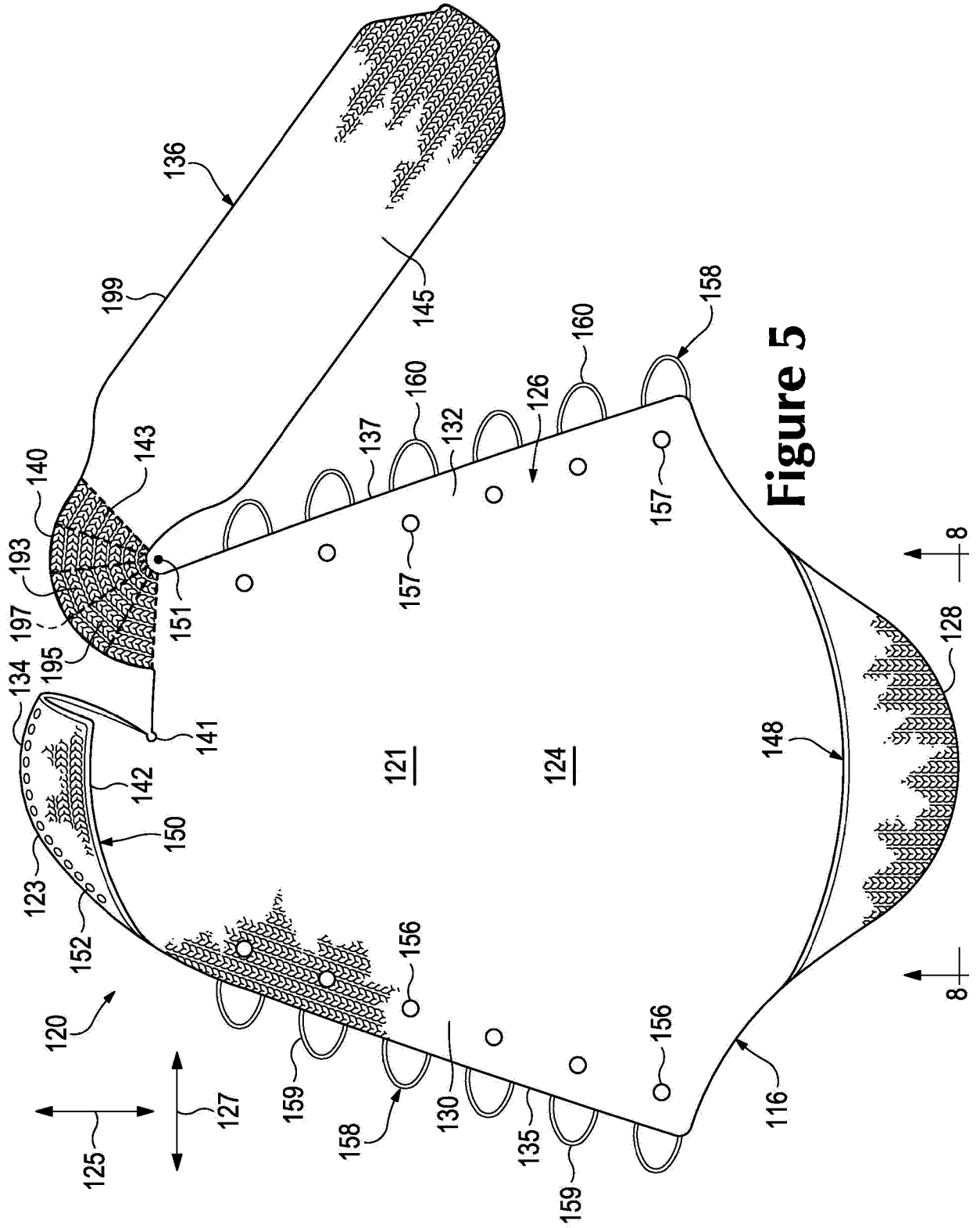

Figure 3



**Figure 4**



**Figure 5**

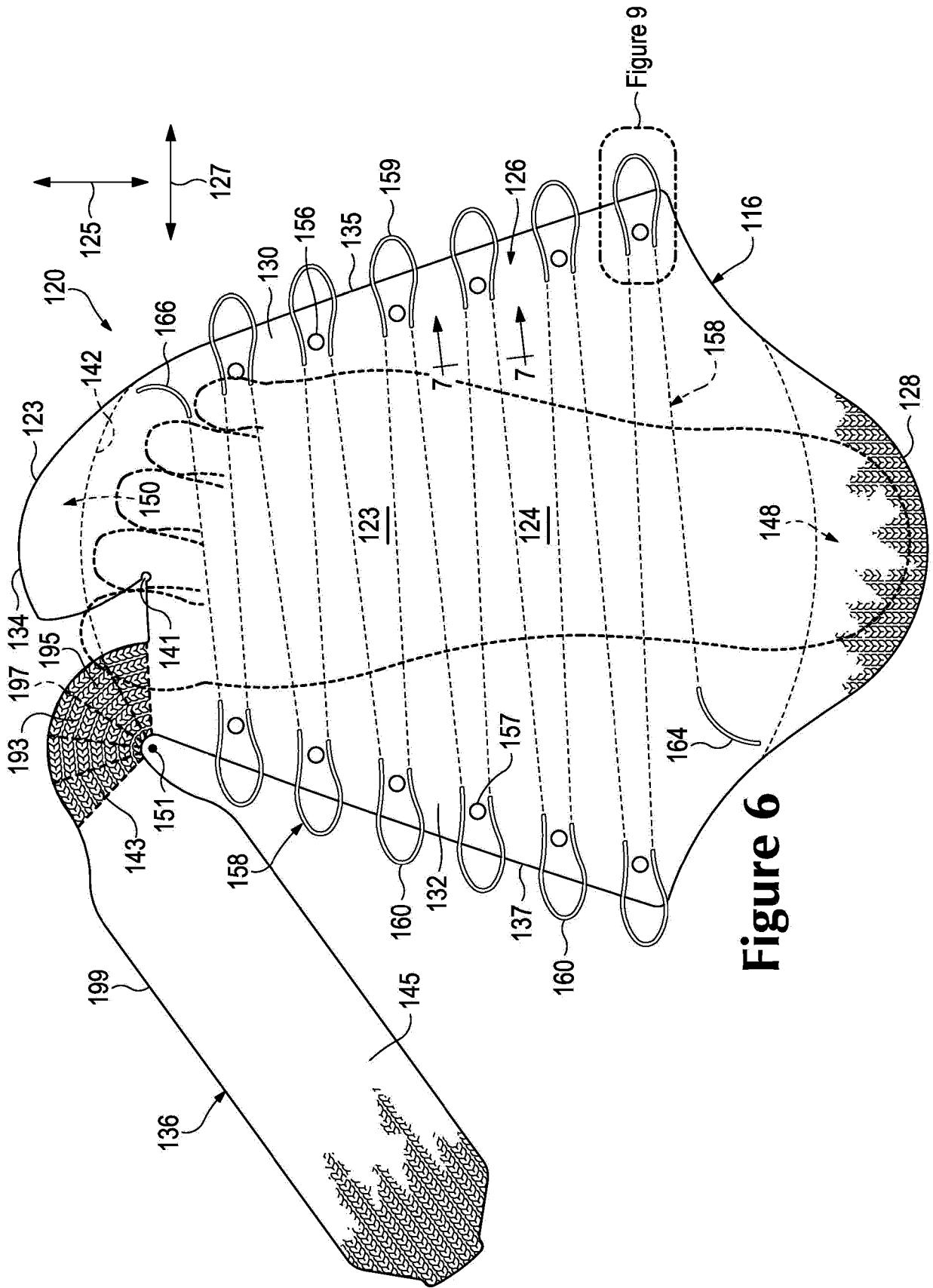

**Figure 6**

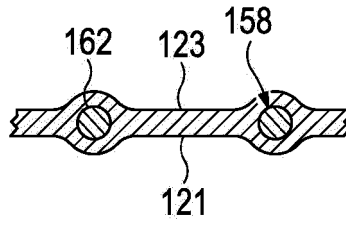

**Figure 7**

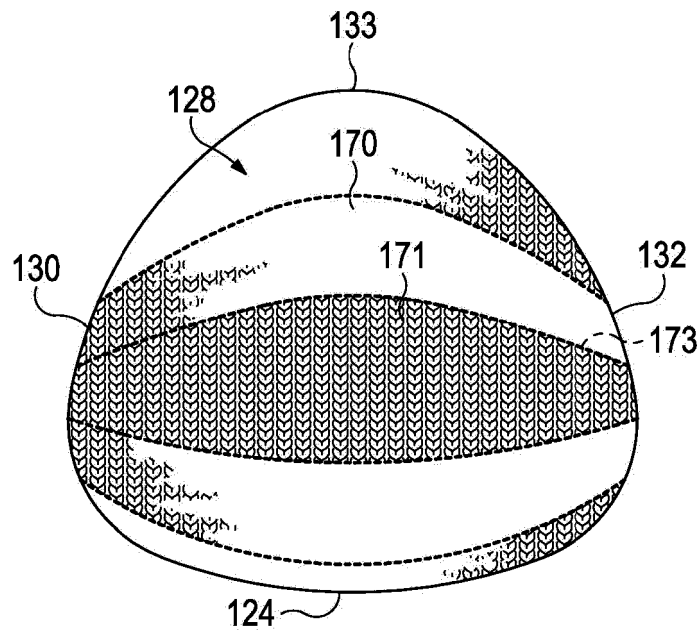

**Figure 8**

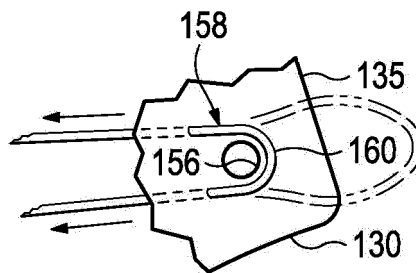

**Figure 9**

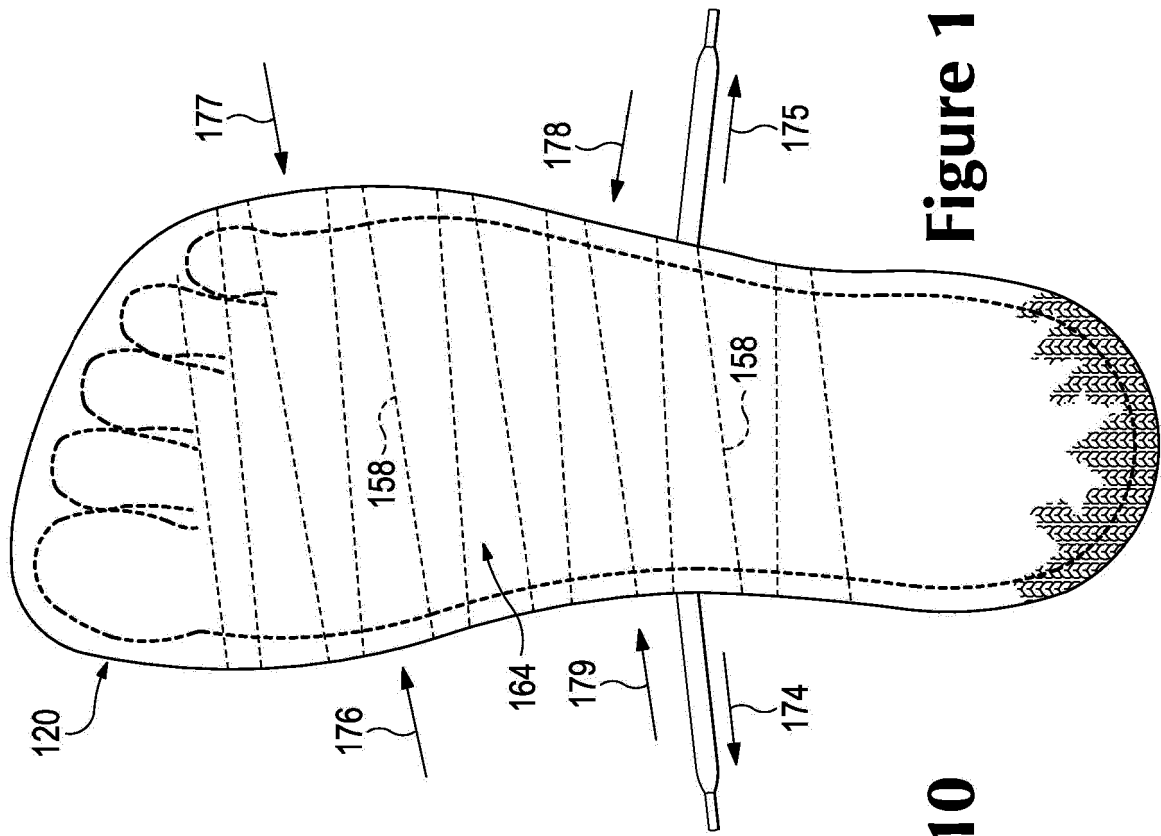

Figure 11

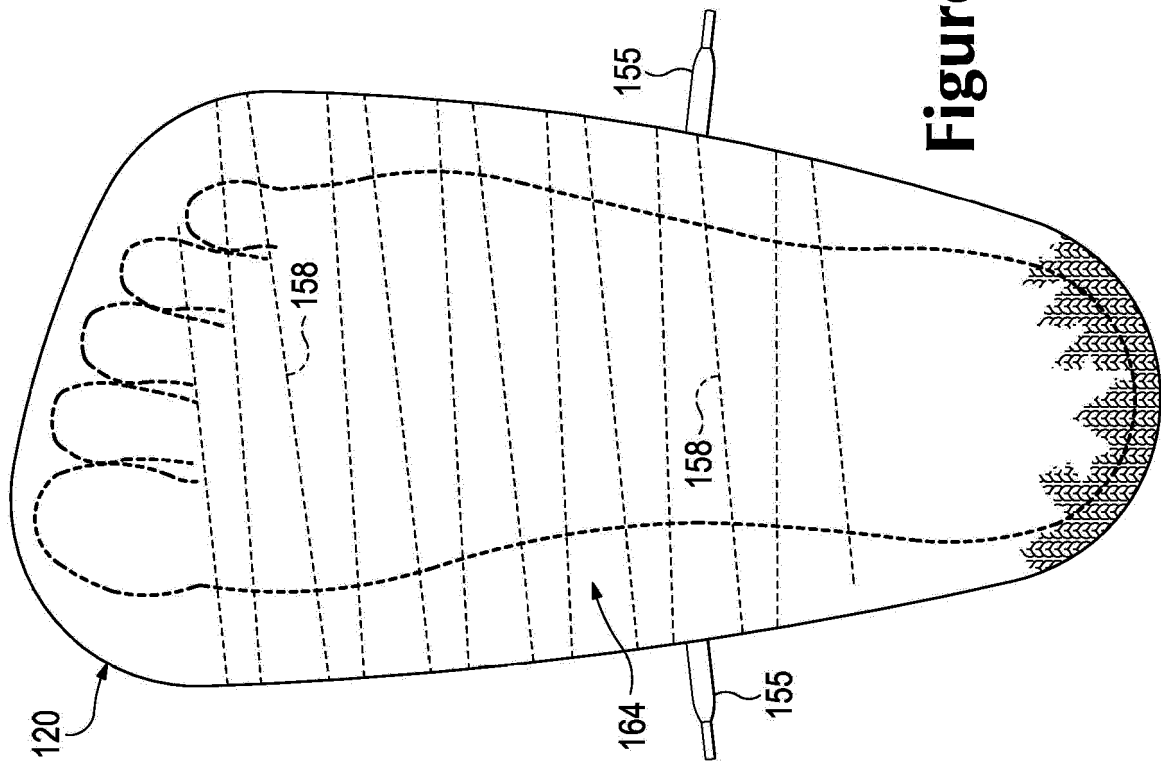
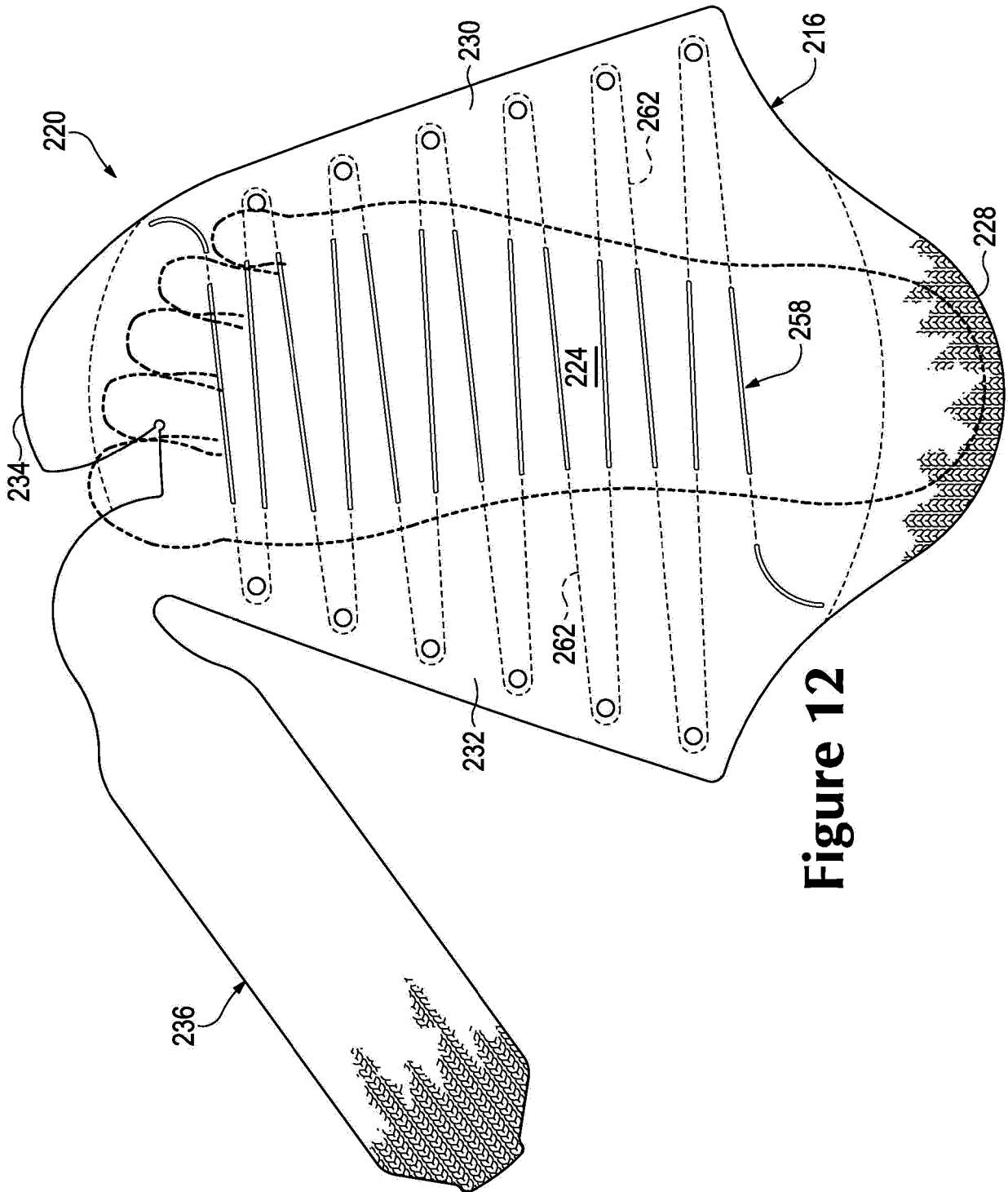
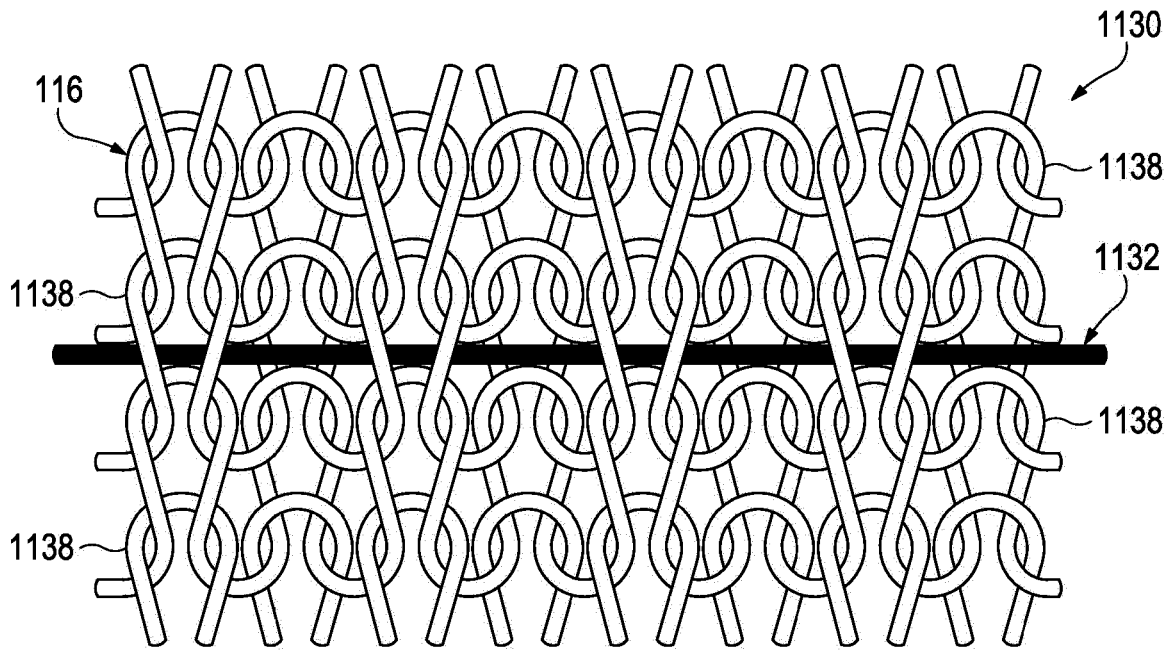

Figure 10



**Figure 12**



**Figure 13**

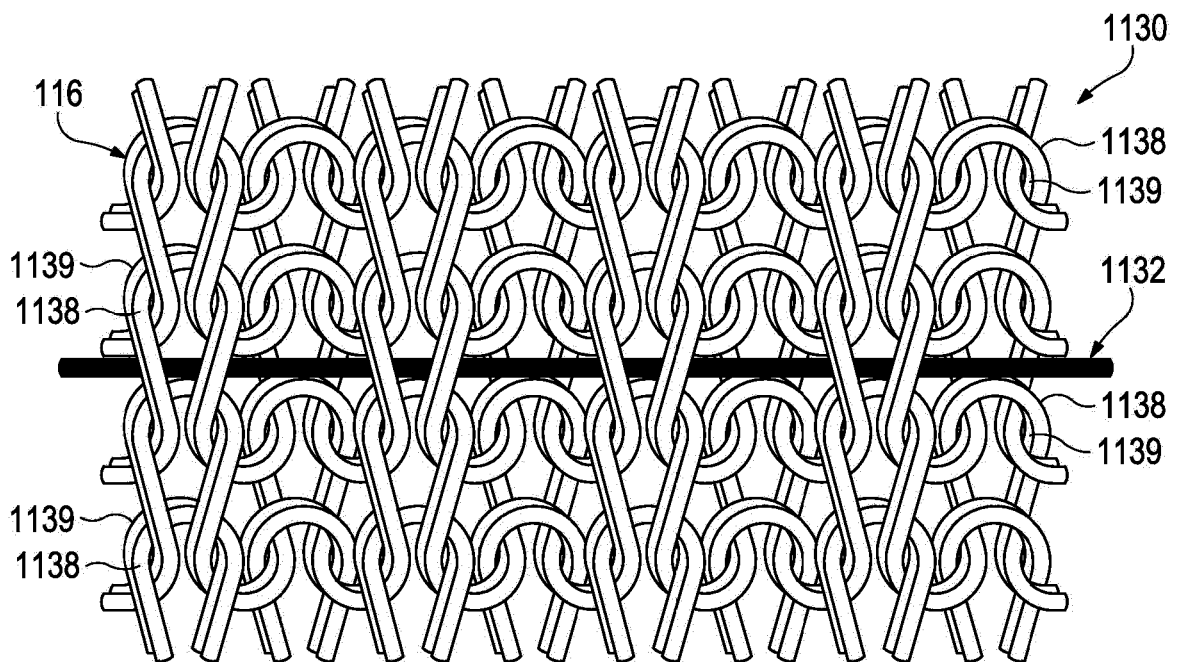

**Figure 14**

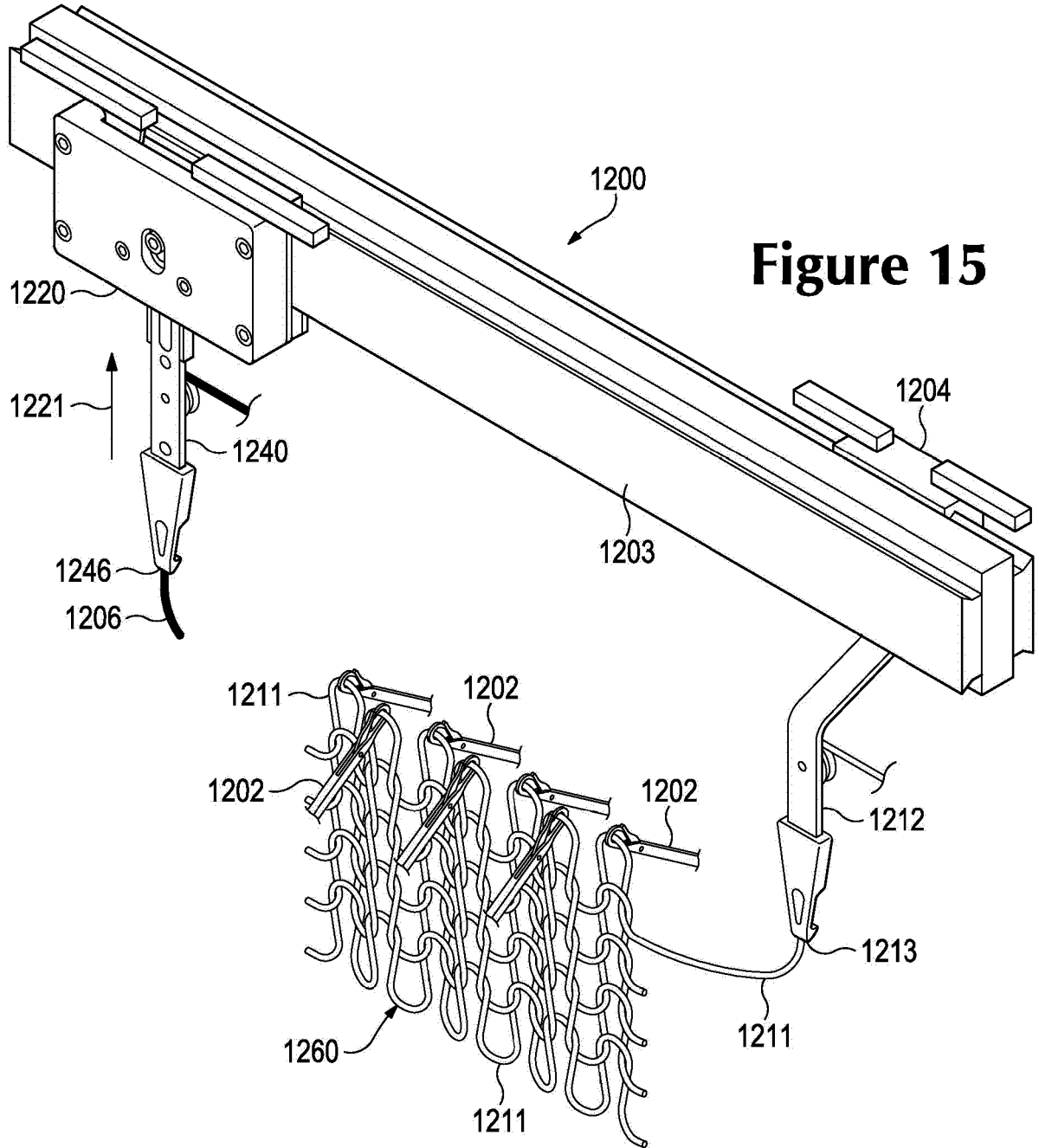
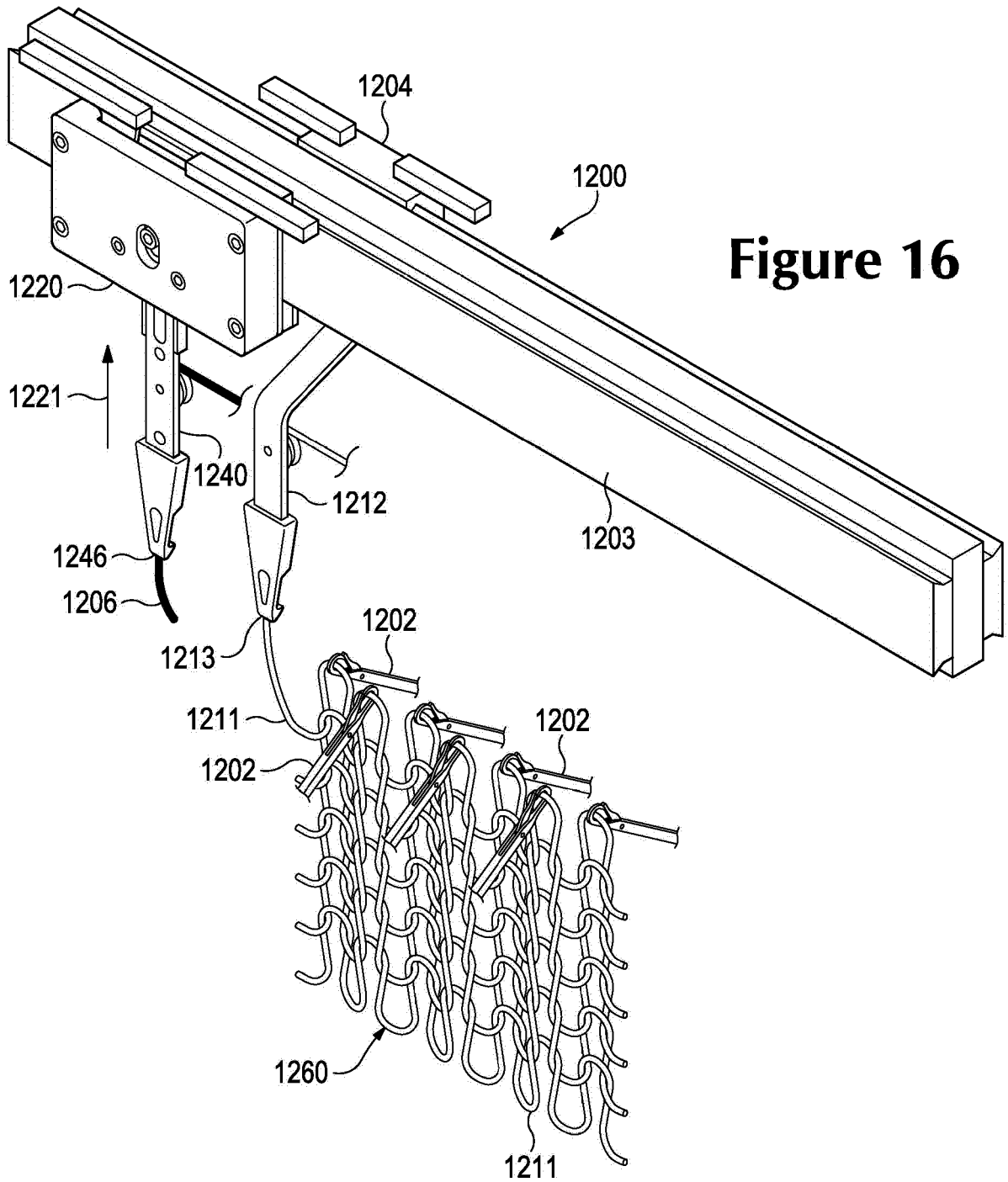
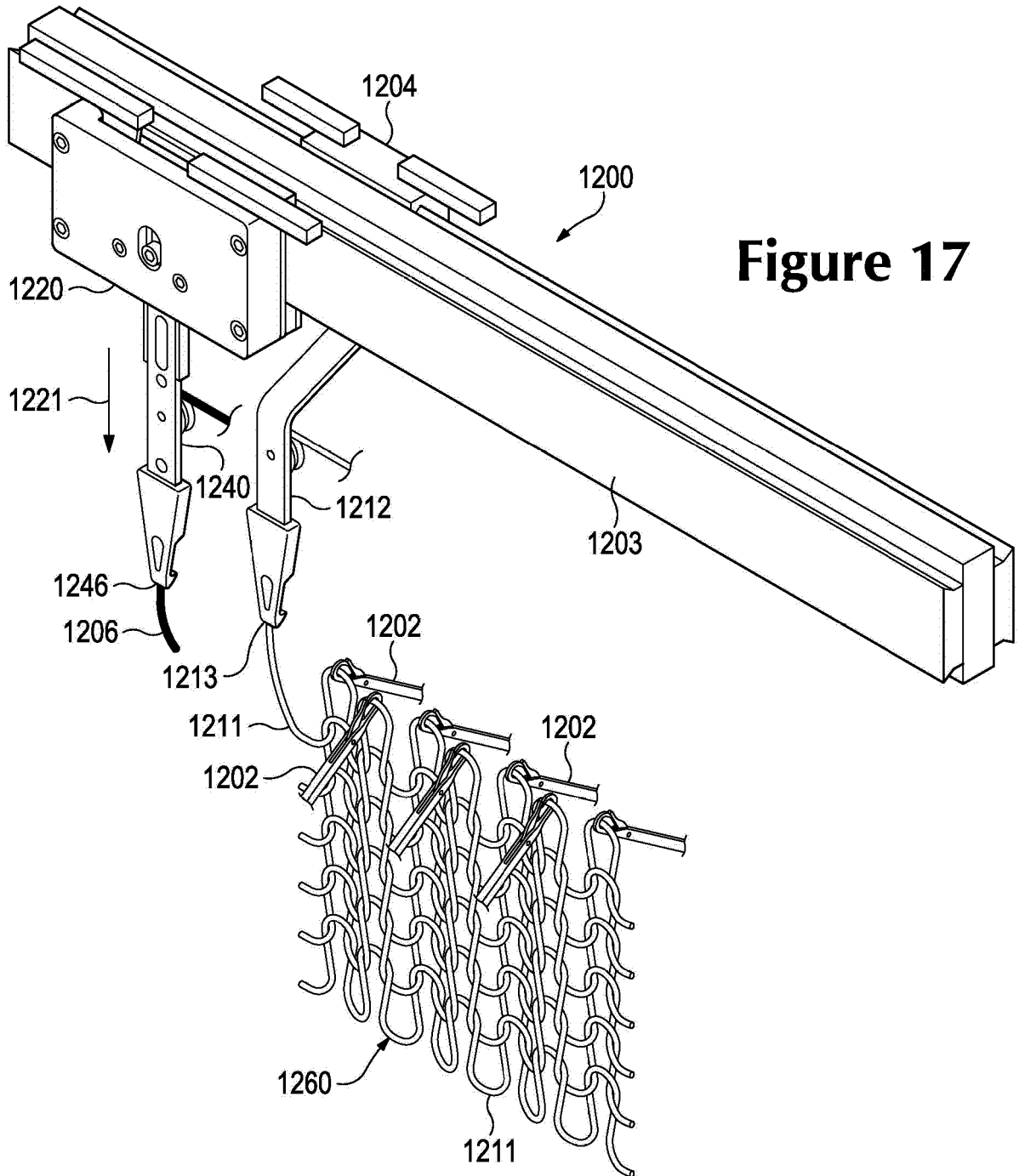
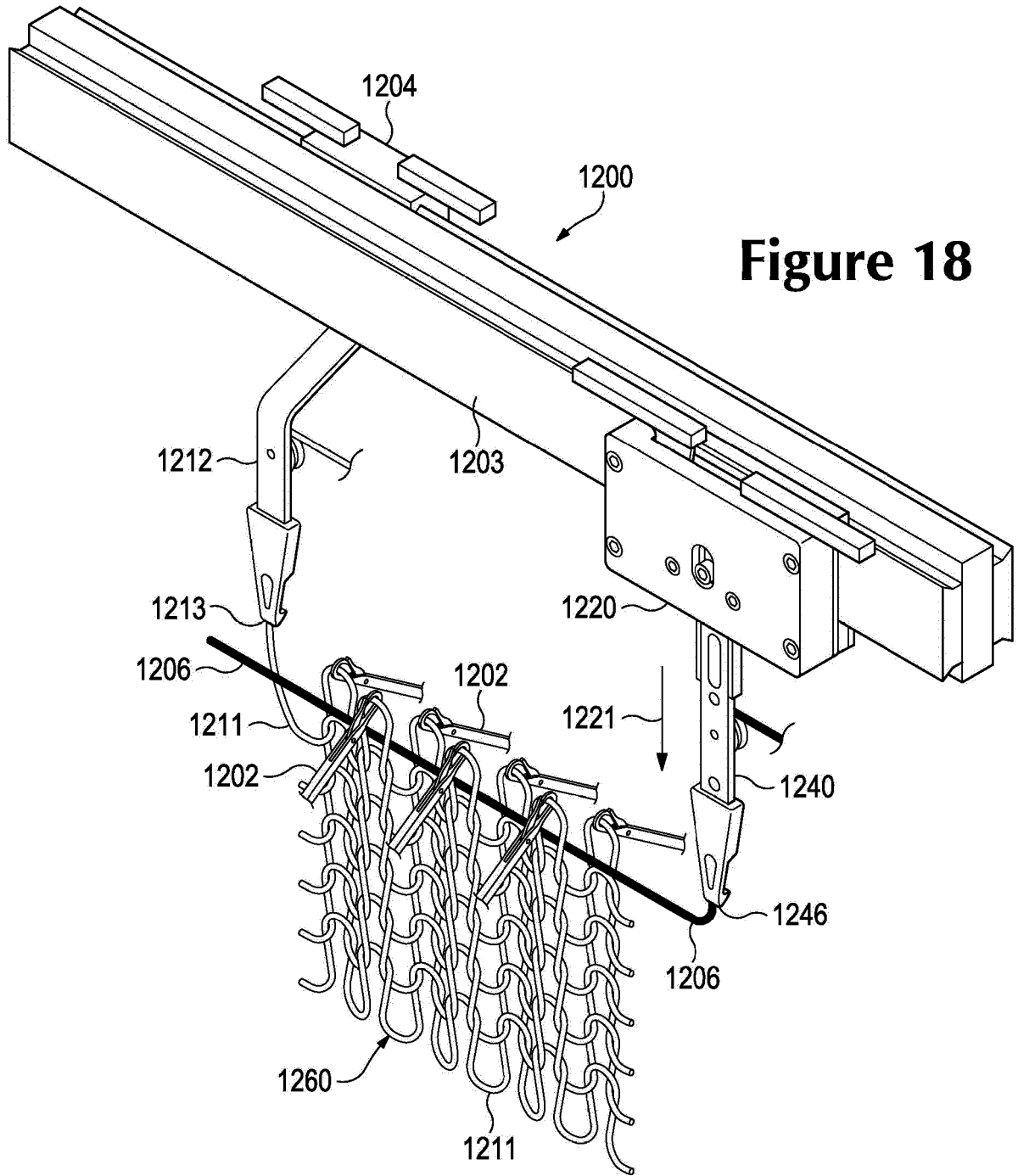
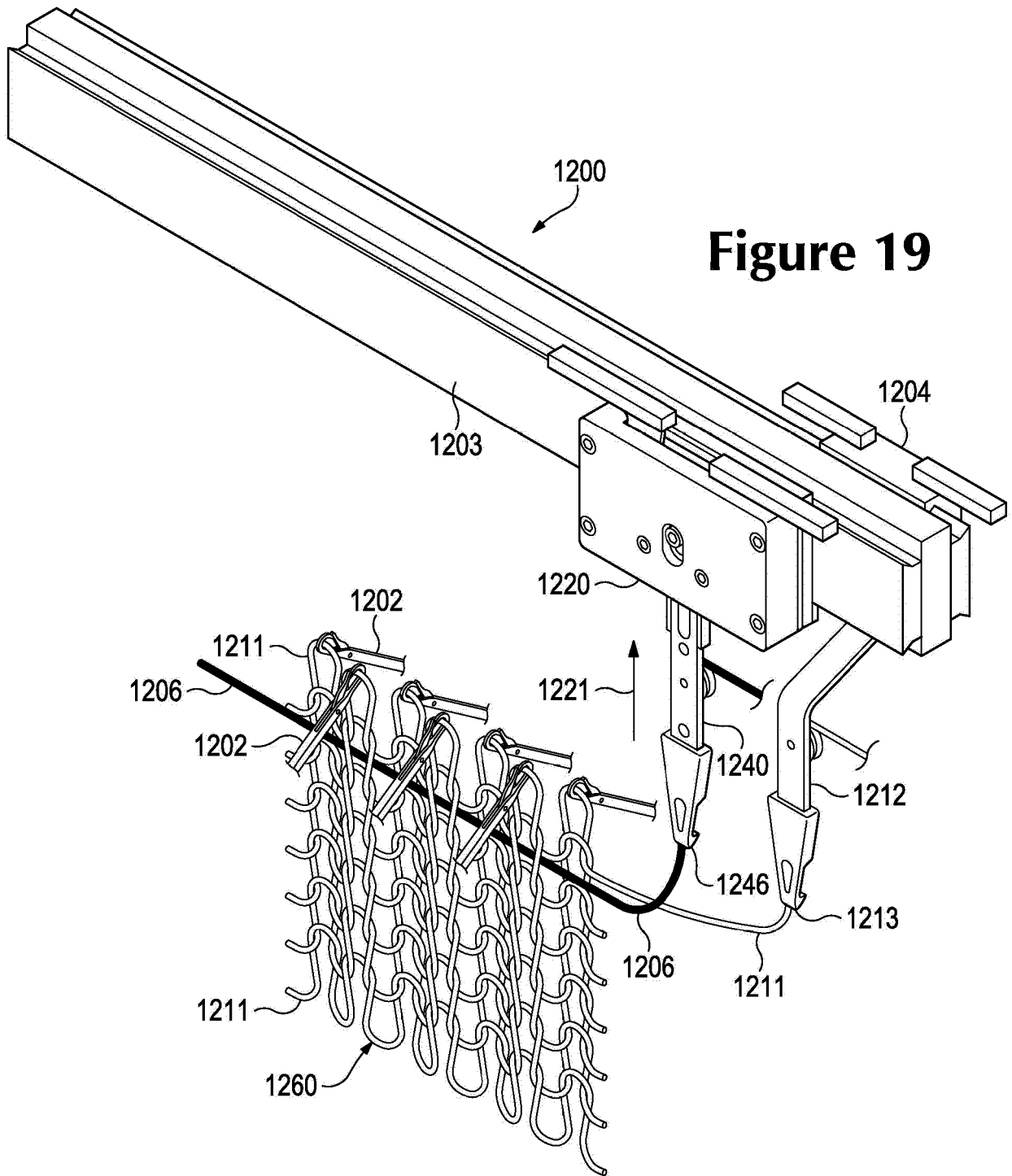

Figure 15









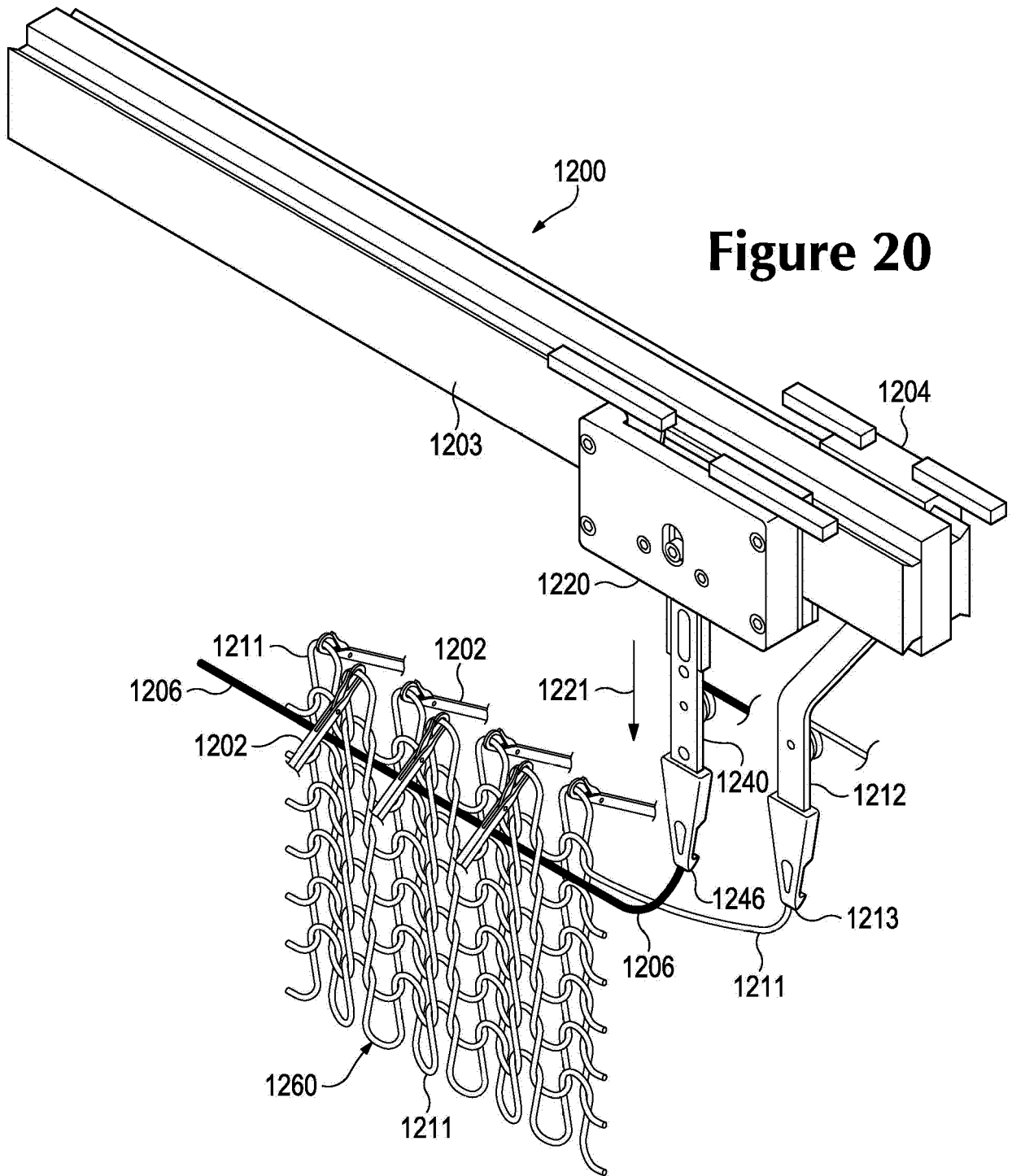

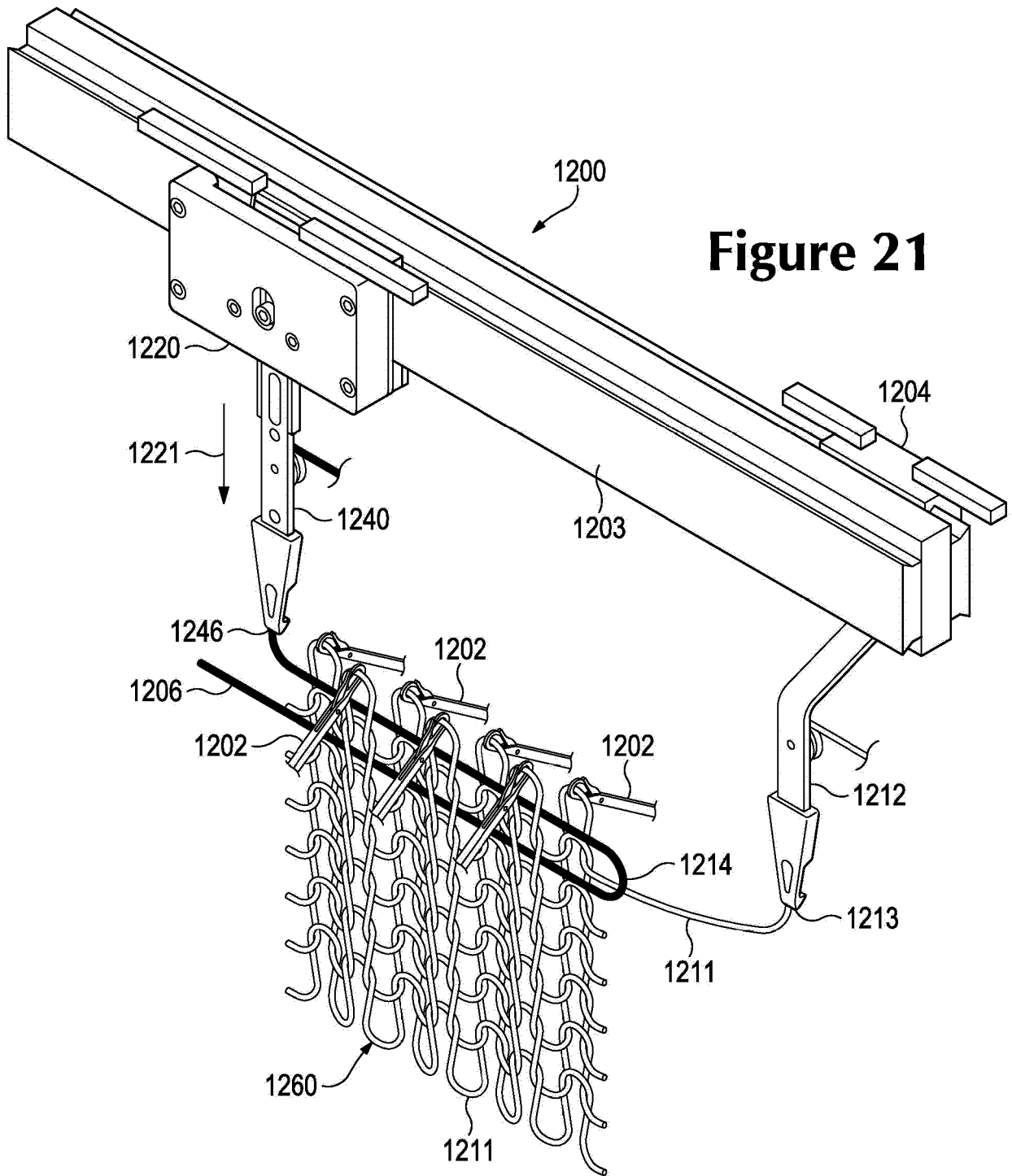

Figure 21

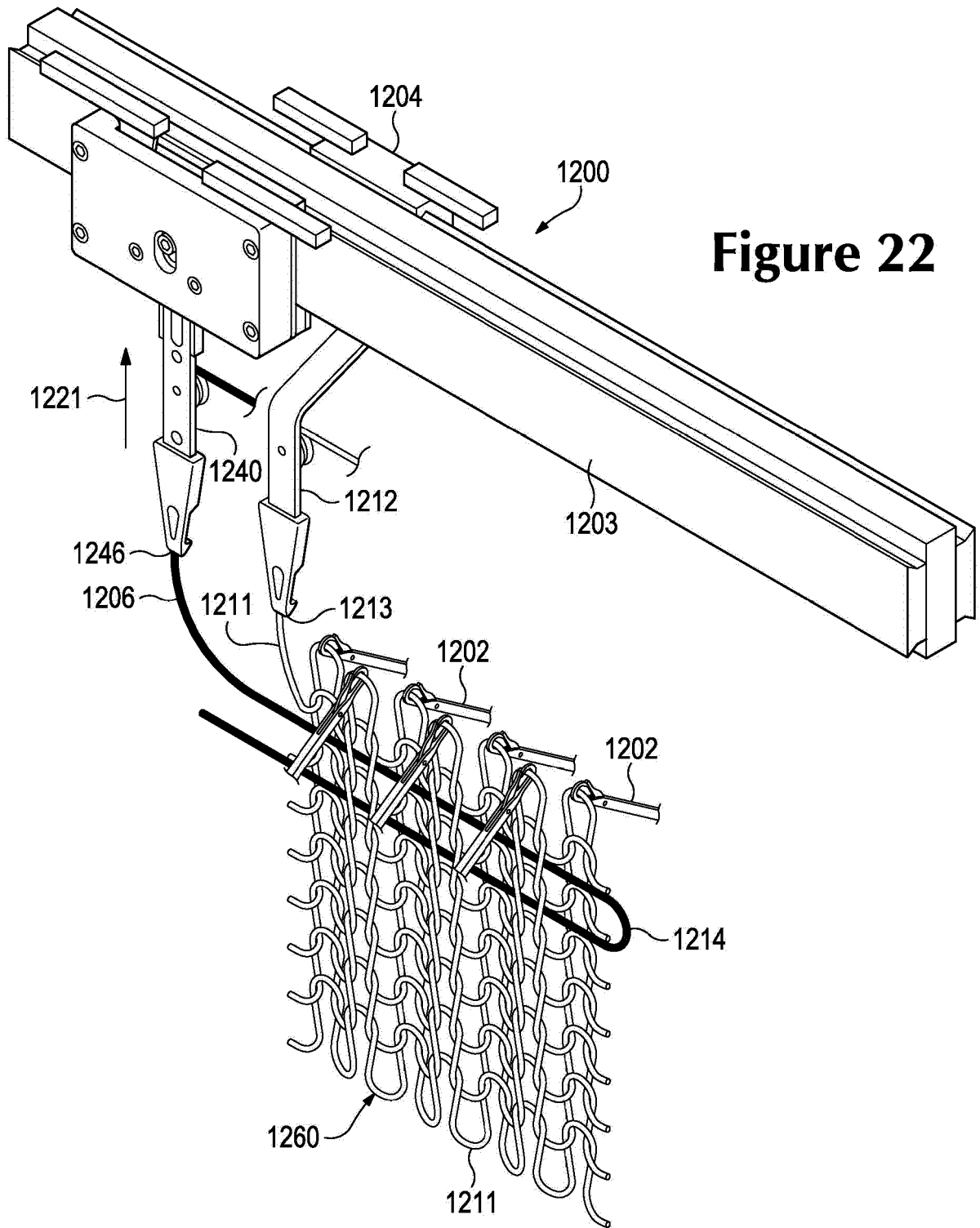

Figure 22

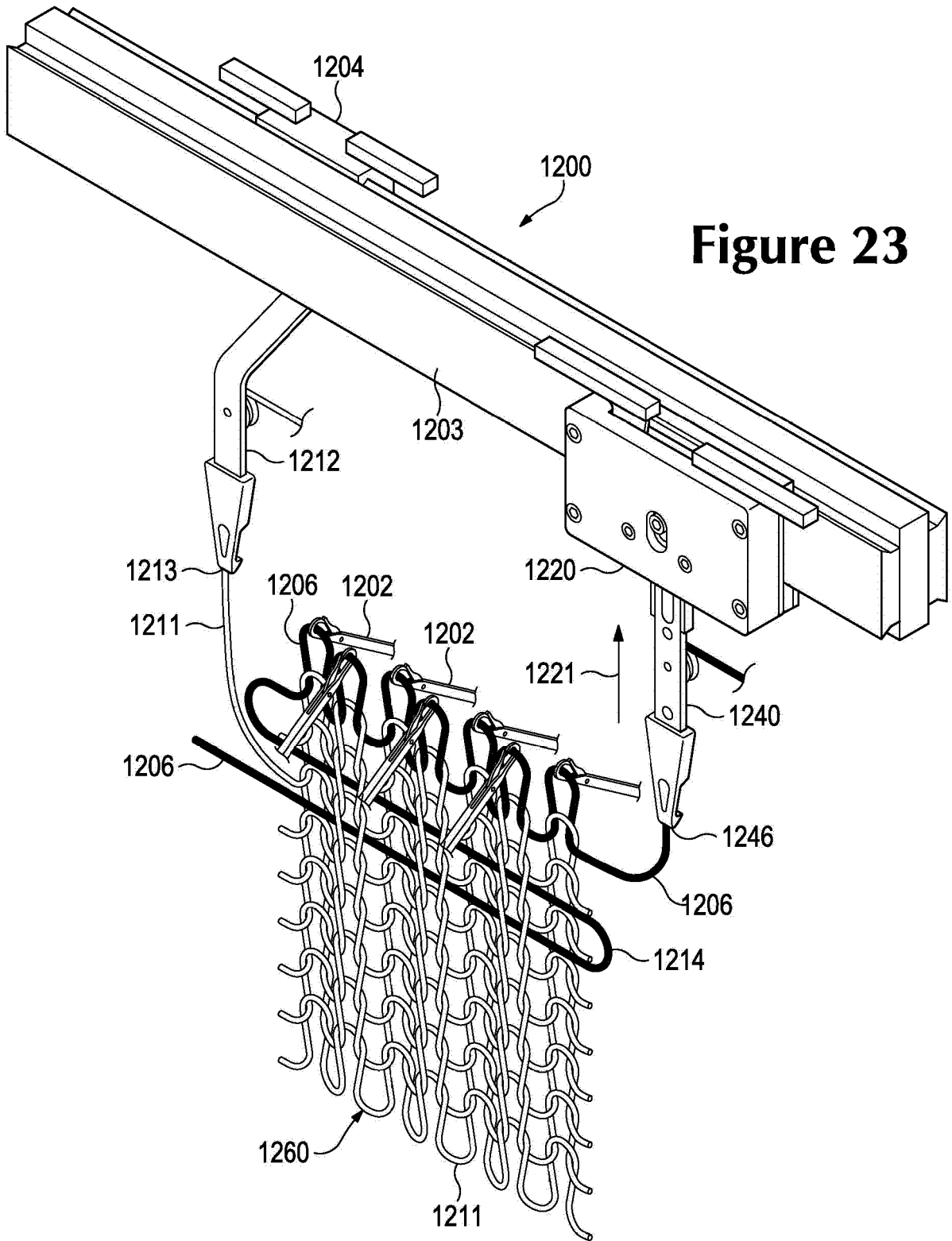
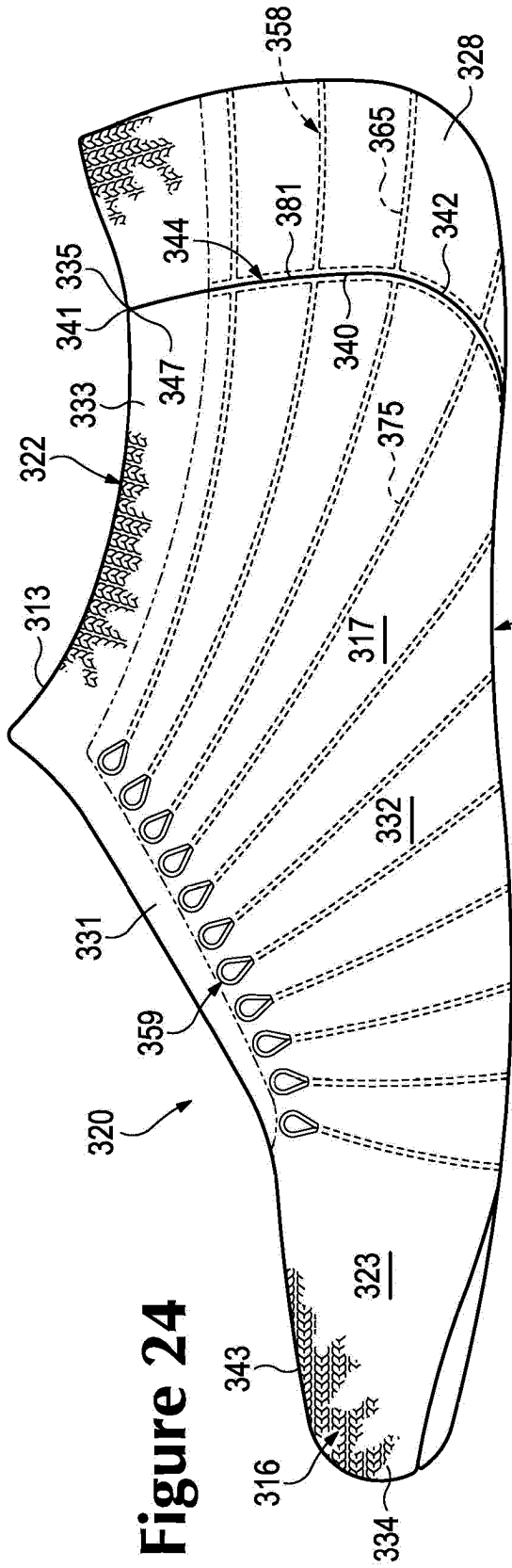
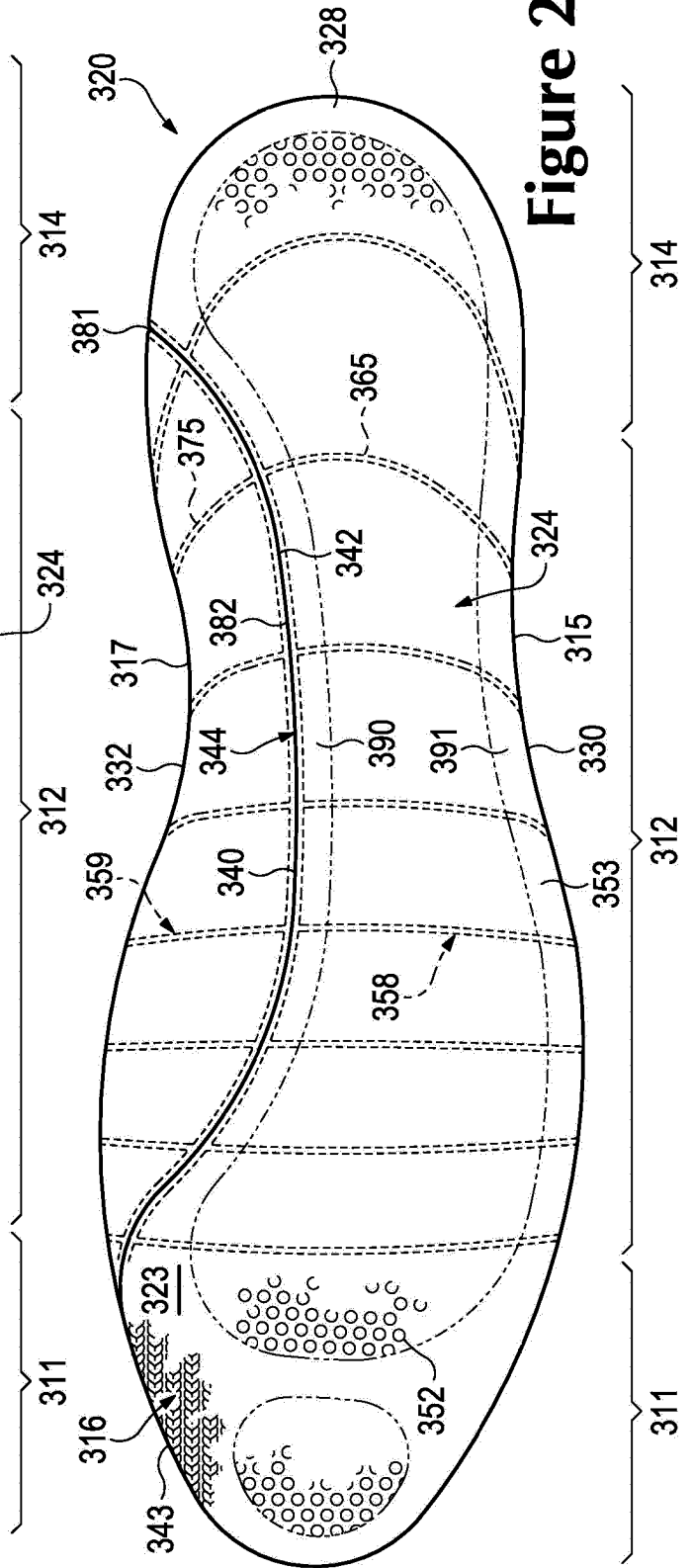

Figure 23

**Figure 24**



**Figure 25**



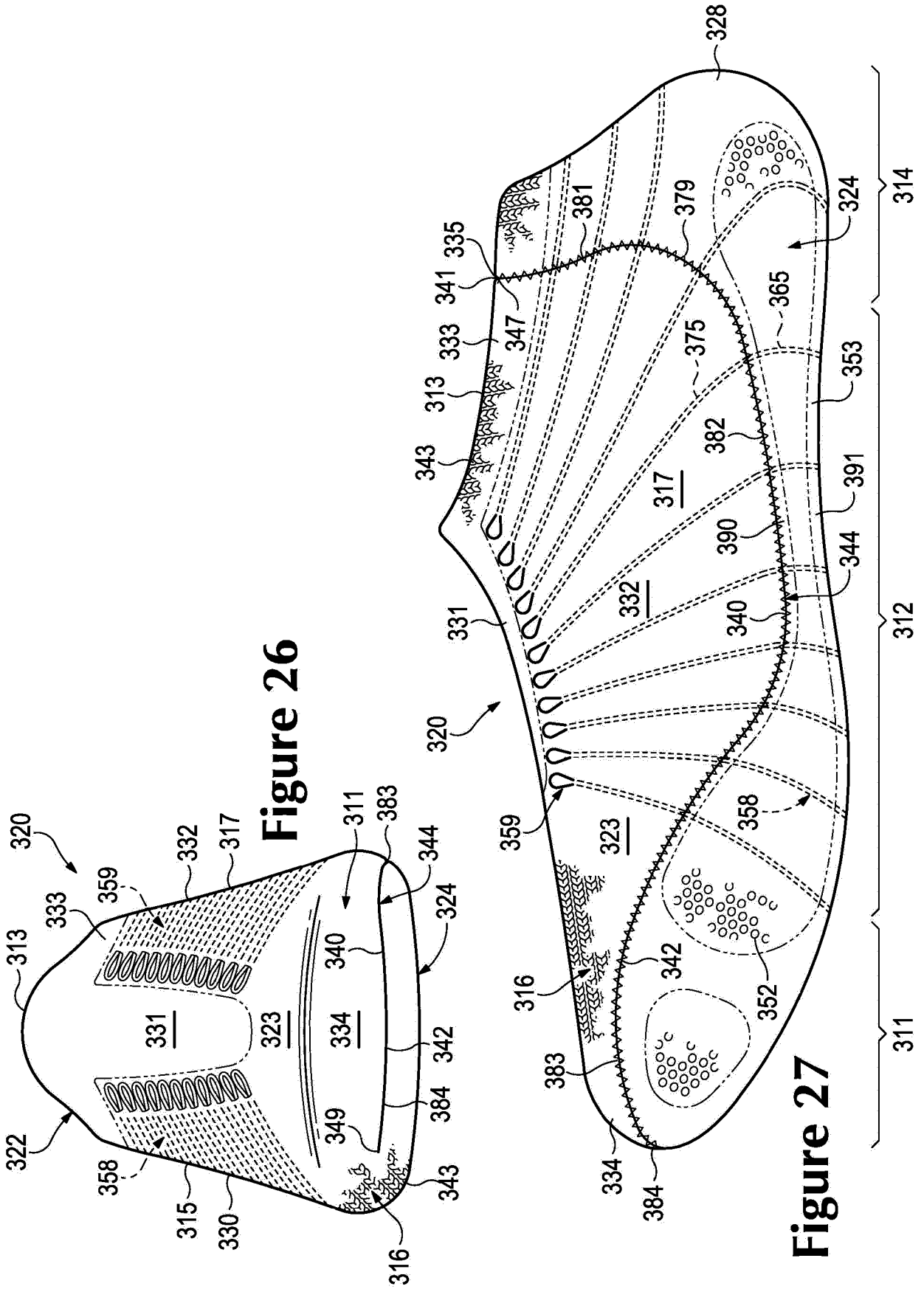

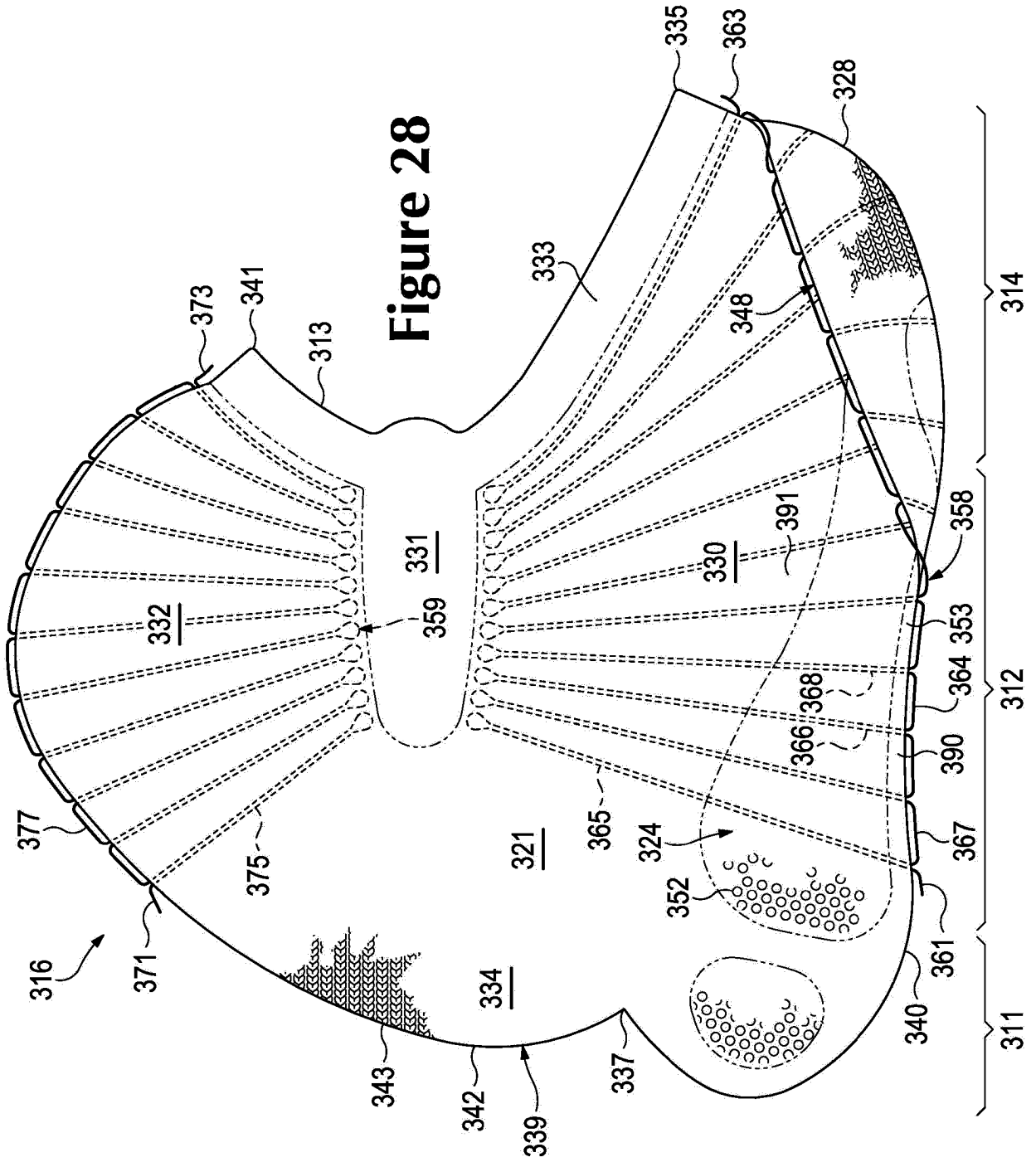

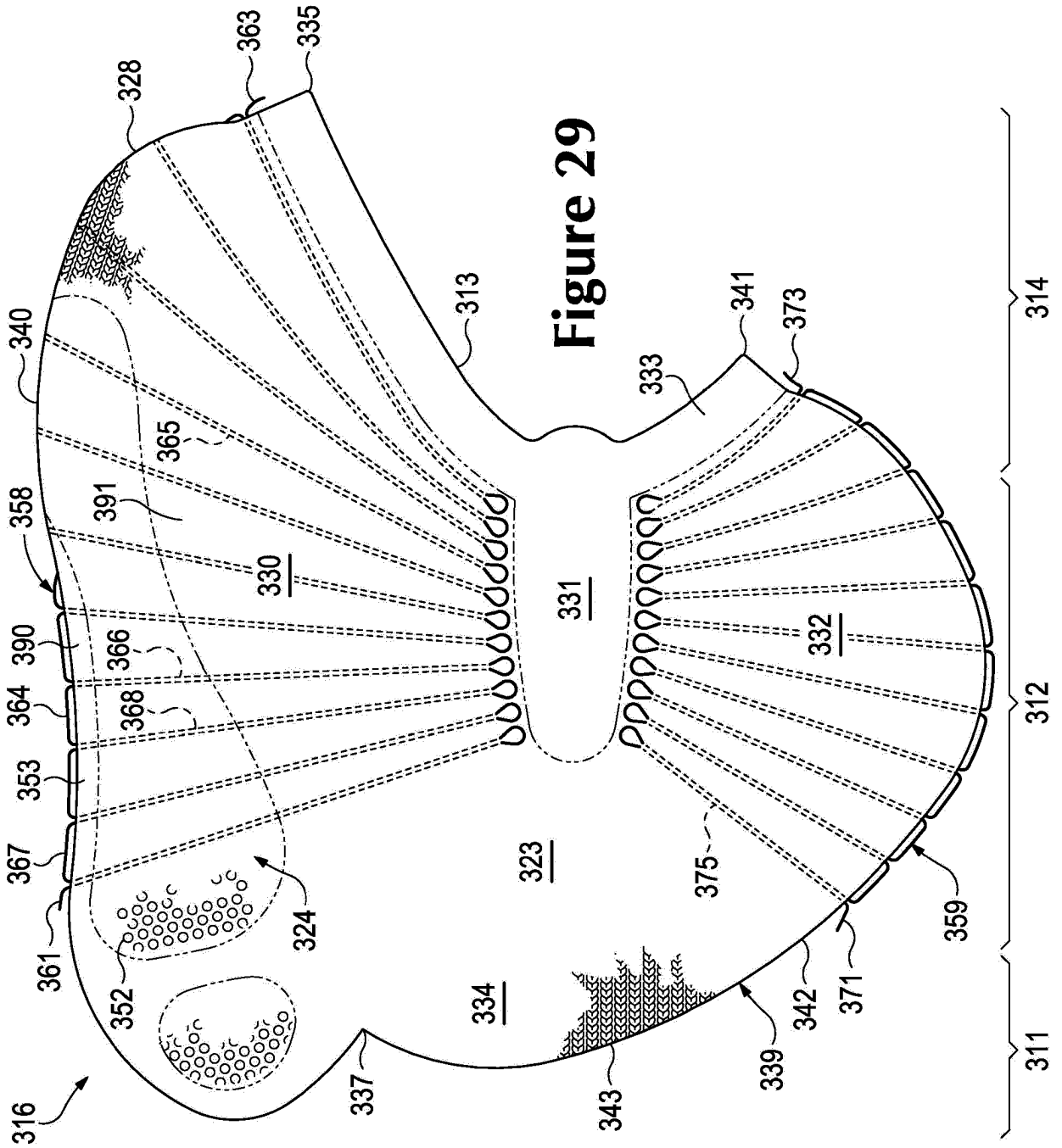

Figure 29



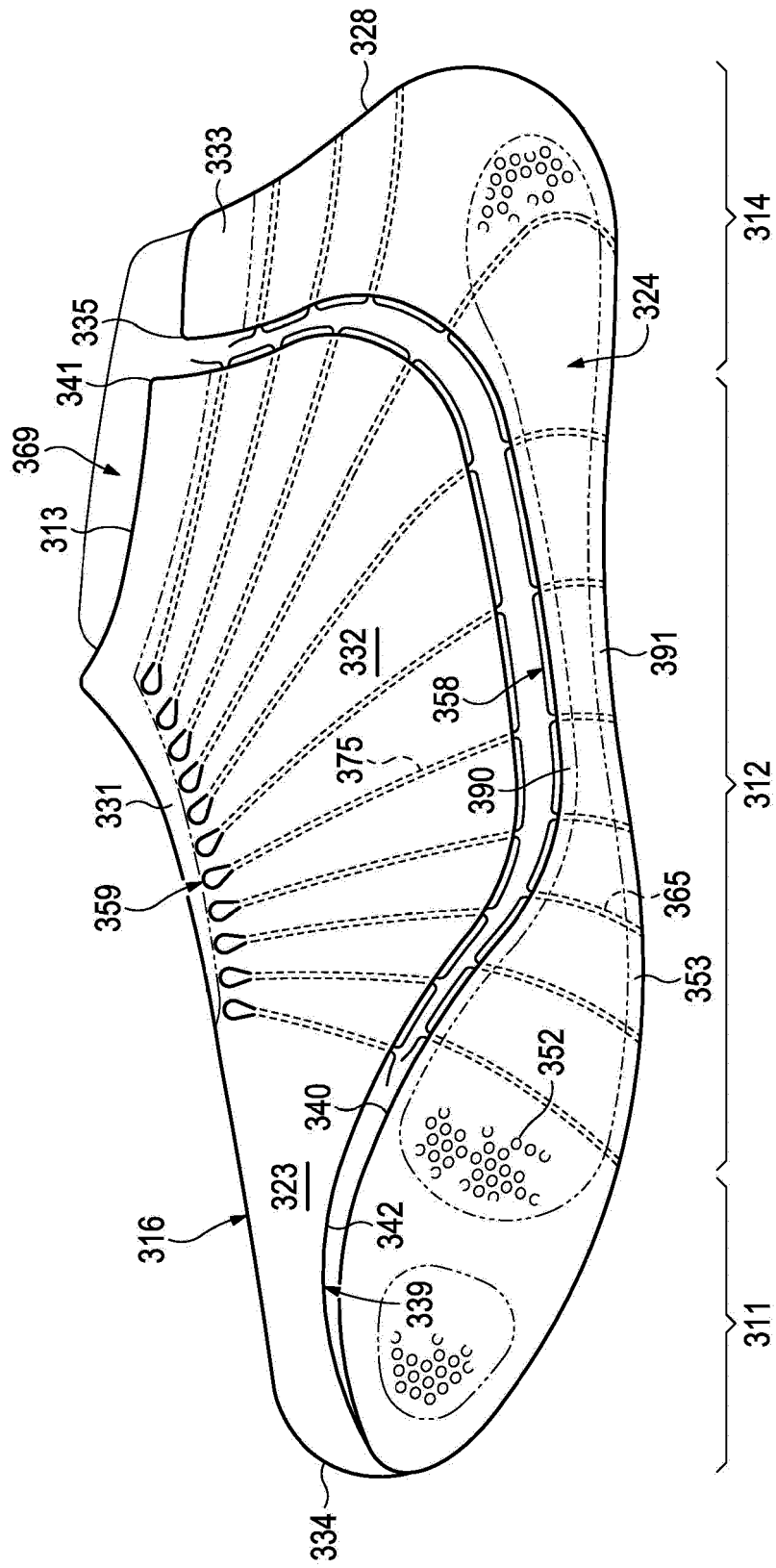

Figure 31

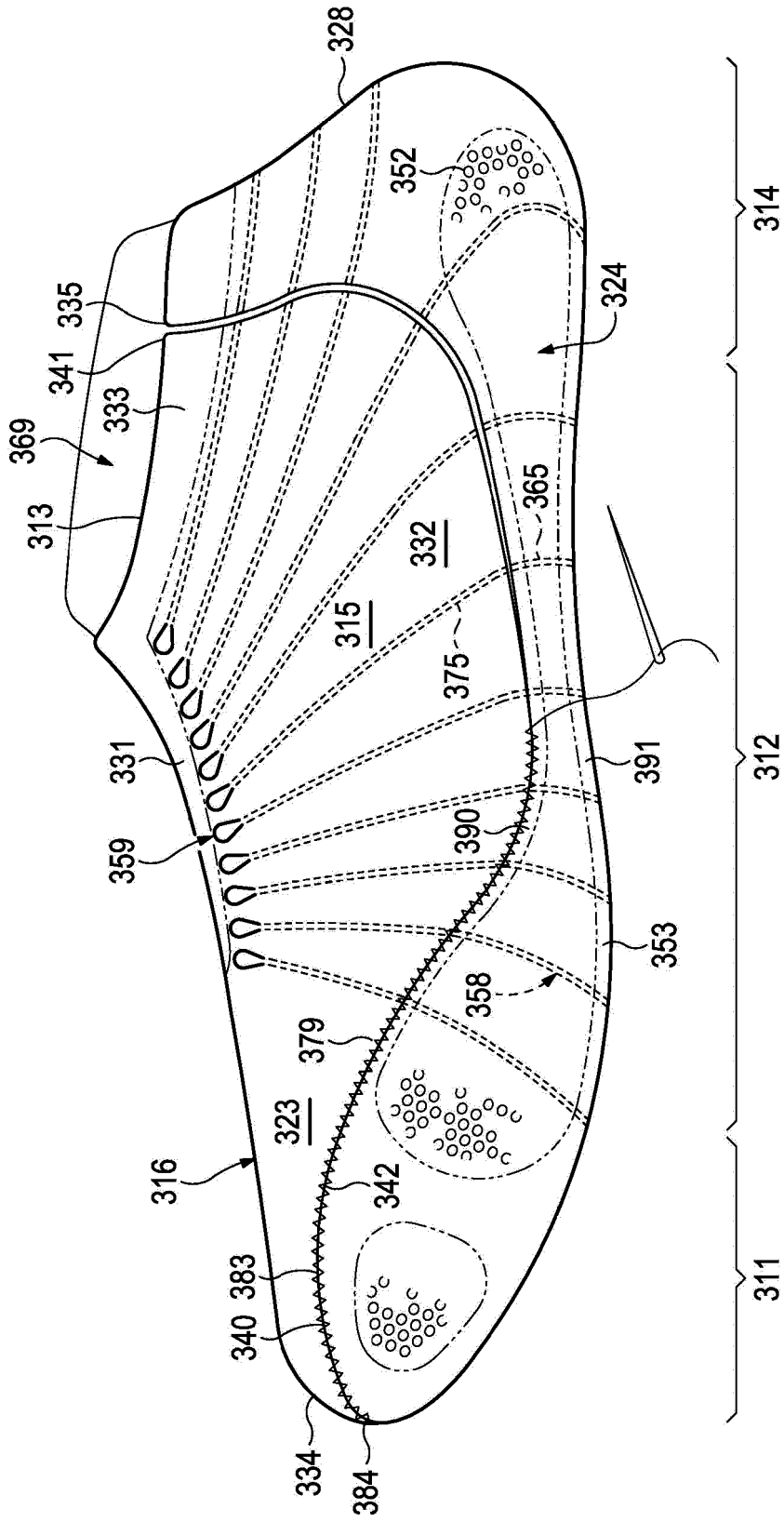

Figure 32

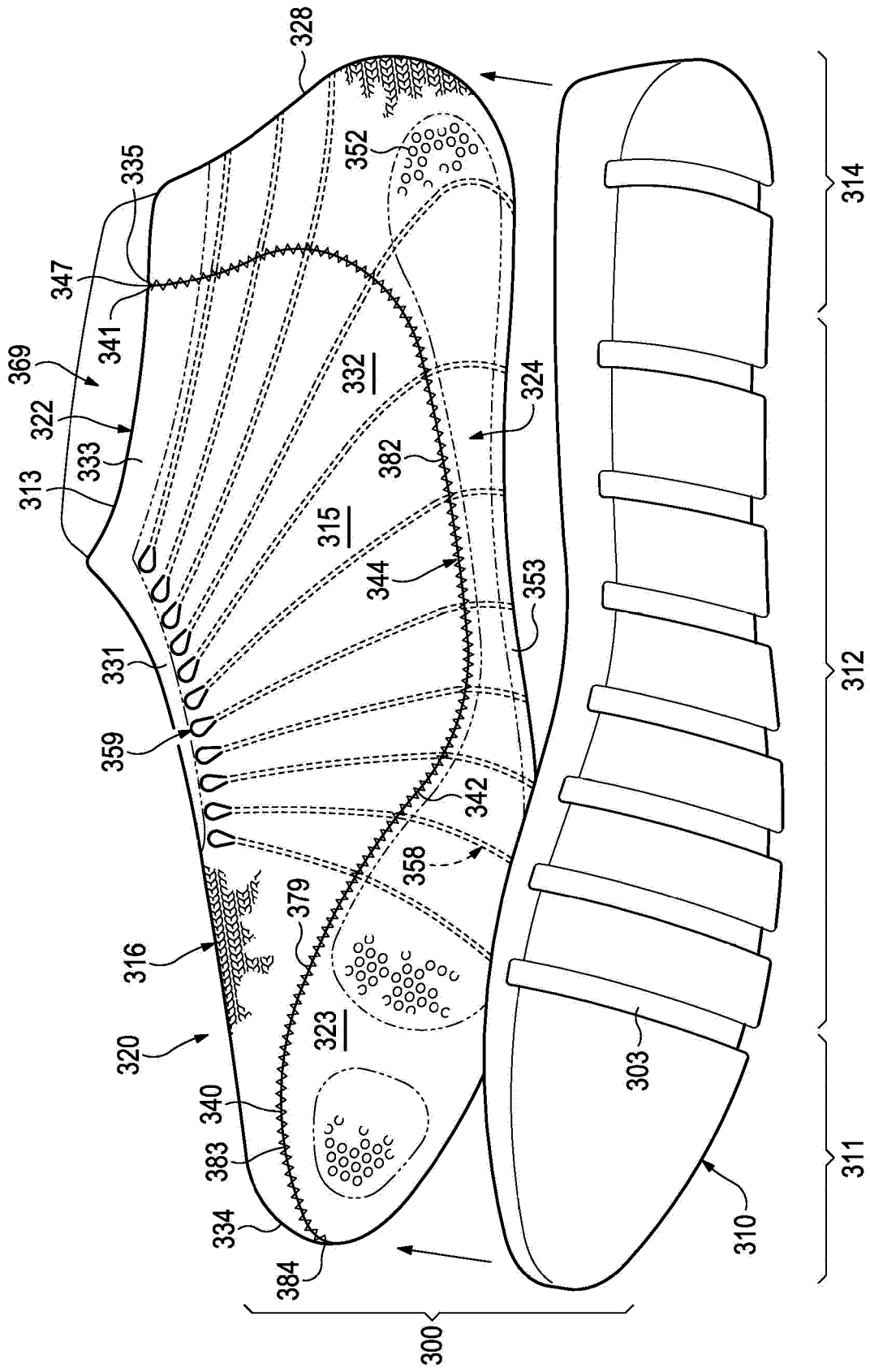

Figure 33

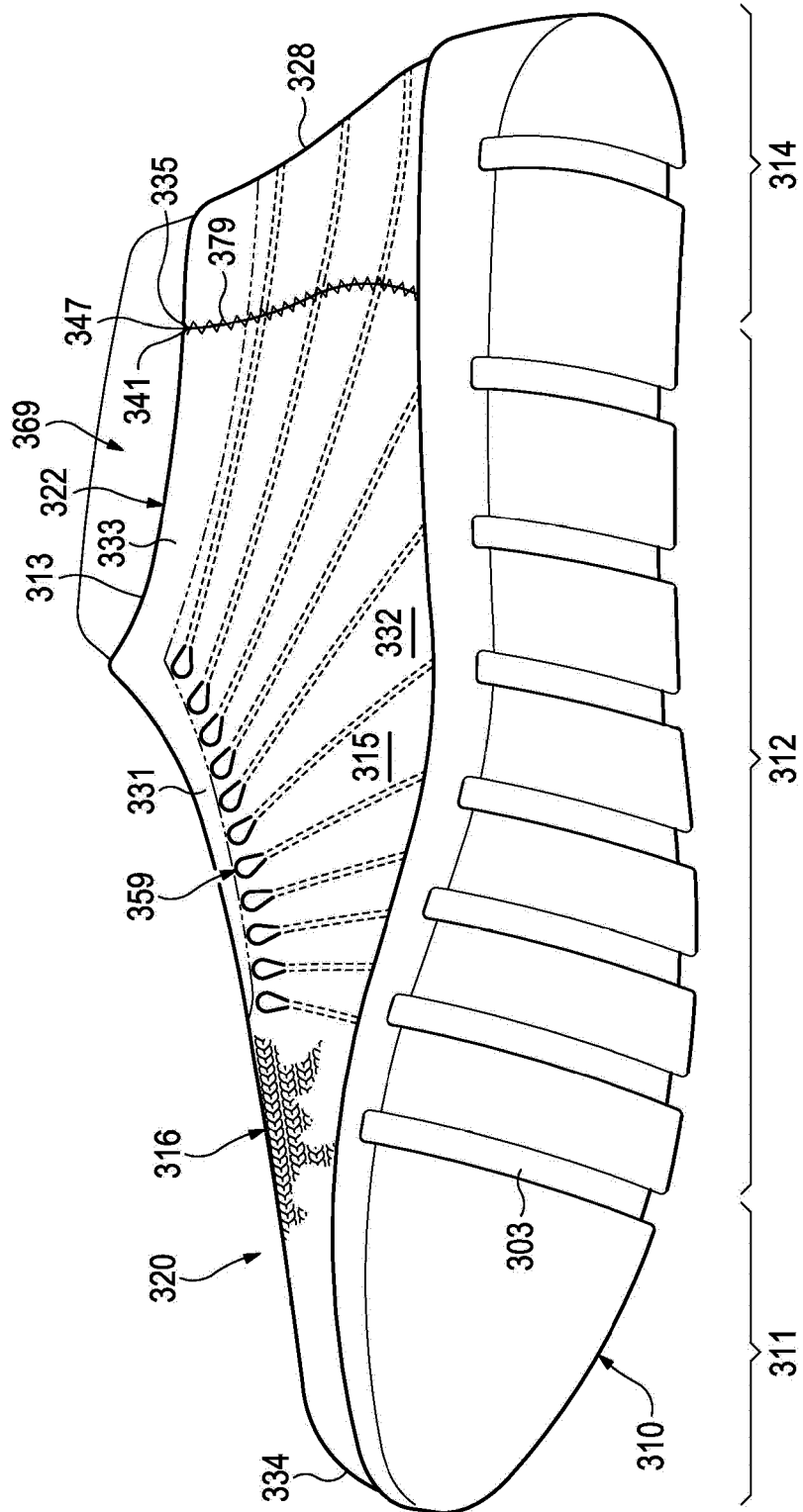
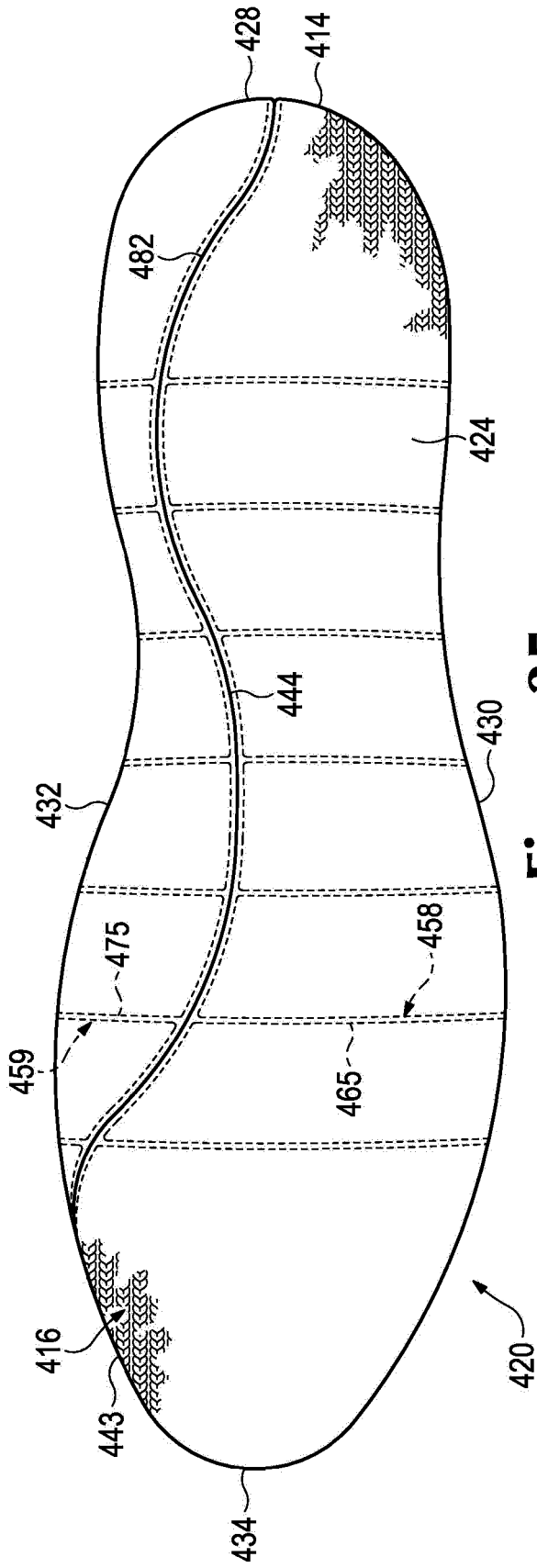
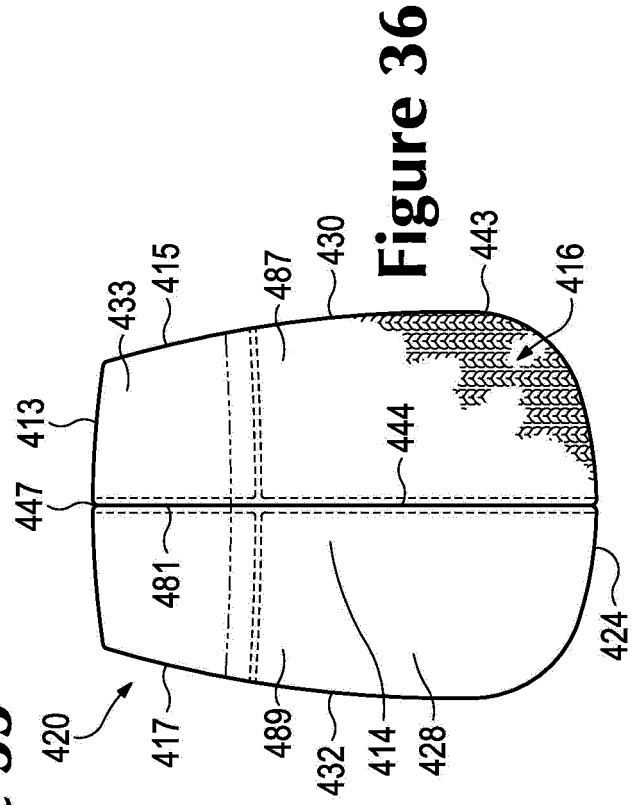

Figure 34



**Figure 35**



**Figure 36**

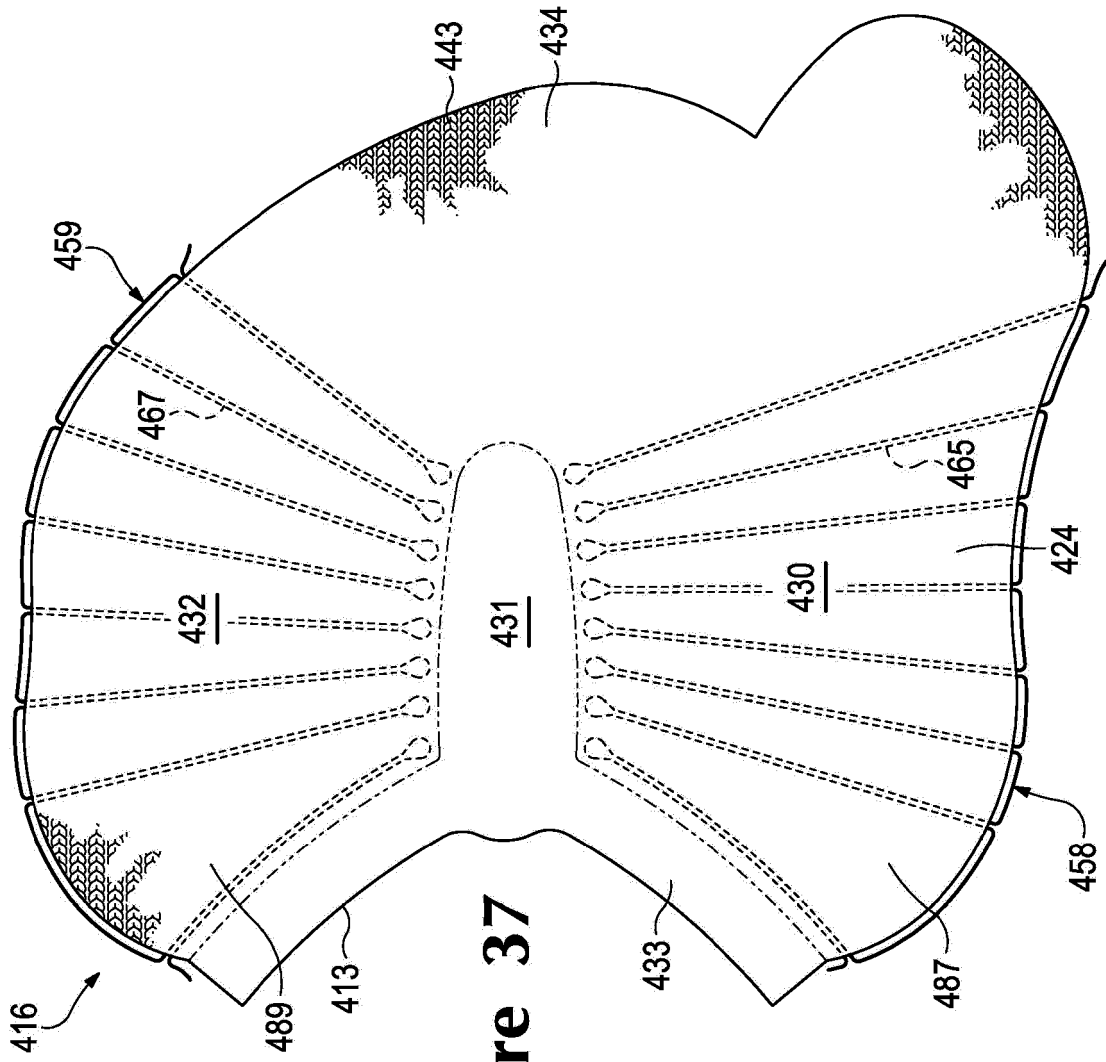

Figure 37

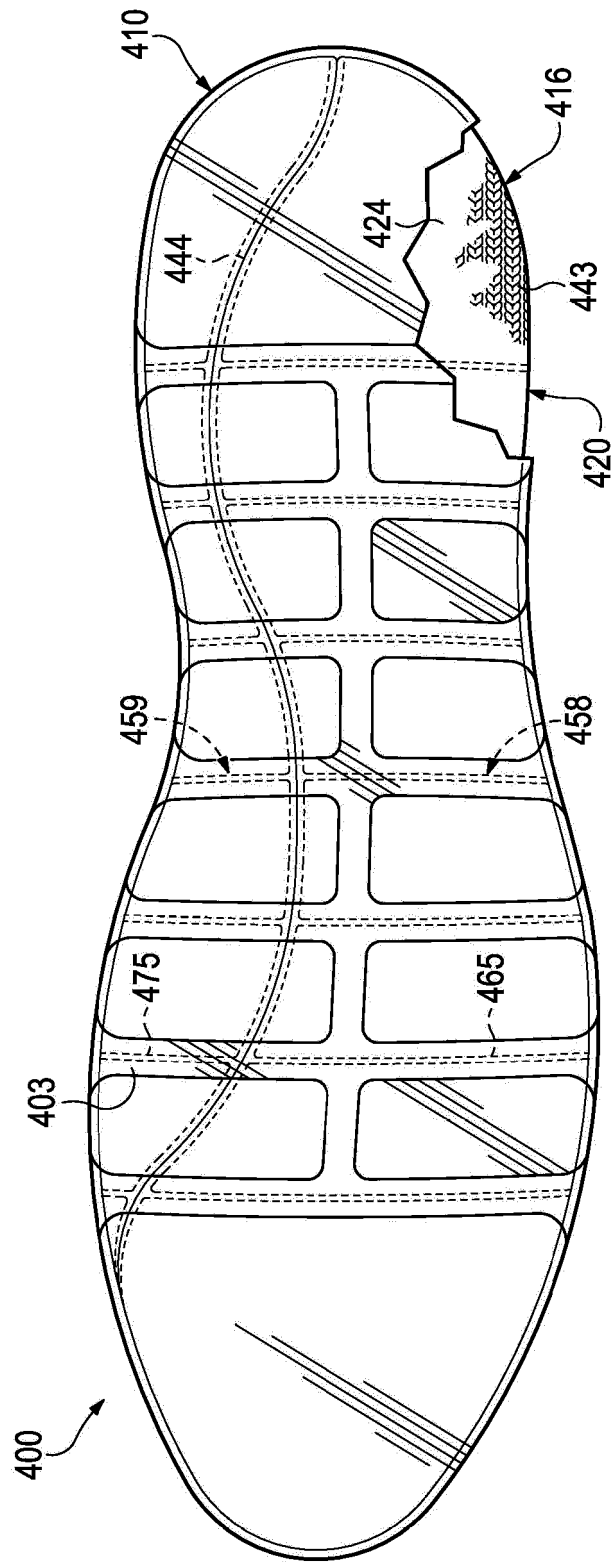

Figure 38

**REFERENCES CITED IN THE DESCRIPTION**

*This list of references cited by the applicant is for the reader's convenience only. It does not form part of the European patent document. Even though great care has been taken in compiling the references, errors or omissions cannot be excluded and the EPO disclaims all liability in this regard.*

**Patent documents cited in the description**

- US 5345638 A [0006]
- US 20120233882 A [0038] [0065] [0084]
- US 33872608, Dua [0061]
- US 20100154256 [0061]
- US 04851411, Huffa [0061]
- US 20120233882 [0061]